

Model 485 Autoranging Picoammeter

Instruction Manual



Contains Operating and Servicing Information



WARRANTY

Keithley Instruments, Inc. warrants this product to be free from defects in material and workmanship for a period of 1 year from date of shipment.

Keithley Instruments, Inc. warrants the following items for 90 days from the date of shipment: probes, cables, rechargeable batteries, diskettes, and documentation.

During the warranty period, we will, at our option, either repair or replace any product that proves to be defective.

To exercise this warranty, write or call your local Keithley representative, or contact Keithley headquarters in Cleveland, Ohio. You will be given prompt assistance and return instructions. Send the product, transportation prepaid, to the indicated service facility. Repairs will be made and the product returned, transportation prepaid. Repaired or replaced products are warranted for the balance of the original warranty period, or at least 90 days.

LIMITATION OF WARRANTY

This warranty does not apply to defects resulting from product modification without Keithley's express written consent, or misuse of any product or part. This warranty also does not apply to fuses, software, non-rechargeable batteries, damage from battery leakage, or problems arising from normal wear or failure to follow instructions.

THIS WARRANTY IS IN LIEU OF ALL OTHER WARRANTIES, EXPRESSED OR IMPLIED, INCLUDING ANY IMPLIED WARRANTY OF MERCHANTABILITY OR FITNESS FOR A PARTICULAR USE. THE REMEDIES PROVIDED HEREIN ARE BUYER'S SOLE AND EXCLUSIVE REMEDIES.

NEITHER KEITHLEY INSTRUMENTS, INC. NOR ANY OF ITS EMPLOYEES SHALL BE LIABLE FOR ANY DIRECT, INDIRECT, SPECIAL, INCIDENTAL OR CONSEQUENTIAL DAMAGES ARISING OUT OF THE USE OF ITS INSTRUMENTS AND SOFTWARE EVEN IF KEITHLEY INSTRUMENTS, INC., HAS BEEN ADVISED IN ADVANCE OF THE POSSIBILITY OF SUCH DAMAGES. SUCH EXCLUDED DAMAGES SHALL INCLUDE, BUT ARE NOT LIMITED TO: COSTS OF REMOVAL AND INSTALLATION, LOSSES SUSTAINED AS THE RESULT OF INJURY TO ANY PERSON, OR DAMAGE TO PROPERTY.

KEITHLEY

Keithley Instruments, Inc. • 28775 Aurora Road • Cleveland, OH 44139 • 216-248-0400 • Fax: 216-248-6168 • <http://www.keithley.com>

CHINA:	Keithley Instruments China • Yuan Chen Xin Building, Room 705 • No. 12 Yumin Road, Dewai, Madian • Beijing, China 100029 • 8610-2022886 • Fax: 8610-2022892
FRANCE:	Keithley Instruments SARM • BP 60 • 3 allée des Garays • 91122 Palaiseau Cédex • 31-6-0115155 • Fax: 31-6-0117726
GERMANY:	Keithley Instruments GmbH • Landsberger Straße 65 • 82110 Germering • 49-89-849307-0 • Fax: 49-89-84930759
GREAT BRITAIN:	Keithley Instruments, Ltd. • The Minster • 58 Portman Road • Reading, Berkshire RG30 1EA • 44-01734-575666 • Fax: 44-01734-596469
ITALY:	Keithley Instruments SRL • Viale S. Gimignano 38 • 20146 Milano • 39-2-48303008 • Fax: 39-2-48302274
JAPAN:	Keithley KK • Aibido Bldg. • 7-20-2 Nishishinjuku • Shinjuku-ku, Tokyo 160 • 81-3-5389-1964 • Fax: 81-3-5389-2068
NETHERLANDS:	Keithley Instruments BV • Avelingen West 49 • 4202 MS Gorinchem • 31-(0)183-635333 • Fax: 31-(0)183-630821
SWITZERLAND:	Keithley Instruments SA • Kriesbachstrasse 4 • 8600 Dübendorf • 41-1-8219444 • Fax: 41-1-8203081
TAIWAN:	Keithley Instruments Taiwan • 1, Ming-Yu First Street • Hsinchu, Taiwan, R.O.C. • 886-35-778462 • Fax: 886-35-778455

Model 485 Autoranging Picoammeter Instruction Manual

© 1984, Keithley Instruments, Inc.
Test Instrumentation Group
All rights reserved.
Cleveland, Ohio, U.S.A.
January 1990, Sixth Printing
Document Number: 485-901-01 Rev. F

SPECIFICATIONS

RANGE	RESOLUTION	ACCURACY (1 YEAR)	ANALOG RISE TIME (10 -90%)	NORMAL MODE	MAXIMUM CONTINUOUS INPUT‡
		18°-28°C ± (%rdg + counts)†		REJECTION RATIO (50 or 60Hz)	
2 nA	0.1pA	0.4 + 4	60ms	70dB	350Vdc
20 nA	1 pA	0.4 + 1	60ms	70dB	350Vdc
200 nA	10 pA	0.2 + 1	6ms	65dB	350Vdc
2 µA	100 pA	0.15 + 1	3ms	65dB	350Vdc
20 µA	1 nA	0.1 + 1	3ms	65dB	50Vdc
200 µA	10 nA	0.1 + 1	1ms	65dB	50Vdc
2mA	100 nA	0.1 + 1	1ms	55dB	50Vdc

† When properly zeroed.

‡ With no limiting resistance: 1000Vdc with external 100kΩ series resistance.

INPUT VOLTAGE BURDEN: Less than 200µV.

RANGING: Manual or autoranging.

AUTORANGING TIME: Average 250ms per range.

SETTLING TIME AT DISPLAY: Less than 1 second to within 2 counts on fixed range.

CONVERSION PERIOD: 300ms.

TEMPERATURE COEFFICIENT (0°-18°C & 28°-50°C): ±(0.1 × applicable accuracy specification) per °C.

MAXIMUM COMMON MODE VOLTAGE: 30V rms, DC to 60Hz sine wave.

ANALOG OUTPUT:

Output Voltage: +1V = -10000 counts, except +100mV = -10000 counts on 2nA range.

Output Resistance: 1000Ω.

REL: Pushbutton allows zeroing of on range readings. Allows relative readings to be made with respect to baseline value. Front panel annunciator indicates REL mode.

DATA STORE and MIN/MAX: 100 reading storage capacity; records data at one of six selectable rates from 3 readings/second to 1 reading/hour, or by manual triggering. Also detects and stores maximum and minimum readings continuously while in the data store mode.

LOG: Displays logarithm (base 10) of the absolute value of the measured current (examples: -3.000 = ±1mA; -6.301 = ±0.5µA).

IEEE-488 BUS IMPLEMENTATION (Option 4853)

MULTILINE COMMANDS: DCL, SDC, GET, GTL, UNT, UNL, SPE, SPD.

UNILINE COMMANDS: IFC, REN EOI, SRQ, ATN.

INTERFACE FUNCTIONS: SH1, AH1, T5, TE0, L4, LE0, SR1, RL2, PP0, DC1, DT1, C0, E1.

PROGRAMMABLE PARAMETERS: Zero Check, Range, REL, LOG, Trigger, Calibration, EOI, SRQ, Status, Output Format, Terminator.

GENERAL

DISPLAY: 4½ digit LCD, 0.5" height; polarity, range and status indication.

OVERRANGE INDICATION: "OL" displayed.

CONNECTORS:

Input: BNC.

Analog Output: Banana Jacks.

OPERATING ENVIRONMENT: 0-50°C, less than 70% R.H. up to 35°C; linearly derate 3% R.H./°C up to 50°C.

STORAGE ENVIRONMENT: -25° to +60°C

POWER: 105-125V or 210-250V (switch selected), 90-110V available, 50-60Hz, 12 VA.

DIMENSIONS, WEIGHT: 85mm high × 235mm wide × 275mm deep. (3½" × 9¼" × 10¾").

Net Weight: 1.8kg (4 lbs.)

ACCESSORIES AVAILABLE:

Model 1010:	Single Rack Mounting Kit
Model 1017:	Dual Rack Mounting Kit
Model 1684:	Hard Shell Carrying Case
Model 1758:	Rechargeable Battery Pack
Model 4801:	Low Noise Input Cable (4ft.), BNC to BNC
Model 4803:	Low Noise Cable Kit
Model 4853:	IEEE-488 Interface
Model 7008-3:	IEEE-488 Digital Cable (3ft.)
Model 7008-6:	IEEE-488 Digital Cable (6 ft.)
Model 8573:	IEEE-488 Interface for IBM PC

TABLE OF CONTENTS

SECTION 1—GENERAL INFORMATION		
1.1	Introduction	1-1
1.2	Getting Started	1-1
1.3	Unpacking and Inspection	1-1
1.4	Specifications	1-1
1.5	Warranty Information	1-1
1.6	Manual Addenda	1-2
1.7	Safety Symbols and Terms	1-2
1.8	Optional Accessories	1-2
SECTION 2—BENCH OPERATION		
2.1	Introduction	2-1
2.2	Preparation for Use	2-1
2.2.1	Line Power	2-1
2.2.2	Battery Pack Power	2-1
2.2.3	Battery Charging	2-1
2.3	Tilt Bail	2-1
2.4	Model 485 Familiarization	2-1
2.4.1	Display	2-1
2.4.2	Front Panel Controls	2-2
2.4.3	Input Connector	2-2
2.4.4	Analog Output Connectors	2-2
2.5	Error Messages	2-2
2.6	Environmental Condition	2-3
2.7	Basic Bench Measurements	2-3
2.7.1	Power-Up	2-4
2.7.2	Zero Check	2-4
2.7.3	Current Measurements	2-4
2.7.4	Relative Mode	2-4
2.7.5	LOG Mode	2-5
2.7.6	Inverting Analog Output	2-5
2.7.7	MIN/MAX and 100 Point Data Store	2-6
2.8	Measurement Considerations	2-6
2.8.1	Source Resistance	2-6
2.8.2	Source Capacitance	2-7
2.8.3	Leakage Resistance	2-8
2.8.4	Zero Time Stability	2-8
2.8.5	Grounding Considerations	2-8
2.9	Applications	2-8
2.9.1	Op Amp Offset Current	2-8
2.9.2	FET Gate Leakage and Channel Current	2-9
2.9.3	Insulation Leakage Currents and High Resistance	2-9
2.9.4	Phototube, Photodiode and Beam Currents	2-9
2.9.5	Resistivity Tests	2-10
SECTION 3—PERFORMANCE VERIFICATION		
3.1	Introduction	3-1
3.2	Environmental Conditions	3-1
3.3	Recommended Test Equipment	3-1
3.4	Initial Conditions	3-1
3.5	Verification Procedure	3-1

TABLE OF CONTENTS (CONT.)

SECTION 4—THEORY OF OPERATION		
4.1	Introduction	4-1
4.2	Overall Functional Description	4-1
4.3	Analog Circuitry	4-1
4.3.1	Current-to-Voltage Converter	4-1
4.3.2	Multiplexer	-2
4.3.3	Input Buffer Amplifier	4-2
4.3.4	-2V Reference Source	4-3
4.3.5	A/D Converter	4-3
4.4	Digital Circuitry	4-4
4.4.1	Microcomputer	4-4
4.4.2	Address Decoding	4-4
4.4.3	PIA	4-4
4.4.4	Display Board	4-4
4.5	Digital Calibration	4-4
4.6	Power Supply	4-4
4.7	Model 1758 Battery Option	4-4
SECTION 5—MAINTENANCE		
5.1	Introduction	5-1
5.2	Top Cover Removal/Installation	5-1
5.3	Battery Pack (Model 1758) Installation	5-1
5.4	Front Panel Calibration	5-1
5.4.1	Recommended Calibration Equipment	5-1
5.4.2	Calibration Jumper	5-2
5.4.3	Environmental Conditions	5-2
5.4.4	Calibration Procedure	5-2
5.4.5	Calibration Storage	5-2
5.5	Calibration Over IEEE-488 Bus	5-3
5.6	Troubleshooting	5-3
5.6.1	Recommended Test Equipment	5-3
5.6.2	Self Diagnostic Program	5-3
5.6.3	Power Supply and Battery Pack (Model 1758) Checks	5-6
5.6.4	A/D Converter and Display	5-6
5.6.5	Signal Conditioning	5-7
5.7	Input Amplifier (U105) Balancing	5-7
5.8	Line Fuse Replacement	5-7
5.9	Special Handling of Static Sensitive Devices	5-8
SECTION 6—REPLACEMENT PARTS		
6.1	Introduction	6-1
6.2	Replaceable Parts	6-1
6.3	Ordering Information	6-1
6.4	Factory Service	6-1
6.5	Component Location Drawings and Schematic Diagrams	6-1

LIST OF ILLUSTRATIONS

2-1	Model 485 Front Panel	2-2
2-2	Model 485 Inverting Analog Output	2-6
2-3	Simplified Model for Input Signal Conditioning	2-7
2-4	Test Fixture Guarding	2-8
2-5	Leakage Test Set Up Using Model 6104	2-8
2-6	Op Amp Input Offset Currents Measurement	2-8
2-7	FET Gate Leakage and Channel Currents Measurement	2-9
2-8	Insulation Leakage Currents and High Resistances Measurement	2-9
2-9	Set Up to Measure Photomultiplier, Photodiode and Beam Currents	2-9
2-10	Resistivity Test Set Up	2-10
3-1	Shielded Test Fixture	3-2
4-1	Simplified Block Diagram	4-1
4-2	Current-to-Voltage Converter	4-2
4-3	Simplified Schematic of the Multiplexer	4-2
4-4	Simplified Schematic of the Input Buffer Amplifier	4-2
4-5	A/D Converter	4-3
5-1	Segment Identification	5-4
5-2	Jumper Locations	5-7
6-1	Model 485 Miscellaneous Parts	6-2
6-2	Display Assembly	6-3
6-3	Mother Board, Component Location Drawing, Dwg. No. 485-100	6-7
6-4	Mother Board, Schematic Diagram, Dwg. No. 485-106	6-9
6-5	Display Board, Component Location Drawing, Dwg. No. 485-110	6-13
6-6	Display Board, Schematic Diagram, Dwg. No. 485-116	6-14
6-7	Model 1758 Battery Pack, Component Location Drawing, Dwg. No. 1758-100	6-15
6-8	Model 1758 Battery Pack, Schematic Diagram, Dwg. No. 1758-106	6-16

LIST OF TABLES

2-1	Error Messages	2-3
2-2	Range, Accuracy and Maximum Allowable Inputs	2-3
2-3	Equivalent Input Resistance With Zero Check Enabled	2-4
3-1	Recommended Test Equipment	3-1
3-2	Range Accuracy	3-2
5-1	Range Calibration	5-3
5-2	Recommended Troubleshooting Equipment	5-3
5-3	Troubleshooting Modes	5-5
5-4	Power Supply Checks and Battery Pack (Model 1758) Checks	5-6
5-5	A/D Converter Checks	5-6
5-6	Display Board Checks	5-7
5-7	Offset Jumper Set Up	5-7
5-8	Static Sensitive Devices	5-8
6-1	Mother Board, Parts List	6-4
6-2	Display Board, Parts List	6-13
6-3	Model 1758 Battery Pack, Parts List	6-15
6-4	Model 485 Spare Parts List	6-17

SAFETY PRECAUTIONS

The following safety precautions should be observed before operating the Model 485.

This instrument is intended for use by qualified personnel who recognize shock hazards and are familiar with the safety precautions required to avoid possible injury. Read over the manual carefully before operating this instrument.

Exercise extreme caution when a shock hazard is present at the instrument's input. The American National Standards Institute (ANSI) states that a shock hazard exists when voltage levels greater than 30V rms or 42.4V peak are present. **A good safety practice is to expect that a hazardous voltage is present in any unknown circuit before measuring.**

Do not exceed 30V rms between the input connector shell and earth ground.

Inspect the test leads for possible wear, cracks or breaks before each use. If any defects are found, replace with test leads that have the same measure of safety as those supplied with the instrument.

For optimum safety do not touch the test leads or the instrument while power is applied to the circuit under test. Turn the power off and discharge all capacitors, before connecting or disconnecting the instrument.

Do not touch any object which could provide a current path to the common side of the circuit under test or power line (earth) ground. Always make measurements with dry hands while standing on a dry, insulated surface, capable of withstanding the voltage being measured.

Do not exceed the instrument's maximum allowable input as defined in the specifications and operation section.

Safe operation and good measurement practice dictates use of an external resistor when necessary to limit input currents to less than 3mA.

Model 485 Addendum

The following information is supplied as a supplement to this manual in order to provide the user with the latest improvements. It is recommended that verification information be added to Section 3 of the Model 485 Instruction Manual and calibration information be added to Section 5.

This addendum contains complete procedures for verifying and calibrating the Model 485 using the Keithley Model 263 Calibrator/Source. Complete separate procedures are provided for performing digital calibration from either the front panel or over the IEEE-488 bus. Digital calibration over the bus is automated using a BASIC program run by the HP 85 computer.

PERFORMANCE VERIFICATION USING MODEL 263 CALIBRATOR/SOURCE

Use of the Model 263 to verify accuracy specifications of the Model 485 simplifies the procedure by eliminating the need for user designed current sources. The equipment listed in Table 3-1 of the manual is not needed.

Ideally, performance verification should be performed when the instrument is first received to ensure that no damage or change in calibration has occurred during shipment. It may also be performed when instrument accuracy is suspect or following calibration. If performance on any of the ranges is outside the specified limits, calibrate the instrument.

NOTE

If the instrument does not meet specifications and is still under warranty (less than 12 months since date of shipment), contact your Keithley representative or the factory to determine the action to be taken.

Environmental Conditions

All measurements should be made at an ambient temperature between 18° and 28°C (65° to 82°F) with a relative humidity less than 70%.

Initial Conditions

Before performing the verification procedure, make sure the Models 485 and 263 meet the following conditions:

1. If the instruments have been subject to temperatures below 18°C (65°F) or above 28°C (82°F), allow sufficient time for the instruments to reach temperatures within the range. Generally, it takes one hour to stabilize an instrument that is 10°C (18°F) outside of the specified range.

2. Turn on the Models 485 and 263, and allow them to warm up for one hour. The Model 485 may be operated from either line power or battery pack power, as long as the battery pack has been fully charged.

Verification Procedure

Proceed as follows to verify the accuracy of the Model 485:

1. On the Model 485, press ZERO CHECK and select the 2nA range.
2. With an open input, adjust the ZERO pot for .0000 ±1 count on the display.
3. Connect the Model 263 to the Model 485 as shown in Figure 1. Make sure the calibrator is in standby.
4. Release ZERO CHECK on the Model 485.
5. Using the AMPS (active) current source, program the Model 263 to output 1.90000nA and verify that the reading is within the limits in Table 1.
6. Using Table 1 as a guide, check the rest of the current ranges by applying the appropriate current and verifying that the reading is within the allowable limits.

Table 1. Range Accuracy

485 Range	263 Output (AMPS)	Allowable Reading* (18°C -28°C)	
2 nA	1.90000 nA	1.8933	to 1.9067
20 nA	19.0000 nA	18.936	to 19.064
200 nA	190.000 nA	189.69	to 190.31
2 μA	1.90000 μA	1.8976	to 1.9024
20 μA	19.0000 μA	18.986	to 19.014
200 μA	190.000 μA	189.86	to 190.14
2mA	1.90000mA	1.8986	to 1.9014

*Includes Model 263 error.

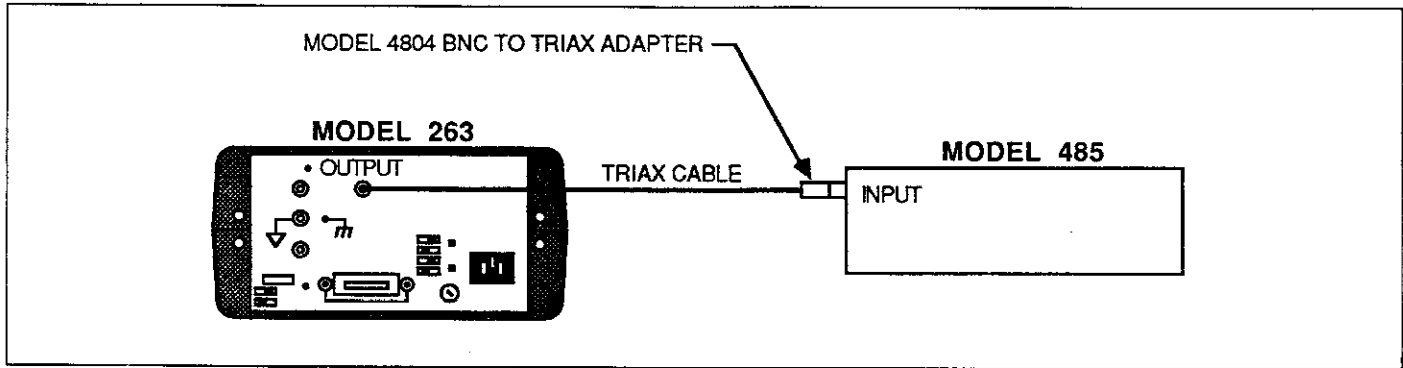

Figure 1. Model 485 Verification Connections

CALIBRATION USING MODEL 263 CALIBRATOR/SOURCE

The following paragraphs provide detailed procedures for calibrating the Model 485 Picoammeter using the Model 263 Calibrator/Source. All but one of the calibration adjustments are digital and can be done from the front panel or over the IEEE-488 bus.

To calibrate the instrument from the front panel, perform the following procedures, omitting paragraph "IEEE-488 Bus Calibration". To calibrate the Model 485 over the IEEE-488 bus, perform the following procedures, omitting paragraph "Front Panel Calibration".

Calibration Storage Enable

The Model 485 must be in calibration storage enable to store calibration constants in NVRAM. If the instrument is not placed in this mode, subsequent calibration will be lost when the instrument is turned off. Perform the following steps to enable calibration storage.

1. If the Model 485 is presently on, turn it off.
2. While holding in the STO/CLR button, turn the instrument back on.
3. When the "CAL" message is displayed, release the STO/CLR button. The instrument will return to the normal display mode and the storing of calibration constants is now enabled.

Required Equipment

The following items (one of each) are necessary to calibrate the Model 485:

1. Keithley Model 263 Calibrator/Source.
2. Triax to Triax Cable (supplied with 263)
3. Keithley Model 4804 Male BNC to Female Triax Adapter.

NOTE: The following additional items will be necessary if calibration is to be performed over the IEEE-488 bus.

4. Keithley Model 4853 IEEE-488 Interface installed in the Model 485.
5. HP 85 Computer equipped with HP 82937 GPIB Interface and I/O ROM.
6. Keithley Model 7008 IEEE cable.

Environmental Conditions

Calibration should be performed under laboratory conditions having an ambient temperature of $23 \pm 1^\circ\text{C}$ and a relative humidity of less than 70%. With both the Model 485 and 263 on, allow them to warm up for one hour. If either instrument has been subjected to extreme temperature or humidity, allow at least one additional hour for the instrument to stabilize before beginning the calibration procedure.

NOTE

Calibration can be stopped at any time and only those ranges out of specification need be calibrated.

Front Panel Calibration

Perform the following steps to calibrate the Model 485 from the front panel:

1. On the Model 485, depress ZERO CHECK and select the 2nA range.
2. With an open input, adjust the ZERO pot for $.0000 \pm 1$ count on the display.

NOTE

If Q104, U105, R113, R114 or R115 have been replaced, the picoammeter may not zero. See paragraph 5.7 in the Model 485 Instruction Manual for the procedure to balance the input amplifier.

3. Connect the output of the Model 263 Calibrator/Source to the input of the Model 485 as shown in Figure 2. Make sure the calibrator is in standby.
4. On the Model 485, press the REL and LOG push-buttons simultaneously and hold in until the message "CAL" is displayed. Release the buttons. The unit is now in the calibration mode as indicated by the "CAL" annunciator.
5. Release ZERO CHECK on the Model 485.
6. Program the Model 263 to output $.00000 \text{ nA}$. Use the AMPS (active) current source.
7. The Model 485 may be displaying a small offset (≈ 1 count). To cancel this offset, press REL on the Model 485 to zero the display.
8. Program the Model 263 to output 1.90000 nA .
9. Adjust the display of the Model 485 to read 1.9000 nA using the STO/CLR and RCL buttons. The STO/CLR button increments the displayed reading and the RCL button decrements the displayed reading.

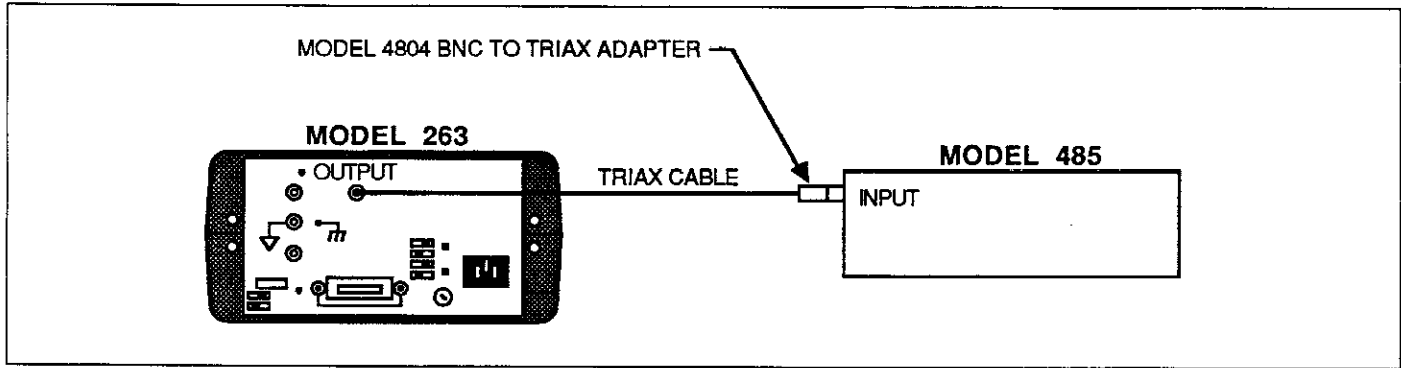

Figure 2. Model 485 Calibration Connections

10. Using Table 2 as a guide, repeat the basic procedure outlined in steps 5 through 9 to calibrate the rest of the current ranges of the Model 485.
11. To store calibration constants and exit the calibration mode, simultaneously press the REL and LOG buttons until the message "Stor" is displayed. If instead the message "out" is displayed, then calibration storage was not enabled and calibration constants will be lost when the Model 485 is turned off.

Table 2. Model 485 Range Calibration

485 Range	263 Output Current	485 Reading
2 nA	1.90000 nA	1.9000nA
20 nA	19.0000 nA	19.000 nA
200 nA	190.000 nA	190.00 nA
2 μ A	1.90000 μ A	1.9000 μ A
20 μ A	19.0000 μ A	19.000 μ A
200 μ A	190.000 μ A	190.00 μ A
2mA	1.9000 mA	1.9000mA

IEEE-488 Bus Calibration

Perform the following steps to calibrate the Model 485 over

the IEEE-488 bus using the Model 263 Calibrator/Source.

1. Connect the Models 263 and 485 to the GPIB interface of the HP 85 computer. The Model 485 must have a Model 4853 IEEE-488 Interface installed.
2. Make sure the IEEE-488 address of the Model 263 is set to 8 and the address of the Model 4853 is set to 22.
3. Enter the calibration program into the HP 85 computer.
4. To calibrate the instrument, simply press the RUN key on the computer. The program will prompt for the only manual adjustment and then automatically calibrate all the current ranges of the Model 485.
5. The program will prompt for storage of the calibration constants (line 330). This provides the user the opportunity to stop at this point to avoid permanent calibration. The calibration constants will be lost when the Model 485 is turned off.
6. Storage of calibration constants is performed on line 350 of the program and is indicated by the "Stor" message on the Model 485. If instead the message "out" is displayed, calibration storage was not enabled and calibration constants will be lost when the Model 485 is turned off.
7. After calibration is completed, it is recommended that you source a current from the Model 263 to each range at \pm half scale to verify accuracy.

```

10 CLEAR 722 @ CLEAR
20 WAIT 1000
30 OUTPUT 722 ; "C1R1X" ! 485; set to 2nA range and enable ZERO CHECK.
40 BEEP @ DISP "ADJUST 'ZERO' POT ON 485 FOR .0000 +/-1 COUNT."
50 DISP
60 DISP "IF DISPLAY WILL NOT ZERO, PRO- CEED TO PARAGRAPH 5.7 IN THE 48SMANUAL.
70 DISP
80 DISP "PRESS 'CONT' KEY ON THE HP 85 TOCONTINUE."
90 PAUSE
100 CLEAR @ BEEP
110 DISP "CONNECT 263 OUTPUT TO 485 INPUT (SEE FIGURE 2).'"
120 DISP
130 DISP "PRESS 'CONT' TO CONTINUE."
140 PAUSE
150 DATA 1,.0000000019,2,.0000000019,3,.00000019,4,.0000019,5,.000019,6,.00019,7,
160 CLEAR
170 CLEAR 708
180 OUTPUT 708 ; "F1R4V1.9E-9X" ! 263; program for 1.9nA.
190 OUTPUT 722 ; "C0X" ! 485; disable ZERO CHECK.
200 FOR I=4 TO 10
210 READ J
220 OUTPUT 722 ; "R";J;"X" ! 485; select range.
230 OUTPUT 708 ; "R";I;"X" ! 263; select range.
240 OUTPUT 708 ; "Z101X" ! 263; output zero amps.
250 WAIT 3000
260 OUTPUT 722 ; "Z1X" ! 485; enable REL to cancel offset.
270 READ J@ WAIT 2000
280 OUTPUT 708 ; "Z0X" ! 263; source programmed output.
290 WAIT 2000
300 OUTPUT 722 ; "V";J;"X" ! 485; send calibration value.
310 OUTPUT 722 ; "Z0X" ! 485; disable REL.
320 NEXT I
330 BEEP @ DISP "TO STORE CAL CONSTANTS, PRESS 'CONT'."
340 PAUSE
350 OUTPUT 722 ; "L0X" ! 485; store cal constants.
360 CLEAR @ BEEP
370 DISP "CALIBRATION COMPLETE"
380 END

```

485 CALIBRATION PROGRAM

MODEL 485 AUTORANGING PICOAMMETER

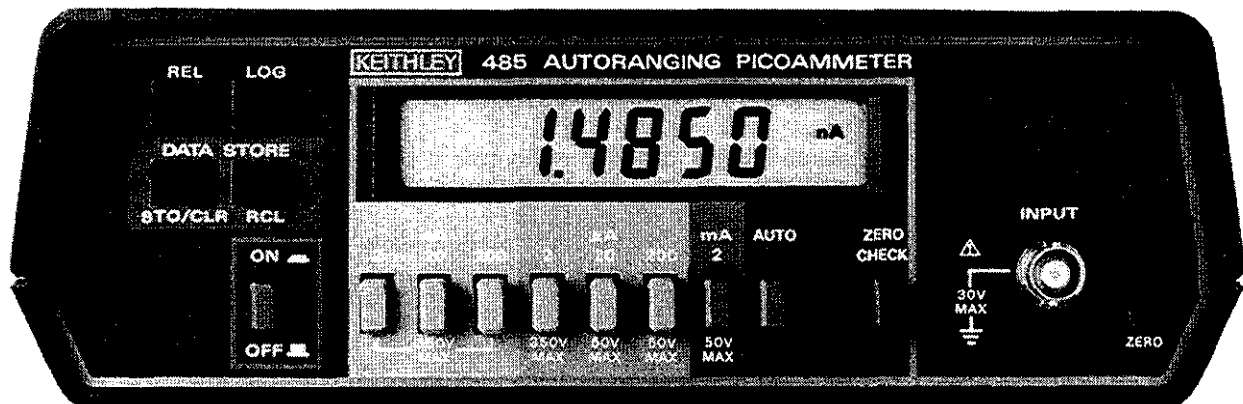

Features:

- 4½ Digit LCD Display
- Fast Autoranging
- Bench or Portable
- Digital Calibration
- 100 Point Data Store
- 0.1pA Sensitivity
- Analog Output
- LOG/Relative Functions
- Min/Max Reading Hold

Options:

- Model 1758 Rechargeable Battery Pack
- Model 4853 IEEE-488 Interface

SECTION 1

GENERAL INFORMATION

1.1 INTRODUCTION

This instruction manual contains the necessary information for operating and maintaining the Model 485 Autoranging Picoammeter and the Model 1758 Rechargeable Battery Pack. The information is divided into the following sections:

1. Section 1 contains general information and provides guidelines for using this manual. Important safety information is also presented here.
2. Section 2 contains detailed operation information for the Model 485.
3. Section 3 contains the information needed to verify the accuracy of the Model 485. Performance verification can be done upon receipt of the unit or whenever the basic accuracy is in question.
4. For the more technically oriented, information on theory of operation, maintenance and servicing is contained in Section 4 through 6.

NOTE

The Model 4853 IEEE-488 interface comes supplied with its own instruction manual.

1.2 GETTING STARTED

Perform the following steps in sequence to acquaint yourself quickly and safely with the basic operation of the Model 485.

1. Verify that the Model 485 was not damaged in transit, as explained in paragraph 1.3.
2. Carefully read the safety precautions and warnings found preceding this section and the first two sections (General Information and Bench Operation) of this manual.
3. Referring to paragraph 2.2.1 (Line Power) set the line voltage switch and plug the power cord into a properly grounded outlet. If the optional battery pack is installed the charge circuitry will be activated.
4. Acquaint yourself with the controls and display of the Model 485 as follows:
 - A. Turn on the Model 485 by pressing in the ON/OFF pushbutton. All the zeroes will be displayed briefly.
 - B. Select autoranging by pressing in the AUTO pushbutton. The nA and AUTO annunciators will be displayed. Pressing any of the other range pushbuttons will put the Model 485 in manual ranging as indicated by the absence of the AUTO annunciator.
 - C. Engage the ZERO CHECK pushbutton and note that the ZERO CHECK annunciator turns on. Release the ZERO CHECK button.
 - D. Select LOG by pressing the LOG pushbutton. The LOG annunciator will turn on. Press the LOG button

again to take the Model 485 out of the LOG measurement mode.

- E. REL (relative) can be used in the linear measurement mode or the logarithm measurement mode. The stored REL level will be subtracted from all subsequent measurements. Press the REL pushbutton and note that the REL annunciator turns on.
 - F. To activate the 100 point DATA STORE with Min/Max, press and hold in the STO/CLR pushbutton. When the reading rate $r = 0$ is displayed let go of the button. The STO annunciator will turn on. Press the RCL pushbutton and the last data point will be displayed briefly followed by the reading (data). Other data points can be displayed by holding in the RCL button. Turn off the DATA STORE by pressing the STO/CLR pushbutton again.
5. When you are comfortable with the controls of the Model 485, go on and make the desired measurements using Section 2, Bench Operation as a guide.

1.3 INSPECTION

The Model 485 Bench Picoammeter was carefully inspected, both mechanically and electrically, before shipment. Upon receiving the Model 485, check for any obvious signs of physical damage that might have occurred during shipment. Report the damage to the shipping agent immediately. Retain the original packing materials in case reshipment becomes necessary. The following items are included with every Model 485 order:

- Model 485 Autoranging Picoammeter
- Model 485 Instruction Manual
- Additional accessories as ordered.

If an additional instruction manual is required, order the manual package (Keithley Part Number 485-901-00). The manual package includes an instruction manual and all pertinent addenda.

1.4 SPECIFICATIONS

Detailed Model 485 specifications may be found immediately preceding the table of contents of this manual.

1.5 WARRANTY INFORMATION

Warranty information may be found on the inside back cover of this manual. Should it be necessary to exercise the warranty, contact your Keithley representative or the factory to determine the correct course of action. Keithley Instruments maintains service facilities in the United States, West Germany, Great Britain, France, the Netherlands, Switzerland

and Austria. Information concerning the application, operation or service of your instrument may be directed to the applications engineer at any of these locations. Check the inside front cover of this manual for addresses.

1.6 MANUAL ADDENDA

Information concerning improvements or changes to the instrument which occur after the printing of this manual will be found on an addendum sheet included with this manual. Be sure to review these changes before attempting to operate or service the instrument.

1.7 SAFETY SYMBOLS AND TERMS

The following safety symbols and terms are used in this manual or found on the Model 485.

The symbol  on the instrument indicates that the user should refer to the operating instructions in this manual.

The **WARNING** heading in this manual explains dangers that could result in personal injury or death.

The **CAUTION** heading in this manual explains hazards that could damage the instrument.

1.8 OPTIONAL ACCESSORIES

The following accessories can be used with the Model 485.

Model 1010 Single Rack Mounting Kit—Use to mount one Model 485 in a standard 5¼ × 19" rack.

Model 1017 Dual Rack Mounting Kit—Use to mount two Model 485's in a standard 5¼ × 19" rack.

Model 1684 Hard Shell Carrying Case—Hard vinyl case, 100mm × 300mm × 350mm (4 × 13 × 14 inches) has a fitted foam insert with room for the Model 485, instruction manual and small accessories.

Model 1758 Rechargeable Battery Pack—Provides six hours minimum operation from full charge, recharges within 10 hours and is field installable.

Model 4801 Input Cable—A low noise coaxial cable four feet (1.2m) in length with a male BNC connector on each end.

Model 4803 Low Noise Cable Kit—Consists of 50 feet (15.2m) of low noise coaxial cable, 10 male BNC connectors, and five female chassis mount BNC connectors.

Model 4853 IEEE-488 Interface—Field installable programmable option provides isolated data output. Switch-selectable talk only or addressable modes. Mounts within and powered by the Model 485.

Model 7008 IEEE-488 Digital Cable—Useful for connecting the Model 4853 to the IEEE-488 bus. The Model 7008-3 is 0.9m (3 ft) in length and has a standard IEEE-488 connector at each end. The Model 7008-6 is 1.8m (6 ft) in length.

Model 8573 IEEE-488 Interface for IBM PC—Field installable programmable option provides data output for the IBM PC. Mounts within and powered by the IBM PC.

SECTION 2 BENCH OPERATION

2.1 INTRODUCTION

This section contains the information needed to prepare and operate the Model 485 as a bench picoammeter. Bench operation consists of using the Model 485 to perform basic current measurements. Data store operation is also covered. The capabilities of the Model 485 can be enhanced with the addition of the Model 4853 IEEE-488 interface. IEEE operation is covered in the Model 4853 Instruction Manual.

2.2 PREPARATION FOR USE

2.2.1 Line Power

The Model 485 is provided with a three-wire line cord which mates with third-wire grounded receptacles. Connect the instrument to AC line power as follows:

1. Set the LINE VOLTAGE switch on the back of the instrument to correspond to line voltage available. Ranges are 105-125V or 210-250V 50/60Hz AC.

CAUTION

Connect only to the line voltage selected. Application of incorrect voltage can damage the instrument.

2. Plug the power cord into a properly grounded outlet.

WARNING

Ground the instrument through a properly grounded receptacle before operation. Failure to ground the instrument can result in severe injury or death in the event of short circuit or malfunction.

NOTE

Although the Model 485 is specified at 50Hz and 60Hz the instrument may be operated at 400Hz and 440Hz. Add one count to instrument specifications under this condition.

2.2.2 Battery Pack Power

The Model 485 may also be operated from rechargeable sealed nickel-cadmium batteries contained in the optional Model 1758 Rechargeable Battery Pack. The battery pack will operate the Model 485 for up to six hours. The BAT annunciator will turn on when the battery charge is insufficient to maintain accurate readings. Refer to Section 5, paragraph 5.3 for installation procedures.

2.2.3 Battery Charging

After the Model 1758 Battery Pack is installed in the Model 485 it can be charged and recharged as follows:

1. Connect the instrument to line power as described in paragraph 2.2.1.
2. With the power switch off, the battery charge circuitry is automatically energized to charge the battery at the maximum rate. When the battery pack is first installed, or if it is completely discharged, allow it to charge for ten hours.

NOTE

For maximum battery efficiency only charge the battery pack after it has become discharged and only charge until it is fully charged (10 hours). Continuous charging over long periods of time will not damage the batteries but, useful life will gradually decrease. This loss is not permanent and may be restored by cycling the battery pack through several complete charge/discharge cycles. The battery pack is capable of 500 to 1000 charge/discharge cycles before replacement is needed.

Do not make measurements with the BAT annunciator on as the readings may be erroneous.

3. When the Model 485 is in use on line power, the battery charger maintains a trickle charge on the battery pack.

2.3 TILT BAIL

The Model 485 is equipped with a tilt bail which makes it possible to elevate the instrument to a convenient viewing position. To change the bail position, pull out the bail handle from each side of the case until it rotates freely; rotate the bail to the desired position and release the bail to allow it to lock into place.

2.4 MODEL 485 FAMILIARIZATION

The following paragraphs and Figure 2-1 provides a brief description of the display, front panel controls and connectors.

2.4.1 Display

The Model 485 has a 4½ digit liquid crystal display (LCD). The minus sign is displayed. The plus sign is implied by the absence of the minus sign. The following annunciators are displayed on the LCD.

BAT—Low battery indicator for the Model 1758.
nA, μ A or mA—Nanoamps, Microamps or Milliamps selected.
RMT (Remote)—Model 485 being controlled over the IEEE-488 bus (Model 4853 installed).
CAL—Model 485 in calibration mode.
AUTO—Autorange selected.
REL—Relative selected.
LOG—Logarithm selected.
ZERO CHECK—Zero Check selected.
STO—Data being stored.
RCL—Data being recalled. RCL flashes when buffer is full during store cycle.

2.4.2 Front Panel Controls

ON/OFF—Pressing in this pushbutton turns the Model 485 on. Releasing (out) this pushbutton turns the instrument off.
ZERO CHECK and ZERO—This pushbutton and trimpot are used to zero the instrument's internal offsets.
REL (Relative)—This pushbutton is used to cancel measurement offsets or store the input signal as a reference level. Pressing this button again shuts REL off.
LOG—This pushbutton selects the logarithm function. The displayed current measurement is expressed as the logarithm (base 10) of the measured current referenced to one ampere. Pressing this button again shuts LOG off.
DATA STORE—Has MIN/MAX and 100 point reading storage capacity; records data at one of seven selectable rates. Records minimum and maximum conversion during the period the data store is active at the rate of 3/sec.

1. **STO/CLR**—Pressing this button initiates the storage sequence. Pressing the button a second time shuts off the data store when in $r=0$ through $r=5$. When in $r=6$, pressing this button stores one reading.
2. **RCL**—Pressing and holding this button in scrolls the data pointer. To read the data at a particular point, simply release the button.

Range Pushbuttons

1. **Auto**—This pushbutton selects autoranging.
2. Manual ranging is accomplished by depressing the appropriate range button.

2.4.3 Input Connector

The input connector is a standard BNC type.

2.4.4 Analog Output Connectors

A voltage level that is proportional to the incoming current can be monitored using the analog output banana jacks located on the rear panel.

2.5 ERROR MESSAGES

Table 2-1 lists the error messages associated with basic front panel operation. Note that the instrument has a number of other messages that are discussed in the appropriate sections of this manual.

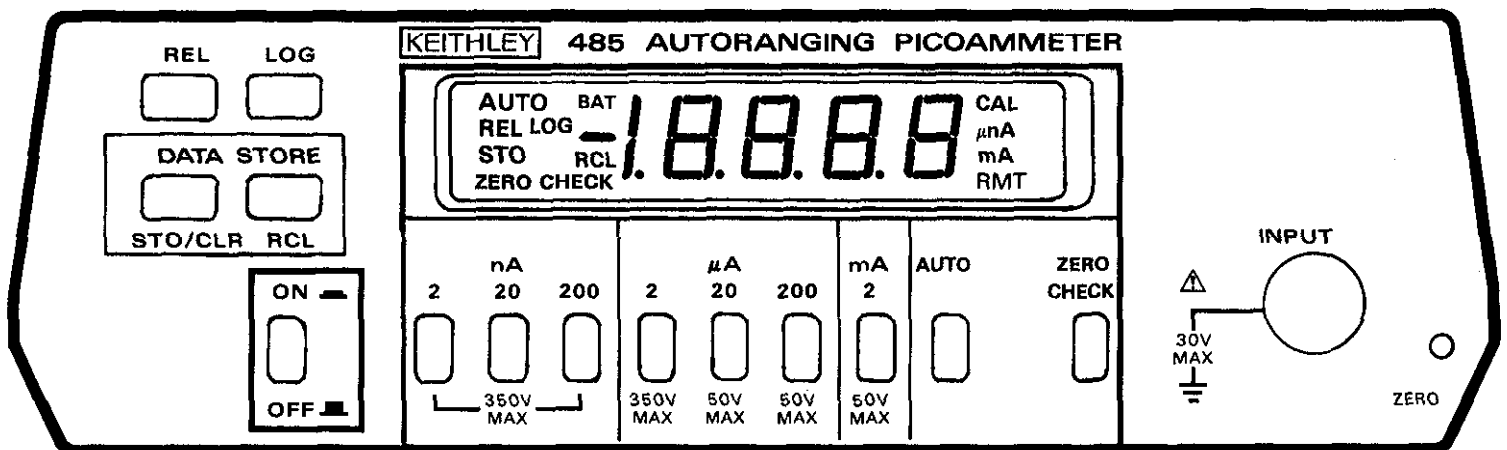

Figure 2-1. Model 485 Front Panel

Table 2-1. Error Messages

Display	Message	Comments
0000	RAM Error	Model 485 locks up. See Section 5 for troubleshooting information.
cErr	Calibration Error (NVRAM Failure)	Model 485 locks up, but operation can be restored by pressing any one of the four momentary pushbuttons. If restored, calibration is invalid as indicated by the flashing "CAL" annunciator. See Section 5 for troubleshooting information.
OL	Overrange	Overrange input applied to the Model 485. Leading minus sign indicates that input signal has a negative value.

2.6 ENVIRONMENTAL CONDITIONS

All measurements should be made at an ambient temperature within the range of 0°C to 50°C, and with a relative humidity of 0% to 70% up to 35°C. For instruments above 35°C derate humidity 3% per °C up to 50°C. If the instrument has been subjected to extremes of temperature, allow sufficient time for internal temperatures to reach environmental conditions. Typically, it takes one hour to stabilize a unit that is 10°C (18°F) out of specified temperature range.

2.7 BASIC BENCH MEASUREMENTS

Basic measurement techniques for using the Model 485 to measure DC current are covered in the following paragraphs. Also included is the operation of the Min/Max and 100 point data store. A summary of range, accuracy and maximum allowable input information is given in Table 2-2.

WARNING

Before operating the Model 485, observe the safety precautions found preceding Section 1. Failure to observe these and other safety precautions found in this manual could result in severe injury or death.

WARNING

Do not exceed 30V RMS between input low and power line ground or a shock hazard will result. Also, current inputs that exceed 3mA may be erroneously displayed as an on-scale reading.

CAUTION

Do not exceed the maximum input limits shown in Table 2-2.

Table 2-2. Range, Accuracy and Maximum Allowable Inputs

Range	Maximum Reading (Note 1)	Accuracy ± (%Reading + Counts) 18°C -28°C	Minimum Recommended Source Resistance (Note 2)	Maximum Allowable Input (Note 3)
2 nA	1.9999 nA	0.4 + 4	100MΩ	350V
20 nA	19.999 nA	0.4 + 1	100MΩ	350V
200 nA	199.99 nA	0.2 + 1	10MΩ	350V
2 μA	1.9999 μA	0.15 + 1	1MΩ	350V
20 μA	19.999 μA	0.1 + 1	100 kΩ	50V
200 μA	199.99 μA	0.1 + 1	10 kΩ	50V
2mA	1.9999mA	0.1 + 1	1 kΩ	50V

NOTE:

1. Current above maximum will result in an "OL" display.
2. Source resistances lower than these may result in higher instrument noise and drift.
3. Maximum Transient Overload Voltage: 1000V with a series 100kΩ resistor. Safe operation and good measurement practice dictates use of an external resistor when necessary to limit input currents to less than 3mA.

Maximum volts-hertz product (common mode): 10⁶V•Hz

2.7.1 Power-Up

NOTE

The software revision level of the Model 485 can be displayed upon power-up by running the diagnostic program. See Section 5, Maintenance, for more information.

Turn on the Model 485 by pressing in the ON/OFF switch. The following will occur automatically:

1. Reset—All zeroes will be briefly displayed before going into the measurement mode.
2. RAM Test—If this test fails the Model 485 will lock up with zeroes displayed.
3. NVRAM Test—This test determines if the calibration constants are properly read from NVRAM. If this test fails the display will show the error message "cErr".

Refer to Table 2-1 for more information pertaining to error messages.

CAUTION

During power up and power down, using AC line or battery pack, a current surge (5mA, 5V maximum) can appear at the INPUT of the Model 485. Protect any circuitry that would be damaged by these levels by making circuit connections only after turning on the Model 485. Disconnect these circuits before turning off the Model 485.

2.7.2 Zero Check

The instrument should be properly zeroed (after one hour warm-up) before making any current measurements. Only the 2nA current range needs to be zeroed. To check or adjust zero, proceed as follows:

1. Select the 2nA range.
2. Turn off REL and LOG if they are on.
3. Depress the ZERO CHECK pushbutton. Momentary or locking action can be achieved depending on how far the button is depressed. To adjust zero, place the pushbutton in to the lock position.
4. Adjust zero level trimpot via access hole on front panel for a zero indication on the digital display.
5. Release the ZERO CHECK button.

In normal operation, the equivalent input resistance of the 485 picoammeter is equal to or less than the maximum burden voltage (200 μ V) divided by the maximum range current. This does not hold while in zero check or overload conditions because the feedback to the input node is broken. Values of input impedance for normal operation and zero check/overload are shown in Table 2-3.

NOTES

1. When zero is properly adjusted, the input voltage burden for an on-range reading will be less than or equal to 200 μ V.
2. The REL feature can be used instead of the ZERO pot to zero the display. However, REL then cannot be used to cancel a measurement offset or establish a reference level.

Table 2-3. Equivalent Input Resistance With Zero Check Enabled

Current Range	Maximum Effective Input Resistance	Impedance In Zero Check/Overload
2 nA	100k Ω	9M Ω 230pF
20 nA	10k Ω	9M Ω 230pF
200 nA	1k Ω	5M Ω 230pF
2 μ A	100 Ω	900k Ω 230pF
20 μ A	10 Ω	100k Ω 0.01 μ F
200 μ A	1 Ω	10k Ω 0.01 μ F
2mA	0.1 Ω	1k Ω 0.01 μ F

2.7.3 Current Measurements

1. Zero the instrument as described in paragraph 2.7.2.
2. Select a current range that is appropriate for the expected input level or select autorange.
3. Connect the source to the INPUT connector on the front panel. Low-noise cable and connector accessories described in Section 1 should be used as required. Measurement considerations are discussed in paragraph 2.8. A summary of range, accuracy and input overload information is given in Table 2-2.
4. Read the input current on the digital display. Overrange is indicated by an "OL" message.

2.7.4 Relative Mode

When the relative mode is selected with an on-scale reading on the display the following occurs:

1. The REL annunciator is displayed.
2. The next reading is stored.
3. The stored reading is then algebraically subtracted from all subsequent readings and displayed.

A REL level can be established for the linear measurement mode or the logarithm measurement mode and is effective only in that mode. Changing modes will not affect a REL level already established. However, if another REL level is set (in the other measurement mode) the previous REL level will be cancelled. For example, place the Model 485 in the logarithm mode (LOG annunciator on) and select the 2 μ A range. With an open input, note the approximate -10.0 reading on the display. Press the REL button and note that the REL annunciator is on and that display is zeroed. Select the linear measurement mode by pressing the LOG button (LOG annunciator off). Note that the REL annunciator is off, indicating that there is not a REL level established for the linear measurement mode. Switch back to the LOG mode and note

that the REL level is still there. Again, go back to the linear measurement mode (LOG off) and set a REL level of $1\mu\text{A}$. The REL annunciator will turn on. Switch back to the LOG mode and note that the REL annunciator is off, indicating that the REL level for the LOG mode is cancelled.

Once a REL level is established for a measurement mode, that stored level will be the same regardless of what range the Model 485 is on. For example, if $+1\mu\text{A}$ is established as the REL level on the $20\mu\text{A}$ range, $+1\mu\text{A}$ will also be the REL level on the 2mA range.

It is important to note that the use of REL reduces the dynamic range of measurements by that level. For instance, assume that the REL level is $+1\mu\text{A}$ and the Model 485 is manually set to the $2\mu\text{A}$ range. The maximum positive displayed reading (before overranging), would be $+0.9999\mu\text{A}$. This is because the A/D converter would be seeing $1.9999\mu\text{A}$ (maximum) from the input. Thus, the dynamic range of measurement is $-1.9999\mu\text{A}$ to $+0.9999\mu\text{A}$ ($2.9998\mu\text{A}$) as compared to the normal $-1.9999\mu\text{A}$ to $+1.9999\mu\text{A}$ ($3.9998\mu\text{A}$). The dynamic range of measurement has been reduced by $1\mu\text{A}$. The effects on dynamic range can be reduced by selecting a higher range or using autorange.

2.7.5 LOG Mode

The Model 485 can make logarithm measurements referenced to a 1A current level or to other current levels with the use of the REL feature.

The basic procedure for using the LOG mode is to select auto range and press the LOG button (LOG annunciator on). To get out of the LOG mode, press the LOG button again. The LOG annunciator will turn off.

Because the logarithm of a negative number is undefined, the logarithm is taken with the absolute value of the measured current.

NOTE

LOG measurements must always be made on the lowest possible range (without overranging). Readings on high ranges will not allow optimum calculations of the logarithm. When in doubt, use Auto Range.

- 1. Log Measurements with 1A reference current:** The LOG measurement mode displays the absolute value of the logarithm (base 10) of the input current referenced to 1A . The following equation illustrates this relationship:

$$\text{LOG Reading} = \text{Log} \left| \frac{\text{Applied Current}}{1\text{A}} \right|$$

Using this reference current, the LOG reading span is from $-13.0 (\pm 0.1\text{pA})$ to $-2.699 (\pm 1.9999\text{mA})$.

The following examples compute the expected LOG readings for various current levels applied to the Model 485:

- 1nA

$$\begin{aligned} \text{LOG reading} &= \text{LOG} \left| \frac{1\text{nA}}{1\text{A}} \right| \\ \text{LOG reading} &= -9.000 \end{aligned}$$

- $0.5\mu\text{A}$

$$\begin{aligned} \text{LOG reading} &= \text{LOG} \left| \frac{0.5\mu\text{A}}{1\text{A}} \right| \\ \text{LOG reading} &= -6.301 \end{aligned}$$

- -1mA

$$\begin{aligned} \text{LOG reading} &= \text{LOG} \left| \frac{-1\text{mA}}{1\text{A}} \right| \\ \text{LOG reading} &= -3.000 \end{aligned}$$

To make LOG measurements reference to 1A , proceed as follows:

- Zero the instrument, if required, as described in paragraph 2.7.2.
 - Select auto range on the Model 485.
 - Connect the source to the Model 485.
 - Press the LOG button.
 - Take the LOG reading from the display.
- 2. Log measurements using other reference currents:** LOG measurements, referenced to other current levels, can be read directly from the display of the Model 485 by utilizing the REL feature and an accurate current source.

To make LOG measurements referenced to another current level, proceed as follows:

- Zero the instrument, if required, as described in paragraph 2.7.2.
- Set the Model 485 to auto range.
- Input the reference current to the Model 485.
- With the Model 485 in the LOG mode, press the REL button. The REL annunciator will turn on and the display will zero.
- Remove the reference current source from the Model 485.
- The Model 485 is now set up to make LOG measurements referenced to that current level. Simply input the current to be measured and take the reading from the display.

2.7.6 Inverting Analog Output

Two banana jacks, accessible from the rear panel, permit monitoring or recording of the output from the current-to-voltage converter within the Model 485. Since the Model 485 is a feedback picoammeter, as shown in Figure 2-2, the input current is forced through the feedback resistor and an in-

verted analog output voltage is developed by the operational amplifier. The feedback (Range) resistors are selected such that voltage for an on-scale reading on the 2nA range will be between zero and $\pm 200\text{mV}$. The output voltage for the rest of the ranges will be between zero and $\pm 2\text{V}$. The relationship between the analog output signal and the digital display is as follows:

2nA Range: 10000 counts = -100mV , or $-10\mu\text{V}/\text{count}$
 20nA-2mA Ranges: 10000 counts = -1V or $-100\mu\text{V}/\text{count}$

The analog output is input protected up to 20V RMS and during an input current overload the analog output is clamped to a maximum voltage swing of approximately $\pm 4\text{V}$. Although protected up to 20V to prevent instrument damage, a voltage applied to the analog output could cause an erroneous display, rather than the "OL" message.

Since the output of the current-to-voltage converter is bipolar, the inverting analog output can also be used to measure low frequency AC current which falls within the specified analog rise time. The inverting analog output resistance is $1.01\text{k}\Omega$; 910Ω in series with the signal leads and 100Ω in series with the ground lead.

Typical Analog Output Accuracy:
 Linearity: $< 0.1\%$ full scale
 Gain Accuracy: $\pm 1\%$
 Output Resistance: $\pm 5\%$

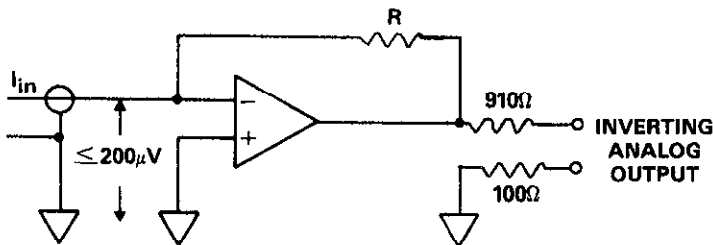

Figure 2-2. Model 485 Inverting Analog Output

2.7.7 Min/Max and 100 Point Data Store

The data store can save up to 100 readings and store the minimum and maximum readings recorded during the period that the data store is active. The 100 points of data are stored at one of six selectable rates. Manual data entry ($r=6$) is also available. Readings for minimum and maximum are sampled at the rate of three per second regardless of the selected rate. The minimum and maximum readings are continuously updated while in the data store mode. The procedure for operating the data store is as follows:

1. Connect the desired measurement configuration to the Model 485. Make sure that the controls of the Model 485 are set appropriately.
2. Storing Data:
 - A. Press and hold the STO/CLR pushbutton. The following reading rates will scroll on the display:
 - $r = 0$ (3 rds/sec)
 - $r = 1$ (1 rdg/sec)

- $r = 2$ (1 rdg/10 sec)
- $r = 3$ (1 rdg/min)
- $r = 4$ (1 rdg/10 min)
- $r = 5$ (1 rdg/hr)
- $r = 6$ (1 rdg every time STO button is pressed)

NOTE

There is no need to select a rate if just minimum/maximum readings are desired. Momentarily press the STO/CLR button to start the store.

- B. Release the STO/CLR pushbutton when the desired reading rate is displayed. The STO annunciator will turn on and data will be stored at the selected rate.

NOTE

The data store cycle can be terminated at any time by doing the following:

- A. If in $r=6$ mode, press the RCL button and the STO/CLR button.
- B. If in any other r mode, only press the STO/CLR button.

With the data store off, data is retained and can be recalled at any time as long as the instrument remains on.

3. Data Retrieval: Data can be retrieved at any time, but a flashing RCL annunciator indicates that the maximum number of readings (100) have been stored.
 - A. Press and hold in the RCL pushbutton. The display will scroll through the data points and MIN/MAX (LO/HI). The first data point displayed will be the last stored reading. The next two data points will be the HI and LO readings made during that store cycle. Notice that the longer the RCL pushbutton is held in the faster the data points will scroll on the display.
 - B. Release the RCL pushbutton at the desired data point and note the reading (data) on the display. The data pointer can be incremented by steps of one by momentarily holding in the RCL pushbutton.
4. Shut off the data store by pressing the STO/CLR pushbutton. All stored data will be retained until a new store cycle has commenced.

2.8 MEASUREMENT CONSIDERATIONS

This section describes the effects of source resistance, capacitance, noise and leakage resistance on the measurement. Other measurement considerations are also discussed. Minimum and maximum values of these source parameters are defined, at which point a significant degradation of the measurement can begin to occur. Compensation methods are described to minimize these effects. Refer to Figure 2-3 for the following discussion.

2.8.1 Source Resistance

As shown in Table 2-2, a minimum value of source resistance is recommended for each range. The reason for this can be understood by examining Figure 2-3. Considering effects on low frequency noise and drift, C_S and C_{FB} can momentarily be ignored.

Input amplifier noise and drift appearing at the output can be calculated as follows:

Equation 1.

$$\text{Output } e_{\text{noise}} = \text{Input } e_{\text{noise}} \times \left(1 + \frac{R_{FB}}{R_S}\right)$$

Thus it is clear that as long as $R_S \gg R_{FB}$, Output $e_{\text{noise}} \cong$ Input e_{noise} . When $R_{FB} = R_S$, Output $e_{\text{noise}} = 2 \times$ Input e_{noise} .

The same applies for e_{OS} .

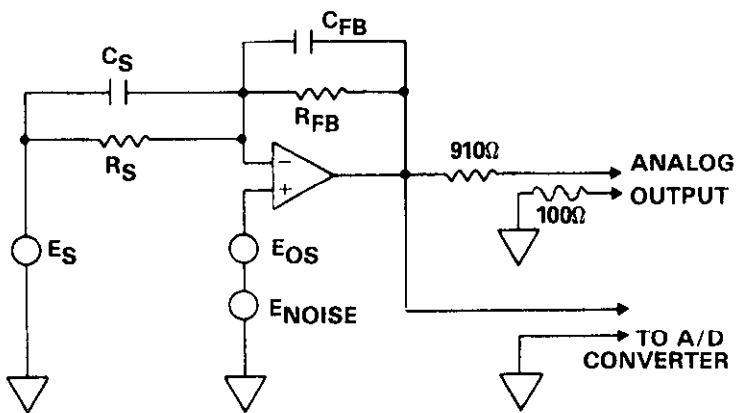

Figure 2-3. Simplified Model for Input Signal Conditioning

Model 485 will typically show insignificant degradation in displayed performance with the noise gain of 2 resulting from allowing $R_S = R_{FB}$. Typical amplifier input e_{noise} is about $5\mu\text{V}$ p-p in a bandwidth of 0.1-10Hz. Amplifier E_{OS} can be nulled with front panel ZERO adjustment, but available resolution limits this adjustment to about $5\mu\text{V}$. The temperature coefficient of E_{OS} is $< 20\mu\text{V}/^\circ\text{C}$. These numbers can be used with Equation (1) to determine expected displayed noise/drift given any source resistance. Remember that 1 displayed count = $100\mu\text{V}$ except on 2nA range where 1 displayed count = $10\mu\text{V}$. Note also that the values given in Table 2-2 for minimum source resistance also represent the value of R_{FB} on that range.

2.8.2 Source Capacitance

The Model 485 is designed to accommodate up to 10,000pF input capacitance (C_S). This limit will preclude problems in most test setups and allow extremely long input cable lengths without inducing instability or oscillations.

Increasing capacitance beyond this level may increase noise and induce instrument instability. The noise gain of the measurement circuit can be found from: Equation 2.

$$\text{Output } e_n = \text{Input } e_n \times \left(1 + \frac{Z_F}{Z_S}\right)$$

where $Z_F =$

$$\frac{R_{FB}}{\sqrt{(2\pi f R_{FB} C_{FB})^2 + 1}}$$

and $Z_S =$

$$\frac{R_S}{\sqrt{(2\pi f R_S C_S)^2 + 1}}$$

Clearly as $f \rightarrow 0$ equation (2) reduces to equation (1).

The frequency range in interest is 0.1Hz to 10Hz which is the noise bandwidth of the A/D converter. The value of C_F is 220pF for nA ranges and $0.01\mu\text{F}$ otherwise.

In general, as C_S becomes larger, the noise gain becomes larger. An application where C_S may be greater than 10,000pF is leakage measurement of capacitors. In this case Input e_n must include the effects of the voltage source (E_S) used to bias the capacitor. The Keithley Model 230 is recommended for this application.

When measuring leakage currents on capacitors larger than 10,000pF, stability and noise performance can be maintained by adding a resistor in series with the capacitor under test. The value of this resistor should be around $1\text{M}\Omega$. For large capacitor values ($> 1\mu\text{F}$), the value of the series limiting resistor can be made lower in order to improve settling times; however, values below $10\text{k}\Omega$ are not generally recommended.

This resistor is not critical in terms of tolerance or stability. Any carbon composition resistor will prove adequate.

A second-order advantage to using this limiting resistor is added protection to Model 485 in the event of capacitor failure.

2.8.3 Leakage Resistance

The effect of leakage currents should be considered when making small current measurements with high impedance sources. Leakage current and its effects can be minimized by using high resistance insulation in the test circuits and guarding. Since the Model 485 is a feedback picoammeter, it is effectively guarded at the input. The effect of leakage paths on the measurement can be further minimized by using a guarded test fixture as shown in Figure 2-4. In the configuration shown, the current through the component under test will not be shunted significantly by either leakage resistance path. If a high voltage supply is used to make high resistance leakage measurements, it is suggested that a series current

limiting resistor be used to prevent exceeding the maximum overload input limit of the Model 485 in the event the item under test is shorted.

2.8.4 Zero Time Stability

The typical zero time stability of the Model 485 is less than one count per week, exclusive of temperature effects.

2.8.5 Grounding Considerations

Input LO (outer ring of input connector) should be connected to a potential at the source which is within 30V RMS of power line ground of the Model 485 or the equipment near it. Connection to power line ground is not made internally in order to avoid possible ground loops.

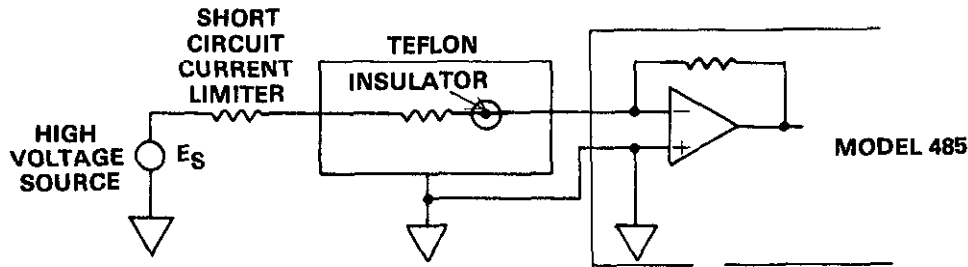

Figure 2-4. Test Fixture Guarding

2.9 APPLICATIONS

The following applications can be automated to various degrees with the use of programmable equipment over the IEEE-488 bus. The Model 485 becomes fully programmable with the addition of the Model 4853 interface. Programmable sources are available from Keithley and other manufacturers. The documentation that is provided with the Model 4853 includes example programs using various controllers.

The Model 485 may be used in conjunction with the Model 6104. The Model 6104 is a guarded and shielded test box for 2-terminal or 3-terminal connections. The Model 6104 provides excellent electrostatic shielding and high isolation resistance for the component under test. Clips plug into banana jacks allowing the user to fashion modified connections to suit the component to be tested.

The Model 6104 is useable with the Model 485 picoammeter and Keithley voltage supplies, such as the Model 230. When connected together as a system, using the cable and connector options, they form a complete test facility for measuring leakage current and other low current parameters for various test applications. A possible test set up is shown in Figure 2-5. The measurement sample would be connected between J1 and J7 or J8.

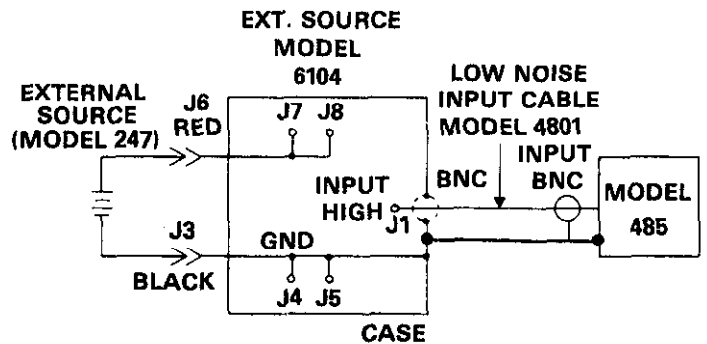

Figure 2-5. Leakage Test Set Up Using Model 6104

2.9.1 Op Amp Input Offset Currents

As the parameters of new BIFET, BIMOS, and FET op amps approach the parameters of the ideal op amp, such characteristics as the input offset current are breaking through the 1pA level. Use the Model 485 to measure these low level currents as shown in Figure 2-6. Note the connection of Model 485 input low.

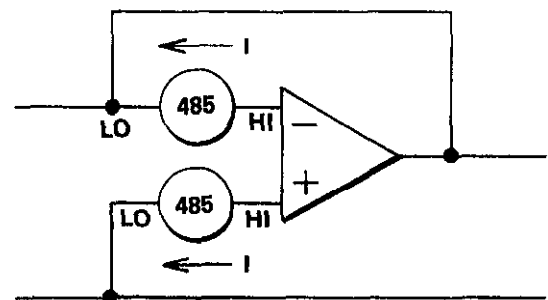

Figure 2-6. OP Amp Input Offset Currents Measurement

2.9.2 FET Gate Leakage and Channel Currents

Analog switches, multiplexer circuits, sample and hold circuits, integrators, LED drives, and many other circuits have errors generated by either gate leakage or channel leakage in FET-based components. For understanding the design limitations of a component or for tight component selection use the Model 485 as shown in Figure 2-7.

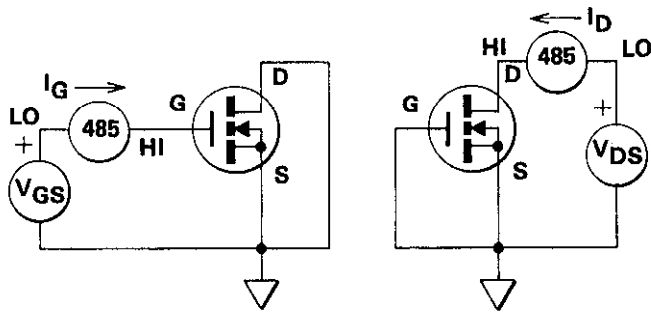

Figure 2-7. FET Gate Leakage and Channel Currents Measurement

2.9.3 Insulation Leakage Currents and High Resistance

In precise low power, low current circuitry, stray leakage currents can adversely affect circuit performance. Since leakage current is a non-linear function of voltage, the expected voltage level must be applied.

Leakage resistance of $10^{14}\Omega$ can be determined with the Model 485 and a voltage source of 100V. Using this tech-

nique, you can evaluate high resistance materials or insulation leakage of capacitors, PC boards, switches, or connectors under normal environmental conditions and under elevated temperature and humidity conditions. (see Figure 2-8).

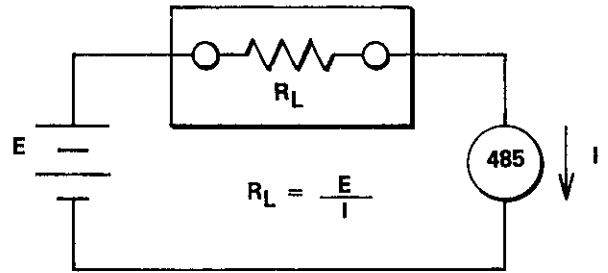

Figure 2-8. Insulation Leakage Currents and High Resistances Measurements

2.9.4 Phototube, Photodiode and Beam Currents

Photomultiplier tubes and other light detection devices require precise measurement of a wide range of currents (see Figure 2-9). Beam currents used for ion implantation, surface phenomena studies, and atomic structure analysis using scanning electron microscopy are in the picoamp to nanoamp range. The Model 485 has the accuracy and sensitivity to make these measurements with routine ease. In addition, for these applications it is convenient to cancel out dark currents, using the Model 485's "REL" feature. To present data in a logarithm format, simply touch the "LOG" button. Use the AUTO ranging feature to cover a broad dynamic range.

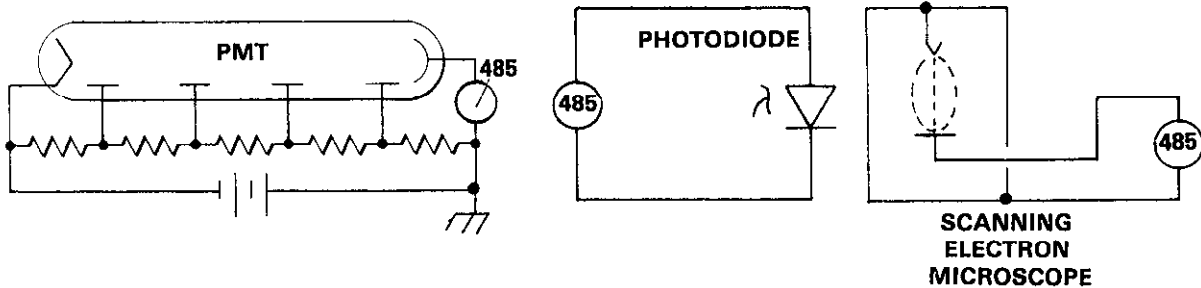

Figure 2-9. Setup to Measure Photomultiplier, Photodiode and Beam Currents

2.9.5 Resistivity Tests

The Model 485 may be used along with the Model 6105 to perform resistivity tests. The Model 6105 is a guarded test fixture for measurement of surface and volume resistivities. The chamber is designed in accordance with ASTM Standard Method of Test Electrical Resistance of Insulating Materials, D257-66. The Model 6105 can be used in conjunction with the Model 485 and a high voltage power supply, such as the Model 247.

Resistivity can be determined by measuring the current through a sample with a known voltage impressed. The Model 6105 can accommodate non-rigid sheet samples 2½ inches (63mm) to four inches (102mm) in diameter and ¼ inch (6mm) thick with excitation voltages up to 1000V. The Model 6105 has a UHF connector for the bias supply and a BNC output to the Model 485. A test hook up using the Model 247 power supply is shown in Figure 2-10.

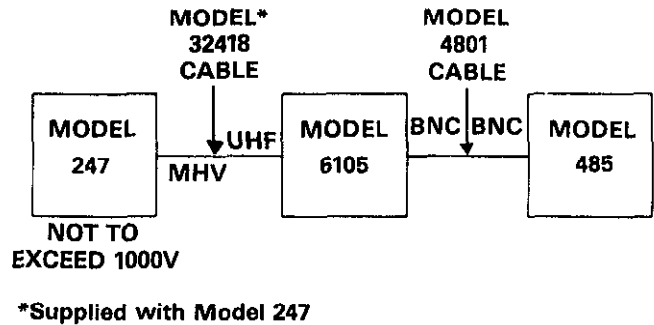

Figure 2-10. Resistivity Test Set Up

SECTION 3 PERFORMANCE VERIFICATION

3.1 INTRODUCTION

This section contains information necessary to verify that the Model 485 performance is within specified accuracy. Model 485 specifications may be found at the front of this manual. Ideally, performance verification should be performed when the instrument is first received to ensure that no damage or change in calibration has occurred during shipment. The verification procedure may also be performed whenever instrument accuracy is suspect or following calibration. If performance on any of the ranges is outside specified limits, calibration can be performed as described in Section 5.

NOTE

If the instrument does not meet specifications and it is still under warranty (less than 12 months since date of shipment), contact your Keithley representative or the factory to determine the action to be taken.

3.2 ENVIRONMENTAL CONDITIONS

All measurements should be made at an ambient temperature between 18° and 28°C (65° to 82°F) with a relative humidity less than 70%.

3.3 RECOMMENDED TEST EQUIPMENT

Equipment for verifying the performance of the Model 485 is listed in Table 3-1. Alternate equipment may be used as long as the equipment accuracy is at least as good as the specifications listed in Table 3-1. Information needed to build the test fixture can be found in Figure 3-1.

3.4 INITIAL CONDITIONS

Before performing the verification procedures, make sure the Model 485 meets the following conditions:

1. If the instrument has been subject to temperatures below 18°C (65°F) or above 28°C (82°F), allow sufficient time for the instrument to reach temperatures within the range. Generally, it takes one hour to stabilize an instrument that is 10°C (18°F) outside of this range.
2. Turn on the Model 485 and allow it to warm up one hour. The instrument may be operated from either line power or

battery pack power, as long as the battery pack has been fully charged as described in paragraph 2.2.3.

3.5 VERIFICATION PROCEDURE

The following paragraphs give the basic verification procedure for checking accuracy.

To properly check the accuracy of the Model 485, precision current sources are necessary. These precise currents are obtained by using the DC calibrator and measured resistors in a shielded test fixture, as shown in Figure 3-1.

Proceed as follows to check the accuracy of the Model 485:

NOTE

Record the following measurements and calculations in Table 3-2. Use a pencil so that the table can be reused.

1. Using the Keithley Model 191 or 192, measure and record the resistance of the 10kΩ, 100kΩ, 1MΩ and 10MΩ resistors.
2. Using the Guildline Model 9520, measure and record the resistance of the 100MΩ, 1GΩ and 10GΩ resistors.
3. Calculate and record the required DC calibrator setting for each range as follows:
DC Calibrator Setting: $V = I (\text{Required Current}) \times R (\text{Measured Resistor})$
4. Depress ZERO CHECK and select the 2nA range.
5. With an open input, adjust the ZERO pot for .0000 ± 1 count on the display.
6. Set the Model 485 to the appropriate range.
7. Connect the DC calibrator to the test fixture.
8. Connect the test fixture to the input of the Model 485 using a low-noise coaxial input cable, such as the Keithley Model 4801.
9. Using Table 3-2 as a guide, install the appropriate resistor in the test fixture, set the DC calibrator to the calculated setting and check all the ranges of the Model 485.
10. Reverse the + and - test leads at the DC calibrator and repeat all checks with negative current.

Table 3-1. Recommended Test Equipment

Description	Specification	Mfr.	Model
DC Calibrator	19V; ±0.002%	Fluke	343A
Resistor	10GΩ; ±2%	Keithley	R-319-10G
Resistor	1GΩ; ±2%	Keithley	R-289-1G
Resistor	100MΩ; ±1%	Keithley	R-289-100M
Resistor	10MΩ; ±0.1%	Keithley	R-299-10M
Resistor	1MΩ; ±0.1%	Keithley	R-299-1M
Resistor	100kΩ; ±0.1%	Keithley	R-298-100k
Resistor	10kΩ; ±0.1%	Keithley	R-298-10k
DMM	20kΩ-20MΩ; ±0.08%	Keithley	191 or 192
Teraohmmeter	100MΩ; ±0.035%	Guidline	9520
	1GΩ; ±0.05%		
	10GΩ; ±0.07%		
Shielded Test Fixture	(see Figure 3-1)	—	—

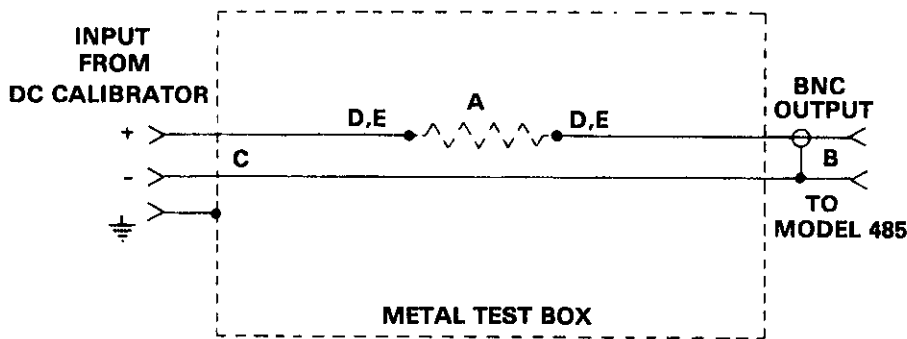

PARTS LIST

A = Resistor:

- 10GΩ for 2nA range, Keithley P/N R-319-10G
- 1GΩ for 20nA range, Keithley P/N R-289-1G
- 100MΩ for 200nA range, Keithley P/N R-289-100M
- 10MΩ for 2μA range, Keithley P/N R-299-10M
- 1MΩ for 20μA range, Keithley P/N R-299-1M
- 100kΩ for 200μA range, Keithley P/N R-298-100kΩ
- 10kΩ for 2mA range, Keithley P/N R-298-10k

B = One BNC connector, Keithley P/N CS-44

C = Three banana jacks, Keithley P/N's BP-11-0, BP-11-2, BP-11-5

D = Two banana jacks, Keithley P/N BJ-3

E = Two test clips, Keithley P/N BP-9

Figure 3-1. Shielded Test Fixture

Table 3-2. Range Accuracy

485 Range	Required Current (I)	Required Resistor	Required Voltage (Approx)	Measured Value of Resistor (R)	Calculated* DC Calibrator Setting (V)	Allowable Readings (18°C -28°C)
2 nA	1.9000nA	10GΩ	19V	_____	_____	1.8920 to 1.9080
20 nA	19.000nA	1GΩ	19V	_____	_____	18.923 to 19.077
200 nA	190.00nA	100MΩ	19V	_____	_____	189.61 to 190.39
2 μA	1.9000 μA	10MΩ	19V	_____	_____	1.8971 to 1.9029
20 μA	19.000 μA	1MΩ	19V	_____	_____	18.980 to 19.020
200 μA	190.00μA	100 kΩ	19V	_____	_____	189.80 to 190.20
2mA	1.9000mA	10 kΩ	19V	_____	_____	1.8980 to 1.9020

*V = (I) (R)

where:

V = Calibrator Setting

I = Required Current

R = Measured Value of Resistor

SECTION 4 THEORY OF OPERATION

4.1 INTRODUCTION

This section contains an overall functional description of the Model 485. Information pertaining to the Model 1758 Battery Pack option is also included. Detailed schematics and component layout drawings are located at the end of this instruction manual.

4.2 OVERALL FUNCTIONAL DESCRIPTION

Basically the Model 485 is a $4\frac{1}{2}$ digit $\pm 20,000$ count autoranging picoammeter with seven DC current ranges. A simplified block diagram of the Model 485 is shown in Figure 4-1. The heart of the Model 485 is a transresistance amplifier (current-to-voltage converter) followed by an A/D converter that translates the conditioned analog input signals into a form useable by the microcomputer.

4.3 ANALOG CIRCUITRY

The following paragraphs contain a description of the current-to-voltage converter, multiplexer, buffer amplifier, -2V reference and A/D converter circuits. These circuits may be found on schematic diagram number 485-106 located at the end of this manual.

4.3.1 Current-to-Voltage Converter (Transresistance Amplifier)

The current-to-voltage converter is shown in simplified form in Figure 4-2. Operational amplifier U105 is connected as a feedback x1 amplifier with selectable feedback resistors. In this configuration, the linear transfer function of U105 is $-(I_{IN})R = V_O$. On all but the 2nA range, the feedback resistance is selected such that a full scale current input will

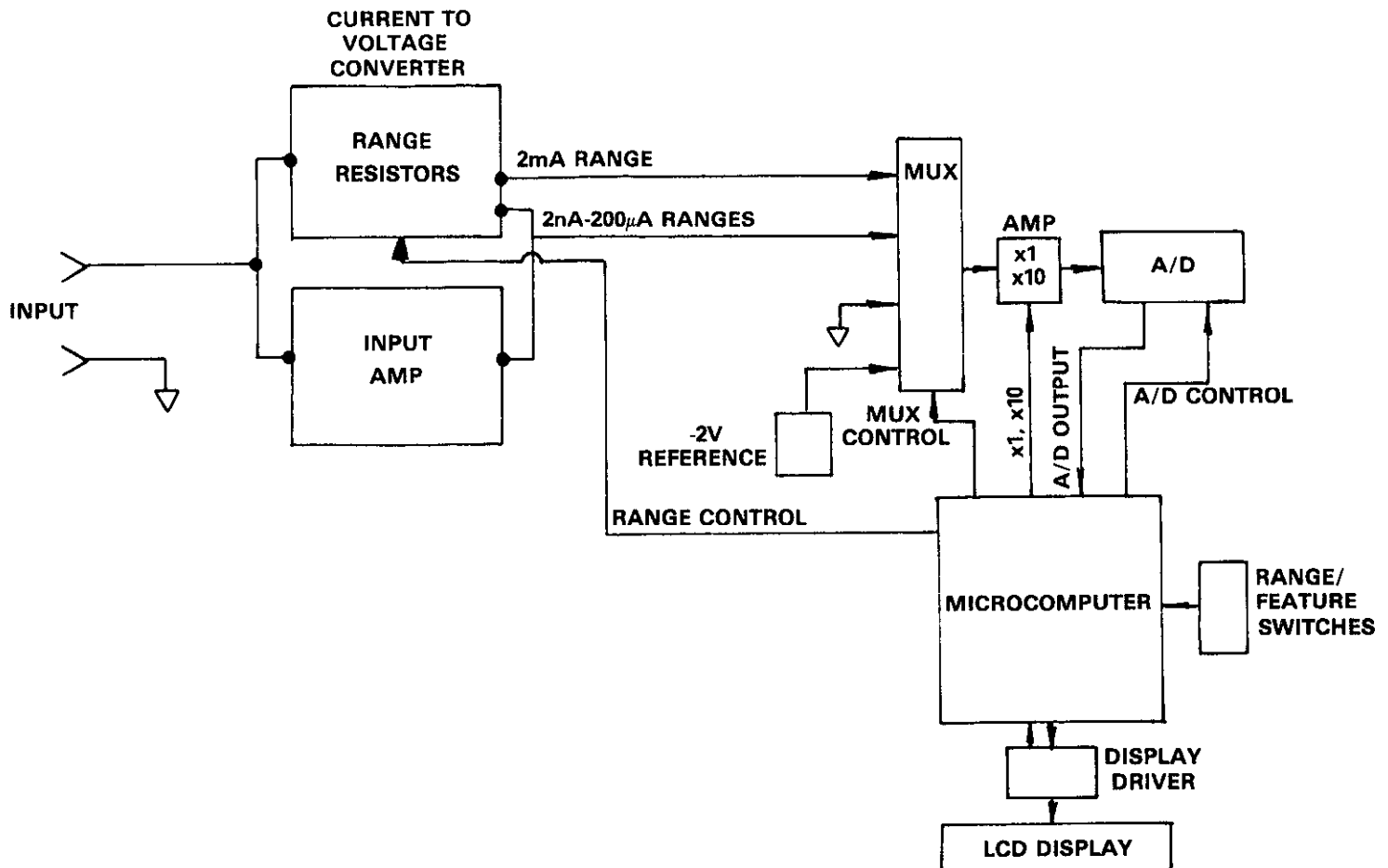

Figure 4-1. Simplified Block Diagram

result in a 2V output from the converter $[-(2\text{mA}) \times 1\text{k}\Omega = -2\text{V}]$. On the 2nA range, the fullscale output is 200mV $[-2\text{nA}(\times 100\text{M}\Omega) = -200\text{mV}]$. The maximum output voltage from the converter for an on-scale reading is $\pm 1.9999\text{V}$ ($\pm 199.99\text{mV}$ for the 2nA range).

Actuating the ZERO CHECK pushbutton shorts the feedback resistance of U105 which results in the offset of U105 being presented at its output. The ZERO pot is used to eliminate the offset of the amplifier.

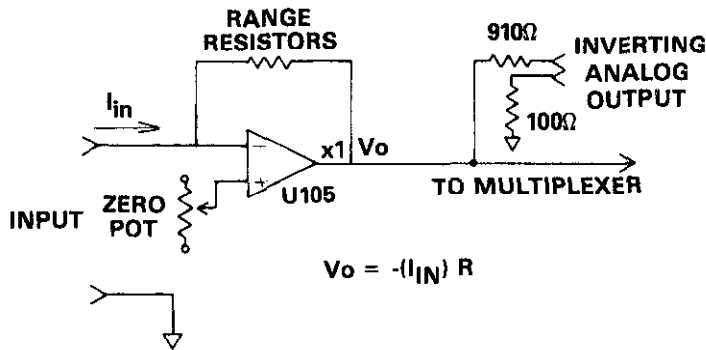

Figure 4-2. Current-to-Voltage Converter

4.3.2 Multiplexer

The multiplexer connects one of four signals to the buffer amplifier; two possible signal lines, zero or the reference. The multiplexer, shown in Figure 4-3, is made up of 4 JFETs which are controlled by the microprocessor through U111. The FETs are driven by U102 and part of U103. The drivers convert the digital signals of the microprocessor to signals useable by the FETs.

All ranges, except the 2mA range, are fed to Q106 of the multiplexer. The 2mA range uses a line that senses the signal before the range FET (Q101) and feeds it directly to the multiplexer (Q105). The sense line is needed because of the relatively high resistance of the range FET (60Ω) as compared to the resistance of the feedback resistor ($1\text{k}\Omega$).

Ordinarily, FET switching creates transients which could be seen in the final measurement. These effects are minimized in the Model 485 through the use of software generated delays and by signal-ground differential measurements.

4.3.3 Input Buffer Amplifier

The input buffer amplifier provides the necessary isolation between the input signal and the A/D converter. The amplifier is a noninverting, low noise, high impedance circuit with x1 gain for the 20nA-2mA ranges and x10 gain for the 2nA range. The amplifier gain is controlled by the microprocessor. Figure 4-4 shows the simplified schematic of the input buffer amplifier.

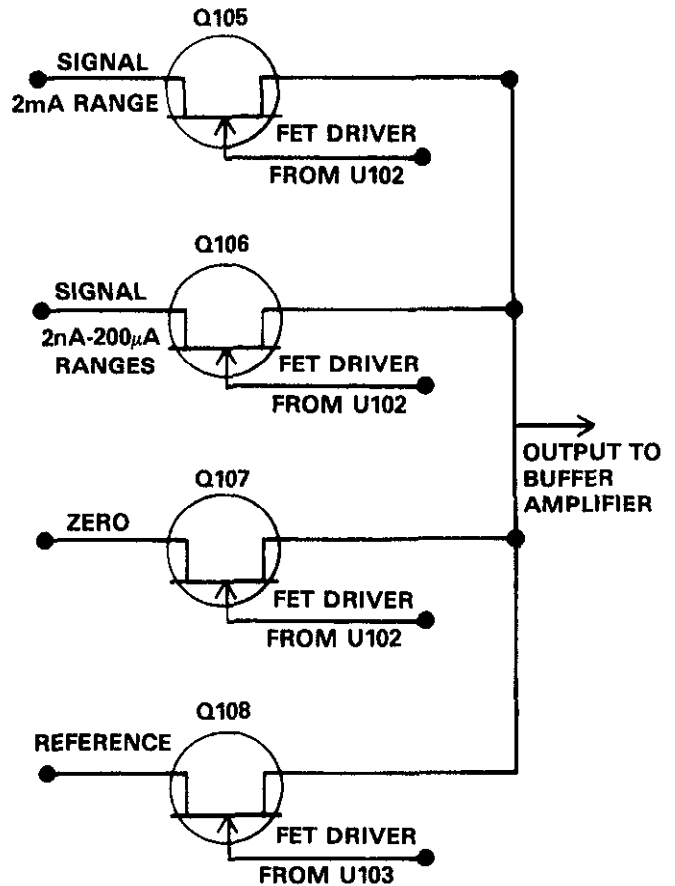

Figure 4-3. Simplified Schematic of the Multiplexer

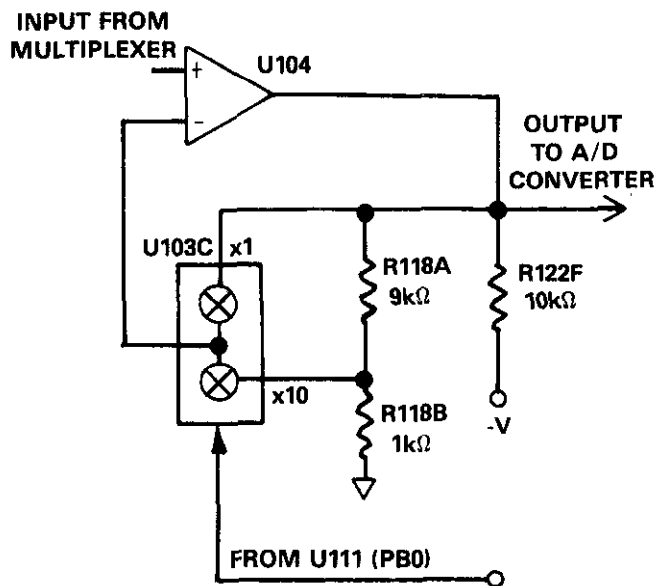

Figure 4-4. Simplified Schematic of the Input Buffer Amplifier

4.3.4 -2V Reference Source

The Model 485 current measurements are based on comparing the unknown signal with an internal -2V reference voltage. During each measurement cycle the microprocessor samples the unknown and uses it along with a zero measurement and -2V signal measurement to compute the unknown voltage.

The -2V reference is made up of a highly stable zener diode (VR103), an op-amp and a resistive voltage divider. U107 and R122 A, B, C act as a constant current source to minimize the zener voltage variations. R118 C, D is then used to divide down the -6.35V zener voltage to approximately -2V.

The output of U107 (-7V) is used as a reference voltage for the A/D converter and as a negative supply for various components.

4.3.5 A/D Converter

The Model 485 uses a combination constant frequency charge balance, single slope analog-to-digital converter. A simplified schematic of the A/D used in the Model 485 is shown in Figure 4-5 with an associated output waveform.

The charge balance phase begins when the input enable line is set high. This occurs at the end of a software-generated delay period that allows the signal to settle after the ap-

propriate multiplexer FET is turned on. The actual delay period depends on the selected range and function.

Once this occurs the signal from the buffer amplifier is added to the offset from R122H. This converts the bipolar signal from the buffer ($\pm 2V$) to a unipolar input for the integrator.

The integrator ramps up until it just passes the charge-balance comparator threshold voltage. When the rising edge of Q3 occurs from U116 or when U115 goes low, \bar{Q} goes high forcing I_{CB} into the integrator input. Since I_{CB} is much greater than the current through R122G and R122H the integrator output voltage will ramp in the negative direction. The integrator will continue ramping downward until U115B goes low. Each time the output U117A goes high it is gated (inside the microprocessor) with the microprocessor's internal clock and these pulses are counted. Once U117A goes low the process repeats itself.

The charge balance phase continues for 100msec. At the end of the charge balance phase, the output of the integrator is resting at some positive voltage. Since the integrator output is connected to the noninverting input of the U110A, its output will stay high until the integrator ramps negative. During single slope Q109 is turned off and R120H is connected to +5V. The single slope comparator is then gated with the microprocessor's internal clock and counted. Once the comparator output goes low the microprocessor stops counting and can compute the reading.

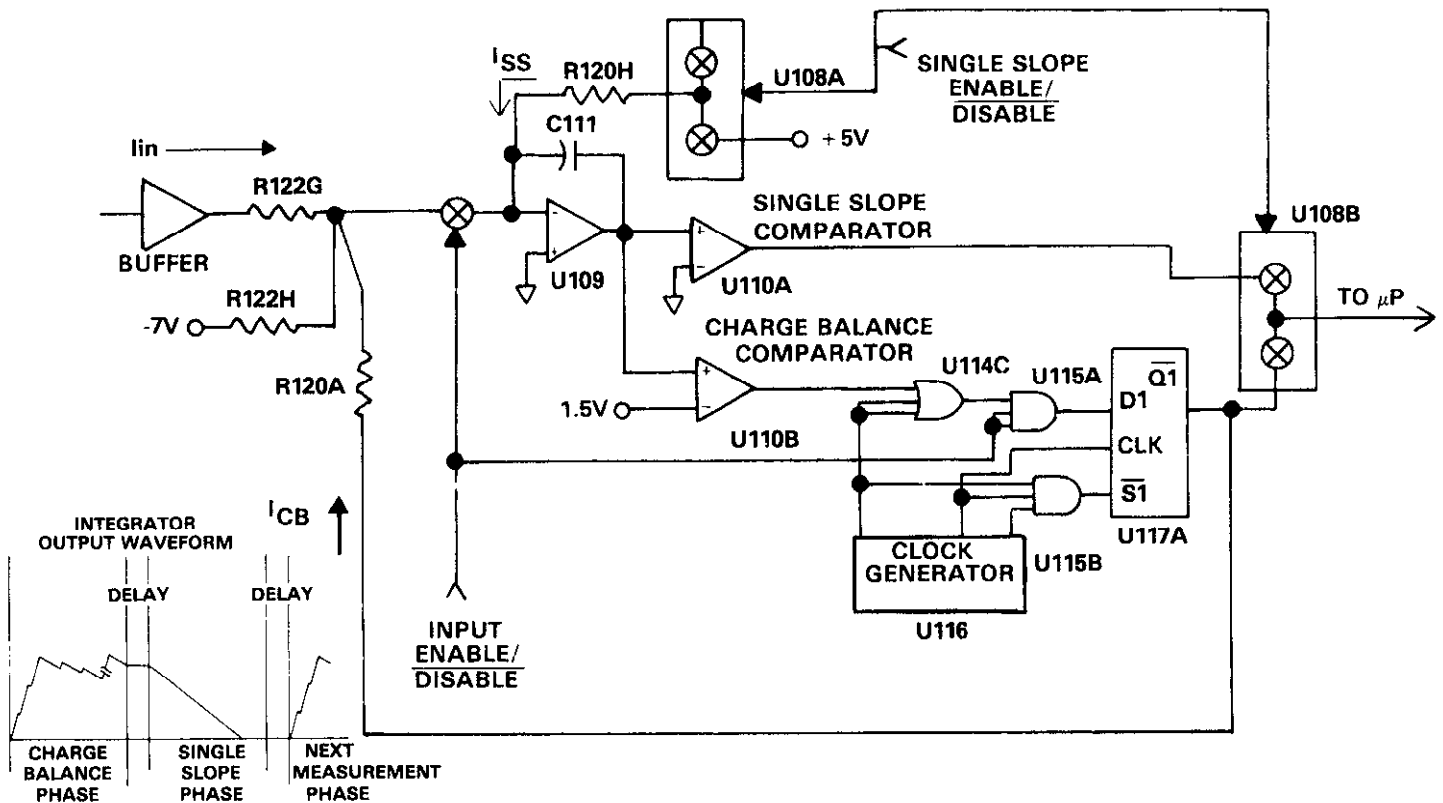

Figure 4-5. A/D Converter

4.4 DIGITAL CIRCUITRY

Model 485 operation is controlled by the internal microcomputer. This section briefly describes the operation of the various sections of the microcomputer and associated digital circuitry. For complete circuit details refer to schematic diagram number 485-106 at the end of this manual.

4.4.1 Microcomputer

The microcomputer (MPU) centers around the 146805E2 CMOS microprocessor. It is an 8 bit microprocessor with direct addressing of up to 8k bytes on a shared address and data bus.

Timing of the microprocessor is accomplished by the use of Y101; a 3.2768MHz crystal. Internally this frequency is divided down by 5 to obtain a bus operating frequency of 655.36kHz. This is present on the address strobe of U120 (pin 6) and supplies timing to all other parts of the instrument through the binary divider U116.

The software for the MPU is stored in U113 (PROM). Temporary storage is provided by U112. U112 is used to store the calibration constants on power up and as RAM for the microprocessor's in-house functions. It also stores readings for the data logger. U123 is the NVRAM and is used to store the calibration constants which are moved to the RAM (U112) on power up.

4.4.2 Address Decoding

U119 is used to latch in the address that is on the bus when the address strobe of U120 goes high and presents it to the PROM (U113) during data strobe.

4.4.3 PIA

U111 provides for most of the control of the instrument. It controls all ranging hardware, A/D converter, and data output and input for the IEEE option.

4.4.4 Display Board

The LCD display is driven by a flat pack LCD controller chip U201 and it communicates to the microprocessor through four control lines. During power-up the microprocessor configures U201 to drive the triplexed display.

In order to drive the display correctly four voltages are obtained from R121. The clock required by U201 is obtained from U116.

The display board also houses the special function keys; LOG, REL, STO/CLR and RCL.

4.5 DIGITAL CALIBRATION

The Model 485 uses digital calibration to eliminate calibration potentiometers in the instrument. The constants that the Model 485 uses are stored in a nonvolatile electrically alterable read only memory (U123), and are read on power-up of the instrument. There is one constant for each range.

4.6 POWER SUPPLY

Fuse F101 is the LINE FUSE which is internally accessible. S101 is the power ON/OFF switch, and S102 selects 115V or 230V operations by placing the transformer primary windings in parallel or series.

T101, the power transformer has two secondary windings; one for the Model 485 and the other for the IEEE option (Model 4853). The bridge rectifier (CR101) functions as a fullwave rectifier for both the plus and minus supplies. R125 limits current to the 12V zener (VR106) and to the batteries (if installed) for charging. The zener acts as a pre-regulator to the +5V regulator.

4.7 MODEL 1758 BATTERY OPTION

Maximum battery charging rate is achieved when the instrument is connected to line power and the ON/OFF switch is off. Fullwave rectified voltage from CR101 is applied to R102 and BT101 to charge the batteries. Q101 acts as a current sink if the charging current rises above 150mA. The batteries are of the quick recharge type and will charge in 8 to 10 hours. With the instrument turned on the batteries will trickle charge at approximately 40mA.

With the battery pack installed, the negative supply is generated using a CMOS voltage inverter (U101). The output of the inverter is applied to CR101 and C101 for filtering.

Low battery detection is accomplished by the comparator (U102) and the microprocessor. A voltage level of 8.8V across BT101 signals the end of useful battery life. The trip level for the comparator is set by R103 and R104.

SECTION 5 MAINTENANCE

5.1 INTRODUCTION

This section contains installation, calibration and service information for the Model 485 and 1758 Battery Pack.

WARNING

The procedures described in this section are for use only by qualified service personnel. Do not perform these procedures unless qualified to do so. Many of the steps covered in this section may expose the individual to potentially lethal voltages that could result in personal injury or death if normal safety precautions are not observed.

5.2 TOP COVER REMOVAL/INSTALLATION

The top cover of the Model 485 must be removed in order to move the calibration jumper, service the unit or to install the Model 1758 battery pack and/or the Model 4853 IEEE-488 interface. Proceed as follows:

WARNING

Service by qualified personnel only. Disconnect the line cord and all other sources and cables before removing the top cover.

1. Turn off the power, disconnect the line cord and remove all test leads from the terminals of the Model 485.
2. Turn the unit over and remove the four screws from the bottom of the case.
3. Turn the unit over again and separate the top cover from the rest of the unit.
4. To reinstall the top cover, position the tilt bail properly into the bottom cover and reverse the above procedure.

5.3 BATTERY PACK INSTALLATION

Refer to Figure 6-1 and perform the following procedure to install the battery pack:

WARNING

Service by qualified personnel only. Disconnect line cord and remove all test leads from the terminals of the Model 485.

1. Remove the top cover as explained in paragraph 5.2.
2. Remove the four screws securing the shield to the mother board.
3. Position the battery board as shown in Figure 6-1 and secure it to the shield using two supplied screws. The

screws are fed through the shield into the battery board fasteners.

4. Place the battery pack in the bracket and position it on the shield as shown. Feed the two screws through the shield into the bracket and tighten.

CAUTION

Do not allow the battery leads to short together or damage to the batteries may occur.

5. Carefully place the shield (with battery pack) back into the Model 485 and replace the four screws securing it.
6. Connect the ribbon cable from the battery board to the male connector (marked BAT) on the mother board.

CAUTION

Make a close visual inspection to ensure that the connector is properly mated or damage to the instrument may result.

7. Connect the red battery lead to the + RED terminal pin on the battery board. Connect the black battery lead to the -BLK terminal pin on the battery board.
8. Reinstall the top cover as explained in paragraph 5.2.
9. Charge the battery pack per instructions in paragraph 2.2.3.

NOTE

The IEEE interface (Model 4853) cannot be used on battery power.

5.4 FRONT PANEL CALIBRATION

Calibration should be performed every 12 months, or if the performance verification procedures in Section 3 show that the Model 485 is out of specification. If any of the calibration procedures in this section cannot be performed properly, refer to the troubleshooting information in this section. If the problem persists, contact your Keithley representative or the factory for further information.

The entire calibration procedure may be performed without having to make any internal adjustments.

5.4.1 Recommended Calibration Equipment

The same equipment that is used in the performance verification procedure is used to calibrate the Model 485. This equipment is listed in Table 3-1. The information needed to build the shielded test fixture is provided in Figure 3-1.

5.4.2 Calibration Storage Enable

The CAL LOCK switch of the Model 485 must be in the calibration storage enable position in order to store calibration constants into NVRAM. If the switch is not placed in the enabled position, calibration will be lost when the instrument is turned off.

The access hole for the CAL LOCK switch is located to the left of the ON/OFF power switch. CAL LOCK is a two position (IN and OUT) pushbutton switch. To enable calibration storage, insert a small-bladed screwdriver into the access hole in the front panel and set the pushbutton switch to the innermost position.

5.4.3 Environmental Conditions

Calibration should be performed under laboratory conditions having an ambient temperature of $23 \pm 3^\circ\text{C}$ and a relative humidity of less than 70%. With the instrument on, allow it to warm up for one hour. If the instrument has been subjected to temperatures outside this range, or to higher humidity, allow at least one additional hour for the instrument to stabilize before beginning the calibration procedure.

NOTE

Calibration can be stopped at any time and only selected ranges can be calibrated if needed.

5.4.4 Calibration Procedure

Perform the following steps to calibrate the Model 485:

NOTE

Record the following measurements and calculations in Table 5-1. Use a pencil so that the table can be used again.

1. Using the Keithley Model 191 or 192, measure and record the resistance of the $10\text{k}\Omega$, $100\text{k}\Omega$, $1\text{M}\Omega$ and $10\text{M}\Omega$ resistors.
2. Using the Guildline Model 9520, measure and record the resistance of the $100\text{M}\Omega$, $1\text{G}\Omega$ and $10\text{G}\Omega$ resistors.
3. Calculate and record the required DC calibrator setting for each range as follows (Refer to Table 5-1):
 $V = I (\text{Required Current}) \times R (\text{Measured Resistor})$
4. Depress ZERO CHECK and select the 2nA range.
5. With an open input, adjust the ZERO pot for $.0000 \pm 1$ count on the display.

NOTE

If Q104, U105, R113, R114 or R115 were changed, the instrument may not zero. See paragraph 5.7 for instructions on balancing the input amplifier offset.

6. Connect the DC calibrator to the test fixture. Make sure that the calibrator is in standby.
7. Connect the test fixture to the input of the Model 485 using a low-noise coaxial input cable (such as the Keithley Model 4801).
8. Press in the REL and LOG pushbuttons simultaneously until the message "CAL" is displayed. Release the buttons. The unit is now in the calibration mode as indicated by the "CAL" annunciator.
9. With the Model 485 in the calibration mode, perform the following procedure using Table 5-1 as a guide.
 - A. With the DC calibrator in standby, install the appropriate resistor in the test fixture.
 - B. Set the Model 485 to the appropriate range.
 - C. Set the DC calibrator to output the calculated voltage level needed to generate the required current.
 - D. Adjust the display accordingly with the use of the STO/CLR and RCL buttons. The STO/CLR button increments the displayed reading and the RCL button decrements the displayed reading.

5.4.5 Calibration Storage

To store the calibration constants, simultaneously press REL and LOG until the message "stor" is displayed. The instrument will return to normal operation.

If however, the message "out" is displayed, the CAL LOCK switch is in the disable (OUT) position. The CAL annunciator on the display will blink indicating that calibration is temporary and will be lost when the instrument is turned off.

NOTE

If calibration was inadvertently performed with CAL LOCK in the disable (OUT) position, calibration constants can be stored by performing the following steps:

1. Place the CAL LOCK switch to the enable (IN) position (see paragraph 5.4.2).
2. Simultaneously press REL and LOG until "CAL" is displayed. This places the instrument back into the calibration mode.
3. Simultaneously press REL and LOG until "stor" is displayed.

Table 5-1. Range Calibration

485 Range	Required Current (I)	Required Resistor	Required Voltage (Approx)	Measured Value of Resistor (R)	Calculated* DC Calibrator Setting (V)	485 Reading
2 nA	1.9000nA	10GΩ	19V	_____	_____	1.9000
20 nA	19.000nA	1GΩ	19V	_____	_____	19.000
200 nA	190.00nA	100MΩ	19V	_____	_____	190.00
2 μA	1.9000μA	10MΩ	19V	_____	_____	1.9000
20 μA	19.000μA	1MΩ	19V	_____	_____	19.000
200 μA	190.00μA	100 kΩ	19V	_____	_____	190.00
2mA	1.9000mA	10 kΩ	19V	_____	_____	19000

*V = (I) (R)

where:

V = Calibrator Setting

I = Required Current

R = Measured Value of Resistor

5.5 CALIBRATION OVER IEEE-488 BUS

The calibration procedure can be automated by using programmable equipment over the IEEE-488 bus. The Model 485 becomes fully programmable with the addition of the Model 4853 interface. Programmable sources are available from Keithley and other manufacturers. The documentation that is provided with the Model 4853 includes example programs using various controllers.

5.6 TROUBLESHOOTING

The troubleshooting instructions contained in this section are intended for qualified personnel having a basic understanding of analog and digital circuitry. The individual should also be experienced at using test equipment as well as ordinary troubleshooting procedures. The information presented here has been written to assist in isolating a defective circuit or circuit section; isolation of the specific component is left to the technician.

NOTE

Avoid touching the PC board or its component parts. Handle the PC board by its edge.

5.6.1 Recommended Test Equipment

The success or failure in troubleshooting the Model 485 depends not only on the skill of the technician, but also relies heavily on accurate, reliable test equipment. Table 5-2 lists the equipment and specifications recommended for troubleshooting the Model 485. Other equipment such as logic analyzers, capacitance meters, etc, could also be helpful in difficult situations.

5.6.2 Self Diagnostic Program

To use the self diagnostic program, hold in the LOG button and turn on the Model 485. The following will occur:

1. All LCD digits and annunciators will turn on.
2. The software revision level will be displayed (i.e. A1).
3. The sequential display test will run.
4. The Model 485 will go into the troubleshooting test mode.

If the LOG button is released the instrument will flag either RAM or NVRAM self test failures, should they occur. If neither RAM nor NVRAM fails, the instrument will default to the troubleshooting test mode.

Table 5-2. Recommended Troubleshooting Equipment

MFG	Description	Use
Keithley Model 175	Five-function DMM with 0.05% basic DC accuracy, 10MΩ input impedance	Power supply and DC voltage checks, analog signal tracing, continuity, static logic levels.
Tektronix Model 2213	Dual-trace, triggered-sweep oscilloscope, DC to 60MHz bandwidth.	Digital and analog waveform checks.

RAM Test—If the RAM test fails, the Model 485 will lock up with all zeroes displayed. Replacing U112 may correct problem.

Non-Volatile RAM Test—If the NVRAM test fails, the following message will be displayed.

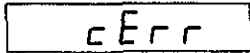

This is a sufficient message indicating that the instrument is probably not properly calibrated since calibration constants are stored in the non-volatile RAM. The Model 485 will lock up at this point if the test fails, but operation may be restored for troubleshooting by pressing any front panel momentary button. The flashing "CAL" annunciator will indicate that the unit failed the NVRAM test.

At this point try calibrating the instrument with the constants already entered by simultaneously pressing in the REL and LOG buttons until "CAL" is displayed, and then again until "Stor" is displayed. If error gets corrected, indicating that the NVRAM is probably good, a full calibration will be needed. If the error persists try replacing the NVRAM chip (U123). Again, the Model 485 must undergo a complete calibration after the problem is corrected.

Sequential Display Test—Segments and annunciators are sequentially displayed in eight steps. Use Figure 5-1 for segment identification. The steps are as follows:

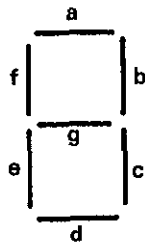

Figure 5-1. Segment Identification

1. The "a" segments of the digits, and the LOG and CAL annunciators are displayed.
2. The "b" segments of the digits are displayed.
3. The "c" segments of the digits are displayed.
4. The "d" segments of the digits, and the m, ZERO CHECK and RMT annunciators are displayed.
5. The "e" segments of the digits, minus sign and the REL, and A annunciators are displayed.
6. The "f" segments of the digits, and the AUTO and BAT annunciators are displayed.
7. The "g" segments of the digits, and the RCL and n annunciators are displayed.
8. The decimal points, most significant digit and the STO and A annunciators are displayed.

Troubleshooting Test Modes—The troubleshooting mode is designed to switch on various switching FETs, relays and logic levels to allow signal tracing through the instrument. The first displayed mode will reflect the function and range. For example, assume that "0A1" is displayed. The "1" corresponds to the 2nA range, and the "0" is the test number. The test number can be changed by pressing in the LOG button. Table 5-3 lists the test modes for all ranges.

To update the test mode, select the new range and hold in the LOG button until range number changes.

Troubleshooting consists of selecting the desired test mode and using the data found in Table 5-3 to signal trace the circuit.

NOTES:

1. When a different range is selected the LOG button must be pressed and held in to update the display with the corresponding test mode.
2. Do not use AUTO or ZERO CHECK in the self-diagnostic mode.
3. To get out of the self-diagnostic mode, cycle power.

Table 5-3. Troubleshooting Modes

Range	Test Mode	Range Relay Closed (Note 1)	Range FET On (Note 2)	Multiplexer FET On (Note 3)	Amplifier Gain (U104) (Note 4)	Range Control Logic Levels On U111 (Note 5)				
						PA0	PA1	PA2	PA3	PB1
2 nA	0A1	none	none	Q106	x10	1	0	0	0	1
	1A1	none	none	Q107	x10	1	0	0	0	1
	2A1	none	none	Q108	x1	1	0	0	0	1
	3A1	none	none	Q107	x1	1	0	0	0	1
20 nA	0A2	none	none	Q106	x1	1	0	0	0	1
	1A2	none	none	Q107	x1	1	0	0	0	1
	2A2	none	none	Q108	x1	1	0	0	0	1
	3A2	none	none	Q107	x1	1	0	0	0	1
200 nA	0A3	K102	none	Q106	x1	1	0	0	0	0
	1A3	K102	none	Q107	x1	1	0	0	0	0
	2A3	K102	none	Q108	x1	1	0	0	0	0
	3A3	K102	none	Q107	x1	1	0	0	0	0
2 μ A	0A4	K102	Q103	Q106	x1	1	0	0	1	0
	1A4	K102	Q103	Q107	x1	1	0	0	1	0
	2A4	K102	Q103	Q108	x1	1	0	0	1	0
	3A4	K102	Q103	Q107	x1	1	0	0	1	0
20 μ A	0A5	K101	none	Q106	x1	0	0	0	0	1
	1A5	K101	none	Q107	x1	0	0	0	0	1
	2A5	K101	none	Q108	x1	0	0	0	0	1
	3A5	K101	none	Q107	x1	0	0	0	0	1
200 μ A	0A6	K101	Q102	Q106	x1	0	0	1	0	1
	1A6	K101	Q102	Q107	x1	0	0	1	0	1
	2A6	K101	Q102	Q108	x1	0	0	1	0	1
	3A6	K101	Q102	Q107	x1	0	0	1	0	1
2mA	0A7	K101	Q101	Q105	x1	0	1	0	0	1
	1A7	K101	Q101	Q107	x1	0	1	0	0	1
	2A7	K101	Q101	Q108	x1	0	1	0	0	1
	3A7	K101	Q101	Q107	x1	0	1	0	0	1

- NOTES: 1. Range relays are K101 and K102.
 2. Range FETs (Q101, Q102 and Q103) are turned off by -7V on gates.
 3. Multiplexer FETs (Q105, Q106, Q107 and Q108) are turned off by -7V on gates.
 4. +5V on pin 9 of U103C selects x10 gain. 0V selects x1 gain.
 5. Logic level 1 = 5V. Logic level 0 = 0V.

5.6.3 Power Supply and Battery Pack (Model 1758) Checks

Table 5-4 shows the various checks that can be made to the power supplies within the Model 485 and 1758. In addition to the normal voltage checks, it is a good idea to check the various supplies with an oscilloscope to make sure no noise is present.

5.6.4 A/D Converter and Display

Make sure the A/D converter and display are operating properly before attempting to troubleshoot the signal conditioning circuit. Check these circuits using the information in Table 5-5 and 5-6.

Table 5-4. Power Supply Checks and Battery Pack (Model 1758) Checks

Step	Item/Component	Required Condition	Remarks
1	S102 Line Switch	Set to 115 or 230V as required.	S102 externally accessible from rear panel.
2	F101 Line Fuse	Continuity.	
3	Line Cord	Plugged into line receptacle; power on.	
4	U121** Input (TP1)	+12V \pm 10%	+5V regulator input.
5	U121** Output (TP3)	+5V \pm 5%	+5V regulator output.
6	U122 Input (TP2)	-20V to -14V	Negative supply input.
7	U122 Output (TP4)	-10V \pm 10%	Negative supply output.
8	VR103	-6.25V to -6.45V	Reference zener diode.
9	U107 pin 6	-7V \pm 5%	Low noise negative supply.
10*	Q101 base	0.6V while charging (power switch off).	Current sink.
11*	Battery Pack	Line cord disconnected, battery pack charged, power switch on.	
12*	U101 pin 8	> 8.8V	Voltage inverter.
13*	U102 pin 7	+5V with batteries charged.	Voltage comparator

*These items are located on the Model 1758 (if installed).

**If U121 is replaced, be sure that the device is properly seated on the mother board so that it will not touch the IEEE board (if installed).

Table 5-5. A/D Converter Checks

Step	Item/Component	Required Condition	Remarks
1		Turn on power; select 2mA range. Engage zero check.	
2	U120, pin 38	3.2768MHz Clock	Crystal (Y101)
3	U116, pin 10	655.36kHz Clock	Address Strobe
4	U116, pin 6	81.92kHz Clock	Synchronous Clock for A/D
5	U116, pin 5	40.96kHz Clock	Synchronous Clock for A/D
6	U116, pin 7	163.84kHz Clock	Stnchronous Clock for A/D
7	U116, pin 12	1.28kHz Clock	Integrator timebase and real time interrupt.
8	U115, pin 6	+5V to \approx 0V pulse train, 3 μ sec duration every 22 μ sec.	Charge balance synchronization signal.
9	U109, pin 6	Integrator Ramp	
10	U110B, pin 6	\approx 1.5V	Comparator Reference
11	U110B, pin 7	Variable pulse train 0V to +5V.	Comparator Output
12	U117A, pin 6	Variable pulse train, 0V to +5V.	Reference current generator.
13	U108B, pin 15	Variable pulse train, 0V to +5V.	
14	U108B, pin 10	\approx 5msec positive going pulses.	Control line for charge balance/single slope.
15	U117B, pin 9	100msec positive going pulse.	Control line for integrator.

Table 5-6. Display Board Checks

Step	Item/Component	Required Conditions	Remarks
1		Turn on power; select the 2mA range. Engage zero check	
2	P1006, pin 5	+3.33V	Vlcd1
3	P1006, pin 6	+1.66V	Vlcd2
4	P1006, pin 7	+5V \pm 5%	Power to display.
5	P1006, pin 2	81.92kHz	Display Clock
6	P1006, pin 1	0V to +5V Pulses	Data From μ p
7	P1006, pin 12	0V to +5V Pulses	Data From μ p
8	P1006, pin 13	0V to +5V Pulses	Data From μ p
9	P1006, pin 14	+5V to 0V Pulses	Data From μ p
10	LCD	Check that LCD is positioned properly.	
11	Connector (P1006)	Check that connector is not reversed. If reversed, display test will run, then display will blank.	
12	Strip Connectors*	Check that they are positioned properly.	

*See Figure 6-2.

5.6.5 Signal Conditioning

The circuit can be checked by using the diagnostic program (troubleshooting modes). See paragraph 5.4.2.

5.7 INPUT AMPLIFIER (U105) BALANCING

Part changes in the input section of the Model 485 may make it necessary to balance the offset of the input amplifier. If the instrument cannot be zeroed, as explained in paragraph 2.7.2, perform the following procedure:

WARNING

Disconnect line cord and remove all test leads from the terminals of the Model 485.

1. Remove the top cover as explained in paragraph 5.2.
2. Remove the shield. Four screws secure it to the mother board.
3. Referring to Figure 5-2, locate jumpers W101 and W102 on the mother board. If the jumpers have been cut or removed, replace them with new ones.
4. Connect the line cord and turn the power on.
5. Select the 2nA range and zero check.
6. Center the front panel ZERO pot and note the offset present on the display.
7. Follow Table 5-7 and cut the appropriate jumper.
8. Disconnect the line cord and install the shield and top cover.

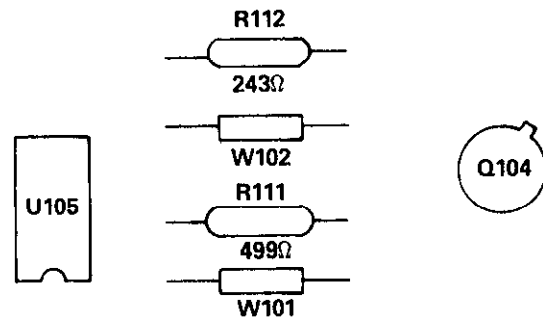

Figure 5-2. Jumper Locations

Table 5-7. Offset Jumper Set Up

Offset	Cut Jumper
- 800 to 800 counts	None
1600 to 2400 counts	W101
- 800 to -1600 counts	W102
800 to 1600 counts	W101 and W102

5.8 LINE FUSE REPLACEMENT

The line fuse is located internally in the Model 485. For exact fuse location, refer to Figure 6-1. To replace the fuse proceed as follows:

WARNING

Disconnect the line cord and all other sources before removing the top cover.

1. Remove the top cover as explained in paragraph 5.2.
2. If the Model 4853 IEEE-488 interface is installed it must be removed to gain access to the fuse. The IEEE board is secured to the mother board by a support post at the rear, and a connector on the left side. To remove, lift board up until it disengages from the connector and support post.
3. Replace the blown fuse with the following type: 1/8A, 250V, 3AG, Slo-Blo (Keithley P/N FU-20).

CAUTION

Do not use a fuse with a rating higher than specified or instrument damage may occur. If the instrument persistently blows fuses, a problem may exist within the instrument. If so, the problem must be rectified before continuing operation.

4. If the IEEE interface was installed, reinstall as follows:
 - A. Position the Model 4853 loosely on the rear standoff.

WARNING

Do not push down on the seven terminal, female connector (J1008). The male connector pins will pass through J1008 and may cause personal injury.

- B. Guide the pins of P1008 into J1008 and firmly push down on that end of the board to mate the connectors.
 - C. Push down on the other side of the IEEE board until it snaps onto the rear standoff. Make sure the board is seated properly on the front stand off.
5. Reinstall the top cover as explained in paragraph 5.2.

5.9 SPECIAL HANDLING OF STATIC SENSITIVE DEVICES

CMOS devices are designed to operate at very high impedance levels for low power consumption. As a result, any normal static charge that builds up on your person or clothing

may be sufficient to destroy these devices if they are not handled properly. Table 5-8 lists the static sensitive devices in the Model 485. When handling these devices, use the following precautions to avoid damaging them.

1. The ICs listed in Table 5-8 should be transported and handled only in containers specially designed to prevent static build-up. Typically, these parts will be received in static-protective containers until ready for installation.
2. Remove the devices from their protective containers only at a properly grounded work station. Also ground yourself with a suitable wriststrap.
3. Handle the devices only by the body; do not touch the pins.
4. PC boards must be grounded to bench while inserting devices.
5. Use only antistatic type solder suckers.
6. Use only grounded soldering irons.

Table 5-8. Static Sensitive Device

Schematic Designation	Keithley Part No.
U101, U102, U103, U108	IC-283
U106	IC-354
U111	LSI-61
U112	LSI-53
U113	LSI-52
U114	IC-143
U115	IC-341
U116	IC-348
U117	IC-337
U118	IC-351
U119	IC-338
U120	LSI-60
U101*	IC-340

*Part of Model 1758

SECTION 6 REPLACEABLE PARTS

6.1 INTRODUCTION

This section contains replacement parts information, component location drawings and schematic diagrams for the Model 485 and Model 1758.

6.2 REPLACEABLE PARTS

Parts are listed alpha-numerically in order of their circuit designation. Table 6-1 contains a parts list for the mother board. Table 6-2 contains a parts list for the display board. Table 6-3 contains a parts list for the Model 1758 Battery Pack. Miscellaneous replaceable parts list are not listed in a table but can be identified in Figures 6-1 and 6-2. Table 6-4 contains a complement of spare parts that can be ordered to maintain up to 10 Model 485's for approximately one year.

6.3 ORDERING INFORMATION

To place an order, or to obtain information concerning replacement parts, contact your Keithley representative or the factory. See the inside front cover for addresses. When ordering include the following information:

1. Instrument Model Number
2. Instrument Serial Number

3. Part Description
4. Circuit Designation (if applicable)
5. Keithley Part Number

If an additional instruction manual is required, order the manual package (Keithley Part Number 485-901-00). The manual package includes an instruction manual and all pertinent addenda.

6.4 FACTORY SERVICE

If the instrument is to be returned to the factory for service, please complete the service form which follows this section and return it with the instrument.

6.5 COMPONENT LOCATION DRAWINGS AND SCHEMATIC DIAGRAMS

- Figure 6-3. Display Board, Component Layout
- Figure 6-4. Model 1758 Battery Pack, Component Layout
- Figure 6-5. Mother Board, Component Layout
- Figure 6-6. Mother Board, Schematic Diagram
- Figure 6-7. Display Board, Schematic Diagram
- Figure 6-8. Model 1758 Battery Pack, Schematic Diagram

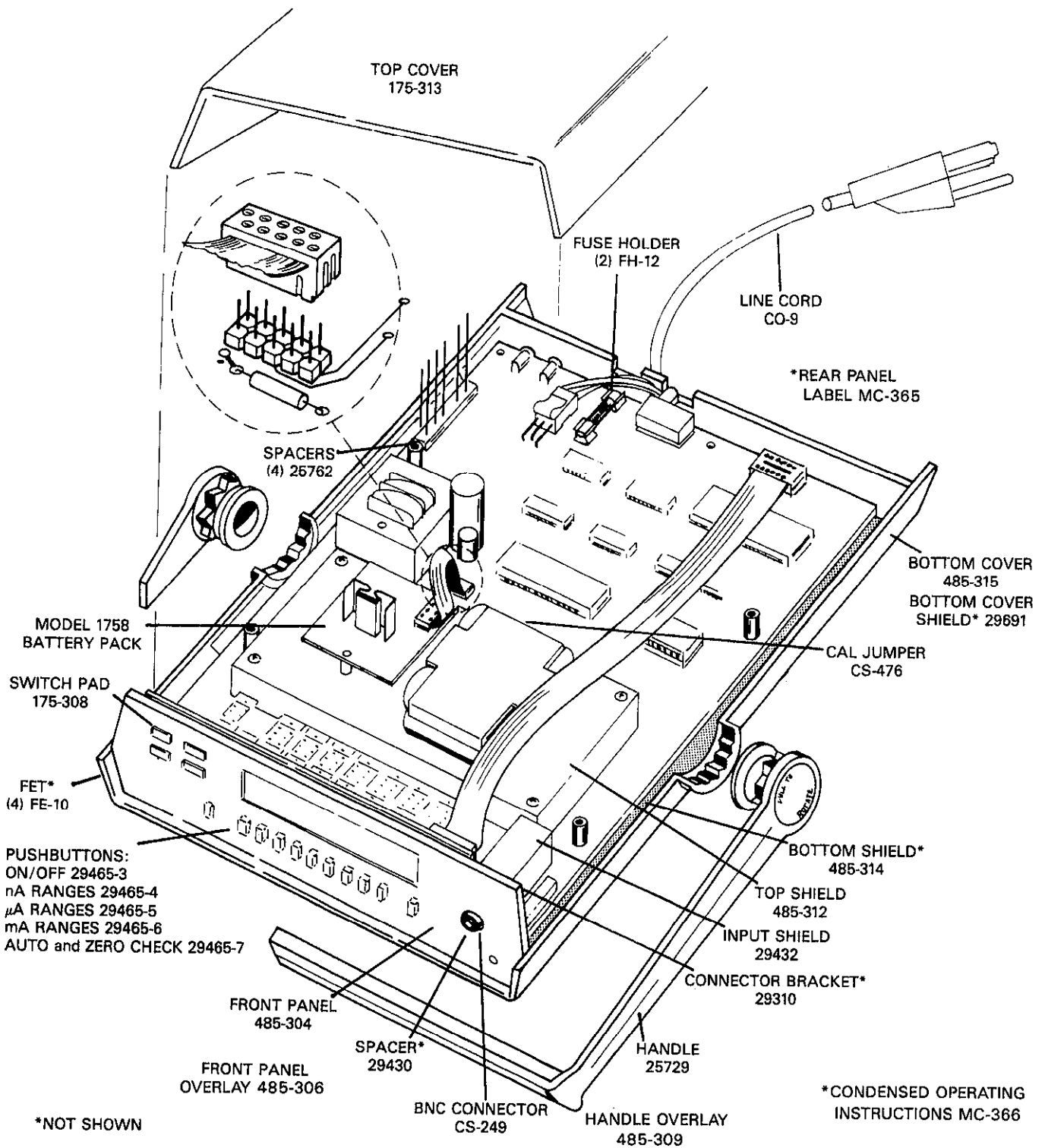

Figure 6-1. Model 485 Exploded View

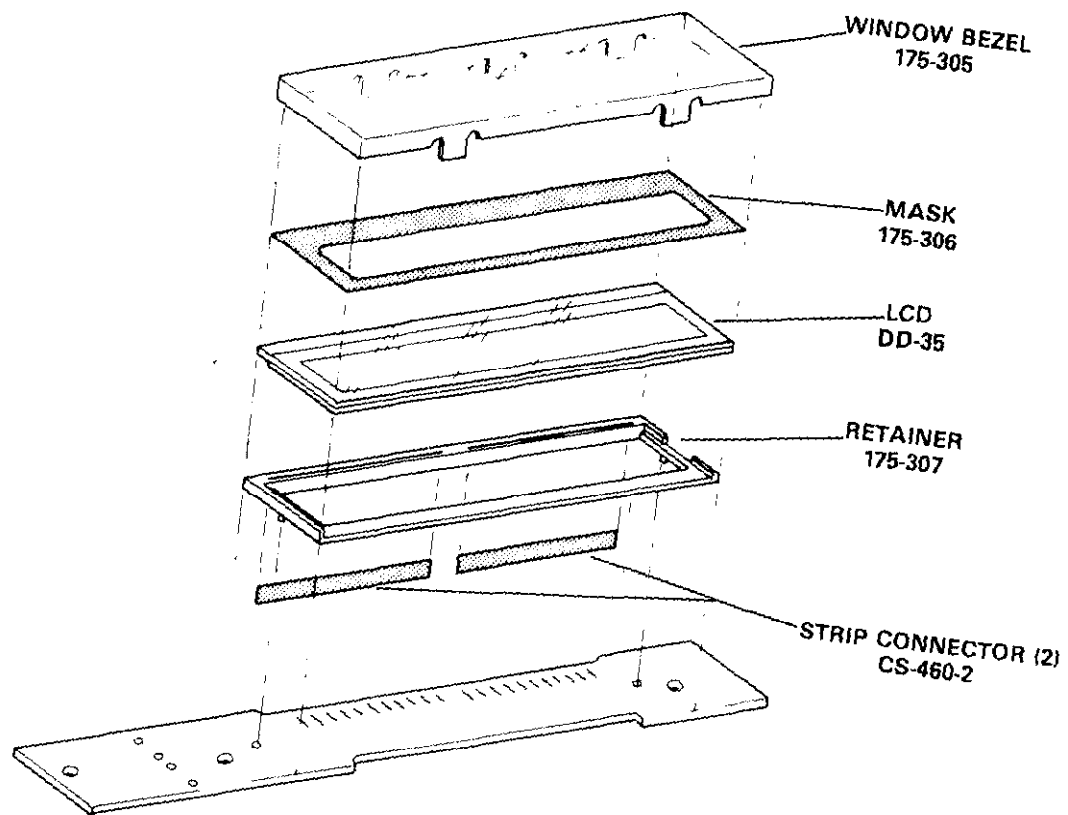

Figure 6-2. Display Assembly

Table 6-1. Model Board, Parts List

Circuit Desig.	Description	Location		Keithley Part No.
		Sch*	Pcb	
C101	Not Used			
C102	Capacitor, .01 μ F, 50V, Metal Polycarbonate	C3-1	C4	C-201-.01
C103	Not Used			
C104	Capacitor, 220pF, 500V, Polystyrene	C4-1	C5	C-138-220p
C105	Capacitor, 10pF, 1000V, Ceramic Disk	B5-1	C5	C-64-10p
C106	Capacitor, 100pF, 1000V, Ceramic Disk	D5-1	C3	C-64-100p
C107	Capacitor, .1 μ F, 50V, Ceramic Film	D5-1	D3	C-237-.1
C108	Capacitor, .1 μ F, 50V, Ceramic Film	D5-1	D3	C-237-.1
C109	Capacitor, 1 μ F, 50V, Metal Polycarbonate	E3-1	C3	C-335-1
C110	Capacitor, 10 μ F, 25V, Aluminum Electrolytic	G4-1	C2	C-314-10
C111	Capacitor, .01 μ F, 100V, Metal Polypropylene	B1-2	D3	C-306-.01
C112	Capacitor, .1 μ F, 50V, Ceramic Film	B5-2	D5	C-237-.1
C113	Capacitor, .1 μ F, 50V, Ceramic Film	D6-2	E5	C-237-.1
C114	Capacitor, .1 μ F, 50V, Ceramic Film	E3-2	E4	C-237-.1
C115	Capacitor, 22pF, 1000V, Ceramic Disk	E6-2	F5	C-64-22p
C116	Capacitor, 22pF, 1000V, Ceramic Disk	E6-2	F5	C-64-22p
C117	Capacitor, .1 μ F, 50V, Ceramic Film	F3-2	F4	C-237-.1
C118	Capacitor, 1500 μ F, 25V, Aluminum Electrolytic	F1-2	E3	C-314-1500
C119	Capacitor, 4.7 μ F, 25V, Aluminum Electrolytic	G1-2	E3	C-314-4.7
C120	Capacitor, 4.7 μ F, 25V, Aluminum Electrolytic	H1-2	E3	C-314-4.7
C121	Capacitor, 4.7 μ F, 25V, Aluminum Electrolytic	H1-2	E3	C-314-4.7
C122	Capacitor, 250 μ F, 25V, Aluminum Electrolytic	G1-2	D3	C-314-220
C123	Capacitor, .1 μ F, 50V, Ceramic Film	B1-1	D4	C-237-.1
C124	Capacitor, .1 μ F, 50V, Ceramic Film	E4-1	F2	C-237-.1
CR101	Bridge Rectifier, VM18	F1-2	D3	RF-52
F101	Fuse, 250V, 1/8A, 3AG, Slo-Blo	E1-2	F3	FU-20
J1001	Connector, BNC, Female	A1-1	A5	CS-249
J1002	Connector, Modified	E4-1	F2	29316
J1003	Connector, Modified	E4-1	F2	29316
J1006	Socket	Sev	F5	SO-70
J1009	Connector, Male, 10-Pin	Sev	D3	CS-389-4
K101	Relay, 5V	B2-1	C5	RL-70
K102	Relay, 5V	C4-1	C5	RL-70
K103	Relay, 5V	C5-1	C5	RL-70
P1004	Connector, Modified	E1-2	E2	175-316
P1008	Connector, Modified	Sev	E2	175-321
Q101	JFET, N-Channel, 2N4392	D2-1	C3	TG-169
Q102	JFET, N-Channel	D2-1	C3	TG-130
Q103	JFET, N-Channel, J210	D3-1	C3	TG-167
Q104	Transistor, MP-831-1010	C4-1	C4	TG-156
Q105	JFET, N-Channel, J210	F1-1	B2	TG-167
Q106	JFET, N-Channel, J210	F1-1	C2	TG-167
Q107	JFET, N-Channel, J210	F2-1	C2	TG-167
Q108	JFET, N-Channel, J210	F3-1	C2	TG-167
Q109	FET, N-Channel	B2-2	D2	TG-128
Q110	Transistor, NPN, Silicon, 5818	C2-1	C4	TG-138
Q111	Transistor, NPN, Silicon, 5818	C2-1	C4	TG-138
R101	Resistor, 1k Ω , 0.1%, 1W, Wirewound	C2-1	C4	R-249-1k
R102	Resistor, 100k Ω , 5%, 1/4W, Composition	D2-1	C3	R-76-100k
R103	Resistor, 11k Ω , 0.1%, 1/10W, Metal Film	C2-1	C4	R-263-11k
R104	Resistor, 100k Ω , 5%, 1/4W, Composition	D3-1	C3	R-76-100k

Table 6-1. Mother Board, Parts List (Cont.)

Circuit Desig.	Description	Location		Keithley Part No.
		Sch*	Pcb	
R105	Resistor, 100k Ω , 0.1%, 1/10W, Metal Film	C3-1	C4	R-263-100k
R106	Resistor, 1.1M Ω , 0.1%, 1/8W	C3-1	C4	R-176-1.1M
R107	Resistor, 11M Ω , 0.7%, 1W, Cermet Film	D4-1	B4	R-302-11M
R108	Resistor, 99M Ω , 0.5%, 1/4W, Metal Oxide	C4-1	C5	R-269-99M
R109	Resistor, 10M Ω , 10%, 1/4W, Composition	B5-1	C5	R-76-10M
R110	Resistor, 220k Ω , 5%, 1/4W, Composition	B5-1	C5	R-76-220k
R111	Resistor, 499 Ω , 1%, 1/8W, Composition	C5-1	C4	R-88-499
R112	Resistor, 243 Ω , 1%, 1/8W, Composition	D5-1	D4	R-88-243
R113	500 Ω , 10%, 3/4W, Pot	C5-1	B5	RP-89-500
R114	Resistor Set, 260k Ω , 0.1%	C5-1	C3	R-306
R115	Resistor Set, 260k Ω , 0.1%	D5-1	D3	R-306
R116	Resistor, 10k Ω , 5%, 1/4W, Composition	E3-1	C3	R-76-10k
R117	Resistor, 910 Ω , 10%, 1W, Composition	E4-1	C3	R-2-910
R118	Thick Film Resistor Network	Sev	C2	TF-169
R119	Resistor, 100k Ω , 5%, 1/4W, Composition	E1-1	B3	R-76-100k
R120	Thick Film Resistor Network	Sev	C3	TF-172
R121	Thick Film Resistor Network	Sev	E3	TF-173
R122	Thick Film Resistor Network	Sev	C2	TF-171
R123	Resistor, 100k Ω , 5%, 1/4W, Composition	E1-1	C3	R-76-100k
R124	Resistor, 10M Ω , 10%, 1/4W, Composition	F6-2	F5	R-76-10M
R125	Resistor, 27 Ω , 10%, 2W, Composition	F1-2	E3	R-3-27
R126	Resistor, 8.06k Ω , 1%, 1/8W, Composition	G1-2	E3	R-88-8.06k
R127	Resistor, 1.24k Ω , 1%, 1/8W, Composition	G2-2	E3	R-88-1.24k
R128	Resistor, 47k Ω , 5%, 1/4W, Composition	H5-2	D3	R-76-47k
R129	Resistor, 100 Ω , 5%, 1W, Composition	E4-1	E2	R-76-100
R130	Resistor, 5.1k Ω , 5%, 1/4W, Composition	C4-1	B5	R-76-5.1k
S101	Pushbutton Switch Station	Sev	B3	SW-455
S102	Line Switch	E1-2	F3	SW-318
T101	Transformer, Power (105-125V, 210-250V)	F1-2	D2	TR-201
U101	Triple 2-Channel Analog Multiplexer, CD4053BC	Sev	C3	IC-283
U102	Triple 2-Channel Analog Multiplexer, CD4053BC	Sev	C2	IC-283
U103	Triple 2-Channel Analog Multiplexer, CD4053BC	Sev	C2	IC-283
U104	Programmable Op Amp, TLC271	F2-1	C2	IC-347
U105	Linear Op Amp LM308AN	D5-1	C3	IC-203
U106	Hex Inverter, 74HC04	Sev	D4	IC-354
U107	Programmable Op Amp, TLC271	F4-1	C2	IC-347
U108	Triple 2-Channel Analog Multiplexer, CD4053BC	Sev	D2	IC-283
U109	Op Amp, TL061CP	B2-2	C3	IC-227
U110	Dual Voltage Comparator, LM393	C2-2	C3	IC-343
U111	Peripheral Interface Adapter, 65C21	C4-2	D3	LSI-61
U112	1024 \times 4 Bit Static CMOS RAM	A6-2	D5	LSI-53
U113	8k \times 8 UV Erasable PROM	C6-2	D5	485-800-**
U114	Triple 3-Input OR Gate, CD4075BE	Sev	E3	IC-143
U115	Triple 3-Input NAND Gate, MM74HC10	Sev	E4	IC-341
U116	12 Stage Binary Counter, 4040B	D3-2	E4	IC-348

Table 6-1. Mother Board, Parts List (Cont.)

Circuit Desig.	Description	Location		Keithley Part No.
		Sch*	Pcb	
U117	Dual D Flip-Flop, 74HC74	D3-2	E3	IC-337
U118	Quad 2-Input NAND Gate, 74HC00	Sev	D4	IC-351
U119	Tri-State Octal D Latch, 74HC373	D6-2	E5	IC-338
U120	CMOS 8-Bit Microprocessor, 146805E2	Sev	F5	LSI-60
U121	Regulator, +5V, 1A, 7805	H1-2	E2	IC-93
U122	3-Terminal Adjustable Regulator, LM337L	G2-2	E3	IC-345
U123	16 × 16 Bit Serial Nonvolatile Static RAM, X2443P	H5-2	D3	IC-353
VR101	Diode, 2.3V-2.9V, 1N702A	E4-1	C3	DZ-33
VR102	Diode, 2.3V-2.9V, 1N702A	E4-1	C3	DZ-33
VR103	Diode, Zener, 6.35V, 400mW, 1N4577	F4-1	C3	DZ-58
VR104	Diode, Zener, 5.1V, 400mV, 1N751	G4-1	C2	DZ-59
VR105	Diode, Zener, 12V, 1N963B	H1-2	D3	DZ-54
VR106	Diode, Zener, 12V, 5W, 1N5349	H2-2	E3	DZ-72-1
W101	Jumper	C5-1	C4	J-3
W102	Jumper	D5-1	C4	J-3
W103	Calibration Jumper	H6-2	D4	CS-476
Y101	Crystal, 3.2768MHz	E6-2	F5	CR-21

*Zone and page number e.g. B2-1 corresponds to zone B2 on page 1 of schematic.

**Order same software as presently installed. For example, if A1 is the displayed software, order 485-800-A1.

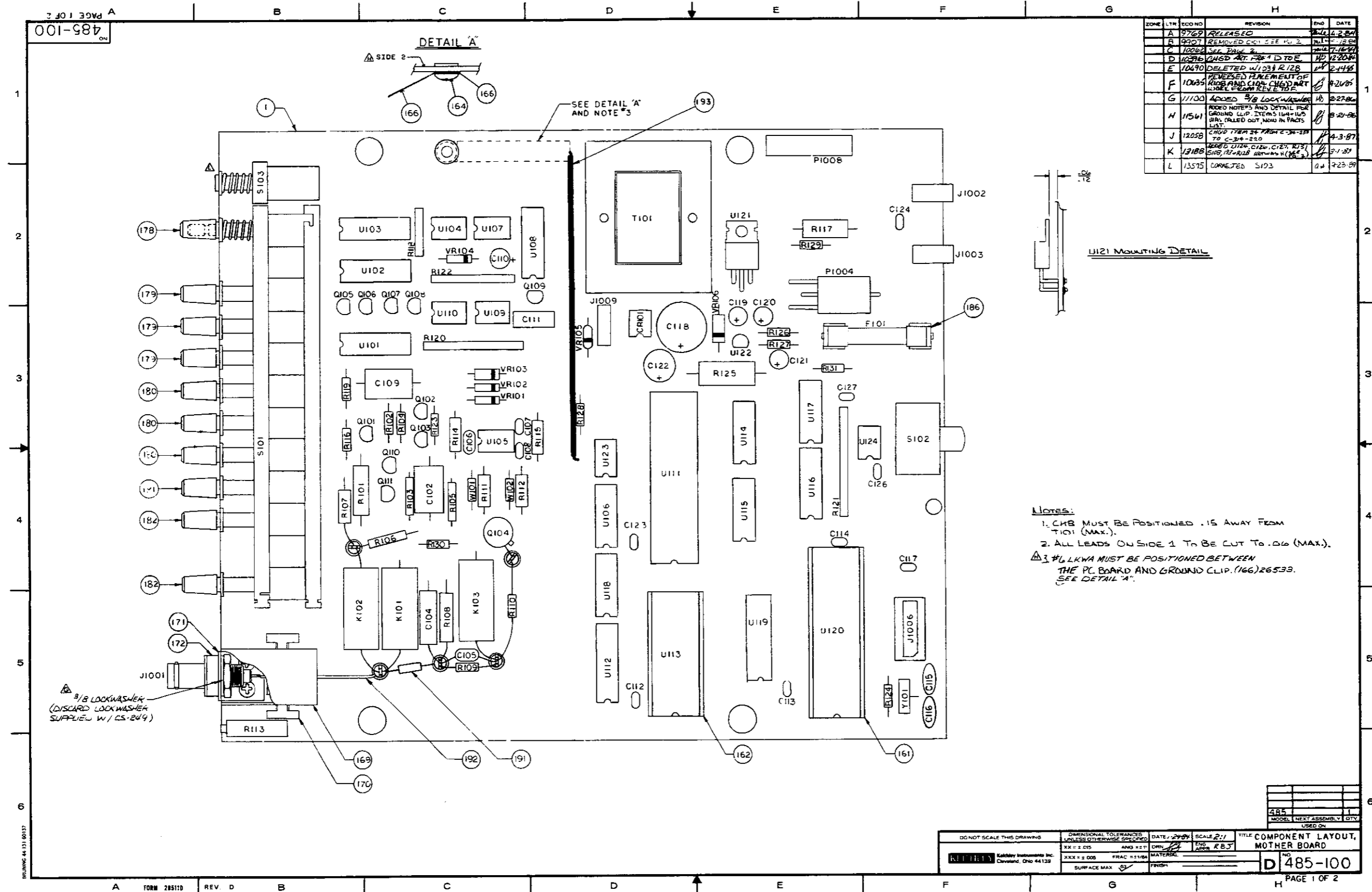
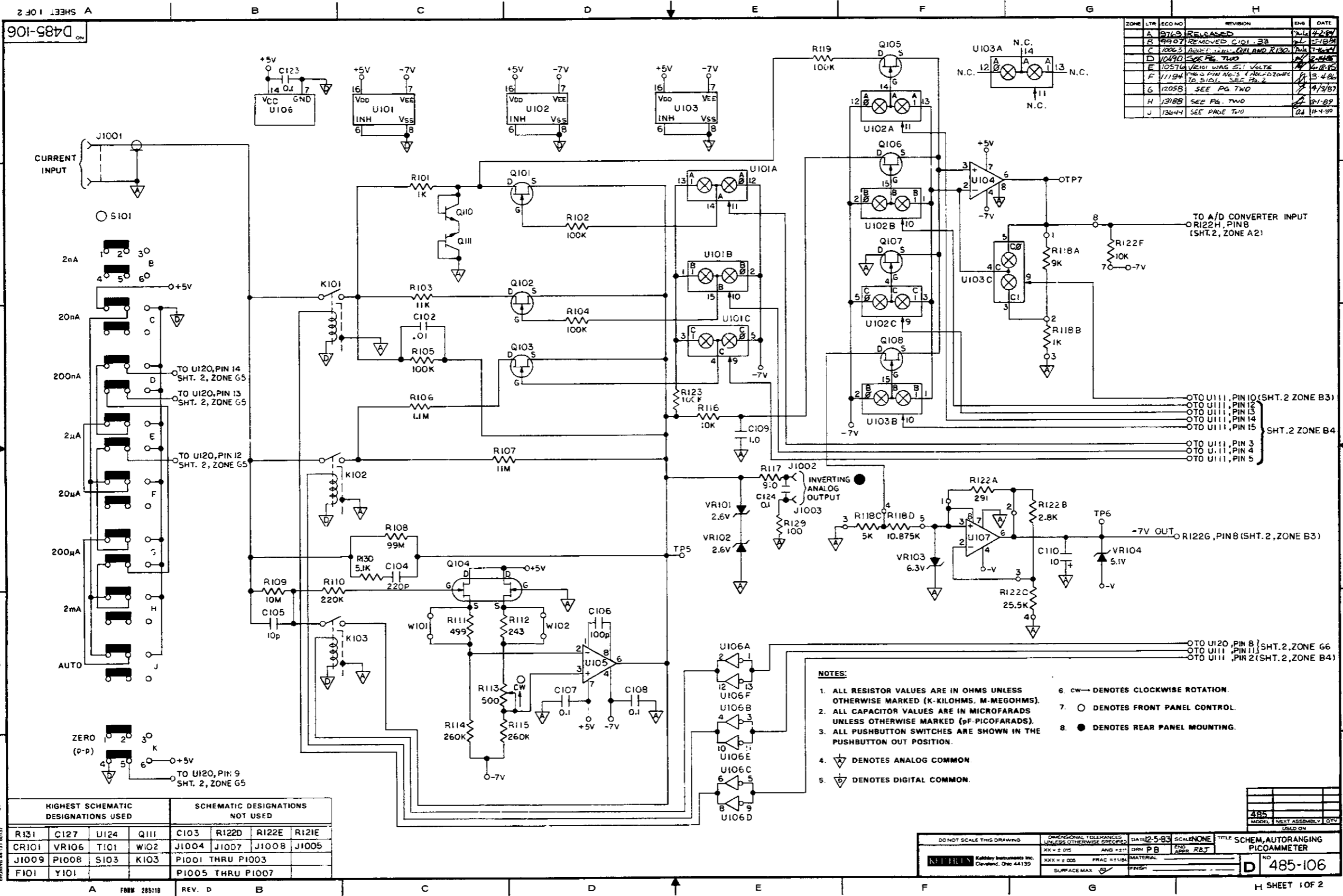

Figure 6-3. Mother Board, Component Location Drawing, Dwg. No. 485-100



ZONE	LTR	ECO NO	REVISION	ENG	DATE
A	9769		RELEASED		7/2/87
B	9907		REMOVED C101, B3		5/18/87
C	10063		ADD 1.5K OHM Q101 AND R130		7/2/87
D	10490		SEE PG TWO		12/1/87
E	10576		VR101 WAS 5.1 VOLTS		12/1/87
F	11194		PHAS 2 PIN NO. 5 & ADJ. 2 ZONES TO S101 - SEE PG 2		3/4/88
G	12058		SEE PG TWO		4/9/87
H	13188		SEE PG TWO		5/1/89
J	13644		SEE PAGE TWO		04/11/99

HIGHEST SCHEMATIC DESIGNATIONS USED				SCHEMATIC DESIGNATIONS NOT USED			
R131	C127	U124	Q111	C103	R122D	R122E	R121E
CR101	VR106	T101	W102	J1004	J1007	J1008	J1005
J1009	P1008	S103	K103	P1001	THRU	P1003	
F101	Y101			P1005	THRU	P1007	

- NOTES:**
1. ALL RESISTOR VALUES ARE IN OHMS UNLESS OTHERWISE MARKED (K-KILOHMS, M-MEGOHMS).
 2. ALL CAPACITOR VALUES ARE IN MICROFARADS UNLESS OTHERWISE MARKED (PF-PICOFARADS).
 3. ALL PUSHBUTTON SWITCHES ARE SHOWN IN THE PUSHBUTTON OUT POSITION.
 4. ▽ DENOTES ANALOG COMMON.
 5. ▽ DENOTES DIGITAL COMMON.
 6. cw— DENOTES CLOCKWISE ROTATION.
 7. ○ DENOTES FRONT PANEL CONTROL.
 8. ● DENOTES REAR PANEL MOUNTING.

DO NOT SCALE THIS DRAWING	DIMENSIONAL TOLERANCES UNLESS OTHERWISE SPECIFIED	DATE 2-5-83	SCALE NONE	TITLE SCHEM, AUTORANGING PICOAMMETER
REVISION	XX ± 0.05	ANG ± 0.10	DRAW BY PB	CHK APPR RBJ
	XXX ± 0.005	FRAC ± 0.10	MATERIAL	
	SURFACE MAX	FINISH		

NO. **485-106**

Figure 6-4. Mother Board, Schematic Diagram, Dwg. No. 485-106 (sheet 1 of 2)

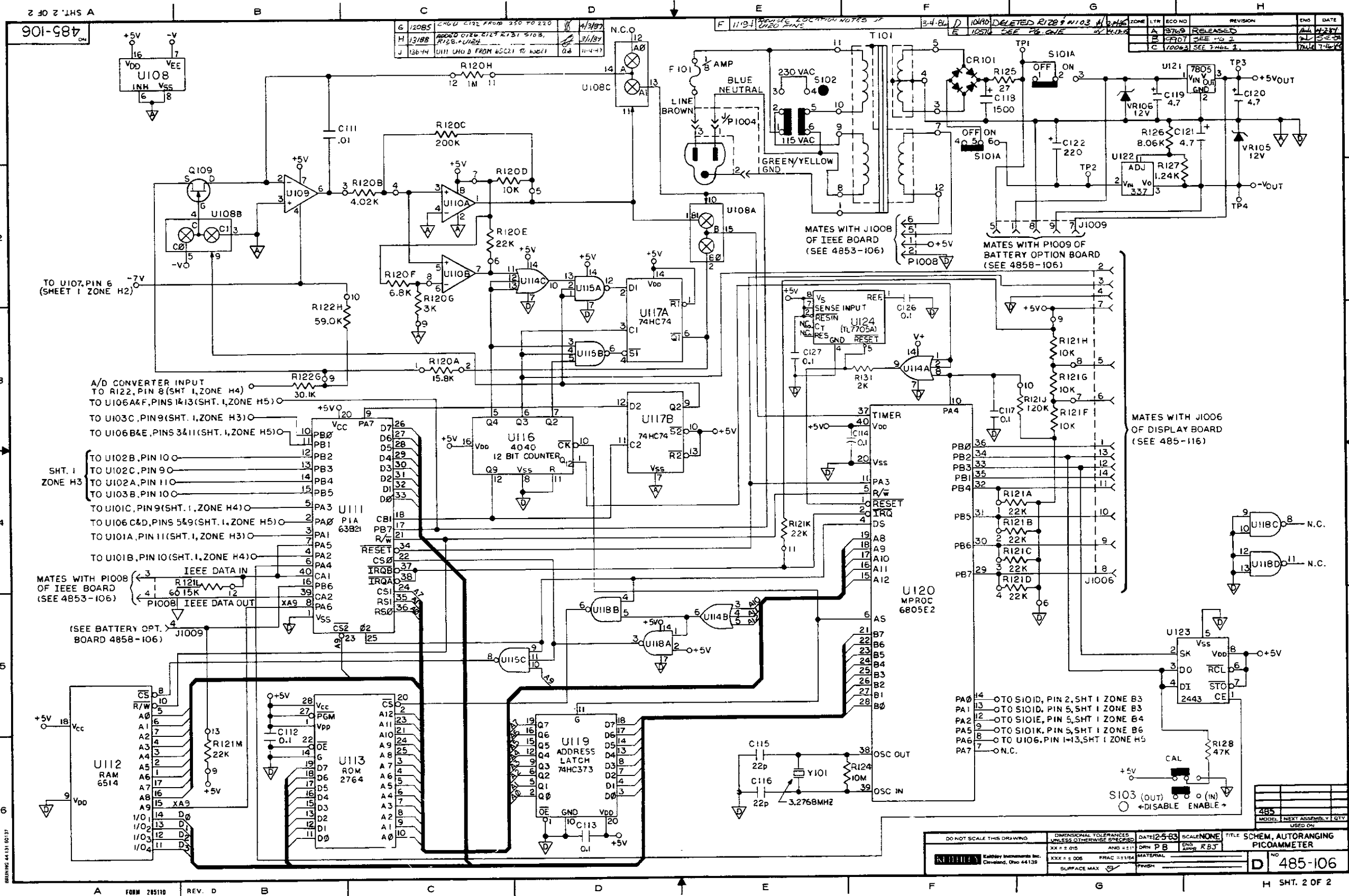

485-106
2 OF 2

REV	DATE	BY	CHKD	DESCRIPTION
G	12/05			CHG'D C112 FROM 220 TO 220
H	12/18			ADD'D C126, R127, R128, S103, R128, U124
J	12/94			U111 LHO B FROM 65C21 TO 63821

TO U107, PIN 6 (SHEET 1, ZONE H2)

A/D CONVERTER INPUT TO R122, PIN 8 (SHT 1, ZONE H4)

TO U106A&F, PINS 1&13 (SHT. 1, ZONE H5)

TO U102B, PIN 10

TO U102C, PIN 9

TO U102A, PIN 11

TO U103B, PIN 10

TO U101C, PIN 9 (SHT. 1, ZONE H4)

TO U106 C&D, PINS 5&9 (SHT. 1, ZONE H5)

TO U101A, PIN 11 (SHT. 1, ZONE H3)

TO U101B, PIN 10 (SHT. 1, ZONE H4)

IEEE DATA IN

IEEE DATA OUT

(SEE BATTERY OPT. BOARD 4858-106)

MATES WITH J1006 OF DISPLAY BOARD (SEE 485-116)

DO NOT SCALE THIS DRAWING	DIMENSIONAL TOLERANCES UNLESS OTHERWISE SPECIFIED	DATE: 2-5-83	SCALE: NONE	TITLE: SCHEM. AUTORANGING PICOAMMETER
XXX = 2.008	FRAC = 1/1000	FINISH: SURFACE MAX		

Mother Board, Schematic Diagram, Dwg. No. 485-106 (sheet 2 of 2)

Table 6-2. Display Board, Parts List

Circuit Desig.	Description	Location		Keithley Part No.
		Pcb	Sch	
DS-201	Liquid Crystal Display	E2	D3	DD-35
P1006	Cable Assembly (14 Conductor)	C4	C4	CA-9-3
U201	LCD Controller/Driver	D4	C4	LSI-59

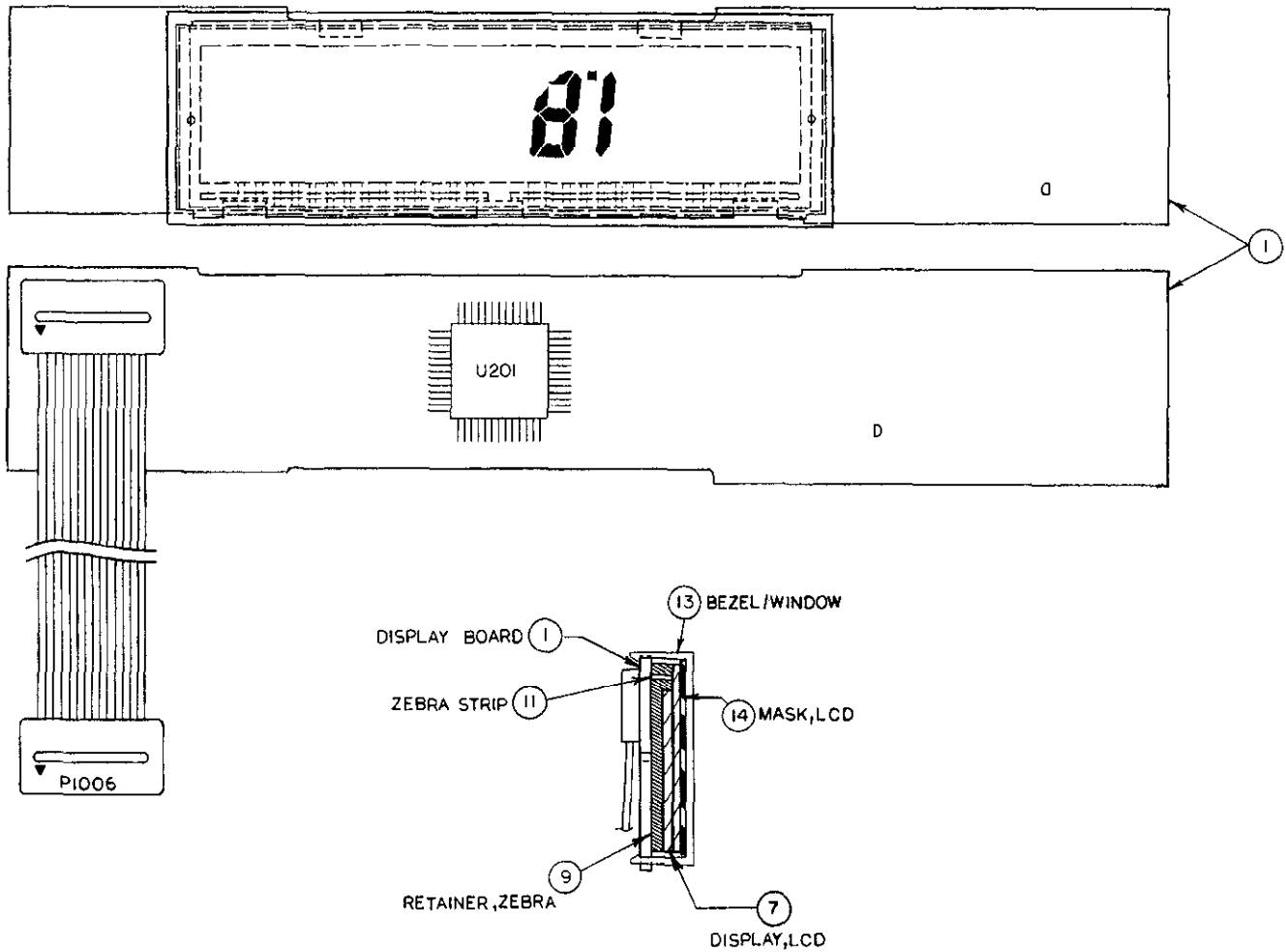

ZONE	LTR	ECO NO	REVISION	ENG	DATE
A		0769	RELEASED	ML	4-2-94
B		0995	PC ART WORK WAS REV C	ML	2-5-94

Figure 6-5. Display Board, Component Location Drawing, Dwg. No. 485-110

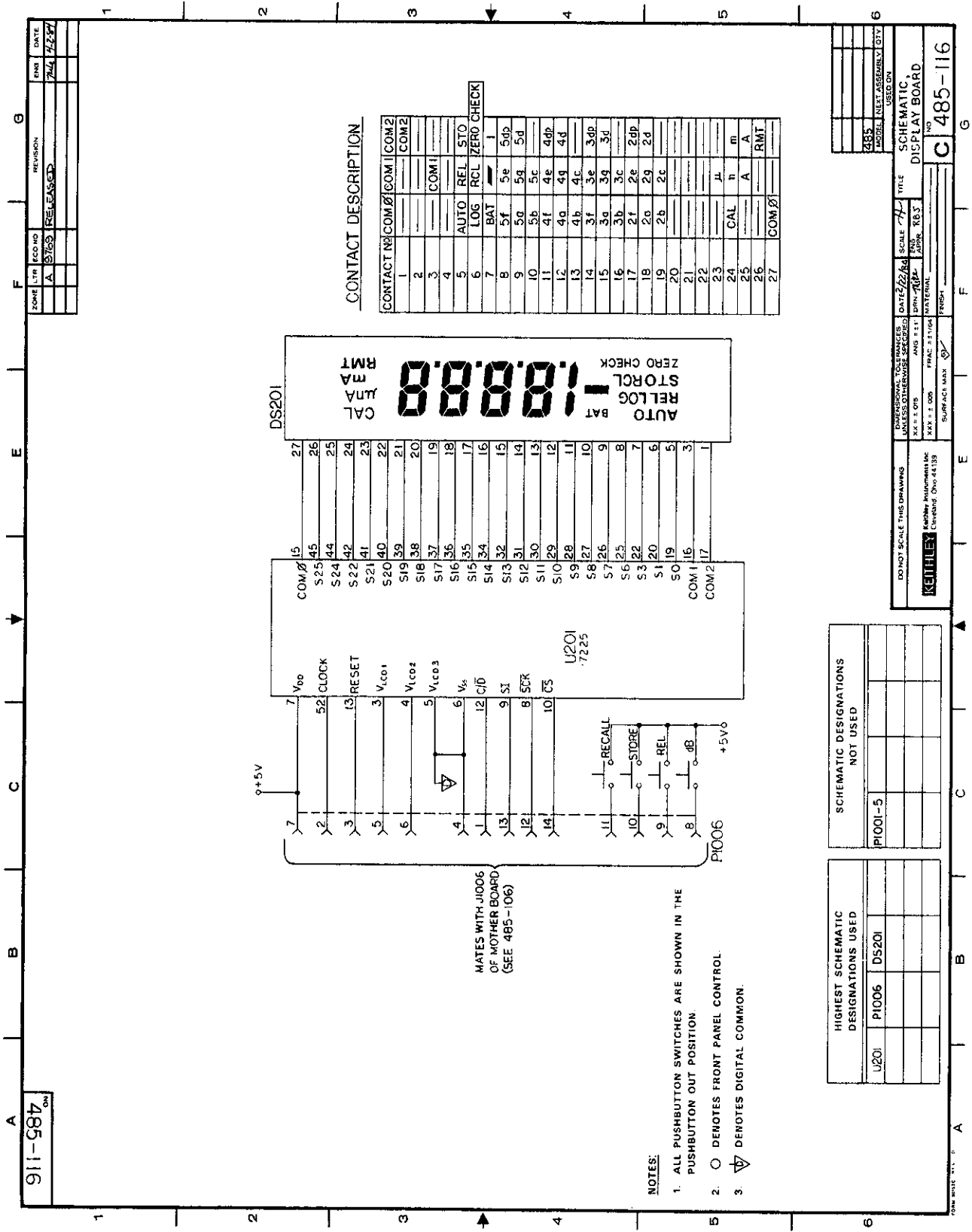

Figure 6-6. Display Board, Schematic Diagram Drawing, Dwg. No. 485-116

Table 6-3. Model 1758 Battery Pack, Parts List

Circuit Desig.	Description	Location		Keithley Part No.
		Pcb	Sch	
BT101	Battery Assembly, 9.6V sealed rechargeable Ni Cad	—	B3	BA-38
C101	Capacitor, 250 μ F, 25VDC, Aluminum Electrolytic	D2	E4	C-314-220
C102	Capacitor, 10 μ F, 25VDC, Aluminum Electrolytic	D3	C4	C-314-10
CR101	Rectifier, Schottky Barrier, 1N5820	D2	D4	RF-53
J1010	Pin	D3	B3	CS-463
J1011	Pin	D2	B3	CS-463
P1009	Cable Assembly, 10 Conductor	D2	B1	CA-27-1
R101	Resistor, 4.7 Ω , 10%, 1/2W, Composition	E2	C3	R-1-4.7
R102	Resistor, 4.7 Ω , 5%, 1/4W, Composition	E1	C2	R-76-4.7
R103	Resistor, 30.1k Ω , 1%, 1/8W, Metal Film	E3	E3	R-88-30.1k
R104	Resistor, 39.2k Ω , 1%, 1/8W, Metal Film	E3	E4	R-88-39.2k
R105	Resistor, 1.2M Ω , 5%, 1/4W, Composition	D3	E3	R-76-1.2M
RT101	PTC Thermister	D2	B2	RT-10
Q101	Transistor, NPN, High Voltage (TIP-49)	D3	C2	TG-137
U101	Voltage Converter, SI7661	D3	D4	IC-340
U102	Voltage Comparator, LM393	D3	E3	IC-343
—	Heat Sink (used on U101)	D3	—	HS-28
—	Standoff (Battery Board to Shield)	D3	—	ST-137-8
—	Battery Bracket	—	—	1758-305

LTR	ECO NO.	REVISION	ENG.	DATE
A		PRELIMINARY		
B		PRELIMINARY		
C	9450	RELEASED		9/30/83
D	9572	REV. WAS REV. ADDED ITEM 25 ITEM 17 WAS R-76	MHL	1-24-84
E	9806	ITEMS 11 & 12 WERE CS-357 DELETED DETAIL "A"	MHL	4-7-84
F	10402	R101 WAS R-1-4.7	M/S	12-27-84
G	10967	ARTWORK WAS REV. D	B	2-20-86
H	1205B	CHG'D ITEM 3 FROM C-314-250 TO C-314-220	A	4-3-87

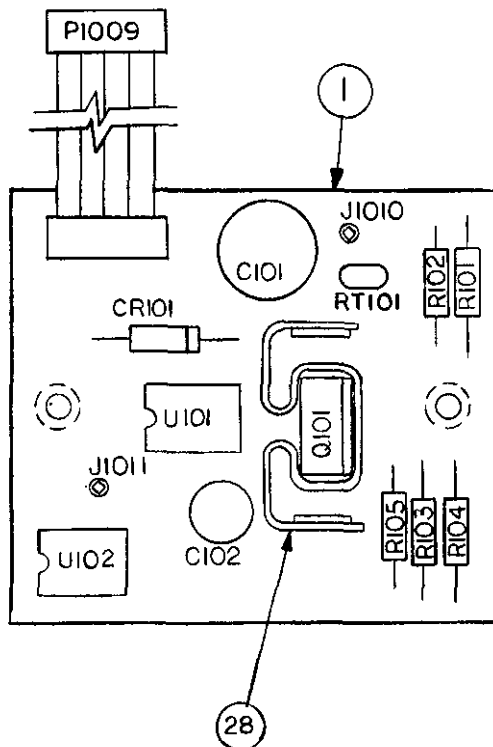

Figure 6-7. Battery Pack, Component Location Drawing, Dwg. No. 1758-100

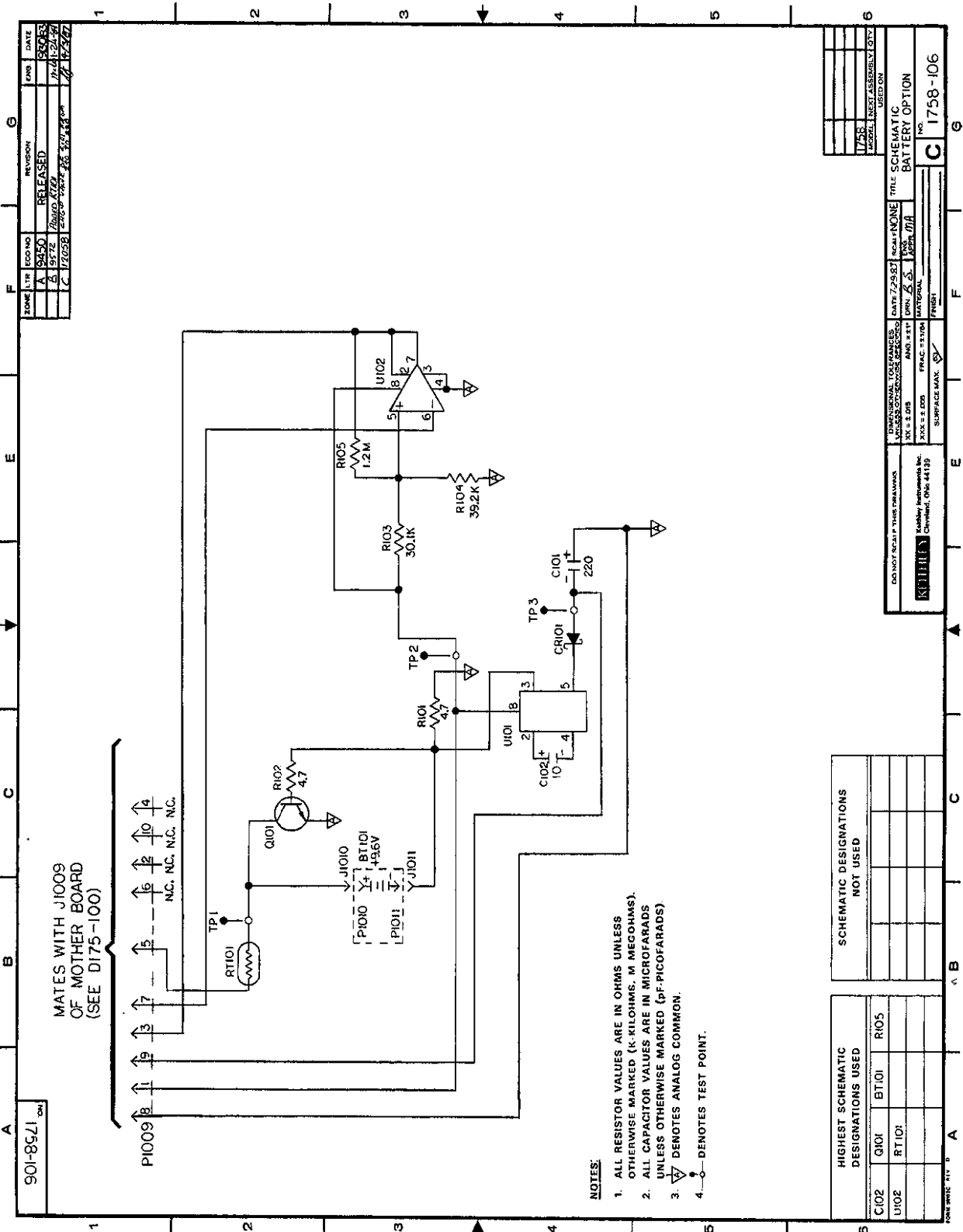

Figure 6-8. Battery Pack, Schematic Diagram Drawing, Dwg. No. 1758-106

Table 6-4. Model 485 Spare Parts List

Qty.	Keithley Part No.	Circuit Desig.
2	FU-20	F101
1	RL-70	K101, K102, K103
4	TG-167	Q103, Q105, Q106 Q107, Q108
1	TG-128	Q109
1	IC-347	U104, U107
2	IC-283	U101, U102, U103, U108
1	IC-353	U123
1	IC-354	U106
1	IC-351	U118
1	IC-93	U121
1	IC-345	U122
1	DZ-58	VR101
1	DZ-72-1	VR102
1	IC-203	U105
5	TG-169	Q101
1	TG-130	Q102
1	TG-156	Q104



Service Form

Model No. _____ Serial No. _____ Date _____

Name and Telephone No. _____

Company _____

List all control settings, describe problem and check boxes that apply to problem. _____

- | | | |
|--|--|--|
| <input type="checkbox"/> Intermittent | <input type="checkbox"/> Analog output follows display | <input type="checkbox"/> Particular range or function bad; specify |
| <input type="checkbox"/> IEEE failure | <input type="checkbox"/> Obvious problem on power-up | <input type="checkbox"/> Batteries and fuses are OK |
| <input type="checkbox"/> Front panel operational | <input type="checkbox"/> All ranges or functions are bad | <input type="checkbox"/> Checked all cables |

Display or output (check one)

- | | |
|-----------------------------------|--|
| <input type="checkbox"/> Drifts | <input type="checkbox"/> Unable to zero |
| <input type="checkbox"/> Unstable | <input type="checkbox"/> Will not read applied input |
| <input type="checkbox"/> Overload | |

- | | |
|---|--|
| <input type="checkbox"/> Calibration only | <input type="checkbox"/> Certificate of calibration required |
| <input type="checkbox"/> Data required | |

(attach any additional sheets as necessary)

Show a block diagram of your measurement system including all instruments connected (whether power is turned on or not). Also, describe signal source.

Where is the measurement being performed? (factory, controlled laboratory, out-of-doors, etc.)

What power line voltage is used? _____ Ambient temperature? _____ °F

Relative humidity? _____ Other? _____

Any additional information. (If special modifications have been made by the user, please describe.)

Be sure to include your name and phone number on this service form.