

DAVE & LYNN HENDERSON
ARTEKMEDIA
18265 200TH St EAST
WELCH, MN 55089
UNITED STATES of AMERICA

OPERATING AND SERVICE MANUAL

AUTOMATIC SYNTHESIZER 3330A/B

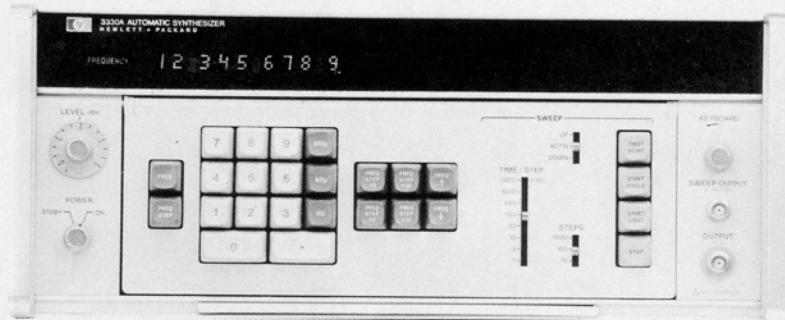

HEWLETT  PACKARD

DIGITALY REMASTERED
OUT OF PRINT- MANUAL SCANS

By

Artek Media

18265 200th St.
Welch, MN 55089

www.artekmedia.com

“High resolution scans of obsolete technical manuals”

If your looking for a quality scanned technical manual in PDF format please visit our WEB site at www.artekmedia.com or drop us an email at manuals@artekmedia.com and we will be happy to email you a current list of the manuals we have available.

If you don't see the manual you need on the list drop us a line anyway we may still be able to point you to other sources. If you have an existing manual you would like scanned please write for details. This can often be done very reasonably in consideration for adding your manual to our library.

Typically the scans in our manuals are done as follows;

- 1) Typed text pages are typically scanned in black and white at 300 dpi.
- 2) Photo pages are typically scanned in gray scale mode at 600 dpi
- 3) Schematic diagram pages are typically scanned in black and white at 600 dpi unless the original manual had colored high lighting (as is the case for some 70's vintage Tektronix manuals).
- 4) Most manuals are text searchable
- 5) All manuals are fully bookmarked

All data is guaranteed for life (yours or mine ... which ever is shorter). If for ANY REASON your file becomes corrupted, deleted or lost, Artek Media will replace the file for the price of shipping, or free via FTP download.

Thanks

Dave & Lynn Henderson
Artek Media



OPERATING AND SERVICE MANUAL

MODEL 3330A/B AUTOMATIC SYNTHESIZER

3330A
Serial No. 1301A00203 and Greater

3330B
Serial No. 1313A01161 and Greater

IMPORTANT NOTICE

Any changes made in instruments with serial numbers greater than those stated on this title page will be noted on a change sheet supplied with this manual. If the serial number of your instrument is lower than that stated above, the manual can contain revisions that do not apply to your instrument. Backdating information located in Section VIII adapts this manual to these instruments.

WARNING

To help minimize the possibility of electrical fire or shock hazards, do not expose this instrument to rain or excessive moisture.

Manual Part No. 03330-90002

Microfiche Part No. 03330-90052

Copyright Hewlett-Packard Company 1972
P.O. Box 301, Loveland, Colorado, 80537 U.S.A

Printed: December 1976

HEWLETT  PACKARD

CERTIFICATION

Hewlett-Packard Company certifies that this instrument met its published specifications at the time of shipment from the factory. Hewlett-Packard Company further certifies that its calibration measurements are traceable to the United States National Bureau of Standards, to the extent allowed by the Bureau's calibration facility, and to the calibration facilities of other International Standards Organization members.

WARRANTY AND ASSISTANCE

This Hewlett-Packard product is warranted against defects in materials and workmanship for a period of one year from the date of shipment, except that in the case of certain components, if any, listed in Section I of this operating manual, the warranty shall be for the specified period. Hewlett-Packard will, at its option, repair or replace products which prove to be defective during the warranty period provided they are returned to Hewlett-Packard, and provided the proper preventive maintenance procedures as listed in this manual are followed. Repairs necessitated by misuse of the product are not covered by this warranty. **NO OTHER WARRANTIES ARE EXPRESSED OR IMPLIED, INCLUDING BUT NOT LIMITED TO THE IMPLIED WARRANTIES OF MERCHANTABILITY AND FITNESS FOR A PARTICULAR PURPOSE. HEWLETT-PACKARD IS NOT LIABLE FOR CONSEQUENTIAL DAMAGES.**

If this product is sold as part of a Hewlett-Packard integrated instrument system, the above warranty shall not be applicable, and this product shall be covered only by the system warranty.

Service contracts or customer assistance agreements are available for Hewlett-Packard products.

For any assistance, contact your nearest Hewlett-Packard Sales and Service Office. Addresses are provided at the back of this manual.

TABLE OF CONTENTS

Section	Page	Section	Page
I. GENERAL INFORMATION	1-1	V. MAINTENANCE.	5-1
1-1. Introduction.	1-1	5-1. Introduction.	5-1
1-3. Specifications	1-1	5-3. Test Equipment	5-1
1-6. Description	1-1	5-5. Warm-Up Period	5-1
1-9. Options	1-1	5-7. Introduction.	5-1
1-12. Accessories Supplied	1-4	5-9. Harmonic Distortion	5-1
1-14. Accessories Available	1-4	5-11. Signal to Phase Noise.	5-2
1-16. Instrument and Manual Identification	1-4	5-13. Spurious	5-3
		5-15. Amplitude Accuracy (Absolute)	5-4
		5-17. Frequency Response (3330A and 3330B with 10 dB Attenuator in Straight-Through Position)	5-4
II. INSTALLATION AND INTERFACING	2-1	5-19. 3330B Attenuator Accuracy (10 kHz)	5-5
2-1. Introduction.	2-1	5-21. 3330B Output Attenuator Frequency Response	5-6
2-3. Initial Inspection	2-1	5-23. Sweep Output	5-8
2-5. Power Requirements	2-1	5-25. Introduction.	5-11
2-7. Grounding Requirements	2-1	5-27. Power Supply.	5-11
2-9. Environmental Requirements.	2-1	5-29. Reference Oscillator	5-11
2-11. Repackaging for Shipment	2-2	5-31. Sweep.	5-11
2-15. Power Cords and Receptacles.	2-2	5-33. ÷ N Loop	5-11
2-17. Interfacing	2-2	5-35. SL Loop	5-12
		5-37. Amplitude Reference (3330B).	5-12
		5-39. Output Mixer Balance	5-13
		5-41. Amplitude.	5-13
III. OPERATING INSTRUCTIONS	3-1	Section	Page
3-1. Introduction.	3-1	VI. REPLACEABLE PARTS	6-1
3-3. Power—Warm Up.	3-1	6-2. Introduction.	6-1
3-5. Operation	3-1	6-4. Ordering Information.	6-1
3-7. Frequency	3-1	6-6. Non-Listed Parts	6-1
3-9. Frequency Step	3-2	Section	Page
3-11. Amplitude.	3-3	VII. CIRCUIT DIAGRAMS	7-1
3-13. Amplitude Step (3330B only)	3-3	7-1. Introduction.	7-1
3-15. Frequency and Amplitude Sweep.	3-4	7-3. Troubleshooting	7-1
3-17. Inputs and Outputs	3-6	7-7. Functional Block Diagram.	7-1
3-19. Remote Hewlett-Packard Interface Bus (HP-IB) Programming.	3-9	7-9. Schematic Diagrams.	7-1
3-24. Special Connectors	3-10	Section	Page
3-30. Switching Transients	3-12	VIII. BACKDATING.	8-1
3-31. Frequency Switching.	3-12	8-1. Introduction.	8-1
3-33. Amplitude Switching.	3-12	8-4. Backdating Changes	8-1
		8-5. Change No. 1 for 3330A Serial Numbers 1145A00112 and Lower; 3330B Serial Numbers 1144A00135 and Lower	8-1
IV. THEORY OF OPERATION	4-1	8-6. Change No. 2 for 3330A Serial Numbers 1145A00112 and Lower; 3330B Serial Numbers 1144A00210 and Lower	8-1
4-1. Introduction.	4-1	8-7. Change No. 3 for 3330A Serial Numbers 1145A00122 and Lower; 3330B Serial Numbers 1144A00260 and Lower	8-1
4-3. General Description	4-1		
4-5. Basic Block Description	4-1		
4-7. Reference Oscillator	4-1		
4-11. Frequency Generation	4-1		
4-20. Output Section.	4-4		
4-26. Digital Section	4-5		
4-31. Control Circuits	4-6		
4-33. Controller	4-6		
4-43. Clock Generator	4-9		
4-45. Control Processing Unit	4-9		
4-55. Input Circuits.	4-12		
4-60. Output Circuits	4-12		

TABLE OF CONTENTS (Cont'd)

Section	Page	Section	Page
8-8.	Change No. 4 for 3330A Serial Numbers 1145A00122 and Lower; 3330B Serial Numbers 1305A00360 and Lower . . .	8-14.	Change No. 10
	8-1	8-15.	Change No. 11 for 3330A Serial Numbers 1301A00203 and Lower; 3330B Serial Numbers 1313A01021 and Lower . . .
8-9.	Change No. 5 for 3330A Serial Numbers 1145A00128 and Lower; 3330B Serial Numbers 1313A00445 and Lower . . .		8-2
	8-1	8-16.	Change No. 12 for 3330B Serial Numbers 1313A01160 and Lower.
8-10.	Change No. 6 for 3330A Serial Numbers 1145A00132 and Lower; 3330B Serial Numbers 1313A00485 and Lower . . .		8-2
	8-1	8-17.	Change No. 13 for 3330B Serial Numbers 1313A01255 and Lower.
8-11.	Change No. 7 for 3330A Serial Numbers 1301A00152 and Lower; 3330B Serial Numbers 1313A00460 and Lower . . .		8-2
	8-1	8-18.	Change No. 14 for 3330A and for 3330B Serial Numbers 1313A01305 and Lower
8-12.	Change No. 8 for 3330A Serial Numbers 1301A00152 and Lower; 3330B Serial Numbers 1313A00610 and Lower . . .		8-2
	8-1		
8-13.	Change No. 9 for 3330A Serial Numbers 1301A00162 and Lower; 3330B Serial Numbers 1313A00610 and Lower . . .		
	8-1		

CODE LIST OF MANUFACTURERS
SALES AND SERVICE OFFICES

LIST OF TABLES

Table	Page	Table	Page
1-1.	Specifications	5-3.	3330B Frequency Response Specifications.
	1-1		5-7
1-2.	General Information	5-4.	Output Attenuator
	1-2		5-7
3-1.	3330A/B HP-IB Programming Codes	5-5.	Sweep Output Accuracy
	3-9		5-8
3-2.	Addressing Codes	6-1.	Replaceable Parts
	3-10		6-1
4-1.	Keyboard Output Codes	7-1.	Assembly Identification and Location
	4-6		7-2
4-2.	Display Signal Levels	7-2.	Table of Symptoms
	4-7		7-3
4-3.	Partial Bit List for A8U1.	7-3.	Integrated Circuit Information.
	4-7		7-69
4-4.	ALU Functions.	7-4.	Mnemonic Dictionary of Instructions and Qualifiers.
	4-11		7-75
5-1.	Test Equipment Required	7-5.	ROM Bit Lists.
	5-0		7-79
5-2.	Attenuator Accuracy Tolerances		
	5-6		

LIST OF ILLUSTRATIONS

Figure	Page	Figure	Page
2-1. Voltage Selection	2-1	7-7. Display A3A, A3B	7-25/7-26
2-2. Power Cords	2-2	7-8. N4 VTO A10	7-27/7-28
3-1. AM In	3-8	7-9. N3 VTO A12, N2 VTO A14	7-29/7-30
3-2. HP-IB Remote Input	3-10	7-10. N4 Counter/Sampler A9, N3 Counter/ Sampler A11, N2 Counter/Sampler A13	7-31/7-32
3-3. Addressing Jumpers	3-10	7-11. N1 VTO A16	7-33/7-34
3-4. HP-IB Timing Diagram	3-11	7-12. N1 Counter/Sampler A15	7-35/7-36
3-5. Special N4 Loop and SL3 Loop Connectors	3-11	7-13. SL2 Mixer/Phase Detector A21, SL3 Mixer/ Phase Detector A27	7-37/7-38
3-6. Special Mixer Input Connector	3-11	7-14. SL3 VTO A20, SL2 VTO A22	7-39/7-40
3-7. Simplified Block Diagram of Frequency Generating Circuits	3-12	7-15. SL1 Phase Detector A23, SL1 Mixer A24	7-41/7-42
3-8. Frequency Switching Transients	3-13	7-16. SL1 VTO A25	7-43/7-44
3-9. Amplitude Switching Transients	3-13	7-17. Output Mixer A30	7-45/7-46
4-1. Reference Oscillator	4-1	7-18. Attenuator A31 (standard, 75 ohm) Output Amplifier A32A (standard, 75 ohm) Output Amplifier A32B	7-47/7-48
4-1. Simplified Block Diagram	4-1	7-19. Amplitude Reference A26	7-49/7-50
4-3. Basic Block Diagram	4-2	7-20. Amplitude Detector/ Comparator A23	7-51/7-52
4-4. ÷ Loop	4-3	7-21. Amplitude Modulator A29A	7-53/7-54
4-5. SL Loop	4-4	7-22. Amplitude Modulator A29B	7-55/7-56
4-6. 3330A Amplitude	4-4	7-23. Ref Freq Sampler A18, Reference Oscillator A33	7-57/7-58
4-7. Simplified Amplitude Reference	4-5	7-24. Ref Freq Sampler A18, Reference Oscillator A33	7-59/7-60
4-8. 3330B Amplitude	4-6	7-25. 20 MHz VCXO A17	7-61/7-62
4-9. Slide Switch Strobe Timing Diagram	4-6	7-26. Sweep Generator A19, Remote Input/Output A34	7-63/7-64
4-10. Simplified ROM Diagram	4-7	7-27. Power Supply A35, Power Supply A36A, Power Supply A36B	7-65/7-66
4-11. Basic ROM Address	4-8	7-28. Attenuator A31 Output Amplifier A32A/B (Option 005, 5 V rms)	7-67/7-68
4-12. Flowchart Example	4-8	7-29. Controller Block Diagram	7-93
4-13. Inhibit Instructions	4-8	7-30. Logic Input Assembly, A6 Standard	7-95
4-14. Address Selection	4-9	7-31. Logic Input Assembly, A6 Option 004	7-97
4-15. Clock Generator	4-10	7-32. Control Assembly, A8	7-99/7-100
5-1. Harmonic Distortion	5-2	7-33. CPU, A7	7-101/7-102
5-2. Signal to Phase Noise	5-2	7-34. Logic Output Assembly, A5	7-103/7-104
5-3. 3330 Output Section	5-3	7-35. Controller Flowchart (1 of 5)	7-105/7-106
5-4. Spurious	5-4	7-36. Controller Flowchart (2 of 5)	7-107/7-108
5-5. Frequency Response	5-5	7-37. Controller Flowchart (3 of 5)	7-109/7-110
5-6. 3330B Attenuator Accuracy	5-6	7-38. Controller Flowchart (4 of 5)	7-111/7-112
5-7. 75 Ohm to 50 Ohm Adapter	5-9	7-39. Controller Flowchart (5 of 5)	7-113/7-114
5-8. Top and Bottom View	5-10	8-1. Keyboard A1A, A1B Slide Switch A2A, A2B Serial Numbers 1313A01305 and Lower	8-5/8-6
6-1. Chassis Mounted Components	6-47		
6-2. Main Assembly Mechanical Parts	6-50		
6-3. Front Panel Mechanical Parts	6-51		
6-4. Rear Panel Mechanical Parts	6-51		
7-1. Reference Frequency Troubleshooting Tree	7-5/7-6		
7-2. Controller Troubleshooting	7-7/7-8		
7-3. Frequency Generating Troubleshooting Tree	7-13		
7-4. Amplitude Troubleshooting Tree	7-17/7-18		
7-5. Functional Block Diagram and Schematic Notes	7-21/7-22		
7-6. Keyboard A1A, A1B Slide Switch A2A, A2B	7-23/7-24		

SECTION I

GENERAL INFORMATION

1-1. INTRODUCTION.

1-2. This section contains general information about the -hp- Model 3330A/B Automatic Synthesizer. A general description plus information on specifications, accessories, and instrument identification is given.

1-3. SPECIFICATIONS.

1-4. Table 1-1 is a complete list of the Model 3330A/B critical specifications that are controlled by tolerances. Table 1-2 contains general information that describes the operating characteristics of the 3330A/B.

1-5. Any change in the specifications due to manufacturing, design, or traceability to the U.S. National Bureau of Standards will be covered by a manual change sheet. This manual and manual change sheet supersede all previous information concerning specifications of the 3330A/B.

1-6. DESCRIPTION.

1-7. The -hp- Model 3330A/B Automatic Synthesizer provides accurate and stable frequencies from 0.1 Hz to 13,000,999.9 Hz with a resolution of 0.1 Hz. Digital sweeping of frequency is standard on both the 3330A and 3330B. Selection of frequency and frequency sweep is accomplished by a front panel keyboard.

1-8. With the 3330A, the output amplitude is selected by a 0-13 dBm potentiometer. Maximum output voltage for both the 3330A and 3330B is 1 V rms into 50 ohms. The 3330B output amplitude is selected by the front panel keyboard. Output amplitude capability is +13.44 dBm to -86.55 dBm with a resolution of 0.01 dB. Digital sweeping of amplitude is also available on the 3330B.

1-9. OPTIONS.

1-10. The following options are available with the 3330A/B Synthesizer.

Option	
001	75 ohm, 1 V rms, output
002	High stability Crystal Oven
003	Deletion of Crystal Oven
004	Isolated Digital Input
005	5 V rms into 50 ohm Output Power Amplifier
908	Rack Mounting Kit
910	Additional Operating and Service Manual

1-11. For more information concerning these options, contact your local -hp- Sales and Service Office, listed in Appendix B of this manual.

Table 1-1. Specifications.

3330A/B FREQUENCY SECTION	3330A AMPLITUDE SECTION
<p>Frequency Stability. Long term: $\pm 1 \times 10^{-8}$ per day $\pm 1 \times 10^{-7}$ per month</p> <p>Temperature: 20°C to 30°C: $\pm 1 \times 10^{-8}$ of frequency at 25°C. 0°C to 55°C: $\pm 1 \times 10^{-7}$ of frequency at 25°C.</p> <p>Signal to phase noise (integrated): > 50 dB down in a 30 kHz band, excluding ± 1 Hz centered on carrier.</p> <p>Harmonic Distortion. With full output amplitude, any harmonically related signal will be less than the following specified levels: - 60 dB with output from 5 Hz to 100 kHz - 50 dB with output from 100 kHz to 1 MHz - 40 dB with output from 1 MHz to 13 MHz</p> <p>Spurious. 3330A: > 70 dB below selected output. 3330B: > 70 dB below selected output or less than - 110 dBm/50 Ω, whichever is greater.</p>	<p>Amplitude. Maximum 2 Vrms $\pm 10\%$ open circuit. Maximum 1 Vrms $\pm 10\%$ into 50 ohms.</p> <p>Frequency Response (10 kHz Reference): ± 0.5 dB over total range.</p> <p style="text-align: center;">3330B AMPLITUDE SECTION</p> <p>Amplitude (10 kHz Reference, 25°C \pm 5°C + 13.44 dBm). 2.1 V rms open circuit $\pm 0.5\%$ (± 0.05 dB) 1.05 V rms into 50 ohms $\pm 0.5\%$ (± 0.05 dB).</p> <p>Attenuator Accuracy (10 kHz Reference): ± 0.02 dB/10 dB step.</p> <p>Sweep Output Stepped dc voltage proportional to sweep position of frequency or amplitude, 0 to + 10 V. Accuracy: $\pm 0.2\%$ of full scale Linearity: $\pm 0.1\%$ of full scale</p>

Table 1-1. Specifications. (Cont'd).

3330B AMPLITUDE SECTION (Cont'd)

Frequency Response (10 kHz Reference).

3330B Attenuator Setting (dBm)			Specification (dB)	
Standard	Option 001	Option 005	* Leveling OFF	Leveling SLOW (>10 Hz) or Leveling FAST (>1 kHz)
+ 13.44 to - 16.55	+ 11.68 to - 18.31	+ 26.99 to - 3.00	± 0.5	± 0.05
- 16.55 to - 36.55	- 18.31 to - 38.31	- 3.00 to - 23.00	± 0.5	± 0.10
- 36.55 to - 66.55	- 38.31 to - 68.31	- 23.00 to - 53.00	± 0.5	± 0.20
- 66.55 to - 86.55	- 68.31 to - 88.31	- 53.00 to - 73.00	± 0.5	± 0.40

*For frequencies above 10 Hz and Leveling in OFF position, add 0.5 dB to Leveling SLOW (>10 Hz) or Leveling FAST (>1 kHz) specification.

Table 1-2. General Information.

3330A/B FREQUENCY SECTION	Largest digit changed	0.1 Hz or 1 Hz	10 Hz or 100 Hz	1 kHz or 10 kHz	100 kHz, 1 MHz or 10 MHz
	<p>Frequency Range: 0.1 Hz to 13,000,999.9 Hz</p> <p>Frequency Resolution: 0.1 Hz (8 digits + overrange).</p> <p>Internal Frequency Reference. 5 MHz crystal in temperature stabilized oven. Optional higher stability crystal oven (Option 002) or lower stability 20 MHz ambient temperature crystal (Option 003) references available.</p> <p>Frequency Reference Adjustments (5 MHz VCXO). Coarse: Internal adjustment adequate for 5 years of aging. Fine: 1 turn potentiometer on rear panel or ± 5 Vdc applied to REF TUNE IN and REF OSC switch in INT position: - 5 V: -.7 to -1.5 x 10⁻⁷ of value at 0 V + 5 V: +.5 to 1 x 10⁻⁷ of value at 0 V REF OSC switch in EXT position and no external reference applied: 20 to 40 ppm total adjustment range</p> <p>External Frequency Reference The 3330A/B may be phase locked with a 200 mV rms to 2 V rms signal that is any subharmonic of 20 MHz from 1 MHz through 10 MHz (i.e., 1 MHz, 2 MHz, 2.5 MHz, 5 MHz, 10 MHz). BNC female connector.</p> <p>Frequency switching and settling time: the time required for frequency switching and settling is a function of the largest frequency digit affected by the frequency change in question.</p>	<1 ms to within 500 µHz	<1 ms to within 0.05 Hz	<1 ms to within 5Hz: <50 ms to within 0.01 Hz	<1 ms to within 500 Hz: <50 ms to within 1 Hz
3330A AMPLITUDE SECTION					
Amplitude Range: 0 dBm to + 13 dBm, front panel control					
Output Impedance: 50 ohm (75 ohm Option 001)					
Amplitude Modulation External modulation source required, rear panel BNC. DC to 100 kHz signal, 0.95 V rms for 95% modulation depth (0.01 V rms/1% depth).					
3330B AMPLITUDE SECTION					
Amplitude Range: + 13.44 dBm to - 86.55 dBm into 50 ohms.					
Amplitude Resolution: 0.01 dB					
Output Impedance: 50 ohm (75 ohm Option 001)					

Table 1-2. General Information.(Cont'd)

<p>Display. Four digit readout in dBm referenced to 50 ohm. Display referenced to other impedances on special basis or internally adjustable by user to compensate for external attenuation or amplification.</p> <p>Amplitude Modulation. External modulation source required, rear panel BNC. 100 Hz to 100 kHz, 0.95 V rms for 95% modulation depth. LEVELING control must be in SLOW (> 10 Hz) position.</p> <p style="text-align: center;">DIGITAL REMOTE CONTROL</p> <p>All front panel controls with the exception of POWER and 3330A AMPLITUDE are programmable. Programming instructions are in a seven bit parallel ASCII code. Each control has an ASCII code assigned to it.</p> <p>Timing: Maximum of 310 μsec per digit to enter digits of frequency or amplitude. Maximum of 1 msec to enter and initiate program control codes. Maximum of 2.5 msec to enter and initiate sweep or calculate and output FIRST POINT.</p> <p>Input Control Lines: 7 "program data" lines</p> <p>1 "remote enable" line 1 "data valid" line</p> <p>Output Control Lines: 1 "not ready for data" line 1 "data not accepted" line</p> <p>Isolation: Isolation of the input and output control line grounds with respect to the 3330A/B output signal ground is available with Option 004.</p> <p>Logic Level Requirements:</p> <table border="0" style="width: 100%;"> <thead> <tr> <th style="text-align: left;">State</th> <th style="text-align: left;">Requirements</th> </tr> </thead> <tbody> <tr> <td>"Low" (Logical "1")</td> <td>0 V to 0.4 V (5 mA max) or contact closure to ground through < 80 ohms</td> </tr> <tr> <td>"High" (Logical "0")</td> <td>2.4 V to 5 V or removal of contact closure to ground</td> </tr> </tbody> </table> <p>Outputs. Rear panel output: Rerouting of internal cable from front panel output to rear panel ALT OUTPUT female TRIAX connector yields rear panel output. No degradation of performance for rear panel output. Auxiliary Output: 20 to 33 MHz tracking output that is always 20 MHz above front panel output available at rear panel female BNC connector. Voltage is > 100 mV rms/50 ohms. 1 MHz sine wave reference output is available at rear panel female BNC connector. Voltage is > 220 mV rms/50 ohms. Digital Output: Digital signals available at rear of instrument to indicate various frequency or amplitude sweep parameters. Includes: Step Count: 0 to 1000 count on 12 BCD (8-4-2-1) lines to indicate sweep position. (e.g., count of 500 indicates center frequency or amplitude). Sweep Status: One line to indicate when instrument is sweeping. Step Ready: One line indicates the instrument has spent the selected time per step and is ready to go to the next step. Step Inhibit: One line which, when grounded, stops sweep on that step.</p>	State	Requirements	"Low" (Logical "1")	0 V to 0.4 V (5 mA max) or contact closure to ground through < 80 ohms	"High" (Logical "0")	2.4 V to 5 V or removal of contact closure to ground	<p>Sweep. Digital sweeping of both frequency and amplitude in the 3330B and frequency in the 3330A. When sweeping frequency automatically, the total sweep width may be as large as the entire frequency range or as small as 1 Hz. When sweeping amplitude automatically, the total sweep width may be as large as the entire amplitude range or as small as 0.1 dB. When sweeping frequency, each step of the frequency has the same stability as the frequency reference.</p> <p style="text-align: center;">GENERAL</p> <p>Operating Temperature: 0°C to + 55°C</p> <p>Storage Temperature: - 40°C to + 70°C</p> <p>Turn on Time: Application of power to "On": < 20 min to within $\pm 1 \times 10^7$ of the final frequency. "Standby" to "On": < 15 seconds to full specifications.</p> <p>Power requirements. 115 V or 230 V $\pm 10\%$, 48 Hz to 66 Hz, (400 Hz line frequency operation on special basis). < 20 W standby, < 200 W on.</p> <p>Weight 3330A: 49 lb (22.1 kg). shipping 58 lb (26.4 kg). 3330B: 53 lb (24.0 kg). shipping 63 lb (28.6 kg).</p> <p>Dimensions: 16 3/4 in. wide x 7 in. high x 21 1/2 in. deep) (426 x 178 x 547 mm)</p> <p>Options</p> <p style="text-align: center;">75 Ohm - 1 V rms Output Power Amplifier Option 001 (Factory installation only)</p> <p>Attenuation and output referenced to 75 ohm. Amplitude range 3330A: + 11.3 dBm to - 1.7 dBm 3330B: + 11.68 to - 88.31 dBm</p> <p style="text-align: center;">High Stability Crystal Oven Option 002*</p> <p>10 MHz crystal reference in temperature stabilized oven. Frequency stability: Long term: $\pm 1 \times 10^{-9}$ per day $\pm 2 \times 10^{-8}$ per month Temperature: 20°C to 30°C $\pm 1 \times 10^{-9}$ of frequency at 25°C. 0°C to + 55°C: $\pm 1 \times 10^{-8}$ of frequency at 25°C.</p> <p>Physical orientation: 5×10^{-8} total change in frequency for any physical orientation of instrument with respect to gravity.</p> <p>Frequency adjustments: same as standard instrument.</p> <p>*Field installable - order -hp- Accessory 11452A.</p> <p style="text-align: center;">Deletion of Crystal Oven Option 003*</p> <p>20 MHz ambient temperature crystal reference oscillator. Recommended for applications where only moderate frequency stability is needed or where the 3330A/B is to use an external reference.</p>
State	Requirements						
"Low" (Logical "1")	0 V to 0.4 V (5 mA max) or contact closure to ground through < 80 ohms						
"High" (Logical "0")	2.4 V to 5 V or removal of contact closure to ground						

Table 1-2. General Information. (Cont'd)

<p>Frequency stability: ± 10 parts in 10^6 yr. Frequency adjustments: rear panel 1 turn pot or rear panel voltage control input for 40×10^{-6} maximum control.</p> <p>*Standard Crystal Oven can be installed later - order -hp- Part Number 0410-0457.</p>	<p>5 V RMS - 50 Ohm Output Power Amplifier Option 005*</p> <p>This option gives the 3330A/B a 1/2 watt output. (5 volts rms into 50 ohms or 10 volts rms into an open circuit.)</p>
<p>Isolated Digital Input Option 004 (Factory installation only)</p> <p>With this option, the digital input lines are electrically isolated from the signal ground.</p> <p>DC Isolation ± 250 V AC Isolation > 30 dB, 0 to 1 MHz</p>	<p>Amplitude range</p> <p>3330A: + 27 dBm to + 14 dBm into 50 ohms 3330B: + 26.99 dBm to - 73 dBm into 50 ohms</p> <p>*For field installation - order -hp- Accessory 11455A (A model) 11455B (B model)</p>

1-12. ACCESSORIES SUPPLIED.

1-13. Accessories supplied with the 3330A/B are as follows:

- One HP-IB Adapter, -hp- Part No. 11235A
- One Extender Board, -hp- Part No. 03330-66534
- One Extender Board, -hp- Part No. 03330-66535
- One Extender Board, -hp- Part No. 03330-66588

1-14. ACCESSORIES AVAILABLE.

1-15. Accessories available for the 3330A/B are as follows:

- | | |
|-----------|--|
| 11236B | Interfacing Cable |
| 11451A | Optional Interface Cable Kit |
| 11452A | Hi Stability Oven, Option 002 |
| 11455A | 5 V-50 Ω Output Option 005, 3330A |
| 11455B | 5 V-50 Ω Output Option 005, 3330B |
| 5060-8744 | Rack Mounting Kit |

10631A/B/C HP-IB Cables

11048C 50 Ω Feedthrough (precision)

11094C 75 Ω Feedthrough (precision)

1-16. INSTRUMENT AND MANUAL IDENTIFICATION.

1-17. Hewlett-Packard uses a two-section serial number. The first section (prefix) identifies a series of instruments. The last section (suffix) identifies a particular instrument within the series. If a letter is included with the serial number, it identifies the country where the instrument was manufactured. This manual is kept up-to-date with the instrument by a manual change sheet. If the serial prefix of your instrument differs from the one on the title page of this manual, refer to Section VIII for backdating information that will adapt this manual to your instrument. All correspondence with Hewlett-Packard should include the complete serial number.

SECTION II INSTALLATION AND INTERFACING

2-1. INTRODUCTION.

2-2. This section contains information and instructions for the installation and shipping of the 3330A/B. Included are initial inspection procedures, power and grounding requirements, environmental information, repackaging for shipment, and interfacing.

2-3. INITIAL INSPECTION.

2-4. This instrument was carefully inspected both mechanically and electrically before shipment. It should be free of marks or scratches and in perfect electrical order upon receipt. To confirm this, the instrument should be inspected for physical damage in transit, and the electrical performance should be tested using the performance tests outlined in Paragraph 5-7. If there is damage or deficiency, see the warranty inside the front of this manual.

2-5. POWER REQUIREMENTS.

2-6. The 3330A/B operates from an ac power source of 48 to 66 Hz at the following voltages:

115 V + 5% - 10%
230 V + 5% - 10%

The 3330A/B is normally set for 115 V operation at the factory. Refer to Figure 2-1 for the procedure to change your instrument for operation on 230 V.

2-7. GROUNDING REQUIREMENTS.

2-8. To protect operating personnel, the National Electrical Manufacturers' Association (NEMA) recommends that the instrument panel and cabinet be grounded. The Model 3330A/B is equipped with a three-conductor power cable which, when plugged into an appropriate receptacle, grounds the instrument. The offset pin on the power cable is the ground wire.

WARNING

Your instrument is equipped with a power cord which grounds it when connected to a 3 contact grounded receptacle. Do not attempt to defeat this feature.

2-9. ENVIRONMENTAL REQUIREMENTS.

2-10. The 3330A/B is equipped with a cooling fan mounted on the rear panel. The instrument should not be mounted in any manner which would obstruct the flow of air through the instrument. The filter for the cooling fan can be removed and cleaned by flushing with soapy water. The 3330A/B should not be operated where the ambient temperature exceeds 0°C to 55°C (32°F to 131°F) or stored where the ambient temperature exceeds -40°C to 70°C (-40°F to 158°F).

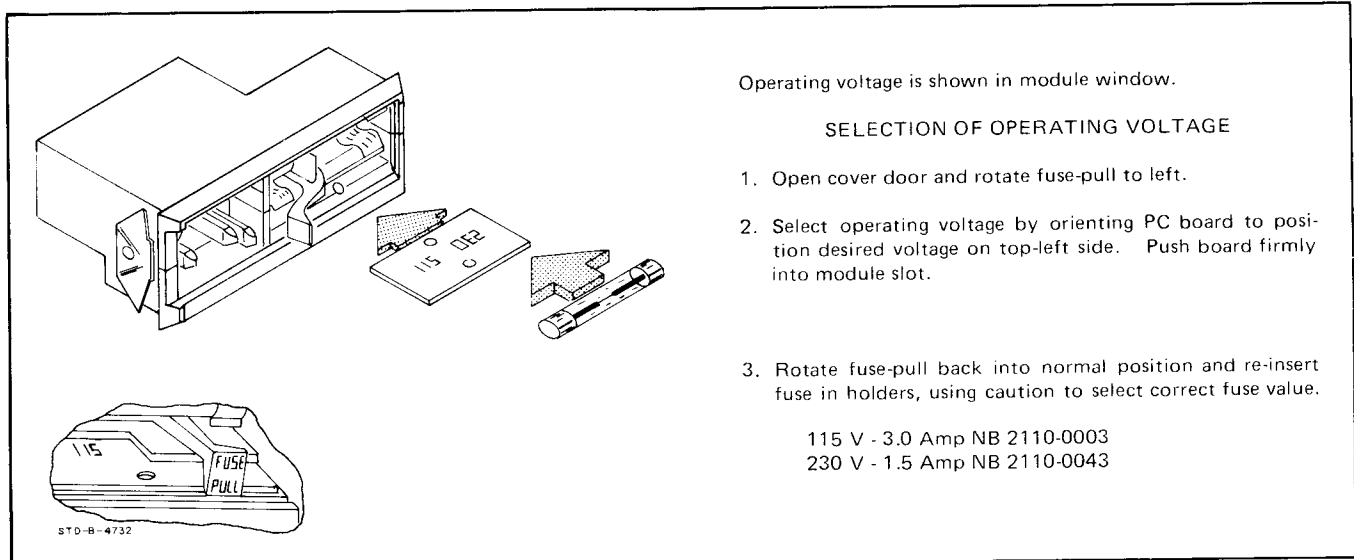

Figure 2-1. Voltage Selection.



WHEN MOUNTING THE 3330A/B IN AN INSTRUMENT RACK, CARE SHOULD BE TAKEN TO SUPPORT THE REAR OF THE INSTRUMENT. FAILURE TO DO SO MAY CAUSE DAMAGE TO THE INSTRUMENT.

2-11. REPACKAGING FOR SHIPMENT.

2-12. The following paragraphs contain a general guide for repackaging the instrument for shipment. Refer to Paragraph 2-13 if the original container is to be used; 2-14 if it is not. If you have any questions, contact your nearest -hp- Sales and Service Office (see Appendix B for office locations).

NOTE

If the instrument is to be shipped to Hewlett-Packard for service or repair, attach a tag to the instrument identifying the owner and indicating the service or repair to be accomplished. Include the model number and full serial number of the instrument. In any correspondence, identify the instrument by model number and full serial number.

2-13. Place instrument in original container with appropriate packing material and seal well with strong tape or metal bands. If original container is not available, one can be purchased from your nearest -hp- Sales and Service Office.

2-14. If original container is not to be used, proceed as follows:

- a. Wrap instrument in heavy paper or plastic before placing in an inner container.
- b. Place packing material around all sides of instrument and protect panel face with cardboard strips.

c. Place instrument and inner container in a heavy carton or wooden box and seal with strong tape or metal bands.

2-15. POWER CORDS AND RECEPTACLES.

2-16. Figure 2-2 illustrates the standard power cord configurations that are used throughout the United States and in other countries. The -hp- part number shown directly below each drawing is the part number for a 3330A/B power cord equipped with the appropriate mating plug for that receptacle. If the appropriate power cord is not included with the instrument, notify the nearest -hp- Sales and Service Office and a replacement cord will be provided. The 3330A/B power cord, power input receptacle and mating connectors meet the safety standards set forth by the International Electrotechnical Commission (IEC).

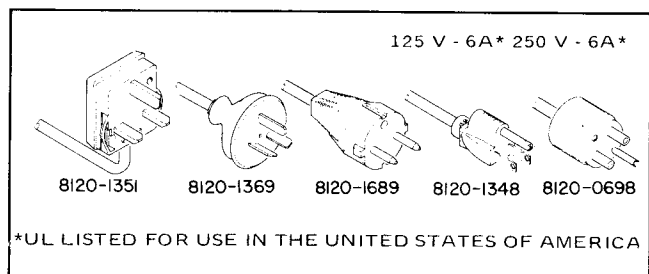

Figure 2-2. Power Cords.

2-17. INTERFACING.

2-18. The 3330A/B can be remotely programmed by any ASCII coded source. Section III, Paragraph 3-19, describes the remote input connector and signal requirements. Logic level requirements are listed in Table 1-2 (General Information). Several HP-IB programmable units can be paralleled together on the same HP-IB lines with the use of the 11236B interface cable, or an HP-IB adapter, 11235A, used with an HP-IB cable, 10631A, B, or C.

SECTION III OPERATING INSTRUCTIONS

3-1. INTRODUCTION.

3-2. This section contains information and instructions necessary for operation of the -hp- Model 3330A/B Automatic Synthesizer. Included is power and warm up information; functional identification of all indicators, controls and connectors; front panel programming information; remote programming information; and special applications information.

3-3. POWER - WARM UP.

3-4. The 3330A/B can be operated from any source of 115 V \pm 10% or 230 V \pm 10% at 48 to 66 Hz. The power receptacle on the rear panel contains the switch for selecting 115 V or 230 V and the input power fuse. The instrument leaves the manufacturer with the switch in the 115 V position. It is necessary to set the 115 V/230 V switch to the 230 V position when operating from a 230 V source. The 3330A/B has a two position (standby and on) power control on the front panel. The instrument takes <15 seconds to reach full specification from the STBY position to the ON position. The instrument takes <20 minutes to reach $\pm 1 \times 10^{-7}$ of full frequency specifications from the application of external power to the ON position.

3-5. OPERATION.

3-6. Front panel operation of the 3330A/B requires selecting keyboard and slide switch controls in various sequences for desired modes of operation. The following explanations divide the controls into their functional descriptions (frequency, frequency step, amplitude, amplitude step, sweep) and their programming sequence. When the 3330A/B is initially turned on, the conditions set on the display and at the output are:

```

Frequency ..... 0.0 Hz
Amplitude ..... - 86.55 dBm
                    (Std. Instr. Only)
Frequency Step ..... 0.0 Hz
Amplitude Step ..... 0.00 dBm
Sweep ..... off *
    
```

* Sweep parameters are as set on sweep slide switches.

3-7. Frequency.

3-8. The frequency range of the 3330A/B is 0 Hz to 13000999.9 Hz with a 0.1 Hz resolution. The controls used to program a desired frequency (in the sequence they are selected) are FREQ, 0 through 9 digit keys, and Hz, KHz, or MHz range keys. A description of each control and indicator follows.

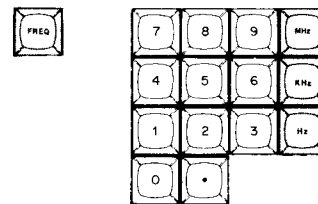
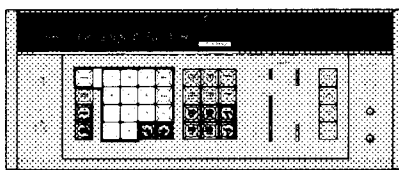

Controls:



Preface key for entering frequency. The FREQ key can be pressed at any time to recall the previous frequency entry.

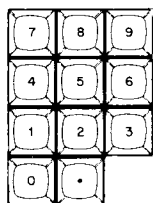

Digit keys. These keys are used to enter the desired frequency digits.



Range keys. Three ranges are available (MHz, KHz, and Hz). These keys complete the programming of a frequency. The frequency desired is displayed and applied to the 3330A/B output.

Indicators:



Indicates that the digits displayed directly to right of indicator are frequency.



Indicates the desired frequency selected. Digits are entered from right as frequency digit keys are pressed. Display is always in Hz. When Range key is selected, the decimal point is automatically placed for a Hz readout. Any digit below the tenth Hz digit is automatically rejected by the 3330A/B.



Error indicator. Indicates a programming error has been made. Selected program is out of range of the 3330A/B. OUT OF RANGE indicator also applies to frequency step, amplitude, and amplitude step. The 3330A/B will sweep, although the OUT OF RANGE indicator is lit, if the sweep starts from an in-range position. When the sweep reaches the out-of-range limit, the sweep holds until the last step of the sweep.

Example:

Program a frequency of 12345678.9 Hz.

Press **FREQ**

Press 1, 2, 3, 4, 5, 6, 7, 8, ., 9 digits.

Press **Hz**

3-9. Frequency Step.

3-10. The frequency step function is used when it is desired to sweep a certain range of frequencies or when it is desired to manually change the frequency by a specific amount. The controls used to program a frequency step (in the sequence they are selected) are **FREQ STEP**, 0 through 9 digit keys, and **Hz**, **KHz**, or **MHz** range keys. There are also six modifier keys which can be used to modify the programmed frequency or the programmed frequency step. A description of each control and indicator follows.

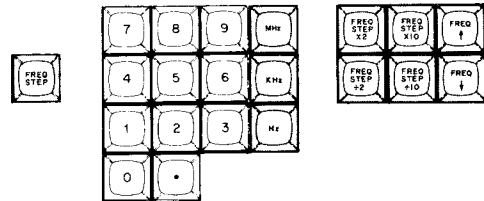
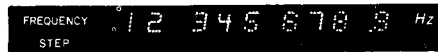
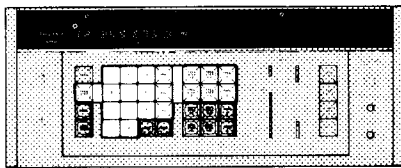

Controls:



Preface key for entering frequency step. The **FREQ STEP** key can be pressed at any time to recall the previous frequency step entry.

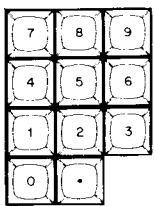

Digit keys. These keys are used to enter the desired frequency step digits. If the frequency step is used in conjunction with the Sweep function, it is necessary to consider the position of the **SWEEP STEPS** control in relation to the size of the frequency step (see Paragraph 3-15).



Range keys. Three ranges are available (Hz, KHz, and MHz). These keys complete the programming of the frequency step.

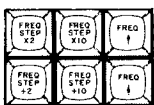

Frequency and frequency step modifier keys. These keys can be used to modify the frequency or frequency step. To modify the frequency, press the **FREQ ↑** or **FREQ ↓** key. The frequency will be changed up or down by the amount of the frequency step. If the **FREQ ↑** or **FREQ ↓** key is pressed and

held, the frequency will continue to change at the rate of the **TIME/STEP** (Paragraph 3-15) until the key is released. To modify the frequency step, press the **FREQ STEP x 2**, **FREQ STEP x 10**, **FREQ STEP ÷ 2**, or **FREQ STEP ÷ 10** key. The frequency step will be changed by the respective amount. Modification of frequency or frequency step can be made at any time. If made during the Sweep function, modification will occur at the end of each sweep.

Indicators:



Indicates that the digits displayed directly to right of indicator are frequency step.

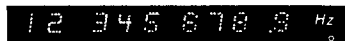

Indicates the desired frequency step selected. Digits are entered from right as frequency step digit keys are pressed. Display is always in Hz. When range key is pressed, the decimal point is automatically placed for a Hz readout. Any digit below the tenth Hz digit is automatically rejected by the 3330A/B.

Example:

Program a frequency of 5 MHz
and a frequency step of 1 MHz.

- Press **FREQ**
- Press 5 digit
- Press **MHz**
- Press **FREQ STEP**
- Press 1 digit
- Press **MHz**

3-11. Amplitude.

3-12. In the 3330A a 0 dBm to +13 dBm front panel potentiometer is used to select the desired amplitude level. In the 3330B, the front panel keyboard is used to select any amplitude level from -86.55 dBm to +13.44 dBm with a resolution of 0.01 dB. The controls used to program a desired amplitude (in the sequence they are selected) are **AMPL**, 0 through 9 digit keys, and +dBm or -dBm. A **LEVELING** switch is provided to control the flatness of the amplitude. A description of each control and indicator follows.

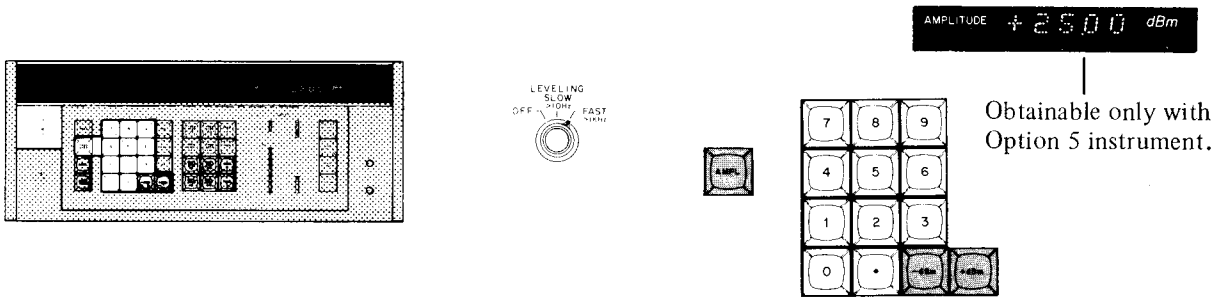

Controls: (3330B only)

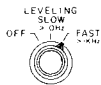

Amplitude level control. The frequency response of the 3330B is controlled by a thermopile in the amplitude section. The thermopile will respond to the peaks of the output sinewave if the programmed frequency is less than 10 Hz. To prevent this, the **LEVELING** control should be in the **OFF** position. This position removes the thermopile from the leveling loop. For frequencies between 10 Hz and 1 kHz additional filtering is added to eliminate the thermopile from reacting to the peaks of the output amplitude. For frequencies above 1 kHz, the additional filtering is removed to decrease the settling time of the output amplitude. *Do not use the **FAST** > 1 kHz position for frequencies less than 1 kHz or the **SLOW** > 10 Hz position for frequencies less than 10 Hz or the 3330B flatness and distortion specifications may be degraded.*



Preface key for entering amplitude. The **AMPL** key can be pressed at any time to recall the previous amplitude entry.

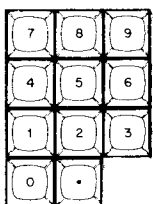

Digit keys. These keys are used to enter the desired amplitude digits.

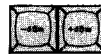

Amplitude polarity keys. These keys complete the programming of an amplitude. The amplitude desired is displayed and applied to the 3330B output.

Indicators: (3330B only)



Indicates that the digits displayed directly to right of indicator are amplitude.



Indicates selected amplitude digits. Digits are entered from right as amplitude digit keys are pressed.

Example:

- Program an amplitude of +12.34 dBm.
- Press **AMPL**
- Press 1, 2, ., 3, 4 digits
- Press + dBm

3-13. Amplitude Step (3330B only)

3-14. The amplitude step function is used when it is desired to sweep a certain range of amplitude or when it is desired to manually change the programmed amplitude by a specific amount. The controls used to program an amplitude step (in the sequence they are selected) are **AMPL STEP**, 0 through 9 digit keys, and -dBm or +dBm. There are also six modifier keys which can be used to modify the programmed amplitude or the programmed amplitude step. A description of each control and indicator follows.

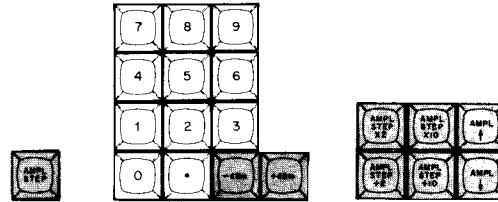
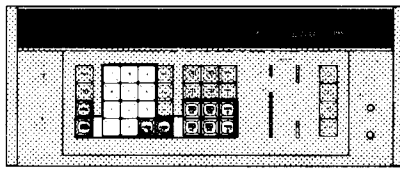

Controls:



Preface key for entering amplitude step. The AMPL STEP key can be pressed at any time to recall the previous amplitude step entry.

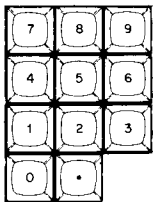

Digit keys. These keys are used to enter the desired amplitude step digits. If the amplitude step is used in conjunction with the Sweep function, it is necessary to consider the position of the SWEEP STEPS control in relation to the size of the amplitude step (see Paragraph 3-15).



Amplitude polarity keys. The polarity keys complete the programming of amplitude step.



Amplitude modifier keys. These keys can be used to modify the amplitude or the amplitude step. To modify the amplitude, press the AMPL ↑ or AMPL ↓ key. The amplitude will change by the amount of the amplitude step. If the AMPL ↑ or the AMPL ↓ is pressed and held, the amplitude will change at the rate of the TIME/STEP (Paragraph 3-15) until the key is released. To modify the amplitude step, press the AMPL STEP x 2, AMPL STEP x 10, AMPL STEP ÷ 2, or AMPL STEP ÷ 10 key. Modification of the amplitude or the amplitude step can be made at any time. If made during the sweep mode, the modification will occur at the end of each sweep cycle.

Indicators:



Indicates that the digits displayed directly to right are amplitude step.



Indicates selected amplitude step digits. Digits are entered from right as amplitude digit keys are pressed.

Example:

- Program an amplitude of - 30.00 dBm and an amplitude step of 5.00 dBm
- Press AMPL
- Press 3, 0 digits
- Press - dBm
- Press AMPL STEP
- Press 5 digit
- Press - dBm or + dBm

3-15. Frequency and Amplitude Sweep.

3-16. The 3330A/B frequency and the 3330B amplitude can be swept over a specific range. The sweep is a digital sweep which steps the frequency or amplitude to each point. The sweep controls include the function switch (FREQ, AMPL), direction switch (UP, DOWN, BOTH), SWEEP TIME/STEP switch, SWEEP STEPS, FIRST POINT, START SINGLE, and START CONT. To use the sweep mode, a frequency and a frequency step, or an amplitude and an amplitude step, must be programmed. In choosing the frequency or amplitude and the size of the frequency step or amplitude step, the frequency and amplitude limits of the 3330A/B should be considered along with the position of the SWEEP STEPS control. The number of steps chosen will be divided evenly on either side of the frequency or amplitude. If the frequency step or amplitude step is too large, the 3330A/B will OUT OF RANGE and the sweep will stop. Use the following formula to determine if the settings chosen will OUT OF RANGE the 3330A/B:

1. $A + \frac{B \times C}{2} = \leq 13.0009999 \text{ MHz}$
 $\leq + 13.44 \text{ dBm}$
2. $A - \frac{B \times C}{2} = \geq 0 \text{ Hz}$
 $\geq - 86.55 \text{ dBm}$

Where:

- A= f frequency or amplitude
- B = SWEEP STEPS
- C = frequency step or amplitude step

When sweeping frequency, 1/2 the total sweep width (formula 1 - formula 2) cannot exceed 10 MHz or the 3330A/B will OUT OF RANGE. A description of the controls used to program a desired sweep and the indicators used for sweep follows.



Controls:



Function switch: selects function of sweep.



Direction switch. Selects the direction of sweep. Used in conjunction with FIRST POINT to find the minimum and maximum frequency or amplitude. When in UP position, sweep starts at minimum frequency or amplitude and sweeps to maximum frequency or amplitude. When in DOWN position, sweep starts at maximum frequency or amplitude and sweeps to minimum frequency or amplitude. When in BOTH position, sweep starts at minimum frequency or amplitude, sweeps to maximum, and back to minimum.

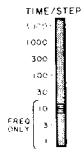

SWEEP TIME/STEP. Selects time for each step when sweeping or modifying frequency or amplitude. Can be changed during sweep.



SWEEP STEPS. Selects number of steps in each sweep. Must be considered when selecting frequency step or amplitude step.



Convenience key. This key, when used in conjunction with the SWEEP direction switch, causes the 3330A/B to display and output the starting point of the sweep selected. If the SWEEP direction switch is in the UP or BOTH position, the display and 3330A/B output will go to the minimum (starting point) frequency or amplitude in the sweep range. If the SWEEP direction switch is in the DOWN position, the display and 3330A/B output will go to the maximum (starting point) frequency or amplitude in the sweep range. If FIRST POINT key is pressed while the sweep is in progress, the sweep will stop. Display and 3330A/B output will go to the starting point of the sweep range.



Start key for single sweep. When pressed, 3330A/B will make one complete sweep.



Start key for continuous sweep. When pressed instrument will sweep the parameters selected until stopped.



Stop sweep key. Stops sweep and returns instrument display and output to center frequency or amplitude.

Indicators:



Indicates that the digits displayed directly to the right of CTR FREQUENCY indicator or CTR AMPLITUDE indicator are the frequency or amplitude digits selected. This indicator operates only when continuous sweep is in progress and the FREQ key or AMPL key has been pressed.



Indicates that the digits displayed directly to right of MIN or MAX FREQUENCY or MIN or MAX AMPLITUDE indicators are starting point digits of sweep. Display is dependent on SWEEP direction control and FIRST POINT key.



Indicates sweep is in operation. Function swept (frequency or amplitude) is indicated by an arrow. Only one arrow will be illuminated.

Example:

Program a continuous frequency sweep from 0 Hz to 25 kHz. Use maximum steps allowed. Set amplitude for +13.44 dBm.

Steps are divided equally on either side of frequency, therefore, frequency = 25 kHz ÷ 2 = 12.5 kHz.

Maximum SWEEP STEPS=1000, therefore, Frequency Step = 25 kHz ÷ 1000 = 25 Hz. To insure the sweep end points (MIN - MAX FREQUENCY) are not OUT OF RANGE:

$$A + \frac{B \times C}{2} = 12.5 \text{ kHz} + \frac{1000 \times 25 \text{ Hz}}{2} =$$

12.5 kHz + 12.5 kHz = 25 kHz =
MAX FREQUENCY.

$$A - \frac{B \times C}{2} = 12.5 \text{ kHz} - \frac{1000 \times 25 \text{ Hz}}{2} =$$

12.5 kHz - 12.5 kHz = 0 Hz =
MIN FREQUENCY.

- Set LEVELING to OFF
- Press FREQ
- Press 1, 2, ., 5 digits
- Press kHz
- Press FREQ STEP
- Press 2, 5 digits
- Press Hz
- Set SWEEP mode to FREQ
- Set SWEEP STEPS to 1000
- Set SWEEP TIME/STEP to desired time/step
- Set SWEEP direction to UP
- Press FIRST POINT. Display should indicate a MIN

- FREQUENCY of .0 Hz.
- Set SWEEP direction to DOWN
- Press FIRST POINT. Display should indicate a MAX FREQUENCY of 25000.0 Hz.
- Set SWEEP direction to desired position.
- Press AMPL
- Press 1, 3, ., 4, 4 digits
- Press + dBm
- Press START CONT for continuous sweep or START SINGLE for single sweep.

3-17. Inputs and Outputs.

3-18. The 3330A/B front and rear panel inputs and outputs include front panel SWEEP OUTPUT and 50 Ω OUTPUT; rear panel BCD OUTPUTS (optional), ALT OUTPUT, RF + 20 MHz OUT, 1 MHz OUT, REF TUNE IN, EXT REF IN, AM IN, REMOTE CONTROL. Explanations of these inputs and outputs are as follows:

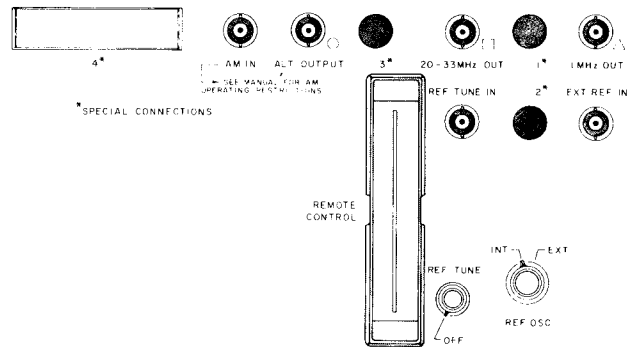
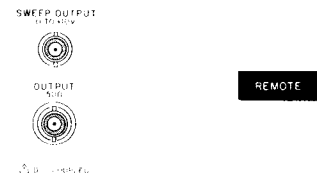
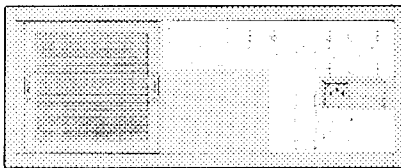
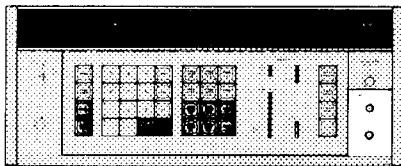

SWEEP OUTPUT
Provides a stepped dc output from 0 Vdc to 10 Vdc. Number of steps and time for each step are controlled by the SWEEP STEPS control and the SWEEP TIME/STEP control respectively. Each step represents the same step in the frequency or amplitude sweep.

OUTPUT
3330A/B front panel output.

BCD OUTPUT
Special BCD output. The BCD frequency and amplitude information from the

3330A/B Controller which sets the 3330A/B frequency and amplitude is available at this connector. There are 33 lines of frequency information and 16 lines of amplitude information plus 1 ground line. (See Section IV for information concerning BCD signals). This output available by request only.

AM IN
Amplitude Modulation Input. An external signal can be applied to this connector to amplitude modulate the 3330A/B signal.

3330A: A dc to 100 kHz signal may be used to amplitude modulate the 3330A signal. Percent of modulation is proportional to the AM IN voltage (0.95 V rms for 95% modulation, 0.01 V rms for 1% modulation). The 3330A front panel amplitude control can be varied to adjust the level of the carrier signal without changing the modulation percentage.

3330B: When an amplitude modulating signal is applied, the output power level is a combination of the carrier power and sideband power. The 3330B output is monitored by a thermal detector circuit, which is a constant power device. Therefore, when the amplitude modulating signal is applied, the carrier level is decreased to maintain a constant power level. Conversely, if the 3330B front panel amplitude control settings are changed to increase or decrease the carrier level, the sideband levels are decreased or increased accordingly. It is recommended that an oscilloscope be used at the 3330B output to observe the modulated signal and determine the percent of modulation. Because the characteristics of each instrument are slightly different, the curves shown in Figure 3-1 are an approximation of the AM voltage input needed in a standard instrument for the percent of modulation desired. The dB figure of each solid line curve represents the dB level below the highest output of each 10 dB step of the output attenuator. For example, the - 4 dB curve would apply for a front panel amplitude setting of +9.44 dB, - 0.56 dB, - 10.56 dB, etc.

NOTE

If the level of the modulated output signal exceeds 2.97 V peak-to-peak as observed on an oscilloscope (1.05 V rms), the signal will be degraded because of excessive limiting in the instrument. (14.14 V peak-to-peak, 5 V rms, for Option 005.)

The broken-line curve of Figure 3-1 can be used to determine the carrier level out of the 3330B for a given percent of modulation. The vertical axis labeled K represents the dB loss in carrier level due to the modulating voltage. Subtract this reading from the 3330B front panel amplitude setting to find the output carrier level.



3330A/B rear panel triaxial output jack. Requires internal cable change from front panel output jack.



Holes for special purpose jacks. (See Paragraph 3-24).



Output from Frequency Generating section of 3330A/B. Tracks front panel output with a 20 MHz offset. Output voltage = > 100 mV rms/50 ohms.



1 MHz output from 20 MHz VCXO Reference. Output Voltage = > 220 mV rms/50 ohms.

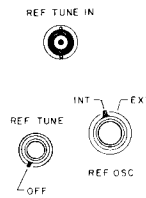

Reference input for tuning Reference Oscillator and Internal Reference Oscillator Adjust. With rear panel REF TUNE control in INT position (position 3330A/B), 5 Vdc changes frequency a maximum of 0.5 to 1×10^{-7} of frequency at 0 Vdc. - 5 Vdc changes frequency a maximum of - 0.7 to $- 1.5 \times 10^{-7}$ of frequency at 0 Vdc. With rear panel REF OSC in EXT position (standard 3330A/B) and no external reference applied, ± 5 Vdc changes frequency a nominal 4×10^{-5} of frequency at 0 Vdc. With REF OSC in INT position, the REF TUNE IN is applied to the 5 MHz VCXO. With REF OSC in EXT position, the REF TUNE IN is applied to the 20 MHz VCXO. If the REF OSC is in the EXT position and an external reference is used, the external reference signal overrides the REF TUNE IN. With the 3330A/B Option 003, the REF TUNE IN has a nominal 4×10^{-5} change of frequency at 0 Vdc if the REF OSC is in the INT position or EXT position with no external reference applied. With an external reference applied and the REF OSC in the EXT position, the external reference overrides the REF TUNE IN. In the 3330A/B Option 003, the REF TUNE IN is applied to the 20 MHz VCXO. The REF TUNE potentiometer on the rear panel of the 3330A/B has the same characteristics as the REF TUNE IN. The REF TUNE IN, however, will override the REF TUNE potentiometer if both are used.



Input for an external frequency reference. The 3330A/B 20 MHz VCXO is phase-locked to the external oscillator. Any sub-harmonic of 20 MHz from 1 MHz through 10 MHz, at 200 mV to 2 V, may be used.

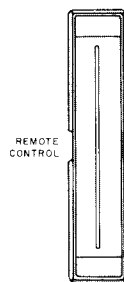

Remote Control input/output. The 3330A/B can be remotely controlled using a seven bit ASCII character format within the HP-IB (see Paragraph 3-19). Twelve lines are required for remote control. Also available at this connector are 15 lines of sweep information. A step count (0-1000) on 12, 1-2-4-8, BCD lines indicates the sweep position (count of 500 indicates center frequency). A sweep status line indicates when instrument is sweeping. A step ready line indicates the instrument has spent the prescribed time on one step and is ready to go to the next step. A step inhibit line is also available. When this line is grounded, the instrument will stop sweeping on that step. Figure 3-2 shows the input/output connector pin numbers and signal inputs/outputs for remote input and sweep output.

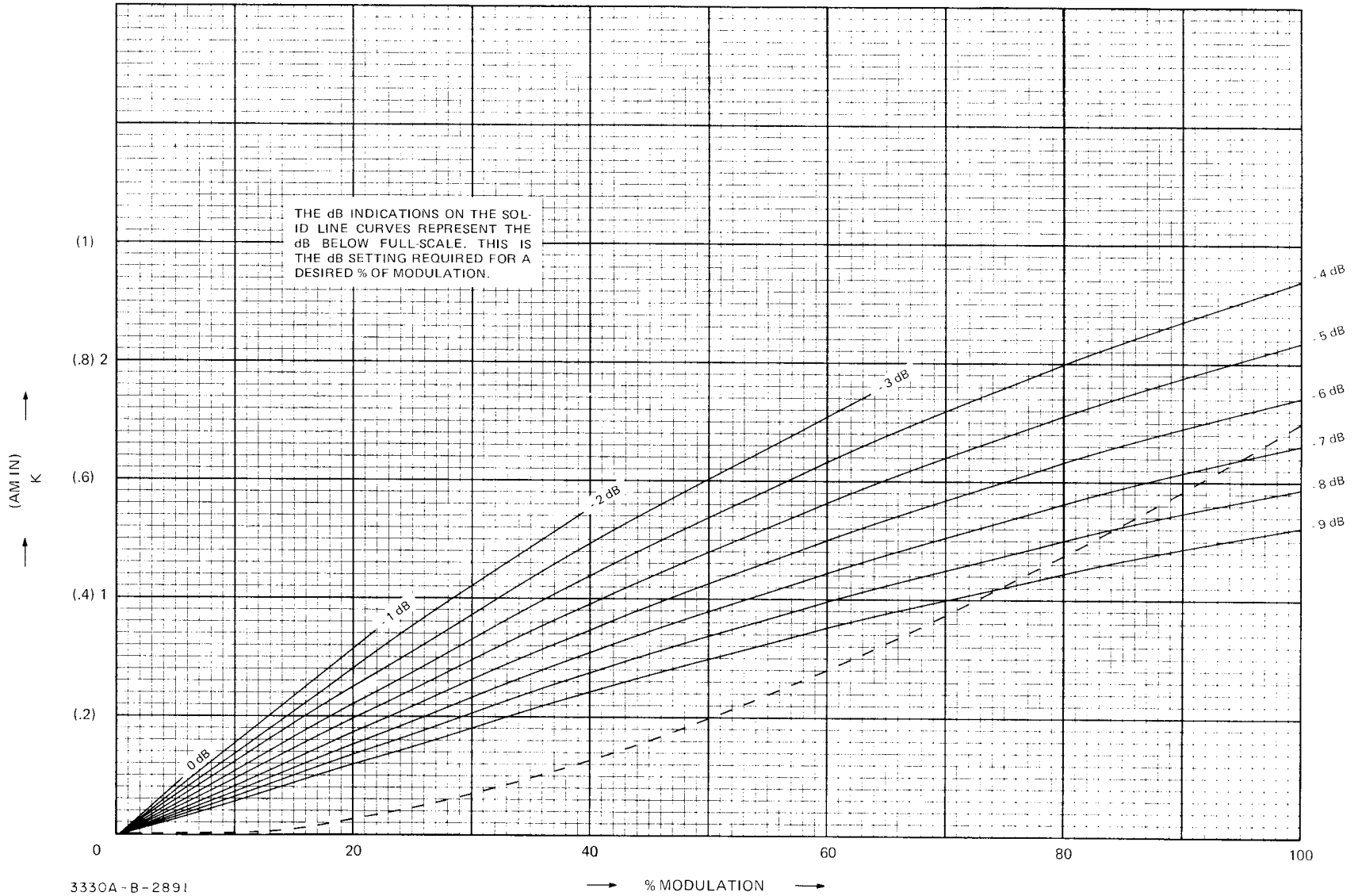

3330A-B-2891

Figure 3-1. AM IN.



Indicates instrument is in remote programming mode.

3-19. Remote Hewlett-Packard Interface Bus (HP-IB) Programming.

3-20. The 3330A/B can be remotely programmed using a seven bit ASCII character format. An octal code is used to identify each HP-IB programming instruction. Table 3-1 lists the instructions for the 3330A/B and their equivalent octal codes. In order to exercise maximum capability, 12 input lines are required. Figure 3-2 shows the HP-IB remote input connector pin numbers and the signal inputs for each pin. All front panel functions on both the 3330A and 3330B are programmable with the exception of the POWER LINE and 3330A AMPLITUDE.

3-21. A major advantage of HP-IB programming is the capability of paralleling several 3330A/B Automatic Synthesizers, or complimentary HP-IB programmable instruments, to the same input lines. Each instrument can be given an individual address which only that instrument

recognizes. All 3330A/B Automatic Synthesizers leave the factory with an address of 44, but this address can easily be changed. To accomplish this, a series of jumpers on the Input Assembly (A6) of the controller section must be set in a binary fashion which corresponds to the octal code for the address desired. Table 3-2 gives the binary number and the corresponding octal code and ASCII character for the different addresses available. The 40 bit of the address is hard wired in the instrument. Only the 20-10-4-2-1 bits can be changed. Figure 3-3 shows the five jumpers for changing the address.

3-22. When the 3330A/B is initially turned on in the remote mode, the conditions programmed are the same as the conditions programmed at turn-on when operating from the front panel (see Paragraph 3-6).

3-23. To program the 3330A/B, the address preface ATN (Attention) is given followed by the address of the instrument to be programmed. Once the instrument has been addressed, it can be programmed by issuing the proper commands in the same manner as the instrument is

Table 3-1. 3330A/B HP-IB Programming Codes.

Key/Switch Position	ASCII Character	Octal Code	Key/Switch Position	ASCII Character	Octal Code
(Address) *	\$	044	Ampl (A)	N	116
			Ampl Step	O	117
Freq (F)	L	114	+ dBm	;	073
Freq Step	M	115	- dBm	<	074
0	0	060	Leveling Off	←	137
1	1	061	Leveling Slow]]	135
2	2	062	Leveling Fast	↑	136
3	3	063			
4	4	064	Ampl Step X10	'	042
5	5	065	Ampl Step ÷ 10	#	043
6	6	066	Ampl Step X 2	&	046
7	7	067	Ampl Step ÷ 2	'	047
8	8	070	Ampl ↑)	051
9	9	071	Ampl ↓	(050
.	.	072	Ampl Sweep Mode	C	103
Hz	=	075	1 ms/Step	P	120
kHz	>	076	3 ms/Step	Q	121
MHz	?	077	10 ms/Step	R	122
			30 ms/Step	S	123
Freq Step X10	Space	040	100 ms/Step	T	124
Freq Step ÷ 10	!	041	300 ms/Step	U	125
Freq Step X2	\$	044	1000 ms/Step	V	126
Freq Step ÷ 2	%	045	3000 ms/Step	W	127
Freq ↑	*	052	Stop	X	130
Freq ↓	+	053	Start Cont	Y	131
Freq Sweep Mode	B	102	Start Single	[133
			First Point	Z	132
Sweep Up	I	111	Clear*	?	077
Sweep Down	J	110			
Sweep Both	K	113			
10 Steps/SWP	D	104			
100 Steps/SWP	E	105			
1000 Steps/SWP	G	107			

Address and clear must be accompanied by an ATN. On 3260A Card Reader ATN = 200 (address = 244, Clear = 277).

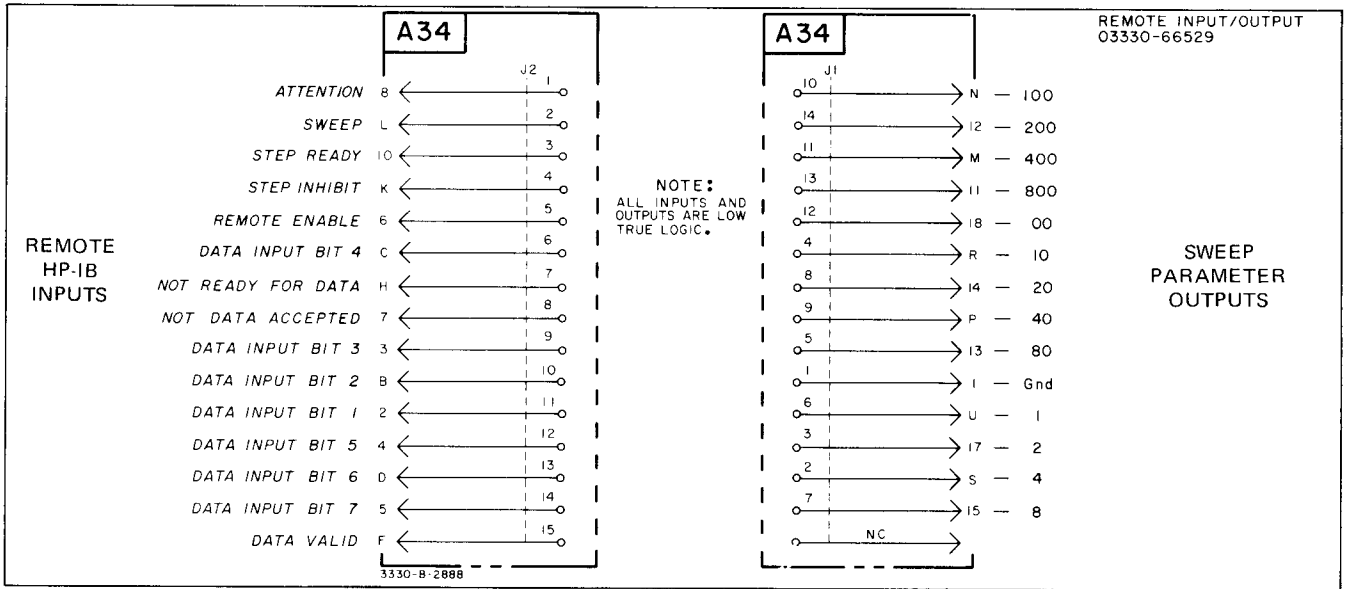

Figure 3-2. HP-IB Remote Input.

programmed from the front panel. If more than one instrument is paralleled on the same HP-IB, it is necessary to “clear” the line before addressing another instrument. The code for clearing the HP-IB is given in Table 3-1. A timing diagram for the output control lines is shown in Figure 3-4. A brief explanation of the timing functions is included with the figure.

3-24. Special Connectors.

3-25. The 3330A/B has been designed with several special interfacing possibilities available. These special connections allow interfacing with complementary equipment to increase the flexibility of the 3330A/B. The connections include an output from the 20 MHz VCXO, an output from N4 loop VTO, an input to the SL3 loop Phase Detector, and an input to the Mixer in the Output Section.

3-26. The special 20 MHz output, when connected, will

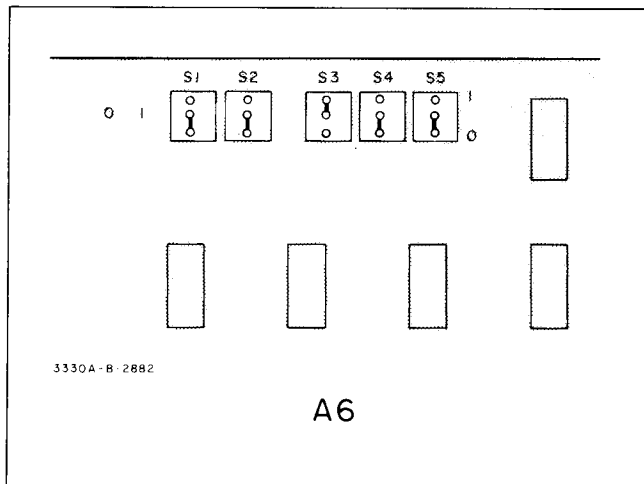

Figure 3-3. Addressing Jumpers.

Table 3-2. Addressing Codes.

Bus Address	40	20 SW1	10 SW2	4 SW3	2 SW4	1 SW5
40	1	0	0	0	0	0
701	1	0	0	0	0	1
702	1	0	0	0	1	0
703	1	0	0	0	1	1
704	1	0	0	1	0	0
705	1	0	0	1	0	1
706	1	0	0	1	1	0
707	1	0	0	1	1	1
708	1	0	1	0	0	0
709	1	0	1	0	0	1
710	1	0	1	0	1	0
711	1	0	1	0	1	1
712	1	0	1	1	0	0
713	1	0	1	1	0	1
714	1	0	1	1	1	0
715	1	0	1	1	1	1
716	1	1	0	0	0	0
717	1	1	0	0	0	1
718	1	1	0	0	1	0
719	1	1	0	0	1	1
720	1	1	0	1	0	0
721	1	1	0	1	0	1
722	1	1	0	1	1	0
723	1	1	0	1	1	1
724	1	1	1	0	0	0
725	1	1	1	0	0	1
726	1	1	1	0	1	0
727	1	1	1	0	1	1
728	1	1	1	1	0	0
729	1	1	1	1	0	1
730	1	1	1	1	1	0

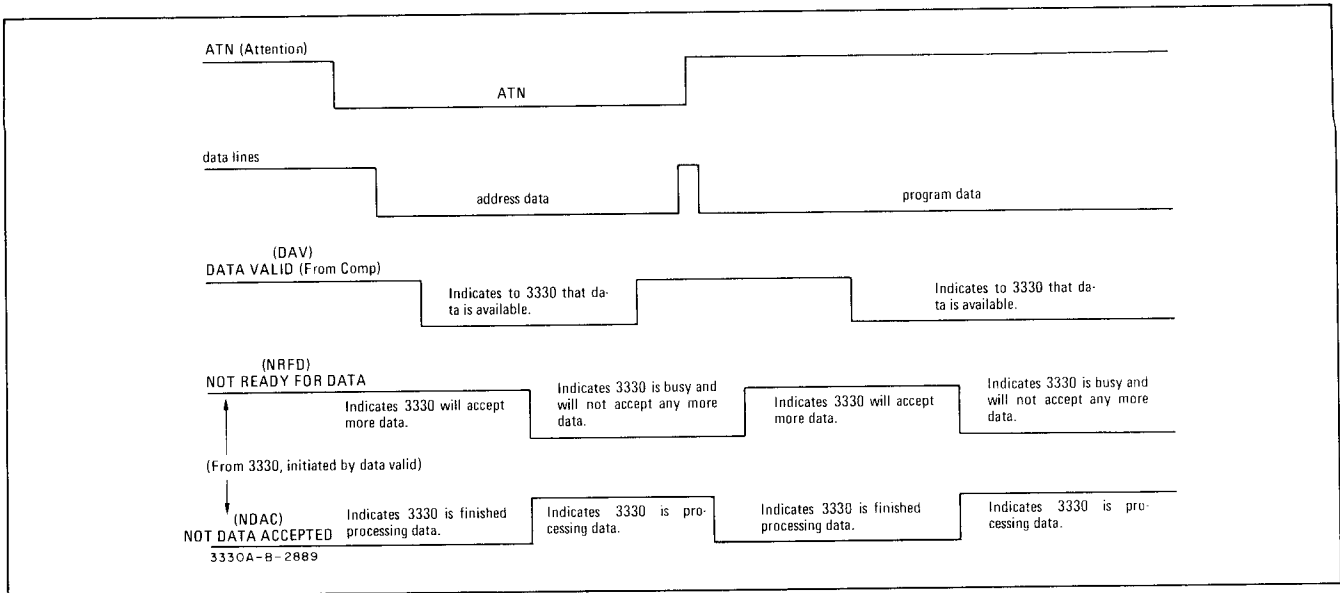

Figure 3-4. HP-IB Timing Diagram.

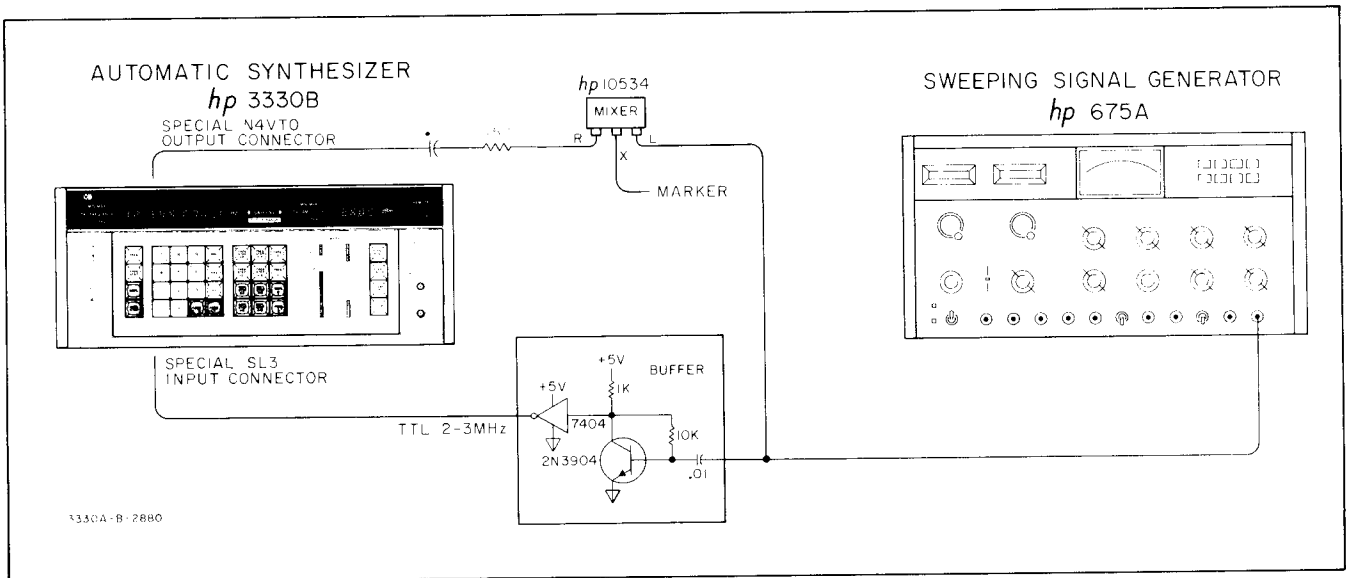

Figure 3-5. Special N4 Loop and SL3 Loop Connectors.

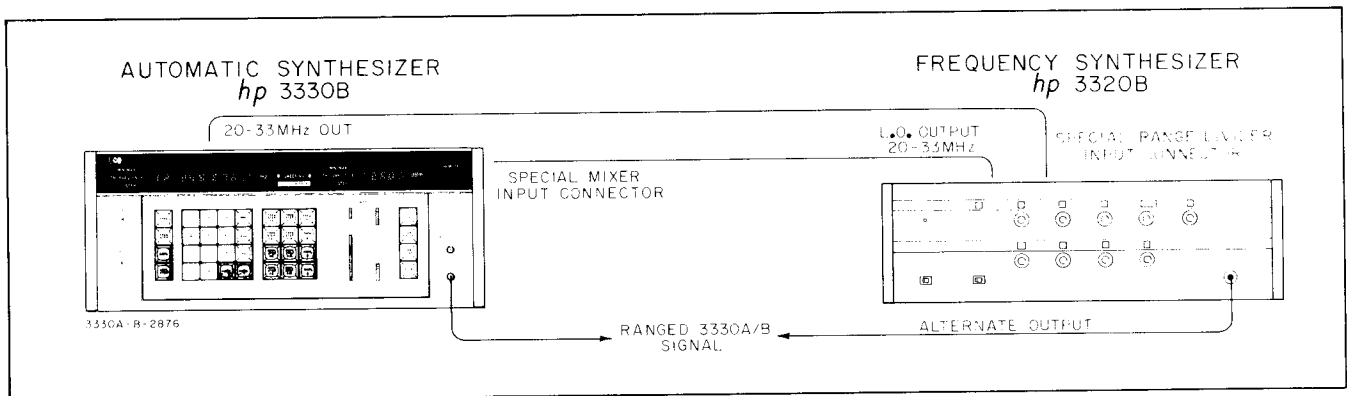

Figure 3-6. Special Mixer Input Connector.

supply the 20 MHz reference frequency to the rear panel. This signal has the same accuracy and stability as the 5 MHz reference oscillator but a significant level of spurious and harmonic content is present.

3-27. The special N4 loop VTO output will supply the N4 loop VTO signal divided by 10 to the rear panel. This output is designed to be used in conjunction with the special SL3 loop Phase Detector input. The SL3 loop input allows the operator to apply an external TTL logic signal of 2-3 MHz to increase the resolution of the 3330A/B output. The resolution of the 3330A/B output will be determined by the resolution of the external 2-3 MHz. The output from the N4 loop VTO can be externally mixed with the external 2-3 MHz signal to provide marker pulses (see Figure 3-5).

3-28. The special Mixer input is designed to be used in conjunction with the 20-33 MHz OUT on the 3330A/B rear panel. The 20-33 MHz OUT is applied to a special 3320A/B where it is divided by factors of 10 in the 3320A/B range dividers (see Figure 3-6). The 20-33 MHz OUTPUT on the rear panel of the 3320A/B is applied to the 3330A/B special Mixer input. The resulting output of the 3330A/B is a stable frequency which can be ranged by factors of 10. The full capability of the 3330B amplitude range and sweep can be used.

3-29. For more information concerning these special connections, contact your local -hp- Sales and Service Office.

3-30. SWITCHING TRANSIENTS.

3-31. Frequency Switching.

3-32. The transients encountered in the 3330A/B output as

a result of frequency switching (frequency step or sweep, for example) are related to the frequency changes in the ÷ N and Summation Loop circuits. The severity and duration of the transients are a function of the magnitude and significance of the digits being switched. The simplified block diagram in Figure 3-7 shows how the frequency digits are added in each loop to obtain the final output frequency. From this it can be seen that the transients of phase-lock loop 1 and summation loop 1 translate directly to the output, while transients resulting in the other loops are reduced in proportion to the frequency division. Figure 3-8 shows three examples of frequency switching transients.

3-33. Amplitude Switching.

3-34. The nature of transients introduced by amplitude switching depends on whether or not the step attenuator is involved. For example, when stepping from + 3.44 to + 3.45 dBm during an amplitude sweep, the step attenuator goes from 10 to 0 dB while the leveling loop electronic attenuator goes from 0.00 to 9.99 dB. The resulting behavior is shown in Figure 3-10.

3-35. An open-loop reset signal enables the electronic attenuator to switch to about 20% of final value within a few milliseconds. The remaining part of the transient is governed by the closed-loop time constant and is about 35 ms with the front panel LEVELING switch set for FAST, or about 350 ms in SLOW. (The slow response is provided to permit leveling at output frequencies as low as 10 Hz.)

3-36. When the 3330B is turned on with the LEVELING control in the OFF or FAST position and subsequently changed to SLOW, there will be no output for a period of about six seconds after changing to SLOW. It is therefore recommended that when remotely programming the first

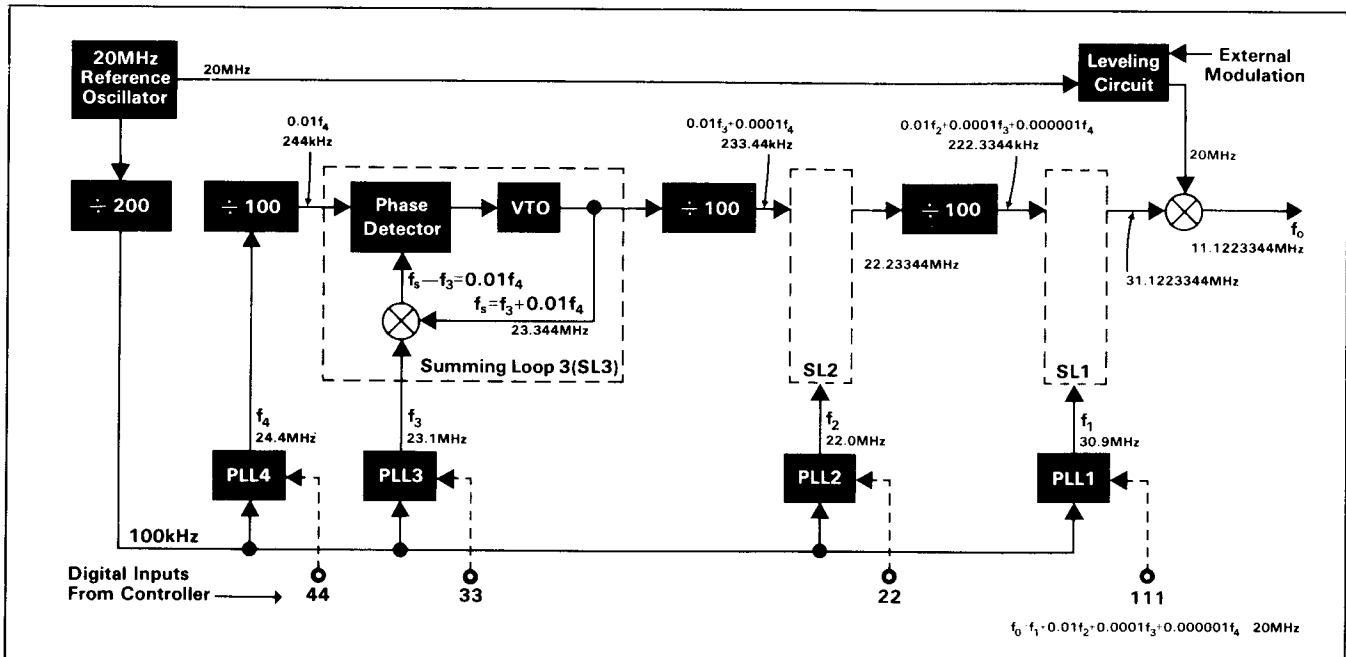

Figure 3-7. Simplified Block Diagram of Frequency Generating Circuits.

change to SLOW after turn on, a wait of at least six seconds be included in the program. This situation does not exist if the control is in the SLOW position when the instrument is

first turned on, nor does it occur after the first change to SLOW. Also, output is continuous if the instrument is turned on in OFF or FAST and is not changed to SLOW.

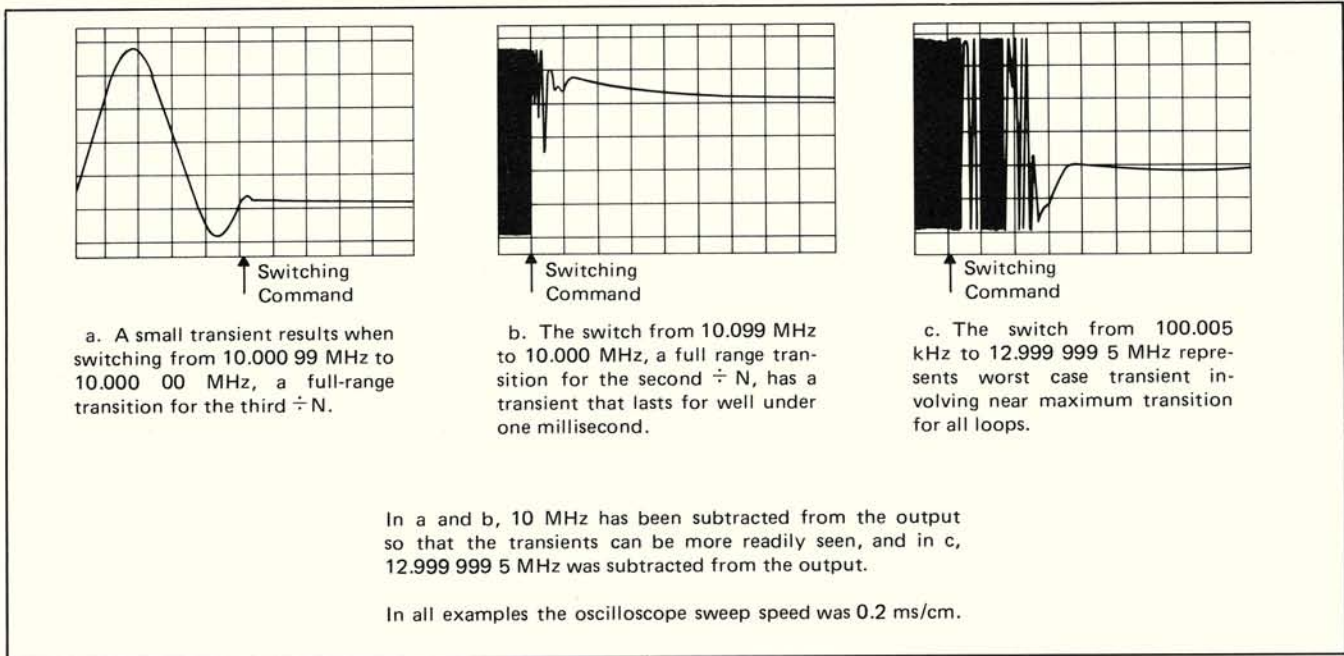

Figure 3-8. Frequency Switching Transients.

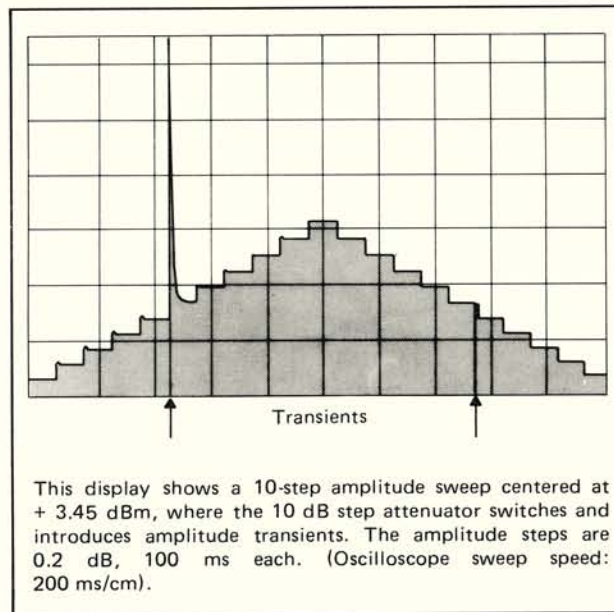

Figure 3-9. Amplitude Switching Transients.

SECTION IV THEORY OF OPERATION

4-1. INTRODUCTION.

4-2. This section contains a block diagram description of the Model 3330A/B Automatic Synthesizer. The description will be broken into two parts, general and basic block. For all descriptive purposes, refer to the Block Diagram, Figure 7-5, and schematics, Figures 7-6 through 7-27.

4-3. GENERAL DESCRIPTION.

4-4. The 3330A/B develops the output signal by an indirect synthesis technique. This technique uses tunable oscillators, phase-locked to harmonics of a reference oscillator (see Figure 4-1). The signal from the phase-locked oscillators is applied to the Output Section which is also referenced to the reference oscillator. The resulting output of the Output Section is a precise, stable signal in both frequency and amplitude. Both the frequency of the phase-locked loops and the amplitude of the Output Section are selected by a controller. The controller, in turn, is operated by the front panel keyboard or the remote input.

4-5. BASIC BLOCK DESCRIPTION.

4-6. For description purposes, the 3330A/B Block description will be broken into four sections: Reference Oscillator, Frequency Generation, Output and Controller.

4-7. Reference Oscillator.

4-8. The reference oscillator for the 3330A/B is a 20 MHz Voltage Controlled Crystal Oscillator (VCXO) phase-locked to a 5 MHz, oven stabilized, VCXO (see Figure 4-2). Phase locking is accomplished by applying the output of the 20 MHz VCXO and the output of the 5 MHz VCXO to a phase detector in the Reference Frequency Sampler Assembly. Any difference in phase creates a dc level at the phase detector output. This dc level is applied to the varicap in the 20 MHz VCXO correcting its output frequency.

4-9. There are four different frequencies out of the reference oscillator section. Twenty MHz is applied directly to the Output Modulator. Twenty MHz is divided to 100 kHz in the 20 MHz VCXO and applied to the $\div N$ loops in the frequency generation section. Twenty MHz is divided to 2 MHz and 1 MHz in the Reference Frequency Sampler. The 1 MHz signal is applied to a rear panel output jack and the 2 MHz is applied to the Output Amplitude Reference Assembly.

4-10. Increased stability can be gained in the 3330A/B by using an external frequency reference to replace the 5 MHz VCXO. Any subharmonic of 20 MHz from 1 MHz through 10 MHz with an amplitude of 200 mV rms to 2 V rms and an accuracy of $\pm 10^{-5}$ can be used. The 20 MHz reference oscillator is phase-locked to this signal. A 3330A/B rear panel switch is used to select internal or external references.

4-11. Frequency Generation.

4-12. The frequency generation section of the 3330A/B is composed of four phase-locked divide ($\div N$) loops and three phase-locked summation (SL) loops (see Figure 4-3). The output frequency is variable from 20,000,000.0 Hz to 33,000,999.9 Hz. The digits of the output frequency are controlled by the $\div N$ loops and effectively summed in the

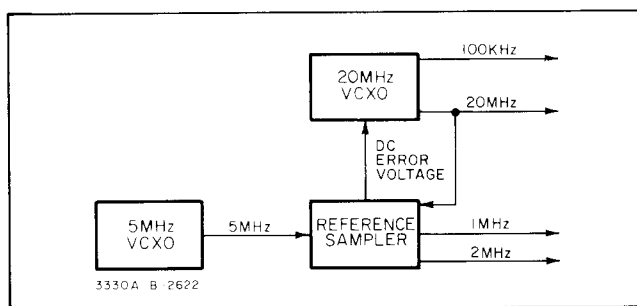

Figure 4-2. Reference Oscillator.

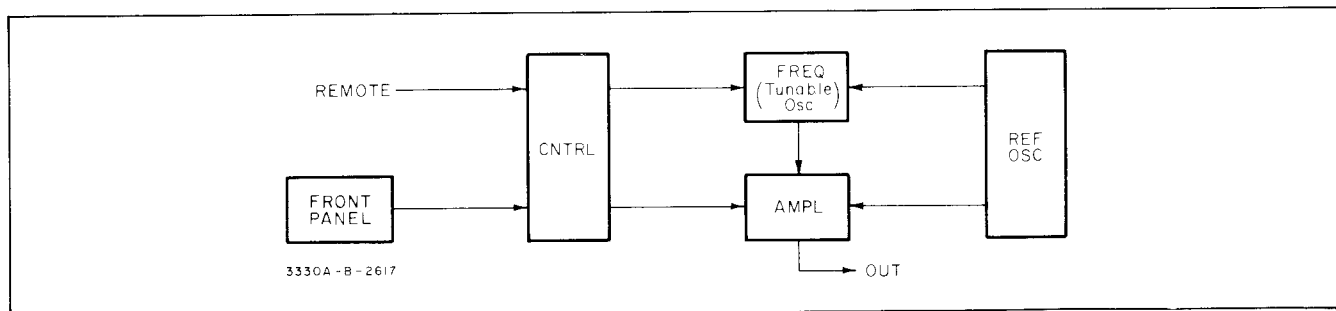

Figure 4-1. Simplified Block Diagram.

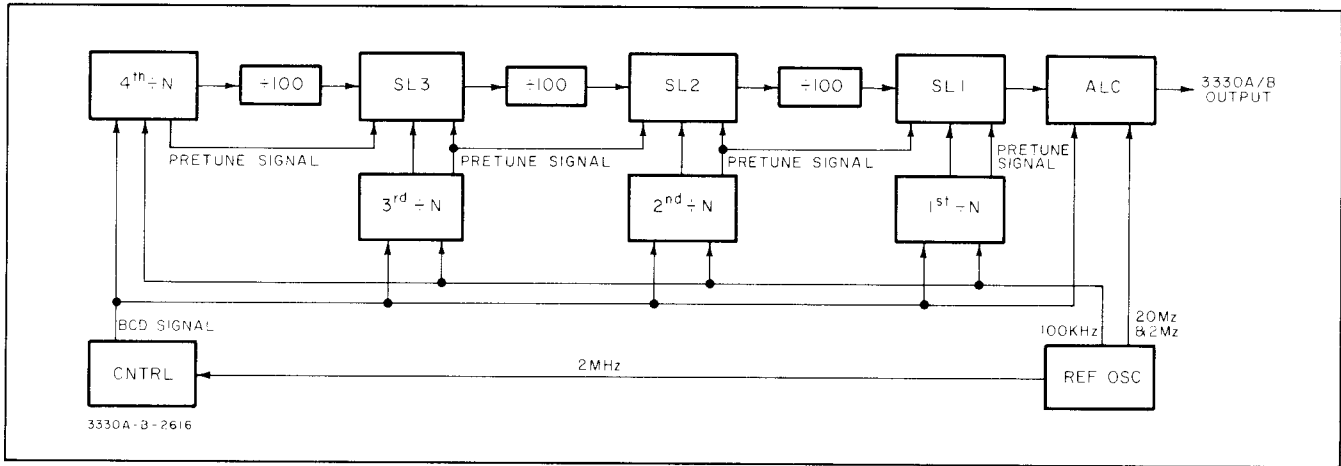

Figure 4-3. Basic Block Diagram.

summation loops. The first, second and third digits are controlled by the 1st ÷ N loop, the fourth and fifth digits are controlled by the 2nd ÷ N loop, the sixth and seventh digits are controlled by the 3rd ÷ N loop, and the eighth and ninth digits are controlled by the 4th ÷ N loop.

20,000,000.0

4th ÷ N loop
 3rd ÷ N loop
 2nd ÷ N loop
 1st ÷ N loop

The frequency out of the ÷ N loop is selected by an 8-4-2-1 BCD signal from the controller section (see Paragraph 4-26). The frequency ranges of the ÷ N loops are:

4th ÷ N	20.0 MHz to 29.9 MHz
2nd and 3rd ÷ N	19.8 MHz to 29.7 MHz
1st ÷ N	19.8 MHz to 32.8 MHz

The actual frequency out of each ÷ N loop for a specific setting of the front panel keyboard can be determined by adding the digits controlled by that ÷ N loop to the lowest frequency out of the loop.

Example:

12.3456789 MHz	keyboard selection
20.0 MHz	lowest frequency 4th ÷ N
<u>8 9</u>	digits controlled by 4th ÷ N
28.9 MHz	output of 4th ÷ N
19.8 MHz	lowest frequency 3rd ÷ N
<u>6 7</u>	digits controlled by 3rd ÷ N
26.5 MHz	output of 3rd ÷ N
19.8 MHz	lowest frequency 2nd ÷ N
<u>4 5</u>	digits controlled by 2nd ÷ N
24.3 MHz	output 2nd ÷ N

19.8 MHz

12 3

32.1 MHz

lowest frequency 1st ÷ N
 digits controlled by 1st ÷ N
 output 1st ÷ N

The output frequency of the SL3 loop is equivalent to the output of the 4th ÷ N loop divided by 100 plus the output of the 3rd ÷ N loop.

Example:

28.9	MHz output 4th ÷ N
<u>.289</u>	MHz 4th ÷ N ÷ 100
26.500	MHz output 3rd ÷ N
26.789	MHz output SL3 loop

The output frequency of the SL2 loop is equivalent to the output of the SL3 loop divided by 100 plus the output of the 2nd ÷ N loop:

Example:

26.789	MHz output SL3 loop
<u>.26789</u>	MHz SL3 loop ÷ 100
24.3	MHz output 2nd ÷ N
24.56789	MHz output SL2 loop

The output frequency of the SL1 loop is equivalent to the output of the SL2 loop divided by 100 plus the output of the 1st ÷ N loop:

Example:

24.56789	MHz output SL2 loop
<u>.2456789</u>	MHz SL2 loop - 100
32.1	MHz output 1st ÷ N
32.3456789	MHz output SL1 loop

The output frequency of the SL1 loop is mixed with

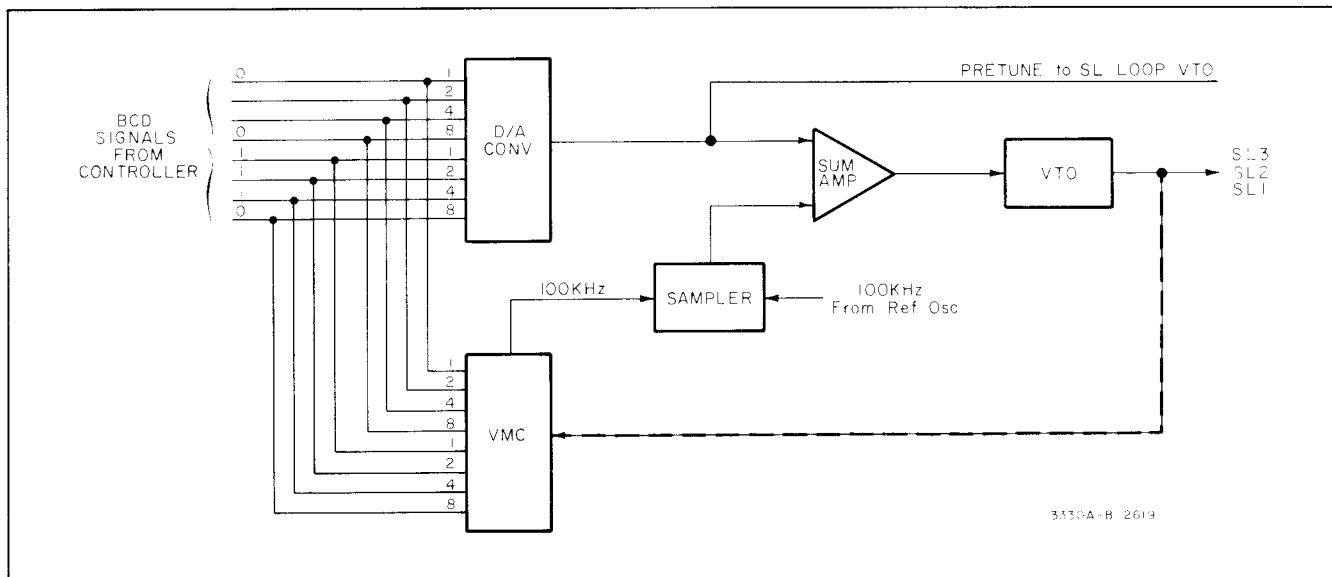

Figure 4-4. ÷ Loop.

20 MHz in the Output Section and the difference frequency is present at the 3330A/B output jack:

Example:

32.3456789 MHz	output SL1 loop
20.0000000 MHz	Output Section
12.3456789 MHz	3330A/B output (represents keyboard selection)

4-13. ÷ N Loop. Each of the four phase locked ÷ N loops consist basically of a Digital to Analog Converter (D/A), a Voltage Tuned Oscillator (VTO), a Variable Modulus Counter (VMC), and a Sampler (see Figure 4-4). Two 8-4-2-1 BCD signals from the controller are applied to the D/A and the VMC. These signals represent the keyboard selection of the digits controlled by the ÷ N loop in question. For example, suppose the ÷ N loop in Figure 4-4 is the 3rd ÷ N loop. The digits controlled by this loop are the sixth and seventh digits. If the keyboard selection is 12.3456789 MHz, then 6 and 7 are the digits represented by the BCD signal. The BCD code is 0-1-1-0 for 6 and 0-1-1-1 for 7. In the D/A Converter, the BCD signal is converted to an analog voltage and applied to the VTO to set its oscillating frequency. In the VMC, the BCD signal sets the divide number of the counter.

4-14. For fine tuning of the VTO, the VMC divides the VTO output by the number N set by the BCD signal. If the VTO is oscillating at the proper frequency, the VMC output will be 100 kHz. For example, with the keyboard selection of 12.3456789 MHz the VTO frequency should be 26.5 MHz. If the VTO is oscillating at exactly 26.5 MHz, the VMC output will be 100 kHz. If the VTO is oscillating at 26.5 MHz ± some error, the VMC output will be 100 kHz ± a proportional error. The VMC output is applied to the Sampler where it is compared to 100 kHz from the Reference Oscillator. Any phase difference between the two signals is detected and a dc voltage

proportional to this difference is applied to the VTO as a correction voltage.

4-15. In the 4th ÷ N loop, only six of the eight BCD signal lines connect to the D/A. The two least significant bits of the first frequency digit are applied to the VMC only. In the 1st ÷ N loop, there are nine BCD lines. The ninth line represents the overrange digit when a frequency above 9.9999999 MHz is selected on the keyboard.

4-16. SL Loop. Each of the three SL loops consists basically of a divide-by-100 circuit (÷100), a Phase Monitor, a Phase Detector, a Summing Amplifier, a VTO and a Mixer (see Figure 4-5). There are two pretune signals for each SL loop VTO. These signals are the analog signals from the ÷ N loop D/A that sets the ÷ N loop VTO (see Figures 4-3 and 4-4). The two pretune signals for the SL3 loop are from 4th ÷ N loop D/A and the 3rd ÷ N loop D/A. The two pretune signals for the SL2 loop are from the 3rd ÷ N loop and the 2nd ÷ N loop. The two pretune signals for the SL1 loop are from the 2nd ÷ N loop and the 1st ÷ N loop. These pretune signals set the SL loop VTOs within approximately 100 kHz of the desired frequency.

4-17. Fine Tuning of the SL loop is accomplished with the signal applied to the ÷100 and the signal applied to the Mixer (see Figure 4-5). The signal applied to the ÷100 comes from the 4th ÷ N loop, the SL3 loop, or the SL2 loop depending on whether Figure 4-5 represents the SL3 loop, the SL2 loop, or the SL1 loop respectively. The frequency of this signal is 20.0 MHz to 30.0 MHz. The ÷ 100 divides the signal to a range of 200 kHz to 300 kHz and applies it to the Phase Monitor. The signal applied to the Mixer comes from the 3rd ÷ N loop, the 2nd ÷ N loop, or the 1st ÷ N loop again depending on whether Figure 4-5 represents the SL3 loop, the SL2 loop, or the SL1 loop respectively. The frequency of this signal is 19.8 MHz to 29.7 MHz for the 2nd or 3rd ÷ N loop sources or 19.8 MHz to 32.8 MHz for the 1st ÷ N loop source. It is mixed with

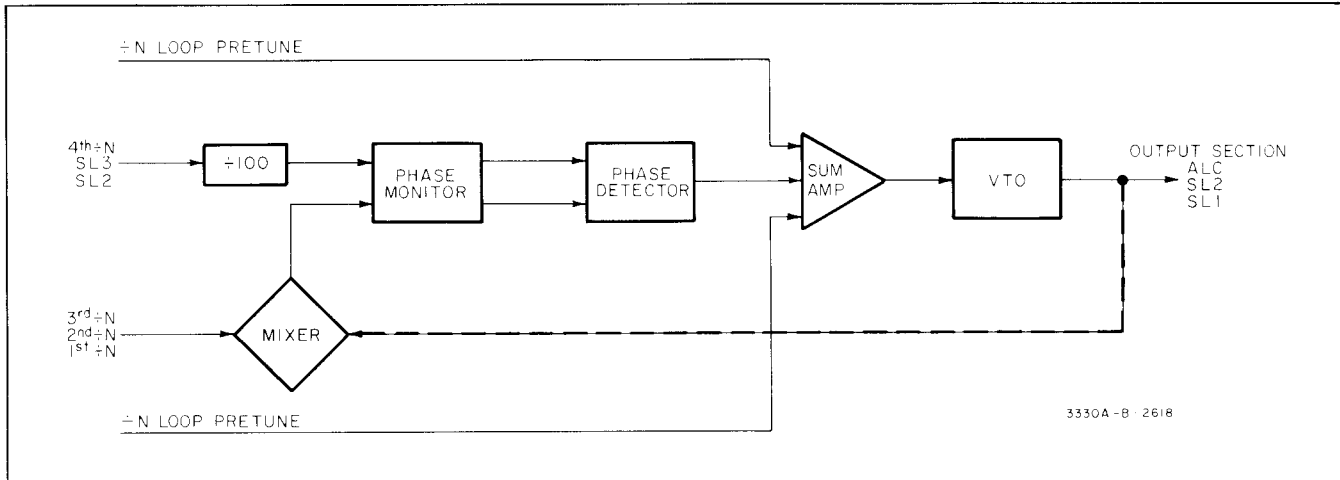

Figure 4-5. SL Loop.

the output of the SL loop VTO whose frequency is 20.0 MHz to 30.0 MHz for the SL2 or SL3 loops or 20.0 MHz to 33.0 MHz for the SL1 loop. The difference frequency of 200 kHz to 300 kHz out of the Mixer is applied to the Phase Monitor.

Example:

12.3456789 MHz keyboard

Figure 4-5	=	SL3 loop
input to ÷ 100	=	28.9 MHz
÷ 100 output	=	289 kHz
input to Mixer	=	26.5 MHz
from 3rd ÷ N loop	=	26.789 MHz ± error
pretuned VTO	=	289 kHz ± error
output of Mixer	=	correction voltage to VTO
from Phase Det.	=	± error

4-18. The signal from the ÷ 100 and the signal from the Mixer are applied to the Phase Detector from the Phase Monitor. If the two signals trigger the Phase Detector at the same time, erroneous outputs will occur from the Phase Detector. The Phase Monitor converts the two signals to

200 ns pulses and monitors them. If the pulses occur simultaneously, the Phase Monitor will blank them.

4-19. The two signals from the Phase Monitor are compared in the Phase Detector. Any phase difference between the two signals is detected and a dc voltage proportional to this difference is applied to the VTO, through the Summing Amplifier, as a correction voltage.

4-20. Output Section.

4-21. The 3330A amplitude is controlled by adjusting the amplitude of the 20 MHz from the Reference Oscillator (see Figure 4-6). This is accomplished by modulating the 20 MHz with a dc level. The dc level is selected by a 0-13 dBm front panel potentiometer. The dc modulated 20 MHz is then applied to a Mixer where it is mixed with the output signal of the frequency generating section. The difference frequency out of the Mixer is filtered, amplified and applied to the 3330A output jack.

4-22. The 3330B amplitude is controlled in the same manner as the 3330A amplitude with two exceptions. There is a BCD controlled 10 dB attenuator on the output of the amplifier, and the modulating dc is derived from a

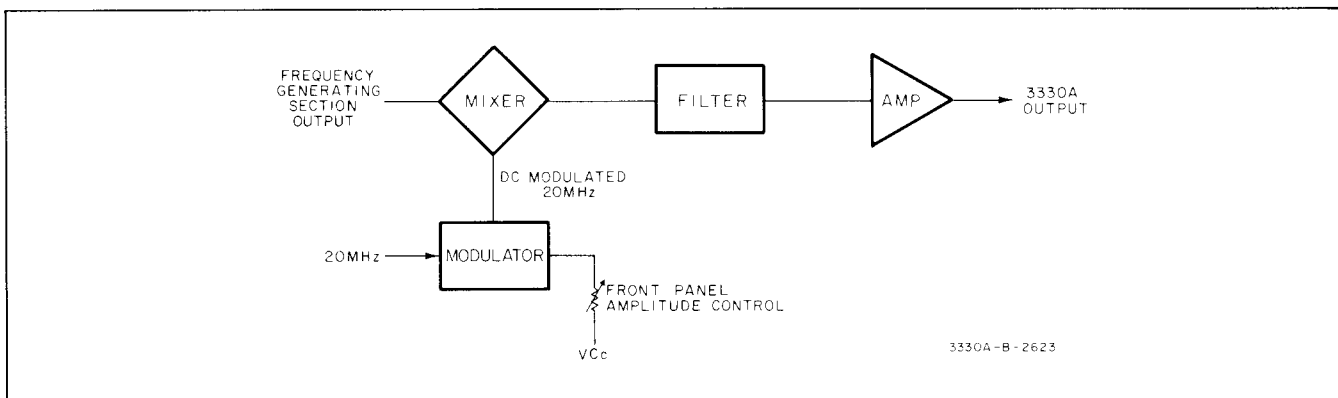

Figure 4-6. 3330A Amplitude.

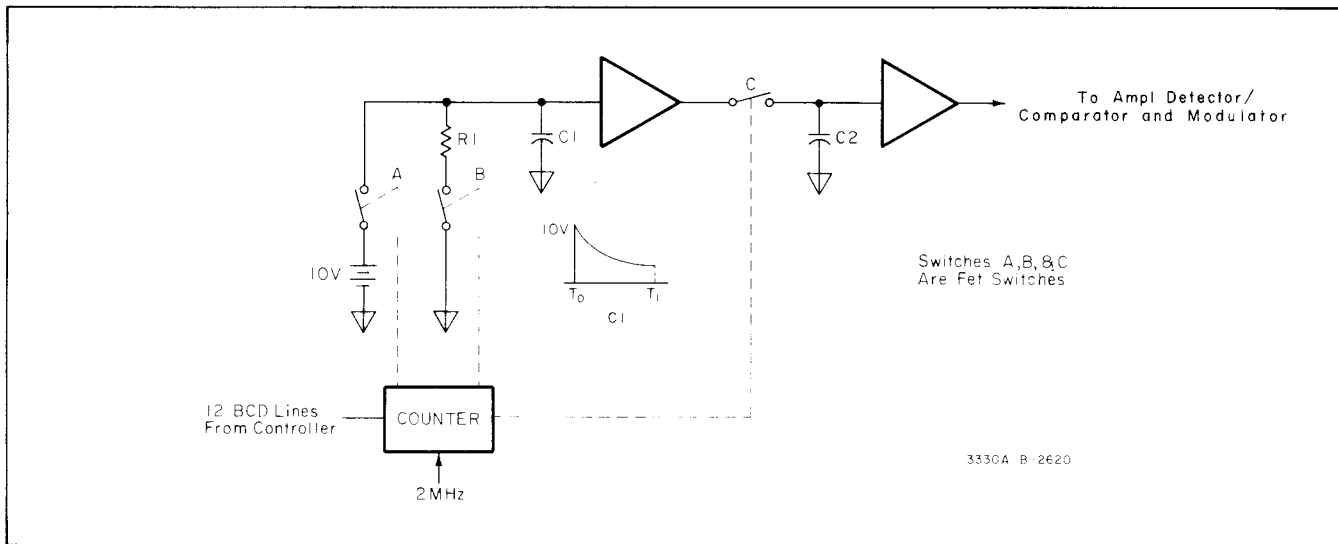

Figure 4-7. Simplified Amplitude Reference.

BCD controlled Amplitude Reference and a Detector Comparator.

4-23. The 3330B amplitude is adjustable from +13.44 dBm to -86.55 dBm. Each of the four digits of amplitude are represented by an 8-4-2-1 BCD signal from the controller. The BCD signal is not a direct representation of the keyboard selection. The keyboard selection is acted upon by a constant (13.44) and the resulting digits are represented by the BCD signal. This signal can be derived by the following formula:

13.44 - keyboard selection = digits represented by BCD signal = attenuation, in dB, from full 3330B output.

Example:

1: keyboard selection = + 10.00 dBm
 13.44 - 10.00 = 03.44 dBm = digits represented by BCD signal =
 0000 0011 0100 0100

2: keyboard selection = - 55.55 dBm
 13.44 - (- 55.55) = 68.99 dBm = digit represented by BCD signal =
 0110 1000 1001 1001

The BCD signal from the controller for the most significant amplitude digit is applied to the 10 dB Attenuator. The BCD signals for the three least significant digits are applied to the Amplitude Reference.

4-24. The Amplitude Reference consists of a counter, clocked with a 2 MHz signal from the Reference Oscillator, and a series of FET switches controlling the charge and discharge of a capacitor (see Figure 4-7). The BCD signal determines the length of time the counter counts. At T_0 , switch A is closed allowing C_1 to charge to 10 V. Switch A is opened and switch B is closed allowing C_1 to discharge through R_1 . When the counter has counted the length of

time allowed by the BCD signal switch B is opened and switch C is closed. The dc voltage remaining on C_1 is transferred to holding capacitor, C_2 . From C_2 , the dc level is applied to the Modulator and the Amplitude Detector/Comparator.

4-25. The dc pretune level applied to the Modulator pretunes the amplitude of the 20 MHz signal (see Figure 4-8). The reference dc level applied to the Amplitude Detector/Comparator is compared to a detected portion of the 3330B output signal from the Output Amplifier. The difference between the detected signal and the reference dc level is applied to the Modulator as a correction voltage for the 20 MHz signal.

4-26. Digital Section.

4-27. The digital section of the 3330A/B consists of the front panel keyboard and slide switches, the display, the Remote Input/Output, the Sweep Generator, and the Control circuits. Discussion of the Control circuits begins with Paragraph 4-31. For the following descriptions of the keyboard, slide switches, and display, refer to Figures 7-6 and 7-7.

4-28. Keyboard. The front panel keyboard supplies the controller with an octal code representing the operation programmed (see Table 4-1). These binary coded outputs are provided by two 8-bit counters which count the pulses from a free-running clock, shown in Schematic No. 1, Figure 7-6. The counter outputs are also the selecting inputs to a decoder and a data selector. The eight decoder output lines and the eight data selector input lines form an 8-by-8 matrix for the keyboard. When a key is pressed, the matrix connection provided by that key stops the clock when the counter output reaches the octal code for the selected operation. When the clock stops, a one-shot output pulse indicates to the controller that the keyboard output data (from the counters) is valid. During remote operation, the clock is stopped, disabling the keyboard.

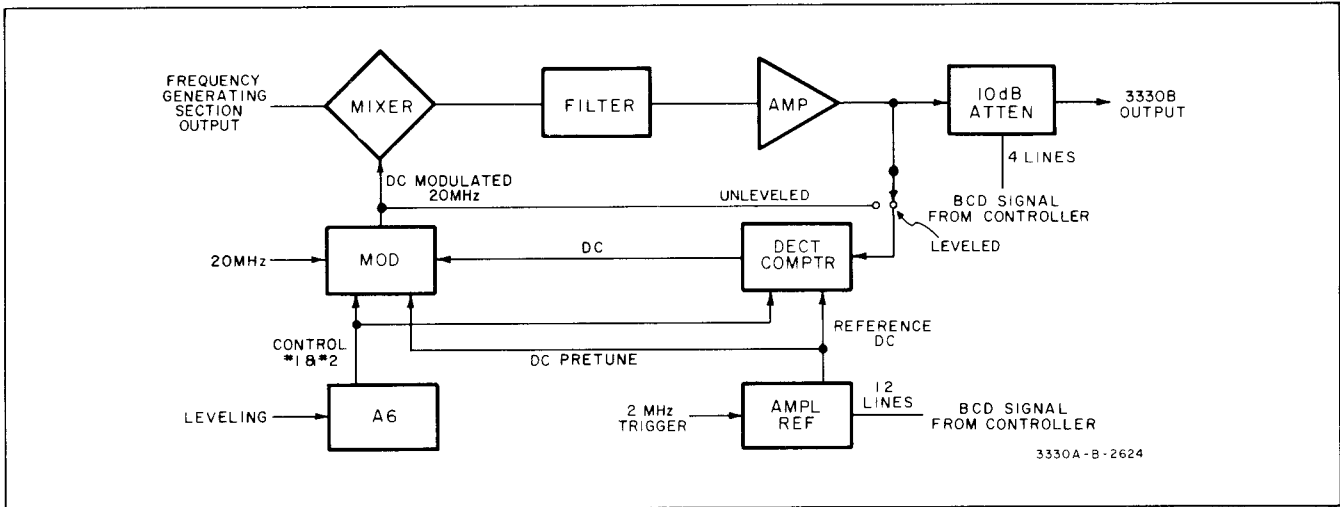

Figure 4-8. 3330B Amplitude.

4-29. Slide Switches. There are eight signal lines applied to the controller from the slide switches. These lines are either grounded or held at +5 V dc depending on the position of the slide switch. A strobe pulse from the slide switches is applied to a flag circuit. This flag indicates to the controller that information is available on the slide switches. Figure 4-9 shows the timing sequence of the flag.

4-30. Display. There are a total of 60 signal lines applied to the display from the controller. An 8-4-2-1 BCD signal (positive true logic) is applied to 32 of these lines for the frequency and amplitude digits. The decimals, overrange, and amplitude polarity lines signal levels are given in Table 4-2. The enunciators receive a 1-0 (negative true logic) signal which illuminates specific light emitting diodes.

4-31. CONTROL CIRCUITS.

4-32. The Digital Input Assembly, the Digital Output Assembly, the Controller, and the Control Processing Unit make up the 3330A/B control circuits. The control circuits must accept digital instructions from the front panel or from remote control, interpret these instructions, and provide signals which control the 3330A/B frequency, ampli-

tude, sweep, step functions, and display. A block diagram and schematic diagrams of the control circuits will be found in Figures 7-29 through 7-34.

4-33. Controller.

4-34. The Controller must provide detailed instructions that control each step of the operation. Correct timing of these instructions is essential. For example, if an operation requires that the binary information in the A register be transferred to memory, the Controller must provide simultaneous instructions to shift the data out of the A register into the proper bus system, address the correct memory register, and enter the data into the memory. The registers and the data buses are a part of the Control Processing Unit to be considered later.

4-35. Read Only Memory. The Read Only Memory (ROM) is the basic block of the Controller. A ROM is a type of memory from which data can be read out but not written

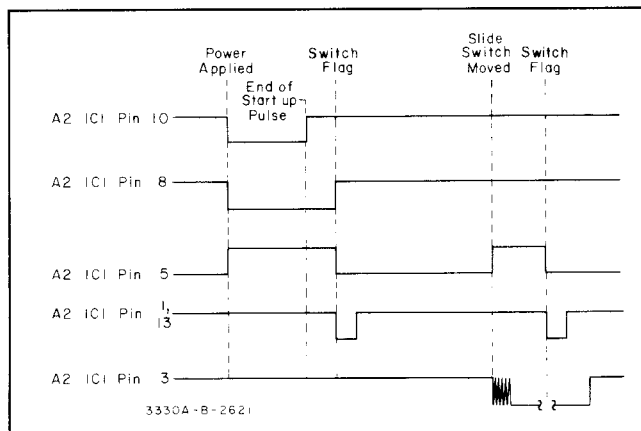

Figure 4-9. Slide Switch Strobe Timing Diagram.

Table 4-1. Keyboard Output Codes.

Key	Code	Key	Code
Freq.	14	+ dBm	73
Freq. Step	15	- dBm	74
Ampl.	16	Freq. Step X10	40
Ampl. Step	17	Freq. Step ÷ 10	41
0	60	Freq. Step X2	44
1	61	Freq. Step ÷ 2	45
2	62	Ampl. Step X10	42
3	63	Ampl. Step ÷ 10	43
4	64	Ampl. Step X2	46
5	65	Ampl. Step ÷ 2	47
6	66	Freq. ↑	52
7	67	Freq. ↓	53
8	70	Ampl. ↑	51
9	71	Ampl. ↓	50
.	72	Stop	30
Hz	75	START Cont	31
kHz	76	START Single	33
MHz	77	First Point	32

Table 4-2. Display Signal Levels.

Lines	A3P1: 22, 23, 24, 26, 30, 31, 32	A3P1 21	A3P1 33	A3P1 34
decimal on	0 V			
decimal off	+ 5 V			
overrange		0 V		
no overrange		+ 5 V		
amplitude +			+ 2 V	+ 2 V
amplitude -			+ 5 V	+ 2 V

into. It is programmed by the manufacturer according to the specifications required by the designer of the circuit in which it is to be used. In a sense, a ROM can be considered a decoder that transforms input patterns into specific output instructions. The input pattern is referred to as the "address" and the resulting output instructions are called a "word". A simplified diagram of a ROM is shown in Figure 4-10 with its truth table. In this example we have a ROM capable of accepting eight 3-bit addresses and outputting eight 4-bit words. In this simplified ROM, the input address selects and applies + 5 V to one of eight horizontal lines. This voltage is transferred to the output lines through the matrix diodes.

4-36. ROM Address. The 3330A/B Read Only Memory actually consists of twelve ROM's, each of which has eight input lines and four outputs. Since there are eight input lines, there are 2^8 or 256 different addresses. Each address is applied to all twelve ROM's simultaneously. As an example, Table 4-3 is a partial bit list for A8U1. Complete bit lists for all ROM's are given in Section VII. For convenience, the 8-bit binary address is usually given in octal code, as shown in Table 4-3. The octal code is derived from the binary address as follows:

Address bit:	RA7	RA6	RA5	RA4	RA3	RA2	RA1	RA0
Weight:	200	100	40	20	10	4	2	1
Binary:	1	0	1	0	0	1	1	0
Octal:	2		4			6		

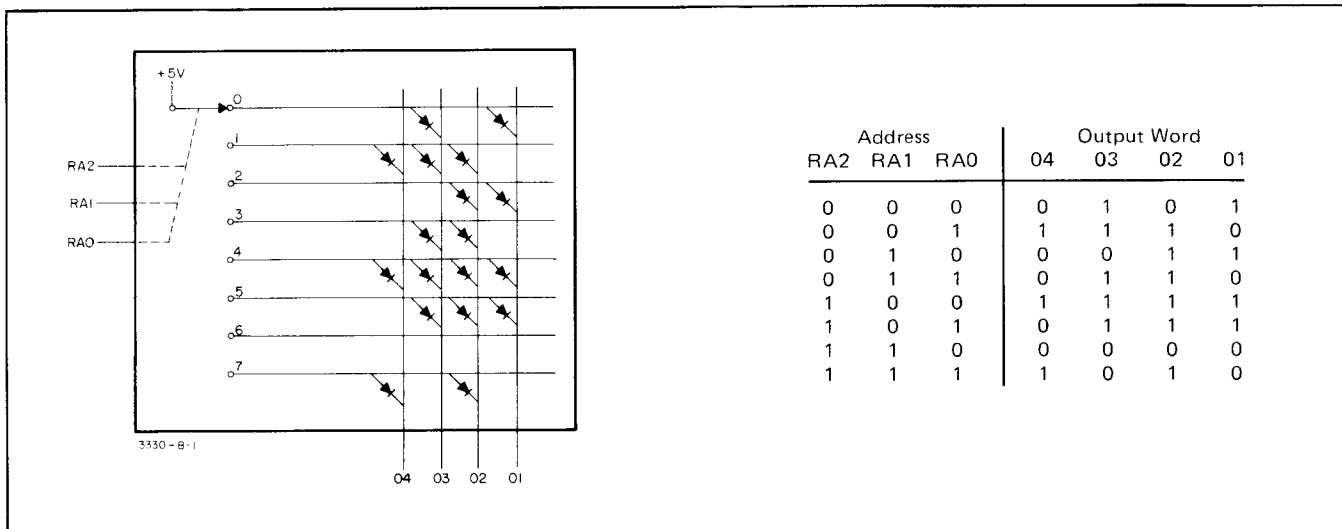

Figure 4-10. Simplified ROM Diagram.

Table 4-3. Partial Bit List for A8U1.

Octal	Address 37								Output			
	A7	A6	A5	A4	A3	A2	A1	A0	O4	O3	O2	O1
000	0	0	0	0	0	0	0	0	1	1	1	1
001	0	0	0	0	0	0	0	1	1	1	1	1
002	0	0	0	0	0	0	1	0	1	1	0	1
003	0	0	0	0	0	0	1	1	1	1	1	1
004	0	0	0	0	0	1	0	0	0	0	1	1
005	0	0	0	0	0	1	0	1	1	1	0	1
006	0	0	0	0	0	1	1	0	1	1	0	1
007	0	0	0	0	0	1	1	1	1	1	0	1
010	0	0	0	0	1	0	0	0	1	1	1	1
011	0	0	0	0	1	0	0	1	1	1	1	1

1 = High
0 = Low

4-37. Logic State. The input/output condition of the Read Only Memory at any given time is referred to as the "state". In order to identify a state, it is given the octal number of the input address. Since there are 256 possible states, some method is needed to change from one state to another. It would be possible to use a sequential counter to step the ROM through each state, but this is not practical because the 3330A/B needs the ability to branch, or to go to any state at random, or to repeat a state or series of states. Consequently the controller uses ROM outputs to determine the next state, as illustrated in Figure 4-11. This is a basic illustration, wherein the address of the present state is output from Address Storage to the ROM. The ROM output pattern (next address) is applied to the Address Storage inputs. The next clock pulse then transfers the next address to the storage outputs and ROM inputs "changing the state" of the ROM, resulting in a new output pattern.

4-38. Flowchart. In order to understand how the Controller gets from one state to another, it is necessary to understand the basic flowchart concept. A flowchart is a step-by-step description of how the control circuits work. The flowchart is also an important service tool because it gives the address, instructions, qualifier, and time interval for each state. Figure 4-12 is a small portion of the flowchart which illustrates the information available. Each rec-

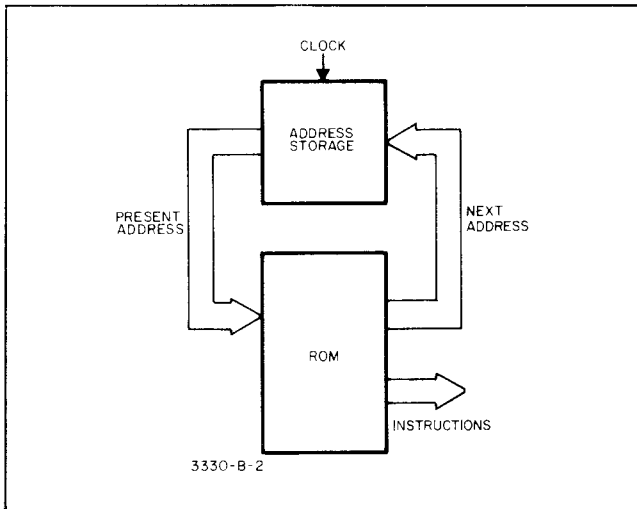

Figure 4-11. Basic ROM Address.

tangle represents a state where specific operations may be performed. The present state address is located outside the block near the upper right-hand corner. The number inside the upper right-hand corner indicates the time interval for that state; that is, the number of Register Clock cycles. This number is governed by the operations that must be accomplished during the state. The block also contains the mnemonic names for instructions that are given during that state. A dictionary of the mnemonics used in the 3330A/B may be found in Section VII.

4-39. Qualifiers. The diamond shaped block directly below the rectangle in the flowchart contains the qualifier that is tested in that state. If the qualifier is met (1) the controller follows one path, and if it is not met (0) the controller follows another path. The qualifier may be a “flag” which is set to indicate to the controller that a certain function is to be performed. For instance, if the front panel “Start Single” pushbutton is struck in the sequence of programming, the SWP flag is set (1) to tell the controller that a sweep function is desired.

4-40. Inhibit Instructions. In order that a particular state or path may be used for more than one purpose, an “inhibit” instruction may be used. In the first example in Figure

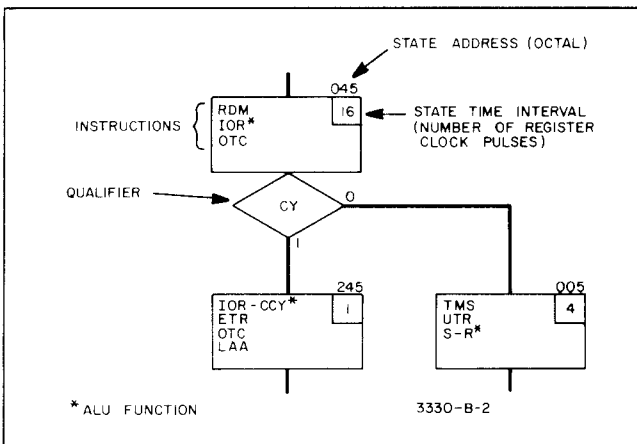

Figure 4-12. Flowchart Example.

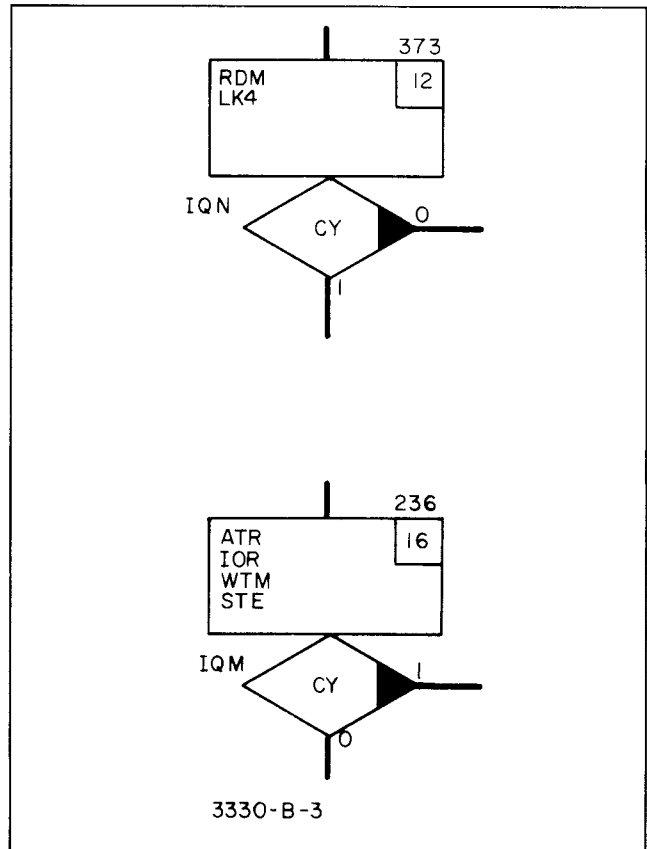

Figure 4-13. Inhibit Instructions.

4-13, the instructions contained in state 373 are inhibited (not given) if the qualifier CY is not met (0). They are carried out if the qualifier is met (1). In the second example, the instructions are inhibited if the qualifier is met. The inhibit instructions are ROM outputs IQM (Inhibit if Qualifier Met) and IQN (Inhibit if Qualifier Not Met). If the shaded portion of the diamond is at the 1 exit, this indicates an IQM instruction, and if the shaded portion is at the 0 exit, an IQN instruction is indicated.

4-41. Address Selection. Figure 4-14 is an expansion of the ROM address illustration in Figure 4-11. As the function table in the upper left part of the figure indicates, one of three possible addresses may be selected, depending on the levels of the qualifier and LAA inputs to the multiplexer. Referring back to the flowchart example in Figure 4-12, note that from state 045 the ROM may go to state 245 or 005. In this case, the level of the qualifier determines the next state. The address selected when the qualifier is 0 is the Direct Address, and the address when the qualifier is 1 is the Indirect Address. Now look at the binary bit pattern of both of these addresses:

$$Q = 0 - 005 = 0\ 0\ 0\ 0\ 0\ 1\ 0\ 1$$

$$Q = 1 - 245 = 1\ 0\ 1\ 0\ 0\ 1\ 0\ 1$$

The four least significant bits of both addresses are the same. These four bits are referred to as the Primary Address and go directly from the ROM to Address Storage, as

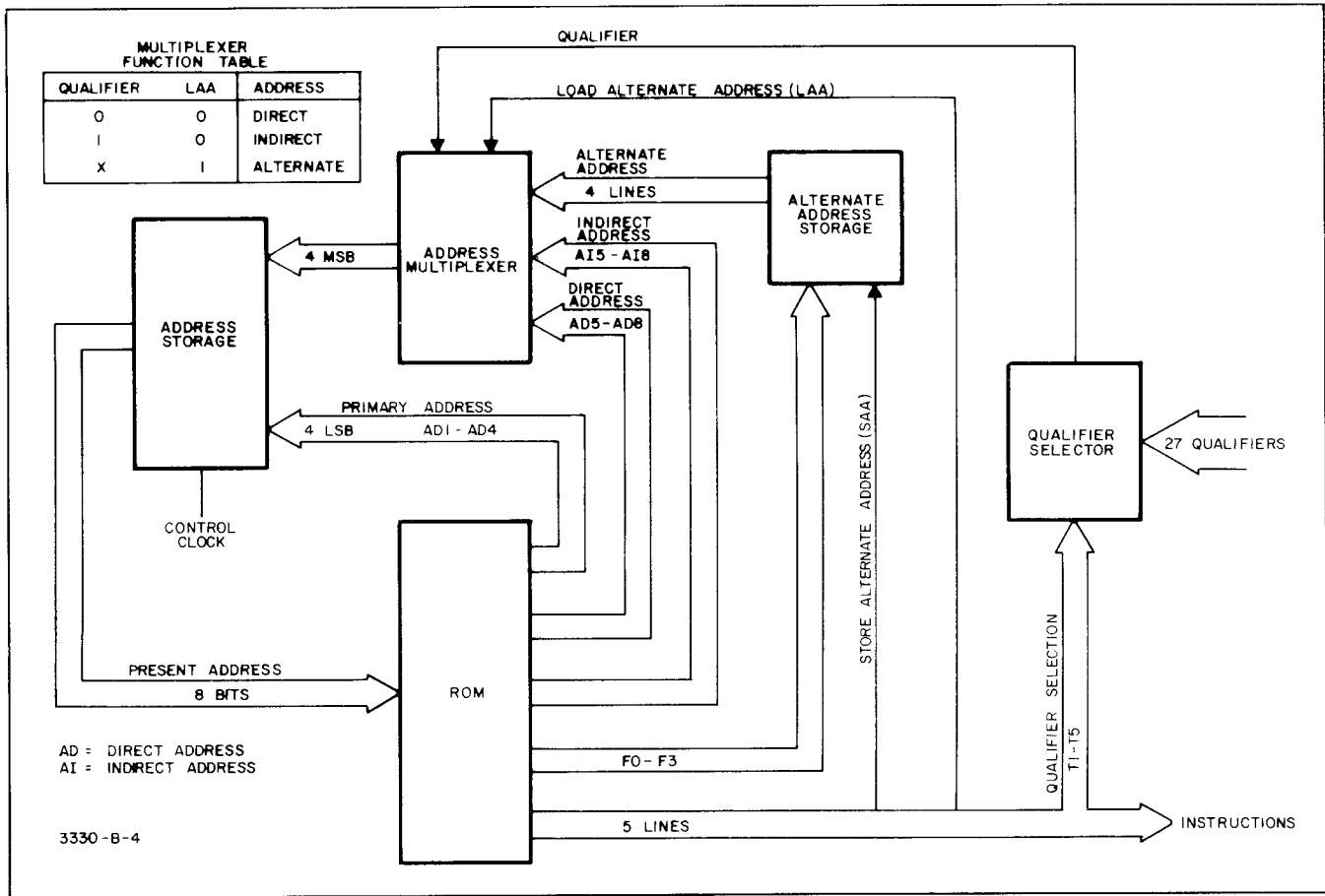

Figure 4-14. Address Selection.

shown in Figure 4-14. The four most significant bits go through the Address Multiplexer. The four most significant bits for address 005 are called the Direct Address, and these four bits for address 245 are the Indirect Address.

4-42. Alternate Address. The Alternate Address (Figure 4-14) is also just the four most significant digits of the ROM address, which are combined with the Primary Address (four least significant bits) to make up the complete address. These four bits are placed on the output lines of the Alternate Address Storage by the SAA (Store Alternate Address) instruction from the ROM. The LAA (Load Alternate Address) instruction selects the Alternate Address output from the multiplexer.

4-43. Clock Generator.

4-44. Two clock signals are generated. The Control Clock (CC) is used to clock the ROM Address Storage and ROM instruction decoding, and the Register Clock (RC) times the data flow in the Control Processing Unit registers. Figure 4-15 shows the clock outputs and timing.

4-45. Control Processing Unit.

4-46. Arithmetic Logic Unit. This unit (ALU) is a ROM that is programmed to perform addition, subtraction, and

some basic logic functions. The ALU functions are controlled by the AL2, AL1, and AL0 instructions from the Controller ROM, as shown in Table 4-4. Serial data is input to the ALU on the R Bus and the S Bus, and output on the T Bus. The carry output controls a J-K flip-flop, and the flip-flop output, CY, is used as a ROM qualifier, as well as an input to the ALU. The UTR instruction from the controller overrides the R Bus input to the ALU and forces the internal R line of the ALU to a logical 1. The UTR instruction may be used with any of the ALU functions.

4-47. A Register. This 16-bit shift register accepts serial information, or it may be parallel loaded. The output is serial, and is shifted out by the ATR (A register to R Bus) instruction. The data is recirculated in the register in the absence of a TTA instruction. TTA (T Bus to A register) shifts data from the T Bus into the A register and shifts data in the register from the most significant bit location toward the least significant bit. The parallel data input is determined by the Amplitude Constant slide switches on the CPU printed circuit assembly, A7 (see schematic, Figure 7-33), and is used in controlling the 3330A/B output amplitude and amplitude display.

4-48. K Register. This 4-bit shift register is normally parallel loaded by the LK (Load K) instruction, which enters the ROM D outputs into the K register. This unit is designed

with parallel outputs, but in practice only the least significant bit is used as a serial output. The KTR (K register to R Bus) instruction shifts data out. The data is also recirculated into the serial input by the KTR instruction. K register data is used, for example, to load a number into a Random Access Memory register.

not parallel loaded in the same manner as the K register. Instead, a PTR (P register to R Bus) instruction at the Load input recirculates data in the register, in the absence of a TTP instruction. The TTP (T Bus to P Register) instruction shifts T Bus data into the serial input and shifts data out of the least significant bit to the R Bus.

4-49. P Register. This integrated circuit unit is the same as the one used for the K register. However, the P register is

4-50. Q Register. This 8-bit shift register has both serial and parallel inputs, and parallel output. Parallel input data

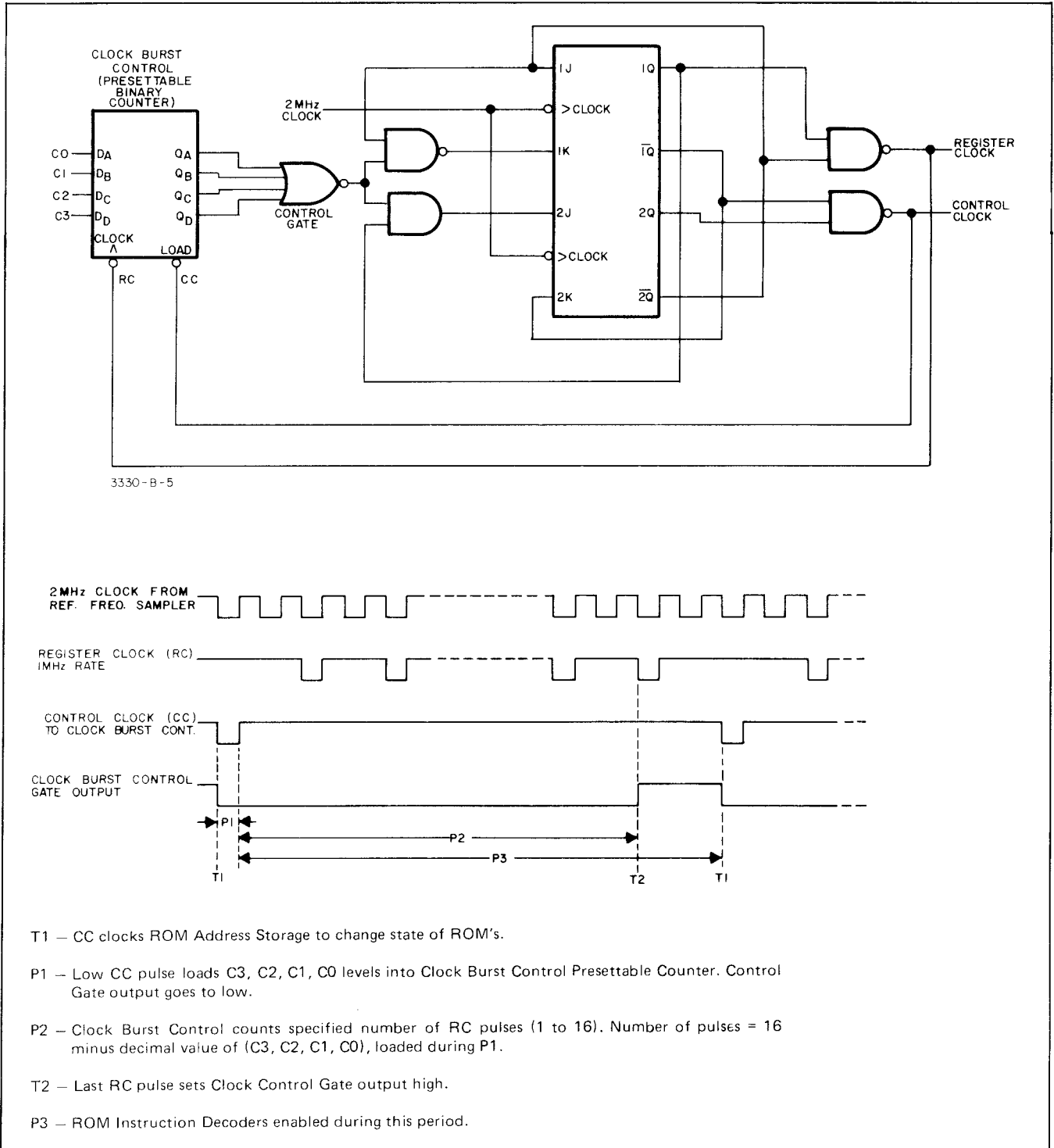



Figure 4-15. Clock Generator.

Table 4-4. ALU Functions.

AL2	AL1	AL0	Mnemonic	Function																																													
0	0	0		No Operation																																													
0	0	1	IOR	Inclusive OR $T = R + S$ 																																													
0	1	0	XOR	Exclusive OR $T = R\bar{S} + \bar{R}S$ 																																													
0	1	1	R-S	Subtract S Bus from R Bus <table border="1" style="margin-left: auto; margin-right: auto;"> <thead> <tr> <th>Carry (Borrow) In</th> <th>R</th> <th>S</th> <th>T</th> <th>Carry (Borrow) Out</th> </tr> </thead> <tbody> <tr><td>0</td><td>0</td><td>0</td><td>0</td><td>0</td></tr> <tr><td>0</td><td>0</td><td>1</td><td>1</td><td>1</td></tr> <tr><td>0</td><td>1</td><td>0</td><td>1</td><td>0</td></tr> <tr><td>0</td><td>1</td><td>1</td><td>0</td><td>0</td></tr> <tr><td>1</td><td>0</td><td>0</td><td>1</td><td>0</td></tr> <tr><td>1</td><td>0</td><td>1</td><td>0</td><td>0</td></tr> <tr><td>1</td><td>1</td><td>0</td><td>0</td><td>0</td></tr> <tr><td>1</td><td>1</td><td>1</td><td>1</td><td>0</td></tr> </tbody> </table>	Carry (Borrow) In	R	S	T	Carry (Borrow) Out	0	0	0	0	0	0	0	1	1	1	0	1	0	1	0	0	1	1	0	0	1	0	0	1	0	1	0	1	0	0	1	1	0	0	0	1	1	1	1	0
Carry (Borrow) In	R	S	T	Carry (Borrow) Out																																													
0	0	0	0	0																																													
0	0	1	1	1																																													
0	1	0	1	0																																													
0	1	1	0	0																																													
1	0	0	1	0																																													
1	0	1	0	0																																													
1	1	0	0	0																																													
1	1	1	1	0																																													
1	0	0	ADD	Add R Bus and S Bus <table border="1" style="margin-left: auto; margin-right: auto;"> <thead> <tr> <th>Carry In</th> <th>R</th> <th>S</th> <th>T</th> <th>Carry Out</th> </tr> </thead> <tbody> <tr><td>0</td><td>0</td><td>0</td><td>0</td><td>0</td></tr> <tr><td>0</td><td>0</td><td>1</td><td>1</td><td>0</td></tr> <tr><td>0</td><td>1</td><td>0</td><td>1</td><td>0</td></tr> <tr><td>0</td><td>1</td><td>1</td><td>0</td><td>1</td></tr> <tr><td>1</td><td>0</td><td>0</td><td>1</td><td>0</td></tr> <tr><td>1</td><td>0</td><td>1</td><td>0</td><td>0</td></tr> <tr><td>1</td><td>1</td><td>0</td><td>0</td><td>0</td></tr> <tr><td>1</td><td>1</td><td>1</td><td>1</td><td>0</td></tr> </tbody> </table>	Carry In	R	S	T	Carry Out	0	0	0	0	0	0	0	1	1	0	0	1	0	1	0	0	1	1	0	1	1	0	0	1	0	1	0	1	0	0	1	1	0	0	0	1	1	1	1	0
Carry In	R	S	T	Carry Out																																													
0	0	0	0	0																																													
0	0	1	1	0																																													
0	1	0	1	0																																													
0	1	1	0	1																																													
1	0	0	1	0																																													
1	0	1	0	0																																													
1	1	0	0	0																																													
1	1	1	1	0																																													
1	0	1	S-R	Subtract R Bus from S Bus <table border="1" style="margin-left: auto; margin-right: auto;"> <thead> <tr> <th>Carry (Borrow) In</th> <th>R</th> <th>S</th> <th>T</th> <th>Carry (Borrow) Out</th> </tr> </thead> <tbody> <tr><td>0</td><td>0</td><td>0</td><td>0</td><td>0</td></tr> <tr><td>0</td><td>0</td><td>1</td><td>1</td><td>0</td></tr> <tr><td>0</td><td>1</td><td>0</td><td>1</td><td>1</td></tr> <tr><td>0</td><td>1</td><td>1</td><td>0</td><td>0</td></tr> <tr><td>1</td><td>0</td><td>0</td><td>1</td><td>0</td></tr> <tr><td>1</td><td>0</td><td>1</td><td>0</td><td>0</td></tr> <tr><td>1</td><td>1</td><td>0</td><td>0</td><td>0</td></tr> <tr><td>1</td><td>1</td><td>1</td><td>1</td><td>0</td></tr> </tbody> </table>	Carry (Borrow) In	R	S	T	Carry (Borrow) Out	0	0	0	0	0	0	0	1	1	0	0	1	0	1	1	0	1	1	0	0	1	0	0	1	0	1	0	1	0	0	1	1	0	0	0	1	1	1	1	0
Carry (Borrow) In	R	S	T	Carry (Borrow) Out																																													
0	0	0	0	0																																													
0	0	1	1	0																																													
0	1	0	1	1																																													
0	1	1	0	0																																													
1	0	0	1	0																																													
1	0	1	0	0																																													
1	1	0	0	0																																													
1	1	1	1	0																																													
1	1	0	EQ	Equal <table border="1" style="margin-left: auto; margin-right: auto;"> <thead> <tr> <th>R</th> <th>S</th> <th>T</th> <th>CY</th> </tr> </thead> <tbody> <tr><td>0</td><td>0</td><td>0</td><td>0</td></tr> <tr><td>0</td><td>1</td><td>0</td><td>1</td></tr> <tr><td>1</td><td>0</td><td>0</td><td>1</td></tr> <tr><td>1</td><td>1</td><td>0</td><td>0</td></tr> </tbody> </table>	R	S	T	CY	0	0	0	0	0	1	0	1	1	0	0	1	1	1	0	0																									
R	S	T	CY																																														
0	0	0	0																																														
0	1	0	1																																														
1	0	0	1																																														
1	1	0	0																																														
1	1	1	IOR-CCY	Inclusive OR - Clear Carry $T = R + S$ $CY = 0$																																													

comes from the front panel slide switches and is entered by the ISW (Input Switch) instruction. Serial input data is from the T Bus and is shifted in by the TTQ (T Bus to Q register instruction. The QTS (Q register to S Bus) instruction shifts out the least significant bit (Q0) to the S Bus. Parallel outputs Q0 through Q5 are used as ROM address qualifiers. The Q0 input is also used to indicate whether the operation in process is an amplitude or frequency operation. Q5, Q6, and Q7 are used to control the Sweep Step Timer, in response to the setting of the Time/Step switch (or remote programming).

4-51. Extend Register. The Extend Register is a single J-K flip-flop. Its J input is the T Bus, and it is clocked by the TTE (T Bus to Extend Register) instruction. The Extend Register is made necessary because the maximum frequency of the 3330A/B is greater than 9,999,999.9 Hz. The extra bit required for the "1" in frequencies of 10 MHz and above is obtained from the Extend Register.

4-52. M Register. The M register is used primarily for access to the Random Access Memory. It is a 4-bit shift register of the same type used for the K and P Registers. The TMS (T Bus to M Register to S Bus) instruction shifts serial data from the T Bus into the M register and from the least significant bit of the M register to the S Bus. The ROM D outputs are parallel loaded into the M register by the GT (Go To) instruction. In the flowcharts, Figures 7-35 through 7-39, the GT instruction is followed by a two-digit number. This is an octal number and is the memory location to be selected by the M register parallel outputs.

4-53. Random Access Memory. The Random Access Memory (RAM) consists of two shift register units capable of storing eight 16-bit words each. The M Register outputs select the memory location, shown on the flowcharts in octal code. For example, the GT 13 instruction sets M3, M2, M1, M0 equal to 1011. Locations 00 through 07 are in A7U23 and locations 10 through 17 are in A7U24. The WTM (Write Memory) instruction shifts data from the T Bus into the memory location selected, and the RDM (Read Memory) instruction shifts data out to the S Bus. Data is also recirculated in the memory by the RDM instruction.

4-54. Sweep Step Timer. The Register Clock frequency is divided as necessary in the Sweep Step Timer to provide the time per step selected. The division rate is controlled by the Q7, Q6, and Q5 outputs from the Q register. The Timer is enabled to count by the STT (Start the Timer) instruction.

4-55. Input Circuits.

4-56. Input Data. Octal coded data from the front panel keyboard is input to the Local/Remote Data Multiplexer on six lines as explained in Paragraph 4-28. The code for each key, shown in Table 4-1, is the same as the code required for remote programming, shown in Table 3-1, except that the remote programming is 3-digit octal code and is input on seven lines. The Data Multiplexer selects the remote data

input when the REN (Remote Enable) line is low. REN low also disables the front panel slide switches.

4-57. Parallel/Serial Data Conversion. Input data is parallel loaded into a shift register and is output serially, beginning with the least significant bit. Data is shifted out by the ITS (Input to S Bus) instruction. The data is recirculated in the Input Register.

4-58. Remote Programming. The 3330A/B can be programmed remotely only after it has been addressed to listen by the system controller. When both the REN (Remote Enable) and ATN (Attention) lines have been set to the low state by the system controller, the Address Detection and Listen Flip-Flop circuits are enabled. The Address Detection gates compare a received parallel data character to a pre-determined address. If the character is the 3330A/B listen address, the Listen Flip-Flop is set to enable the logic circuits to accept and process the remote programming data. While REN is low, the 3330A/B is enabled to handshake in an HP-IB system.

4-59. Isolated Remote. Option 004 provides photo-isolation on all remote data input, HP-IB management, and handshake lines.

4-60. Output Circuits.

4-61. Output Register. The Output Register consists of four 8-bit shift registers and a D flip-flop which accept the required 33 bits of data. Serial data is shifted from the T Bus into the Output Register by the TTO (T Bus to Output) instruction. Data from the parallel outputs of the Output Register is applied to the display and to the Frequency and Amplitude Data Registers. Another set of outputs goes to the Sweep Generator.

4-62. Amplitude Data Register. Data is latched into the Amplitude Data Register by the OTAC (Output to Amplitude Control) instruction. The register outputs are applied to the Amplitude Reference circuits (A26) and the Attenuator (A31).

4-63. Frequency Data Register. Data is latched into the Frequency Data Register by the OTFC (Output to Frequency Control) instruction. This data is then applied to the N1 through N4 VTO's and N1 through N4 Counter Samplers.

4-64. Decimal Register. One of eight decimal positions is stored in the Decimal Register by the OTDL (Output to Decimal Latch) instruction. This data is used to light the display decimal point and is also used in the non-significant zero blanking circuits.

4-65. Non-Significant Zero Blanking. The blanking circuits are designed so that any zero in the display (except the least significant digit) will be blanked unless there is a decimal point or another lighted digit to its left.

WARNING

These servicing instructions are for use by qualified personnel only. To avoid electrical shock, do not perform any servicing other than that contained in the operating instructions unless you are qualified to do so.

Table 5-1. Test Equipment Required.

Instrument Type	Required Characteristics	Recommended Model
Wave Analyzer	Frequency: 1 kHz to 18 MHz Amplitude: 100 μ V to 2 V Output: recorder at 1 V dc full scale	-hp- Model 312B
Spectrum Analyzer	Frequency: to \geq 50 kHz	-hp- Model 3580A or -hp- Model 8553B/ 8552A (in 141T display)
Oscilloscope	Dual Channel (Chan B trigger) Frequency: dc to 50 MHz	-hp- Model 180C (with 1801A and 1820C plug-ins).
Oscillator	Signal to Noise Ratio: > 60 dB down Spurious: > 80 dB down Frequency: 5 MHz and 1 MHz	-hp- 105A/B
AC Voltmeter	Range: 100 mV rms to 10 V rms full-scale Resolution: 100 μ V rms on 1 V rms range Frequency: 50 Hz to 10 kHz	-hp- Model 3450B
Voltmeter	Dynamic Range: 100 dB Frequency: 10 kHz	-hp- Model 403B
dc Voltmeter	Range: 100 mVdc to 50 Vdc Resolution: 1 μ Vdc on 100 mVdc range 100 μ Vdc on 1 Vdc range. Accuracy: .007% on 100 mVdc range, .05% all other ranges.	-hp- Model 3450B
Electronic Counter	Frequency: dc to 33 MHz 8 digit display	-hp- 5245L
Attenuator	Attenuation: 20 dB in 10 dB steps Accuracy: \pm 0.01 dB	-hp- Model 355D with known error
Attenuator	Attenuation: 10 dB in 1 dB steps	-hp- Model 355C
Thermocouple	Input: 1 V rms and 3 V rms Output: 7.0 mVdc Input Impedance: 50 ohms and 75 ohms	-hp- Model 11050A -hp- Model 11050-H01 (for Option 001) -hp- Model 11049 (for Option 005)
Double Balanced Mixer	Frequency: 100 kHz to 13 MHz Impedance: 50 ohm	-hp- Model 10534A
Frequency Doubler	Frequency: 5 MHz Impedance: 50 ohm	-hp- Model 10515A
Low Pass Filter	Frequency: 150 kHz	see Figure 5-2
Low Pass Filter	Frequency: 15 kHz	see Figure 5-2
Feed-thru Termination	Impedance: 50 ohm \pm 0.2% 75 ohm \pm 0.2%	-hp- Model 11048C -hp- Model 11094C
Resistors	100 ohm (1 ea) 10 kilohm (1 ea)	-hp- Part No. 0757-0178 -hp- Part No. 0757-0340
Capacitors	.0068 μ F (1 ea) 1300 pF (1 ea) .012 μ F (1 ea) 1600 pF (1 ea)	-hp- Part No. 0160-0159 -hp- Part No. 0160-2221 -hp- Part No. 0160-0301 -hp- Part No. 0160-2223
Peak Detector Probe	Voltage Range: 5 V rms Accuracy: \pm 5% Frequency: 100 kHz to 13 MHz	-hp- 11096A
Logic State Analyzer	8-bit word plus 1 qualifier. Delay preset.	-hp- Model 1601A (for 180C Oscilloscope)

SECTION V MAINTENANCE

5-1. INTRODUCTION.

5-2. This section contains the information necessary for maintenance of the Model 3330A/B Automatic Synthesizer. Included is a list of test equipment required, in-cabinet performance tests, and adjustment procedures.

5-3. TEST EQUIPMENT.

5-4. The test equipment required for the maintenance of

the 3330A/B is listed in Table 5-1. If the recommended model is not available, use a substitute that meets the required characteristics.

5-5. WARM-UP PERIOD.

5-6. To insure proper stabilization of all circuitry, allow a 30 minute warm-up period before beginning any performance checks or adjustment procedures.

PERFORMANCE CHECKS

5-7. INTRODUCTION.

5-8. The following performance checks compare the 3330A/B with the list of specifications given in Table 1-1. These checks may be used for incoming inspection, periodic maintenance, or to verify specifications after repair. A Performance Check Test Card is provided at the end of this section for recording the performance of the instrument during the performance checks. The card may be removed from the manual as a permanent record. If the instrument fails to meet any of its specifications, perform the adjustment procedures outlined in Paragraph 5-25. During the performance checks, periodically vary the line voltage (115 V or 230 V) \pm 10% with a power line transformer to insure proper operation at various ac line voltages. When checking the performance of the Option 001 (75 ohm) 3330A/B, use a 75 ohm to 50 ohm adapter on the output of the 3330A/B (excluding Paragraphs 5-15 and 5-17). Refer to Figure 5-7 for part numbers and diagram of 50 ohm to 75 ohm adapter.

5-9. Harmonic Distortion.

5-10. This test compares the performance of the 3330A/B to the Harmonic Distortion specifications listed in Table 1-1. The specifications are divided into three frequency ranges: - 60 dB from 5 Hz to 100 kHz, - 50 dB from 100 kHz to 1 MHz, and - 40 dB from 1 MHz to 13 MHz. This procedure uses an -hp- Model 3580A Spectrum Analyzer (range: 5 Hz to 50 kHz) to check the lower frequencies, and an -hp- Model 312B Frequency Selective Voltmeter (range: 1 kHz to 18 MHz) to check the higher frequencies. Harmonics can be checked at frequencies higher than 18 MHz if an analyzer having a higher frequency range

is available (such as -hp- Model 141T/8552A/8553A Spectrum Analyzer).

a. Connect the spectrum analyzer to the 3330A/B output.

b. Program the 3330A/B as follows:

```
FREQ . . . . . 100 Hz
LEVEL (3330A Std and all options) . . fully cw
AMPL (3330B Std) . . . . . + 13.44 dBm
    (Option 001) . . . . . + 11.68 dBm
    (Option 005) . . . . . + 26.99 dBm
LEVELING (3330B) . . . . . SLOW (> 10 Hz)
```

c. Adjust the spectrum analyzer to compare the second, third, and fourth harmonic levels to the level of the fundamental frequency. All harmonics should be at least 60 dB below the fundamental frequency level.

d. Repeat Step c for 3330A/B FREQUENCY settings of 1 kHz and 10 kHz. (When checking 3330B at 10 kHz and above, set LEVELING to FAST.) In both cases, harmonics should be at least 60 dB down from the fundamental level.

e. Replace the spectrum analyzer with the frequency selective voltmeter and attenuators as shown in Figure 5-1.

f. Set the 3330A/B FREQUENCY to 100 kHz.

g. Set the 355D attenuator to 10 dB (20 dB, Option 005), the 355C to 3 dB, and adjust the frequency selective voltmeter to a convenient reference level.

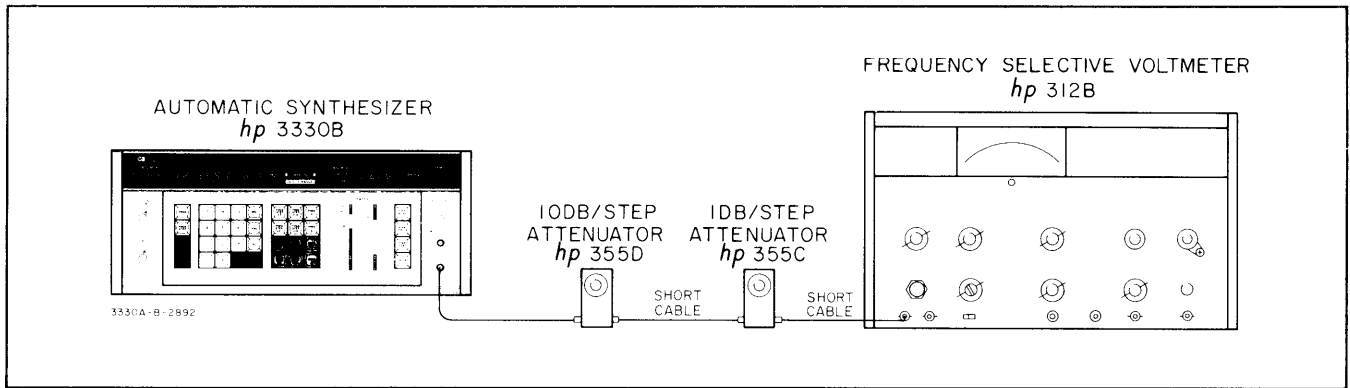

Figure 5-1. Harmonic Distortion.

h. Tune the frequency selective voltmeter to the second, third, and fourth harmonics of the 100 kHz signal. All harmonics should be at least 50 dB below the reference set in Step g.

i. Repeat Steps g and h with the 3330A/B FREQUENCY set to 1 MHz. All harmonics should be at least 40 dB below the reference set in Step g.

j. Repeat Steps g and h with the 3330A/B FREQUENCY set to 8 MHz. Note that because of the limitation of the frequency selective voltmeter, only the second harmonic can be checked. The harmonic should be at least 40 dB below the reference set in Step g.

5-11. Signal to Phase Noise.

5-12. This performance check insures the 3330A/B meets the Signal to Phase Noise specifications listed in Table 1-1. The specification for signal to phase noise is >50 dB down in a 30 kHz band, excluding ± 1 Hz centered on carrier. This check uses a 5 MHz oscillator, with a frequency

doubler, as a reference frequency. The output of the 3330A/B and the reference frequency are mixed and the difference signal is applied to a wideband ac voltmeter. When the 5 MHz oscillator is tuned slightly off frequency, the phase of the 3330A/B output signal will drift slightly. As the 3330A/B output and the reference oscillator drift through phase quadrature, the ac voltmeter will peak. This peak value is the maximum phase noise.

a. Connect the 5 MHz oscillator to a counter and adjust the frequency for 5,000,000.0 Hz.

b. Connect the equipment as shown in Figure 5-2.

c. Program the 3330A/B as follows:
 FREQ 10,010,000.0 Hz
 LEVEL (3330A Std and Option 001) . full cw
 (3330A Option 005) full cw
 AMPL (3330B Std and all options).+10.00 dBm
 LEVELING (3330B)FAST (> 1 kHz)
 REF OSC (rear panel)EXT

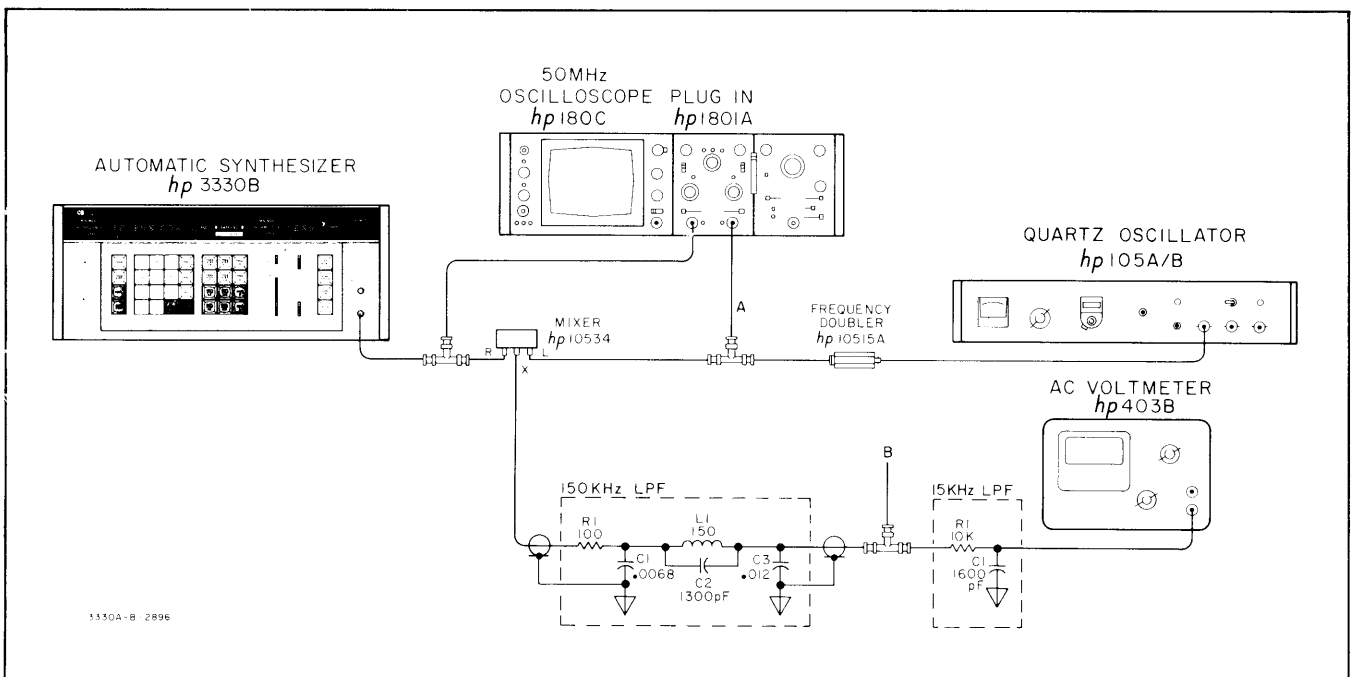

Figure 5-2. Signal to Phase Noise.



Do not exceed the rated input of the mixer.

d. Adjust the 3330A/B amplitude for a convenient reference level on the ac voltmeter. Set the oscilloscope DISPLAY for ALT B trigger and adjust for a convenient display of both channels (the Channel A signal will not lock).

e. Program the 3330A/B **FREQ** to 10,000,000.0 Hz. Adjust the frequency of the 5 MHz oscillator until the Channel A display on the oscilloscope is drifting *very* slowly.

f. Ground the Channel B input terminal on the oscilloscope and adjust the display for a convenient reference. Set the input terminal to dc.

g. Disconnect Channel B of the oscilloscope from point A (Figure 5-2) and connect to point B.

h. The oscilloscope display on Channel B should drift through 0 Vdc when the 3330A/B signal and the reference oscillator signal are in phase quadrature. The indication on the ac voltmeter, when the Channel B oscilloscope display is at 0 Vdc, should be > 50 dB below the reference set in Step d.

5-13. Spurious.

5-14. This performance test insures the 3330A/B meets the Spurious specification listed in Table 1-1. The specification for the 3330A is > 70 dB below selected output. The specification for the 3330B is > 70 dB below the selected output or - 110 dBm into 50 ohms, whichever is greater. A wave analyzer is used to check random spurious and 2, 1 spurious. The 2, 1 spurious is generated by the mixing action used to develop the 3330A/B output frequency (see Figure 5-3). The 2, 1 spurious is equal to $2F_2 - F_1$. ($F_2 = 20$ MHz from AM Board; $F_1 = 20 - 33$ MHz from SL₁). For example, if the 3330A/B is programmed for an output frequency of 8 MHz, $F_1 = 28$ MHz and $2F_2 - F_1 = 40$ MHz - 28 MHz = 12 MHz = 2, 1 spurious, 10 kHz and 60 Hz sidebands are checked at 10 MHz by mixing the 3330A/B output frequency to 100 kHz and 10 kHz and monitoring the sidebands with a wave analyzer.

a. Connect wave analyzer to the 3330A/B output. The 3590A wave analyzer with the 3594A plug-in will cover the lower frequency ranges of the 3330A/B. The 312A wave analyzer will cover the high frequency ranges.

- b. Program the 3330A/B as follows:
FREQ 13 MHz
LEVEL (3330A Std and Option 001) . full cw
 (3330A Option 005) full ccw
AMPL (3330B Std and all options).+10.00 dBm
LEVELING (3330B)FAST (> 1 kHz)

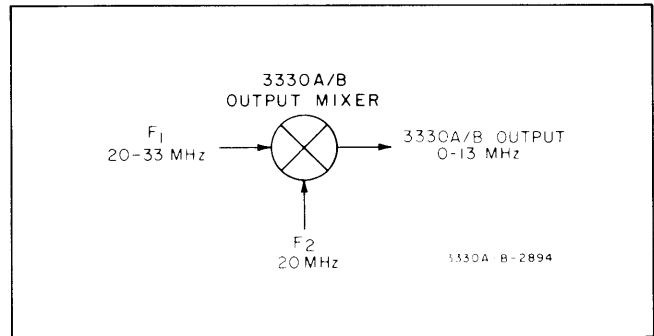

Figure 5-3. 3330 Output Section.

c. Adjust the wave analyzer for a convenient reference level on the wave analyzer meter.

d. Tune the wave analyzer through the entire frequency range of the 3330A/B. The wave analyzer meter indication should be as follows:

- 3330A - > 70 dB below the reference set in Step c.
- 3330B - > 70 dB below the reference set in Step c or - 110 dBm, whichever is greater.

NOTE

The 2, 1 spurious for a 3330A/B output frequency of 13 MHz is 7 MHz (40 MHz - 33 MHz). In Step d above, be sure to check at 7 MHz with the wave analyzer.

e. Connect the equipment as shown in Figure 5-4 (insure the 5 MHz oscillator is at 5,000,000.0 Hz).

- f. Program the 3330A/B as follows:
FREQ 10.1 MHz
LEVEL (3330A Std and Option 001) . full cw
 (3330A Option 005) full ccw
AMPL (3330B Std and all options).+10.00 dBm
LEVELING (3330B)FAST (> 1 kHz)
REF OSC (rear panel)EXT



Do not exceed the rated input of the mixer.

g. Adjust the wave analyzer for a convenient wave analyzer meter indication at 100 kHz.

h. Tune the wave analyzer to 90 kHz, 80 kHz, 70 kHz, and 60 kHz. Meter indications for the 10 kHz sidebands should be as follows:

- 3330A - > 70 dB below reference set in Step g.
- 3330B - > 70 dB below the reference set in Step g or - 110 dBm, whichever is greater.

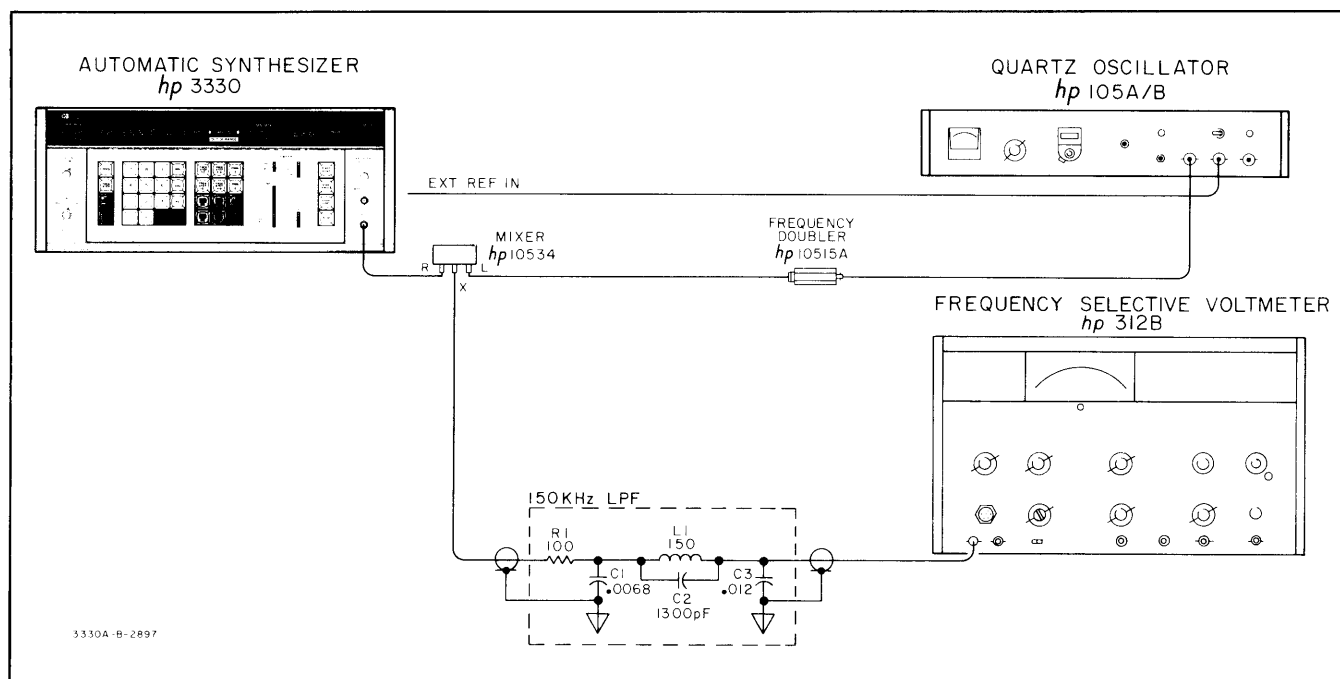

Figure 5-4. Spurious.

i. Program the 3330A/B FREQ to 10.01 MHz and repeat Step g for 10 kHz.

j. Tune the wave analyzer to 10.060 kHz, 10.120 kHz, 10.180 kHz, and 10.240 kHz. Meter indications for the 60 Hz sidebands should be as follows:

- 3330A - > 70 dB below the reference set in Step g.
- 3330B - > 70 dB below the reference set in Step g or - 110 dBm, whichever is greater.

5-15. Amplitude Accuracy (Absolute).

5-16. This performance check insures the 3330A/B meets the Amplitude specifications listed in Table 1-1. The specifications are:

3330A Standard and Option 001:

- 1 V rms \pm 10% into 50 ohms (75 ohms Option 001)
- 2 V rms \pm 10% open circuit

3330A Option 005:

- 5 V rms \pm 10% into 50 ohms
- 10 V rms \pm 10% open circuit

3330B Standard and Option 001:

- 1.05 V rms \pm 0.5% into 50 ohms (75 ohms Option 001)
- 2.1 V rms \pm 0.5% open circuit

3330B Option 005:

- 5.0 V rms \pm 0.5% into 50 ohms
- 10.0 V rms \pm 0.5% open circuit

a. Connect an ac voltmeter to the 3330A/B output through a 50 ohm load (75 ohm load, Option 001).

b. Program the 3330A/B as follows:

- FREQ 10 kHz
- LEVEL (3330A Std and all options) . . full cw
- AMPL (3330B Std) + 13.44 dBm
- (Option 001) + 11.68 dBm
- (Option 005) + 26.99 dBm
- LEVELING (3330B) FAST (> 1 kHz)

c. The ac voltmeter indication should be as follows:

3330A Std and Option 001:

1 V rms \pm 0.1 V rms.

3330A Option 005:

5 V rms \pm 0.5 V rms.

3330B Std and Option 001:

1.05 V rms \pm 0.0053 V rms.

3330B Option 005:

5.00 V rms \pm 0.025 V rms.

d. Remove the 50 ohm load (75 ohm load, Option 001). The ac voltmeter indication should be as follows:

3330A Std and Option 001:

2 V rms \pm 0.2 V rms.

3330A Option 005:

10 V rms \pm 1.0 V rms.

3330B Std and Option 001:

2.1 V rms \pm 0.0105 V rms.

3330B Option 005:

10 V rms \pm 0.05 V rms.

5-17. Frequency Response (3330A and 3330B with 10 dB Attenuator in Straight-Through Position).

5-18. This performance check compares the frequency response of the 3330A/B with its specifications in Table 1-1.

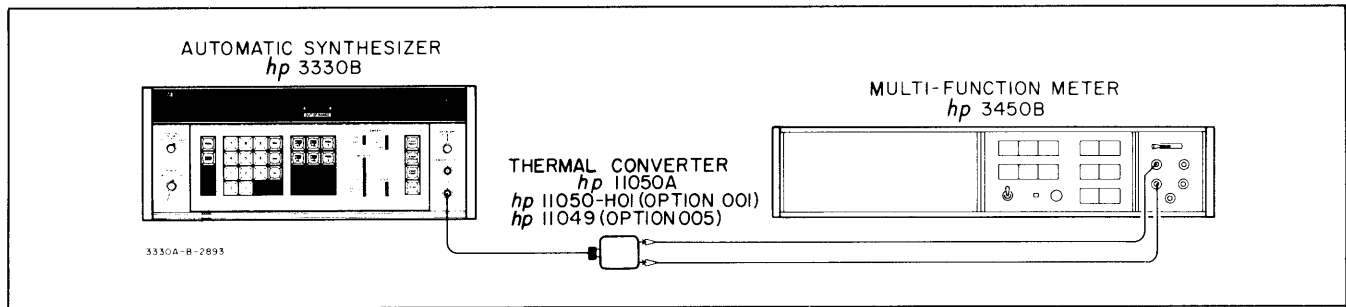

Figure 5-5. Frequency Response.

The 3330B output attenuator is in the straight-through position for this check. The specifications are as follows:

- 3330A: (10 kHz Reference) ± 0.5 dB
- 3330B: (10 kHz Reference) ± 0.05 dB

a. Connect the equipment as shown in Figure 5-5. Be sure to use the correct thermal converter.

b. Program the 3330A/B as follows:

FREQ 10 kHz
 LEVELING (3330B) FAST (> 1 kHz)



Do not exceed the rated input of the thermocouple.

c. Adjust the 3330A/B amplitude for a 7.000 mV ± 10 µV indication on the dc voltmeter. Do not make any further changes in amplitude during the remainder of this test.

d. Set the 3330A/B to the frequencies listed below. The dc voltmeter indication should not vary more than ± 700 µV for the 3330A or ± 70 µV for the 3330B.

- 100 kHz
- 1 MHz
- 2.5 MHz
- 5 MHz
- 7.5 MHz
- 10 MHz
- 13 MHz

e. Because the 3330B Attenuator Accuracy and Frequency Response tests are referenced to 1 V rather than 7 mV, the voltage differences recorded for the 3330B in Step d must be multiplied by a factor of 71.5. These adjusted errors are used in calculating the Attenuator Frequency Response errors. This factor is determined by $\frac{1 \text{ V}}{.007 \text{ V}} \div 2 \cong 71.5$. Division by 2 is required because the thermal converter is a power (square law) device. The divide by 2 is accurate if the thermal converter is used over a very small portion of its power range. Record these adjusted error voltages (see the Performance Test Card). Be sure to

record them as positive or negative with respect to the reference.

5-19. 3330B Attenuator Accuracy (10 kHz).

5-20. This performance test insures the 3330B meets the attenuator accuracy specification listed in Table 1-1. The specification is ± 0.02 dB/10 dB step, 10 kHz, referenced to the straight-through position of the output attenuator. This specification is accumulative as attenuation is added to the output. The tolerance for each added step is equal to the tolerance of the previous step plus 0.02 dB. The output of the 3330B is applied to a wave analyzer through a calibrated attenuator. The wave analyzer detects the 3330B output signal and applies the detected signal to a dc voltmeter. The dc voltmeter indications are recorded for later use in determining the 3330B output attenuator frequency response.

a. Connect the equipment as shown in Figure 5-6.

NOTE

This performance test uses a 355D 10 dB attenuator with a known accuracy on the 0dB and 10 dB settings. The error in the attenuator must be considered in determining the error of the 3330B.

b. Program the 3330B as follows:

FREQ 10 kHz
 AMPL (Std) + 13.44 dBm
 (Option 001) + 11.68 dBm
 (Option 005) + 25.00 dBm
 AMPL STEP 10.00 dBm
 LEVELING FAST (> 1 kHz)
 TIME/STEP 3000 msec

c. Set the 355D to 10 dB and adjust the 355C and the wave analyzer for a 1.000 Vdc indication on the dc voltmeter.

d. Press the AMPL ↓ key. Set the 355D to 0 dB and record the difference between the dc voltmeter indication and the reference set in Step c.

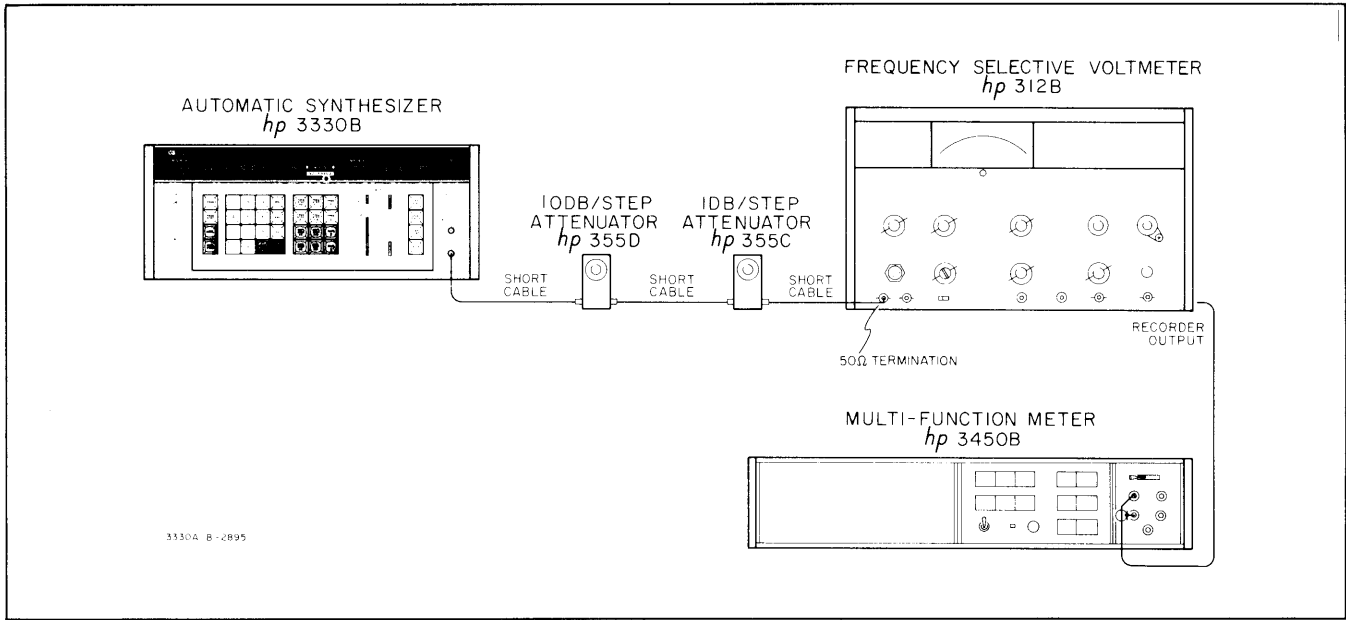

Figure 5-6. 3330B Attenuator Accuracy.

e. Set the 355D to 10 dB and down range the wave analyzer 10 dB. Adjust the 355C and the wave analyzer for a 1.000 Vdc indication on the dc voltmeter.

f. Press the AMPL ↓ key and set the 355D to 0 dB. Algebraically add the difference between the dc voltmeter indication and the reference set in Step e to the difference recorded in Step d.

g. Repeat Steps e and f for the remaining attenuator settings listed in Table 5-4. In Step f, algebraically add to the previously recorded difference instead of the difference recorded in Step d.

h. Tolerances for each position of the output attenuator are shown in Table 5-2.

10 kHz. The last three digits of amplitude (i.e., 3.44 digits in + 13.44 dBm) are controlled by electronic attenuation in the 3330B. Frequency response is not affected by this attenuation; therefore, this test evaluates only the most significant digit (10 dB attenuator). The attenuator frequency response is determined by measuring the attenuator accuracy at various frequencies, comparing these errors to the accuracy at 10 kHz (Paragraph 5-19), and adding the results to the 3330B frequency response with the 10 dB/step attenuator in the straight-through position (Paragraph 5-17). The specifications are broken into three groups with the LEVELING switch in the SLOW (> 10 Hz) or FAST (> 1 kHz) position and one specification with the LEVELING in the OFF position.

a. Connect the equipment as shown in Figure 5-6.

5-21. 3330B Output Attenuator Frequency Response.

5-22. This test compares the performance of the 3330B to its Frequency Response specification listed in Table 1-1 (repeated in Table 5-3) at all positions of its 10 dB/step output attenuator. All specifications are referenced to

NOTE

This performance test uses a 355D 10 dB attenuator with a known accuracy on the 0 dB and 10 dB settings. The error in the attenuator should be used in determining the error of the 3330B.

Table 5-2. Attenuator Accuracy Tolerances.

Attenuator (dBm)			Tolerance (mV) (accumulative)
Standard	Option 001	Option 005	
+ 3.44	+ 1.68	+ 6.99	± 2
- 6.56	- 8.32	- 3.01	± 4
- 16.56	- 18.32	- 13.01	± 6
- 26.56	- 28.32	- 23.01	± 8
- 36.56	- 38.32	- 33.01	± 10
- 46.56	- 48.32	- 43.01	± 12
- 56.56	- 58.32	- 53.01	± 14
- 66.56	- 68.32	- 63.01	± 16
- 76.56	- 78.32	- 73.01	± 18

- b. Program to 3330B as follows:
- FREQ 100 kHz
 - AMPL (Std) + 13.44 dBm
 - (Option 001) + 11.68 dBm
 - (Option 005) + 25.00 dBm
 - LEVELING FAST (> 1 kHz)
 - AMPL STEP 10.00 dBm
 - TIME/STEP 3000 msec

c. Set the 355D to 10 dB and adjust the 355C and wave analyzer for a 1.000 Vdc indication on the dc voltmeter.

Table 5-3. 3330B Frequency Response Specifications.

3330B Attenuator Setting (dBm)			Specification (dB)	
Standard	Option 001	Option 005	* Leveling OFF	Leveling SLOW (> 10 Hz) or Leveling FAST (> 1 kHz)
+ 13.44 to - 16.55	+ 11.68 to - 18.31	+ 26.99 to - 3.00	± 0.5	± 0.05
- 16.55 to - 36.55	- 18.31 to - 38.31	- 3.00 to - 23.00	± 0.5	± 0.10
- 36.55 to - 66.55	- 38.31 to - 68.31	- 23.00 to - 53.00	± 0.5	± 0.21
- 66.55 to - 86.55	- 68.31 to - 88.31	- 53.00 to - 73.00	± 0.5	± 0.40

*For frequencies above 10 Hz and Leveling in OFF position, add 0.5 dB to Leveling SLOW (> 10 Hz) or Leveling FAST (> 1 kHz) specification.

d. Press the AMPL ↓ key. Set the 355D to 0 dB and record the difference between the dc voltmeter indication and the reference set in Step c. Be sure to indicate whether the error is positive or negative with respect to the reference. This records the accuracy error for the first 10 dB step of the attenuator (see Table 5-4).

e. Repeat Steps c and d for the remainder of the attenuator steps as indicated in Table 5-4. At each setting marked (Ref), adjust the 355D and wave analyzer for a dc voltmeter indication of 1.000 V.

f. Repeat Steps c, d and e for the frequencies listed in Paragraph 5-18, Step d.

g. The attenuator frequency response is determined by using the formula $A = B + C - D$, where

- A = The relationship of the error, measured at a specific frequency and on a certain attenuator step to the 10 kHz reference.
- B = The measured error, recorded in Step d.
- C = The adjusted frequency response error measured at

Table 5-4. Output Attenuator.

3330B (dBm)			355D (dB)	Wave Analyzer (dBm)	
Standard	Option 001	Option 005		Standard and Option 001	Option 005
+ 13.44 (Ref)	+ 11.68 (Ref)	+ 26.99 (Ref)	10	0	+10
+ 3.44	+ 1.68	+ 6.99	0	Record dc Voltmeter Indication	
+ 3.44 (Ref)	+ 1.68 (Ref)	+ 6.99 (Ref)	10	- 10	0
- 6.56	- 8.32	- 3.01	0	Record Accumulative Error	
- 6.56 (Ref)	- 8.32 (Ref)	- 3.01 (Ref)	10	- 20	- 10
- 16.56	- 18.32	- 13.01	0	Record Accumulative Error	
- 16.56 (Ref)	- 18.32 (Ref)	- 13.01 (Ref)	10	- 30	- 20
- 26.56	- 28.32	- 23.01	0	Record Accumulative Error	
- 26.56 (Ref)	- 28.32 (Ref)	- 23.01 (Ref)	10	- 40	- 30
- 36.56	- 38.32	- 33.01	0	Record Accumulative Error	
- 36.56 (Ref)	- 38.32 (Ref)	- 33.01 (Ref)	10	- 50	- 40
- 46.55	- 48.32	- 43.01	0	Record Accumulative Error	
- 46.56 (Ref)	- 48.32 (Ref)	- 43.01 (Ref)	10	- 60	- 50
- 56.56	- 58.32	- 53.01	0	Record Accumulative Error	
- 56.56 (Ref)	- 58.32 (Ref)	- 53.01 (Ref)	10	- 70	- 60
- 66.56	- 68.32	- 63.01	0	Record Accumulative Error	
- 66.56 (Ref)	- 68.32 (Ref)	- 63.01 (Ref)	10	- 80	- 70
- 76.56	- 78.32	- 73.01	0	Record Accumulative Error	

the same frequency as B, on the next higher step of the attenuator. For the first step down on the attenuator, C is the adjusted error recorded in Paragraph 5-17 at the same frequency. For each succeeding step down, the calculated error A of the previous step is used for C. This is true because the attenuator error is cumulative; that is, the error on any step includes the accumulated errors of all higher steps.

D = The error at 10 kHz measured on the same attenuator step as B.

Example:

- B = + 2 mV (the recorded error at 10 MHz in Step d)
- C = - 1 mV (the adjusted error at 10 MHz on the straight-through step of the attenuator, recorded in Paragraph 5-17, Step e)
- D = - 1 mV (the error at 10 kHz measured on the first step down of the attenuator, recorded in Paragraph 5-19, Step d)
- A = 2 mV + (- 1 mV) - (- 1 mV) = 2 mV. This indicates that the output at 10 MHz is 2 mV positive with respect to the output at 10 kHz on the same attenuator step. In calculating the error on the next step down on the attenuator, C would be + 2 mV.

h. Calculate the error (A) for each step of the attenuator at each of the frequencies measured above. The frequency response tolerances, using this procedure, are as follows:

3330B Attenuator Setting (dBm)			Tolerance (mv)
Standard	Option 001	Option 005	Leveling SLOW (> 10 Hz) or Leveling FAST (> 1 kHz)
+ 13.44 to - 16.55	+ 11.68 to - 18.31	+ 26.99 to - 3.00	± 5 mV
- 16.55 to - 36.55	- 18.31 to - 38.31	- 3.00 to - 23.00	± 12 mV
- 36.55 to - 66.55	- 38.31 to - 68.31	- 23.00 to - 53.00	± 23 mV
- 66.55 to - 86.55	- 68.31 to - 88.31	- 53.00 to - 73.00	± 45 mV

5-23. Sweep Output.

5-24. This performance check insures the 3330A/B meets the Sweep Output specifications listed in Table 1-1. The specifications are:

Accuracy: ± 0.2% of full-scale

Linearity: ± 0.1% of full-scale

The accuracy specification is an absolute value for each step of the sweep output. The linearity specification determines the relationship between the steps. This performance check measures and records the absolute accuracy of each step,

Table 5-5. Sweep Output Accuracy.

Sweep Step	Specification
0	0 Vdc ± 20 mVdc
1	1 Vdc ± 20 mVdc
2	2 Vdc ± 20 mVdc
3	3 Vdc ± 20 mVdc
4	4 Vdc ± 20 mVdc
5	5 Vdc ± 20 mVdc
6	6 Vdc ± 20 mVdc
7	7 Vdc ± 20 mVdc
8	8 Vdc ± 20 mVdc
9	9 Vdc ± 20 mVdc
10	10 Vdc ± 20 mVdc

then uses the recorded measurements to determine the linearity.

- a. Connect a dc voltmeter to the 3330A/B SWEEP OUTPUT.
- b. Program the 3330A/B as follows:
 FREQ 5 MHz
 FREQ STEP 1 MHz
 SWEEP mode (3330B) FREQ
 SWEEP TIME/STEP 3000 msec
 SWEEP STEPS 10
 SWEEP direction UP
 LEVEL (3330A Std and all options) .. full cw
 AMPL (3330B Std and all options)+ 10.00 dBm
 LEVELING (3330B) OFF

c. Press START SINGLE. Record the dc voltmeter indications for each sweep step (0 through 10).

d. The dc voltmeter indications should be within the tolerances shown in Table 5-5.

e. Calculate the linearity as follows:

Using the formula $y = m x + b$, where

y = desired voltage at any sweep step between 0 and 10.

m = slope of straight line between the recorded dc voltmeter indications on the 0 sweep step and the 10 sweep step.

x = sweep step y is being calculated for.

b = recorded dc voltmeter indication on the 0 sweep step.

(1) Determine m by using the recorded dc voltmeter indications on the 0 sweep step and the 10 sweep step as follows:

$$\frac{\text{recorded voltage at 10 sweep step} - \text{recorded voltage at 0 sweep step}}{10}$$

(2) Substitute the voltage calculated in Step e (1) for m in the formula and the recorded dc voltmeter indication on the 0 sweep step for b in the formula.

(3) Calculate y for each sweep step between 0 and 10 substituting that sweep step number for x in the formula each time.

(4) The dc voltmeter indication recorded (Step c) for each sweep step should equal the y calculated in Step e (3) for the corresponding sweep step ± 10 mV ($y - 10$ mVdc \leq voltage recorded $\leq y + 10$ mVdc).

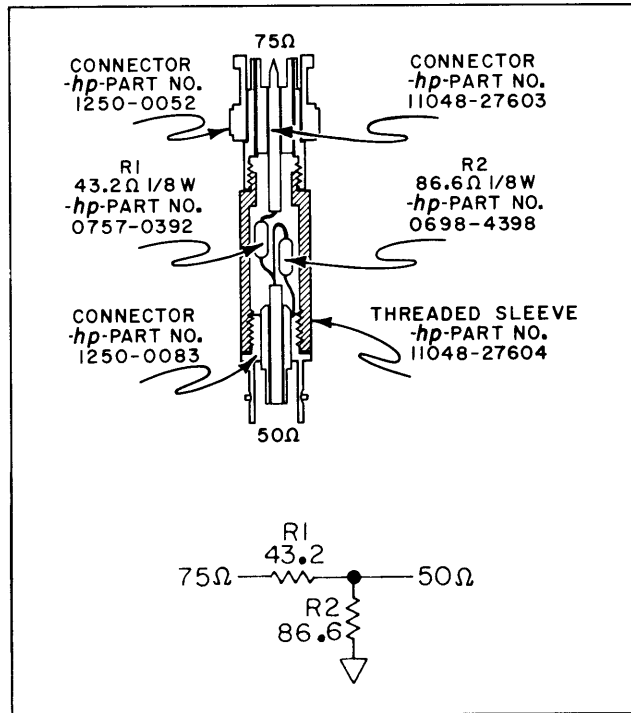

Figure 5-7. 75 Ohm to 50 Ohm Adapter.

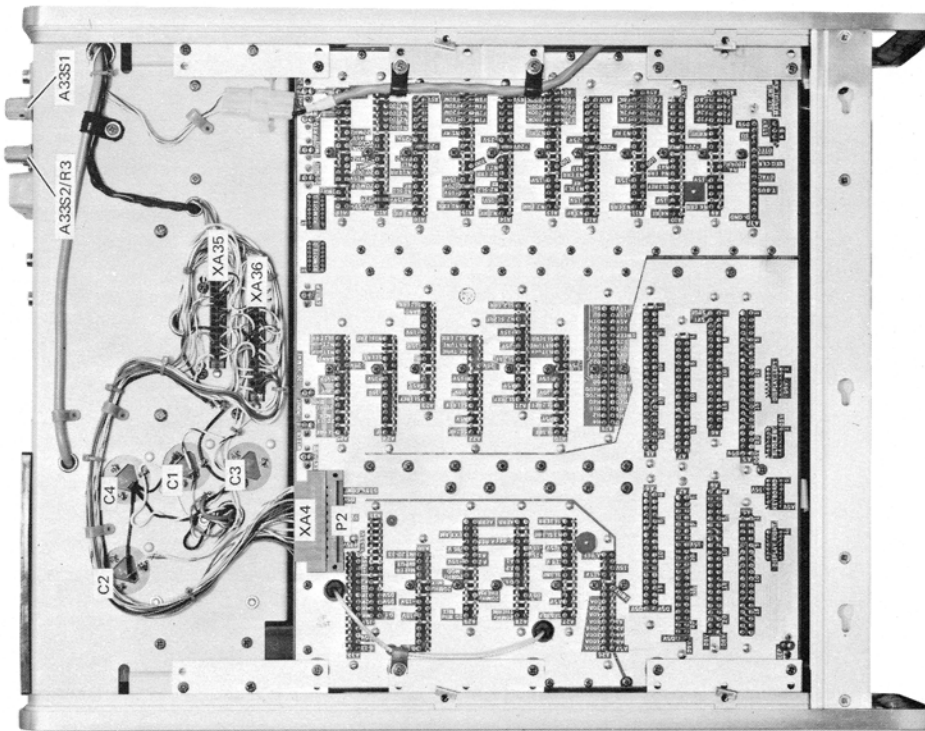
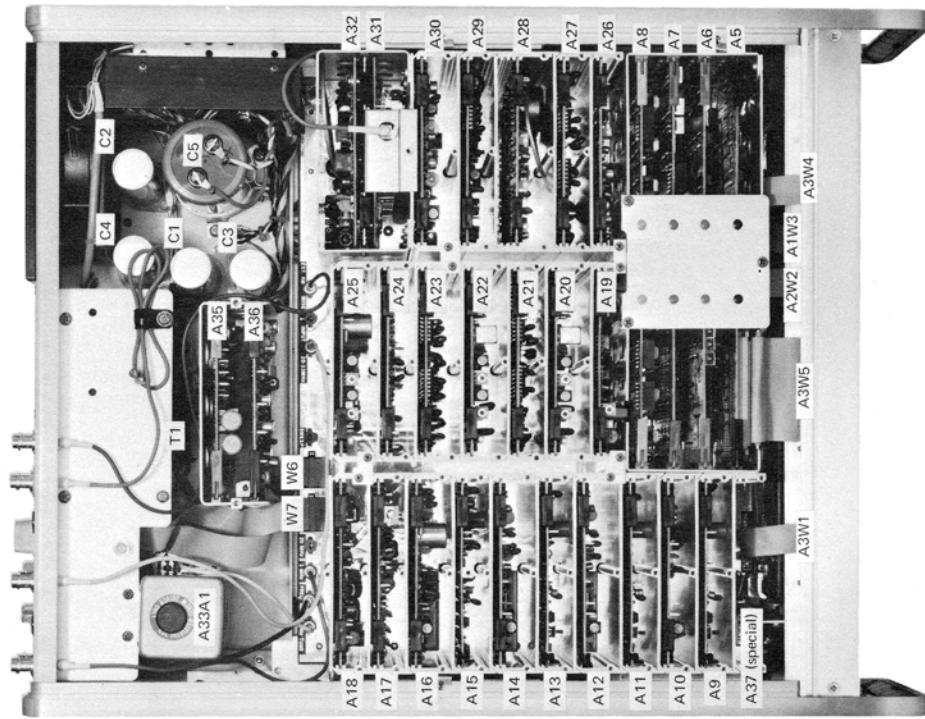

Figure 5-8. Top and Bottom View.

ADJUSTMENT PROCEDURES

5-25. INTRODUCTION.

5-26. The following is a complete adjustment procedure for the 3330A/B. This procedure should be performed only if the 3330A/B has failed the performance checks. If proper performance cannot be achieved after the adjustment procedures have been performed, refer to the troubleshooting procedures in Section VII.

5-27. Power Supply.

5-28. This adjustment procedure sets the + 30 Vdc supply and the - 20 Vdc supply and checks the voltages of the - 30 Vdc, + 29 Vdc, + 20 Vdc, + 15 Vdc, - 15 Vdc, analog + 5 Vdc, and digital + 5 Vdc supplies.

- a. Connect a dc voltmeter between A35TP2 and ground.
- b. Adjust A35R21 (+ 30 V ADJ) for + 29.9 Vdc to + 30.1 Vdc.
- c. Connect the dc voltmeter between A35TP4 and ground.
- d. Adjust A35R42 (- 20 V ADJ) for - 19.99 Vdc to - 20.01 Vdc.
- e. Connect the dc voltmeter to the following test points and insure the voltages are within the limits shown:

A35TP1	+ 28.5 Vdc to + 29.5 Vdc
A35TP3	- 29.4 Vdc to - 30.6 Vdc
A35TP5	+ 20 Vdc to + 22 Vdc
A36TP1	+ 14.7 Vdc to + 15.3 Vdc
A36TP2	- 14.7 Vdc to - 15.3 Vdc
A36TP3	+ 5 Vdc to + 5.25 Vdc
A36TP4	+ 5 Vdc to + 5.25 Vdc

5-29. Reference Oscillator.

5-30. This adjustment procedure sets the 20 MHz reference oscillator frequency and the 5 MHz reference oscillator.

- a. Connect a counter to the 1 MHz OUT on the 3330A/B rear panel.
- b. Set the REF OSC switch (rear panel) to EXT.



Use a non-conducting tool to adjust A17C4. A metal tool may short the + 15 V supply and destroy the fuse, A17F1.

- c. Adjust A17C4 (20 MHz ADJ) for a frequency indication on the counter of 999,999 Hz to 1,000,001 Hz.
- d. Set the REF OSC switch to INT.

- e. Adjust the 5 MHz oscillator coarse frequency adjustment (top of oscillator can) for a frequency indication on the counter of 1,000,000 Hz.

5-31. Sweep.

5-32. This adjustment procedure sets the sweep output voltage. Specifications are ± 0.2% of full-scale (10 Vdc).

- a. Connect a dc voltmeter to the 3330A/B front panel SWEEP OUTPUT.
- b. Program the 3330A/B as follows:

FREQ	0 Hz
FREQ STEP	0 Hz
SWEEP modeFREQ
- c. Set the SWEEP direction switch to the UP position. Press FIRST POINT key.
- d. Adjust A19R21 (ZERO) for - 20 mVdc to + 20 mVdc indication on the dc voltmeter.
- e. Set the SWEEP direction switch to the DOWN position. Press FIRST POINT key.

- f. Adjust A19R23 (GAIN) for + 10.02 Vdc to + 9.98 Vdc indication on the dc voltmeter.

- g. Verify adjustments and repeat if necessary.

5-33. ÷ N Loop

5-34. This adjustment procedure sets the frequency of the ÷ N loop VTOs by monitoring the amount of error signals applied to the VTOs.

- a. Connect the 3330A/B SWEEP OUTPUT to the HORIZONTAL EXT INPUT of an oscilloscope. Connect the vertical input of the oscilloscope to A10TP7(ERR).

- b. Program the 3330A/B as follows:

FREQ	5,050,505.0 Hz
FREQ STEP	101,010.1 Hz
SWEEP mode (3330B)FREQ
SWEEP direction	UP
SWEEP STEPS	100
SWEEP TIME/STEP	1 msec

Press START CONT

- c. Ground the input terminal of the oscilloscope and adjust the vertical position control to position the display at center. Set the oscilloscope vertical gain to 0.5 V/cm and the input terminal to dc. Set the HORIZONTAL DISPLAY to EXT CAL.

d. Adjust A10R17 for 0 Vdc \pm 1.5 Vdc over entire display.

NOTE

The dot pattern indicates the loop is locking up at each frequency step. If any of the dots are replaced by a solid vertical trace, the loop is not locking on that frequency step. A slight vertical trace with a dot in the center may be noticeable. In this case, the loop is still locking up. Refer to the troubleshooting procedures in Section VII if the loop is not locking up.

e. Repeat Step d for the following test points and adjustments.

Test Point	Adjustment
A12TP10	A12R8
A14TP10	A14R8

f. Program the 3330A/B as follows:

```
FREQ .....6.5 MHz
FREQ STEP .....130 kHz
SWEEP mode (3330B) .....FREQ
SWEEP direction ..... UP
SWEEP STEPS .....100
SWEEP TIME/STEP .....1 msec
Press START CONT
```

g. Repeat Step d for the following test point and adjustments:

Test Point	Adjustment
A16TP11	A16R11 A16L1

5-35. SL Loop.

5-36. This adjustment procedure sets the frequency of the SL loop VTOs by monitoring the error signals applied to the VTOs.

a. Place A20 (SL3 VTO) on an extender board.

b., Connect the 3330A/B SWEEP OUTPUT to the HORIZONTAL EXT INPUT of an oscilloscope. Connect the vertical input of the oscilloscope to A20TP3 (ERR).

c. Program the 3330A/B as follows:

```
FREQ ..... 5,050,505.0 Hz
FREQ STEP .....101,010.1 Hz
SWEEP mode .....FREQ
SWEEP direction ..... UP
SWEEP STEPS .....100
SWEEP TIME/STEP .....1 msec
Press START CONT
```

d. Ground the input terminal of the oscilloscope and adjust the vertical position control to position the display

2.5 centimeters below the center line. Set the vertical gain for 1 V/cm and the input terminal to dc. Set the HORIZONTAL DISPLAY to EXT CAL.

e. Adjust A20R15 (GAIN) and A20L3 so the center portion of the oscilloscope display is +2.5 Vdc \pm 1 Vdc. (Step f and g interact with this adjustment.)

NOTE

The dot pattern indicates the loop is locking up at each frequency step. If any of the dots are replaced by a solid vertical trace, the loop is not locking on that frequency step. A slight vertical trace with a dot in the center may be noticeable. In this case, the loop is still locking up. Refer to the troubleshooting procedures in Section VII if the loop is not locking up.

f. Adjust A20R6 (LO BREAK) and A20R8 (LO SLOPE) so the left hand portion of the oscilloscope display is +2.5 Vdc \pm 1 Vdc.

g. Adjust A20R2 (HI BREAK) and A20R4 (HI SLOPE) so the right hand portion of the oscilloscope display is +2.5 Vdc \pm 1 Vdc.

h. Remove the extender board and place A20 (SL3 VTO) in instrument.

i. Repeat Steps b through g until the entire oscilloscope display is +2.5 Vdc \pm 1 Vdc (in Step e delete the adjustment of A20L3).

j. Repeat Steps a through i for the A22 (SL2VTO) assembly.

k. Program the 3330A/B as follows:

```
FREQ .....6.5 MHz
FREQ STEP .....130 kHz
SWEEP mode (3330B) .....FREQ
SWEEP direction ..... UP
SWEEP STEPS .....100
SWEEP TIME/STEP .....1 msec
Press START CONT
```

l. Repeat Steps a through i for the A25 (SL1 VTO) assembly.

5-37. Amplitude Reference (3330B).

5-38. This adjustment procedure sets the reference dc level from the Amplitude Reference assembly.

a. Connect a dc voltmeter to A26TP25.

b. Program the 3330B AMPL for +13.44 dBm (+11.68 Option 001, +26.99 Option 005). Adjust A26R17 (10 V ADJ) for 10.000 Vdc \pm 0.002 Vdc indication on the dc voltmeter. Use an amplitude step of 9.99 dB and Amplitude \uparrow and Amplitude \downarrow for shifting between amplitudes in Steps b and c.

c. Program the 3330B AMPL for +3.45 dBm (+ 1.69 Option 001, +17.00 Option 005). Adjust A26R22 (3.1659 V ADJ) for 3.1659 Vdc ± 0.0006 Vdc indication on the dc voltmeter.

5-39. Output Mixer Balance.

5-40. This adjustment procedure sets the carrier balance and ac balance for minimum from the Output Mixer.

- a. Connect an ac voltmeter to A30TP1.
- b. Program the 3330A/B FREQ to 100 Hz. Adjust A30R7 (AC BAL) for a null indication on the ac voltmeter (<100 mVac).
- c. Place A30 on an extender board. Remove the output cable (violet) from A32P1 and connect it to A30P1. Connect a spectrum analyzer to the 3330A/B output. Raise A31 and A32 out of the socket.
- d. Program the 3330A/B FREQ to 0.5 MHz. Adjust A30R18 (CARRIER BAL) for a minimum amplitude display of the 20.5 MHz signal on the spectrum analyzer.
- e. Replace the output cable to A32P1. Remove A30 from the extender board and replace into the A30 socket.

5-41. Amplitude.

5-42. This adjustment procedure sets the dc balance of the Amplitude Detector assembly (3330B) and the output amplitude flatness and level (3330A/B).

a. Connect an oscilloscope (without divider probe) through a peak detector and a 50 ohm load (75 ohm load, Option 001), to the 3330A/B output. Connect the oscilloscope HORIZONTAL EXT INPUT to the 3330A/B SWEEP OUTPUT. Set the HORIZONTAL DISPLAY on the oscilloscope to EXT CAL. Set the oscilloscope vertical input to ac coupled, .01 VOLTS/DIV (.05 VOLTS/DIV Option 005).

b. Program the 3330A/B as follows:

```
FREQ .....6.5 MHz
FREQ STEP .....130 kHz
SWEEP mode (3330B).....FREQ
SWEEP direction ..... UP
SWEEP STEPS .....100
SWEEP TIME/STEP .....1 msec
LEVEL (3330A Std and all options) .. full cw
AMPL (3330B Std) ..... +13.44 dBm
      (Option 001) ..... +11.68 dBm
      (Option 005) ..... +26.99 dBm
LEVELING (3330B) ..... OFF
Press START CONT
```

c. Adjust A30C18, A30C19, and A30R51 for <3 divisions p-p on the oscilloscope display.

NOTE

The frequency response of the test equipment is limited to 100 kHz on the lower end. This results in transient on the left end (<2 cm) of the oscilloscope display. These transients should be ignored.

3330A:

- d. Place the A29 Amplitude Modulator on an extender board. Connect a dc voltmeter to A29TP4.
- e. Set the 3330A LEVEL full cw and adjust A29R37 for 10.0 Vdc ± 0.05 Vdc indication on the dc voltmeter.
- f. Disconnect the dc voltmeter from A29TP4 and connect an oscilloscope (ac coupled) to A29TP1.
- g. Adjust A29R25 for 5.6 V p-p ± 0.28 V p-p on the oscilloscope display.
- h. Disconnect the oscilloscope and peak detector from A29TP1. Connect an ac voltmeter through a 50 ohm load (75 ohm load, Option 001) to the 3330A output.
- i. Program the 3330A as follows:

```
FREQ .....10 kHz
LEVEL ..... full cw
```

- j. Adjust A30R35 for an ac voltmeter indication of 1.00 Vac ± 0.02 Vac (Std and Option 001; 5.00 Vac ± 0.10 Vac, Option 005).
- k. Connect a dc voltmeter to the 3330A output. Adjust A30R40 for 0 Vdc ± 0.002 Vdc (Std and Option 001; +.04 Vdc ± 0.010 Vdc Option 005) indication on the dc voltmeter.

3330B:

- d. Remove the A29 Amplitude Modulator assembly and disconnect the 0-13 MHz cable (clear) from the A32 Output Amplifier assembly. Short A28 TP2 to ground with a jumper cable.
- e. Connect a 5 ohm resistor (two 10 ohm resistors in parallel) between A28TP1 and ground with jumper cables. Connect the Channel A input of an oscilloscope across the 5 ohm resistor.
- f. Set the oscilloscope vertical input to dc coupled, .1 VOLTS/DIV. Adjust the oscilloscope display for a convenient reference (no divider probe).
- g. Adjust A28R12 (BALANCE) until there is a noticeable (approximately 1.5 cm) dc level shift in either direction on the oscilloscope display, then readjust A28R12 in the opposite direction until the dc level on the oscilloscope display is on the threshold of shifting back.

h. Remove the 5 ohm resistor and all jumper cables. Replace A29 and reconnect the clear cable to A32. Connect a dc voltmeter to the 3330B output.

i. Program the 3330B FREQ to 10 kHz and AMPL to +13.44 dBm (+11.68 Option 001, +26.99 Option 005). Adjust A30R40 (OFFSET ADJ) for a 0 Vdc \pm 0.002 Vdc (Std and Option 005; 0 Vdc \pm 0.010 Vdc, Option 005) indication on the dc voltmeter.

j. Connect an ac voltmeter through a 50 ohm load (75 ohm load, Option 001) to the 3330B output.

k. Program the 3330B as follows:

```
FREQ ..... 10 kHz
AMPL (Std) ..... +13.44 dBm
  (Option 001) ..... +11.68 dBm
  (Option 005) ..... +26.99 dBm
LEVELING .....FAST (>1 kHz)
AMPL STEP ..... 9.99 dBm
```

l. Adjust A28R30 (GAIN) for 1.05071 Vac \pm 0.001 Vac (Std and Option 001; 5.0000 Vac \pm 0.005 Vac Option 005) indication on the ac voltmeter. If A28R30 does not have enough range, remove A28A1 (thermopile), rotate it 180°, and replace it back on the A28 assembly. Repeat adjustment of A28R30.

m. Program the 3330B AMPL for +3.45 dBm (+1.69 Option 001, +17.00 Option 005). You can obtain this amplitude by pressing AMPL \downarrow . Adjust A28R33 (OFFSET)

for 0.33264 Vac \pm 0.002 Vac (Std and Option 001; 1.5830 Vac \pm 0.0016 Vac, Option 005) indication on the ac voltmeter.

n. Repeat Steps l and m until correct output is obtained at both levels.

o. Program the 3330B AMPL for +13.44 dBm (+11.68 Option 001, +26.99 Option 005) and LEVELING to OFF. You can obtain this amplitude by pressing AMPL \uparrow . Adjust A30R35 for 1.05 Vac \pm 0.02 Vac (Std and Option 001; 5.00 Vac \pm 0.1 Vac, Option 005).

p. Connect a dc voltmeter to A29TP2.

q. Program the 3330B as follows:

```
FREQ ..... 10 kHz
AMPL (Std) ..... +13.44 dBm
  (Option 001) ..... +11.68 dBm
  (Option 005) ..... +26.99 dBm
AMPL STEP ..... 9.99 dBm
TIME/STEP ..... 3000 msec
LEVELING ..... OFF
```

r. Set A29TP2 for 2 V with A29R33. Note dc voltmeter indication. Press AMPL \downarrow . The dc voltmeter indication should not vary more than 0.2 Vdc. If the dc voltmeter varies more than 0.2 Vdc, adjust A29R33 slightly and press AMPL \downarrow .

s. Repeat Step r until dc voltmeter varies $<$ 0.2 Vdc.

PERFORMANCE CHECK TEST CARD

Hewlett-Packard Model 3330A/B
Automatic Synthesizer

Test Performed By _____

Serial No. _____

Date _____

Harmonic Distortion:

1 kHz	2nd	_____	> - 60 dB
	3rd	_____	> - 60 dB
	4th	_____	> - 60 dB
90 kHz	2nd	_____	> - 60 dB
	3rd	_____	> - 60 dB
	4th	_____	> - 60 dB
110 kHz	2nd	_____	> - 50 dB
	3rd	_____	> - 50 dB
	4th	_____	> - 50 dB
600 kHz	2nd	_____	> - 50 dB
	3rd	_____	> - 50 dB
	4th	_____	> - 50 dB
2 MHz	2nd	_____	> - 40 dB
	3rd	_____	> - 40 dB
	4th	_____	> - 40 dB
13 MHz	2nd	_____	> - 40 dB
	3rd	_____	> - 40 dB
	4th	_____	> - 40 dB

Signal to Phase Noise: _____ > - 50 dB

Spurious:

3330A	_____	> - 70 dB
3330B	_____	> - 70 dB or - 110 dB

Amplitude Accuracy:

3330A			
50 ohm load	0.9 Vrms	_____	1.1 Vrms
Open circuit	1.8 Vrms	_____	2.2 Vrms
3330B			
50 ohm load	1.0447 Vrms	_____	1.0553 Vrms
Open circuit	2.0895 Vrms	_____	2.1105 Vrms

Frequency Response (+ 13 dBm):

3330A	6.3 mVdc	_____	7.7 mVdc
3330B	6.93 mVdc	_____	7.07 mVdc

3330B Adjusted Errors (Para. 5-18(e)): C in the formula $A = B + C - D$

100 kHz	1 MHz	2.5 MHz	5 MHz	7.5 MHz	10 MHz	13 MHz

Attenuator Accuracy (3330B) (Para. 5-20(d)): D in the formula $A = B + C - D$

Standard	Option 001	Option 005	
+ 3.44 dBm	+ 1.68 dBm	+ 15.20 dBm	0.998 Vdc _____ 1.002 Vdc
- 6.56 dBm	- 8.32 dBm	+ 5.00 dBm	0.996 Vdc _____ 1.004 Vdc
- 16.56 dBm	- 18.32 dBm	- 5.00 dBm	0.994 Vdc _____ 1.006 Vdc
- 26.56 dBm	- 28.32 dBm	- 15.00 dBm	0.992 Vdc _____ 1.008 Vdc
- 36.56 dBm	- 38.32 dBm	- 25.00 dBm	0.990 Vdc _____ 1.010 Vdc
- 46.56 dBm	- 48.32 dBm	- 35.00 dBm	0.988 Vdc _____ 1.012 Vdc
- 56.56 dBm	- 58.32 dBm	- 45.00 dBm	0.986 Vdc _____ 1.014 Vdc
- 66.56 dBm	- 68.32 dBm	- 55.00 dBm	0.984 Vdc _____ 1.016 Vdc
- 76.56 dBm	- 78.32 dBm	- 65.00 dBm	0.982 Vdc _____ 1.018 Vdc

Attenuator Frequency Response 3330B (Option 005):

Recorded Readings (Para. 5-22(d)): B in the formula $A = B + C - D$

	100 kHz	1 MHz	2.5 MHz	5 MHz	7.5 MHz	10 MHz	13 MHz
+ 6.99 dBm	_____	_____	_____	_____	_____	_____	_____
- 3.01 dBm	_____	_____	_____	_____	_____	_____	_____
- 13.01 dBm	_____	_____	_____	_____	_____	_____	_____
- 23.01 dBm	_____	_____	_____	_____	_____	_____	_____
- 33.01 dBm	_____	_____	_____	_____	_____	_____	_____
- 43.01 dBm	_____	_____	_____	_____	_____	_____	_____
- 53.01 dBm	_____	_____	_____	_____	_____	_____	_____
- 63.01 dBm	_____	_____	_____	_____	_____	_____	_____
- 73.01 dBm	_____	_____	_____	_____	_____	_____	_____

Calculated Errors (Para. 5-22(h)): A in the formula $A = B + C - D$

	100 kHz	1 MHz	2.5 MHz	5 MHz	7.5 MHz	10 MHz	13 MHz	Tolerance
+ 6.99 dBm	_____	_____	_____	_____	_____	_____	_____	± 5 mV
- 3.01 dBm	_____	_____	_____	_____	_____	_____	_____	± 5 mV
- 13.01 dBm	_____	_____	_____	_____	_____	_____	_____	± 12 mV
- 23.01 dBm	_____	_____	_____	_____	_____	_____	_____	± 12 mV
- 33.01 dBm	_____	_____	_____	_____	_____	_____	_____	± 30 mV
- 43.01 dBm	_____	_____	_____	_____	_____	_____	_____	± 30 mV
- 53.01 dBm	_____	_____	_____	_____	_____	_____	_____	± 30 mV
- 63.01 dBm	_____	_____	_____	_____	_____	_____	_____	± 55 mV
- 73.01 dBm	_____	_____	_____	_____	_____	_____	_____	± 55 mV

Sweep Output:

Accuracy

Sweep Step

0	-0.02 Vdc	_____	0.02 Vdc
1	0.98 Vdc	_____	1.02 Vdc
2	1.98 Vdc	_____	2.02 Vdc
3	2.98 Vdc	_____	3.02 Vdc
4	3.98 Vdc	_____	4.02 Vdc
5	4.98 Vdc	_____	5.02 Vdc
6	5.98 Vdc	_____	6.02 Vdc
7	6.98 Vdc	_____	7.02 Vdc
8	7.98 Vdc	_____	8.02 Vdc
9	8.98 Vdc	_____	9.02 Vdc
10	9.98 Vdc	_____	10.02 Vdc

Linearity

m Calculated

y Calculated

Sweep Step

0	_____
1	_____
2	_____
3	_____
4	_____
5	_____
6	_____
7	_____
8	_____
9	_____
10	_____

Specification

Sweep Step

0	y - 10 mV	_____	y + 10 mV
1	y - 10 mV	_____	y + 10 mV
2	y - 10 mV	_____	y + 10 mV
3	y - 10 mV	_____	y + 10 mV
4	y - 10 mV	_____	y + 10 mV
5	y - 10 mV	_____	y + 10 mV
6	y - 10 mV	_____	y + 10 mV
7	y - 10 mV	_____	y + 10 mV
8	y - 10 mV	_____	y + 10 mV
9	y - 10 mV	_____	y + 10 mV
10	y - 10 mV	_____	y + 10 mV

SECTION VI REPLACEABLE PARTS

6-1. INTRODUCTION.

6-2. This section contains information for ordering replacement parts. Table 6-1 lists parts in alphabetic order of their reference designators and indicates the -hp- part number of each part, with any applicable notes, and provides the following:

- a. Total quantity used in the instrument (TQ column). The total quantity of a part is given the first time the part number appears.
- b. Description of the part. See list of abbreviations below.
- c. Typical manufacturer of the part in a five-digit code. See Appendix A for a list of manufacturers.
- d. Manufacturer's part number.

6-3. Miscellaneous parts are listed at the end of Table 6-1.

6-4. ORDERING INFORMATION.

6-5. To obtain replacement parts, address order or inquiry to your local Hewlett-Packard Field Office. See Appendix B for a list of office locations. Identify parts by their Hewlett-Packard part numbers. Rebuilt boards can be purchased at a reduced price on an exchange basis. For more information contact your local Hewlett-Packard Field Office.

6-6. NON-LISTED PARTS.

6-7. To obtain a part that is not listed, include:

- a. Instrument model number.
- b. Instrument serial number.
- c. Description of the part.
- d. Function and location of the part.

ABBREVIATIONS		
Ag silver	Hz hertz (cycle(s) per second)	NPO negative positive zero (zero temperature coefficient)
Al aluminum	ID inside diameter	ns nanosecond(s) = 10 ⁻⁹ seconds
A ampere(s)	imp impregnated	nsr not separately replaceable
Au gold	incd incandescent	
C capacitor	ins insulation(led)	Ω ohm(s)
cer ceramic	kΩ kilohm(s) = 10 ³ ohms	obd order by description
coef coefficient	kHz kilohertz = 10 ³ hertz	OD outside diameter
com common	L inductor	p peak
comp composition	lin linear taper	pA picoampere(s)
conn connection	log logarithmic taper	pc printed circuit
dep deposited	mA milliampere(s) = 10 ⁻³ amperes	pF picofarad(s) 10 ⁻¹² farads
DPDT double-pole double-throw	MHz megahertz = 10 ⁶ hertz	piv peak inverse voltage
DPST double-pole single-throw	MΩ megohm(s) = 10 ⁶ ohms	p/o part of
elect electrolytic	met film metal film	pos position(s)
encap encapsulated	mfr manufacturer	pot polystyrene
F farad(s)	ms millisecond	pot potentiometer
FET field effect transistor	mtg mounting	p-p peak-to-peak
fxd fixed	mV millivolt(s) = 10 ⁻³ volts	ppm parts per million
GaAs gallium arsenide	μF microfarad(s)	prec precision (temperature coefficient, long term stability and/or tolerance)
GHz gigahertz = 10 ⁹ hertz	μS microsecond(s)	R resistor
gd guard(led)	μV microvolt(s) = 10 ⁻⁶ volts	Rh rhodium
Ge germanium	my Mylar®	rms root-mean-square
gnd ground(led)	nA nanoampere(s) = 10 ⁻⁹ amperes	rot rotary
H henry(ies)	NC normally closed	Se selenium
Hg mercury	Ne neon	sect section(s)
	NO normally open	Si silicon

DECIMAL MULTIPLIERS					
Prefix	Symbols	Multiplier	Prefix	Symbols	Multiplier
tera	T	10 ¹²	centi	c	10 ⁻²
giga	G	10 ⁹	milli	m	10 ⁻³
mega	M or Meg	10 ⁶	micro	μ	10 ⁻⁶
kilo	K or k	10 ³	nano	n	10 ⁻⁹
hecto	h	10 ²	pico	p	10 ⁻¹²
deka	da	10	femto	f	10 ⁻¹⁵
deci	d	10 ⁻¹	atto	a	10 ⁻¹⁸

DESIGNATORS			
A assembly	FL filter	Q transistor	TS terminal strip
B motor	HR heater	QCR transistor-diode	U microcircuit
BT battery	IC integrated circuit	R resistor	V vacuum tube, neon bulb, photocell, etc.
C capacitor	J jack	RT thermistor	W cable
CR diode	K relay	S switch	X socket
DL delay line	L inductor	T transformer	XDS lampholder
DS lamp	M meter	TB terminal board	XF fuseholder
E misc electronic part	MP mechanical part	TC thermocouple	Y crystal
F fuse	P plug	TP test point	Z network

STD-B-2734

® Dupont de Nemours

Table 6-1. Replaceable Parts

Reference Designation	HP Part Number	Qty	Description	Mfr Code	Mfr Part Number
A1B Δ14	03330-66580	1	KEYBOARD ASSEMBLY	28480	03330-66580
A1C1	0150-0084		C:FXD 0.1 UF	28480	0150-0084
A1C2	0160-0127		C:FXD 1 UF	28480	0160-0127
A1C3	0160-3847		C:FXD S1 NPN	28480	0160-3847
A1Q1	1854-0071		TSTR:S1 NPN	28480	1854-0071
A1R1 - A1R6	0683-2725		R:FXD 2.7 kΩ	01121	C82725
A17R7, R8	0757-0442		R:FXD 10K	24546	C4-1/8-T0-1002-F
A17R9	0757-0280		R:FXD 1K	24546	C4-1/8-T0-1001-F
A1R10	0698-3228		R:FXD 49.9 kΩ	03888	PME55S
A1R11	0757 0401		R:FXD 1 kΩ	24546	C4-1/8-T0-101-F
A1R12	0757-0411		R:FXD 332 Ω	24546	C4-1/8-T0-332R-F
A1S1 - A1S36	3101-1745	36	SWITCH	28480	3101-1745
A1U1	1820-1418		IC:DIGITAL	01295	SN74LS42N
A1U2	1820-1217		IC:DIGITAL	01295	SN74LS151N
A1U3, U4	1820-1478		IC:DIGITAL	01295	SN74LS93N
A1U5	1820-1197		IC:DIGITAL	01295	SN74LS00N
A1U6	1820-1423		IC:DIGITAL	01295	SN74LS123N
A1W3	03330-61601	1	CABLE	28480	03330-61601
A1MP1	03330-04119	1	4-KEY MOUNTING PLATE, LEFT	28480	03330-04119
A1MP2	03330-04120	1	4-KEY MOUNTING PLATE, RIGHT	28480	03330-04120
A1MP3	03330-04121	1	16-KEY MOUNTING PLATE	28480	03330-04121
A1MP4	03330-04122	1	12-KEY MOUNTING PLATE	28480	03330-04122
SEE PAGE 6-48 FOR KEYS					
A2A (A ONLY)	03330-66568	1	PC ASSY:SLIDE SWITCH BOARD	28480	03330-66568
A2B (B ONLY)	03330-66502	1	PC ASSY: SLIDE SWITCH BOARD (IDENTICAL TO A2A)	28480	03330-66502
A21C1	1820-0077		IC:TTL DUAL D F/F	01295	SN7474N
A2K1	1810-0041	1	R:NETWORK, 8 RES. 2.7K OHM 5%	28480	1810-0041
A2R2	0583-2725	1	R:FXD COMP 2700 OHM 5% 1/4W	01121	C8 2725
A2S1	3101-1704	2	SLIDE SWITCH ASSY	28480	3101-1704
A2S2 (B ONLY)	3101-1704		SLIDE SWITCH ASSY	28480	3101-1704
A2S3	3101-1703	2	SLIDE SWITCH ASSY	28480	3101-1703
A2S4	3101-1703		SLIDE SWITCH ASSY	28480	3101-1703
A2W1			NOT ASSIGNED		
A2W2	03330-61601		CABLE ASSY:FLAT	28480	03330-61601
A3A (A ONLY)	03330-66569	1	PC ASSY:FRONT PANEL	28480	03330-66569
A3C1	0180-0116	4	C:FXD ELECT 6.8 UF 10% 35VDCW	56289	150D685X903532-DYS
A3C2	0180-0116		C:FXD ELECT 6.8 UF 10% 35VDCW	56289	150D685X903532-DYS
A3CR1	1990-0325	57	DIODE:VISIBLE LIGHT EMITTER	28480	1990-0325
A3CR2	1990-0325		DIODE:VISIBLE LIGHT EMITTER	28480	1990-0325
A3CR3	1990-0325		DIODE:VISIBLE LIGHT EMITTER	28480	1990-0325
A3CR4	1990-0325		DIODE:VISIBLE LIGHT EMITTER	28480	1990-0325
A3CR5	1990-0325		DIODE:VISIBLE LIGHT EMITTER	28480	1990-0325
A3CR6	1990-0325		DIODE:VISIBLE LIGHT EMITTER	28480	1990-0325
A3CR7	1990-0325		DIODE:VISIBLE LIGHT EMITTER	28480	1990-0325
A3CR8	1990-0325		DIODE:VISIBLE LIGHT EMITTER	28480	1990-0325
A3CR9	1990-0325		DIODE:VISIBLE LIGHT EMITTER	28480	1990-0325
A3CR10	1990-0325		DIODE:VISIBLE LIGHT EMITTER	28480	1990-0325
A3CR11	1990-0325		DIODE:VISIBLE LIGHT EMITTER	28480	1990-0325
A3CR12	1990-0325		DIODE:VISIBLE LIGHT EMITTER	28480	1990-0325
A3CR13	1990-0325		DIODE:VISIBLE LIGHT EMITTER	28480	1990-0325
A3CR14	1990-0325		DIODE:VISIBLE LIGHT EMITTER	28480	1990-0325
A3CR15			NOT ASSIGNED		
A3CR16	1990-0325		DIODE:VISIBLE LIGHT EMITTER	28480	1990-0325
A3CR17	1990-0325		DIODE:VISIBLE LIGHT EMITTER	28480	1990-0325
A3CR18	1990-0325		DIODE:VISIBLE LIGHT EMITTER	28480	1990-0325
A3CR19			NOT ASSIGNED		
A3CR20	1990-0325		DIODE:VISIBLE LIGHT EMITTER	28480	1990-0325
A3CR21	1990-0325		DIODE:VISIBLE LIGHT EMITTER	28480	1990-0325
A3CR22	1990-0325		DIODE:VISIBLE LIGHT EMITTER	28480	1990-0325
A3CR23	1990-0325		DIODE:VISIBLE LIGHT EMITTER	28480	1990-0325
A3CR24	1990-0325	22	DIODE:VISIBLE LIGHT EMITTER	28480	1990-0325
A3F01			NOTE: IDENTIFY BRIGHTNESS CATEGORY BY LETTER		
A3F02			STAMPED ON BACK OF DISPLAY AND ORDER CORRES-		
A3F03			PONDING PART NUMBER AS FOLLOWS:		
A3F04	1990-0497		NUMERICAL DISPLAY:BRIGHTNESS "A"		
A3F05	1990-0499		NUMERICAL DISPLAY:BRIGHTNESS "B"		
A3F06	1990-0502		NUMERICAL DISPLAY:BRIGHTNESS "C"		
A3F07	1990-0504		NUMERICAL DISPLAY:BRIGHTNESS "D"		
A3F08	1990-0506		NUMERICAL DISPLAY:BRIGHTNESS "E"		
A3F09	1990-0508		NUMERICAL DISPLAY:BRIGHTNESS "F"		
	1990-0510		NUMERICAL DISPLAY:BRIGHTNESS "G"		

See introduction to this section for ordering information

Table 6-1. Replaceable Parts(Cont'd)

Reference Designation	HP Part Number	Qty	Description	Mfr Code	Mfr Part Number
A3J1, J2	1200-0468	2	SOCKET-24 CONTACT	28480	1200 0468
A3J3	1200-0466	1	SOCKET-40 CONTACT	28480	1200-0466
A3K1	0683-1025	41	R:FXD COMP 1000 OHM 5% 1/4W	01121	CB 1025
A3K2			NOT ASSIGNED		
A3K3	0683-8205	18	R:FXD COMP 82 OHM 5% 1/4W	01121	CB 8205
A3K4	0683-8205		R:FXD COMP 82 OHM 5% 1/4W	01121	CB 8205
A3K5	0683-8205		R:FXD COMP 82 OHM 5% 1/4W	01121	CB 8205
A3K6	0683-4305	20	R:FXD COMP 43 OHM 5% .25W	01121	CB 4305
A3K7	0683-4305		R:FXD COMP 43 OHM 5% .25W	01121	CB 4305
A3K8	0683-4305		R:FXD COMP 43 OHM 5% .25W	01121	CB 4305
A3K9	0683-4305		R:FXD COMP 43 OHM 5% .25W	01121	CB 4305
A3K10	0683-8205		R:FXD COMP 82 OHM 5% 1/4W	01121	CB 8205
A3R11	0683-4305		R:FXD COMP 43 OHM 5% .25W	01121	CB 4305
A3R13	0683-8205		R:FXD COMP 82 OHM 5% 1/4W	01121	CB 8205
A3R14	0683-4305		R:FXD COMP 43 OHM 5% .25W	01121	CB 4305
A3R15			NOT ASSIGNED		
A3R16	0683-4305		R:FXD COMP 43 OHM 5% .25W	01121	CB 4305
A3R17	0683-4305		R:FXD COMP 43 OHM 5% .25W	01121	CB 4305
A3R18	0683-8205		R:FXD COMP 82 OHM 5% 1/4W	01121	CB 8205
A3W1	03330-61603	2	CABLE ASSY:FLAT	28480	03330-61603
A3W2			NOT ASSIGNED		
A3W3			NOT ASSIGNED		
A3W4	03330-61602	2	CABLE ASSY:FLAT	28480	03330-61602
A3W5	03330-61604	2	CABLE ASSY:FLAT	28480	03330-61604
A3B (B ONLY)	03330-66503	1	PC ASSY:DISPLAY BOARD	28480	03330-66503
A3 AD1					
A3 AD2					
A3 AD3					
A3 AD4					
A3 AD5	1990-0399	1	INDICATOR PDL	28480	1990-0399
A3 C1	0180-0116		C:FXD ELECT 6.8 UF 10% 35VDCW	56289	1500685X903582-DYS
A3 C2	0180-0116		C:FXD ELECT 6.8 UF 10% 35VDCW	56289	1500685X903582-DYS
A3 CR1 THRU					
A3 CR35	1990-0325		DIODE:VISIRUF LIGHT EMITTER	28480	1990-0325
A3 FD1					
A3 FD2					
A3 FD3					
A3 FD4					
A3 FD5					
A3 FD6					
A3 FD7					
A3 FD8					
A3 FD9					
A3J1, J2	1200-0468	1	SOCKET-24 CONTACT	28480	1200-0468
A3J3	1200-0466		SOCKET-40 CONTACT	28480	1200-0466
A3J4	1200-0467		SOCKET-36 CONTACT	28480	1200-0467
A3R1, R2	0683-1025		RES COMP 1000 OHM 5% 1/4W	28480	0683-1025
A3 R3, R4	0683-8205		RES COMP 82 OHM 5% 1/4W	01121	CB 8205
A3 K5	0683-8205		RES COMP 82 OHM 5% 1/4W	01121	CB 8205
A3 R6	0683-4305		RES COMP 43 OHM 5% .25W	01121	CB 4305
A3 K7	0683-4305		RES COMP 43 OHM 5% .25W	01121	CB 4305
A3 R8	0683-4305		RES COMP 43 OHM 5% .25W	01121	CB 4305
A3 K9	0683-4305		RES COMP 43 OHM 5% .25W	01121	CB 4305
A3 R10	0683-8205		RES COMP 82 OHM 5% 1/4W	01121	CB 8205
A3 K11	0683-4305		RES COMP 43 OHM 5% .25W	01121	CB 4305
A3 K12	0683-8205		RES COMP 82 OHM 5% 1/4W	01121	CB 8205
A3 R13	0683-8205		RES COMP 82 OHM 5% 1/4W	01121	CB 8205
A3 K14	0683-4305		RES COMP 43 OHM 5% .25W	01121	CB 4305
A3 K15	0683-8205		RES COMP 82 OHM 5% 1/4W	01121	CB 8205
A3 R16	0683-4305		RES COMP 43 OHM 5% .25W	01121	CB 4305
A3 R17	0683-4305		RES COMP 43 OHM 5% .25W	01121	CB 4305
A3 K18	0683-8205		RES COMP 82 OHM 5% 1/4W	01121	CB 8205
A3 R19	0683-8205		RES COMP 82 OHM 5% 1/4W	01121	CB 8205
A3 K20	0683-8205		RES COMP 82 OHM 5% 1/4W	01121	CB 8205
A3 R21	0683-8205		RES COMP 82 OHM 5% 1/4W	01121	CB 8205
A3 R22	0683-4305		RES COMP 43 OHM 5% .25W	01121	CB 4305
A3 R23	0683-4305		RES COMP 43 OHM 5% .25W	01121	CB 4305
A3 K24	0683-4305		R:FXD COMP 43 OHM 5% .25W	01121	CB 4305
A3 R25	0683-4305		R:FXD COMP 43 OHM 5% .25W	01121	CB 4305
A3 W1	03330-61603		CABLE ASSY:FLAT	28480	03330-61603
A3 W2			NOT ASSIGNED		
A3 W3			NOT ASSIGNED		
A3 W4	03330-61602		CABLE ASSY:FLAT	28480	03330-61602
A3 W5	03330-61604		CABLE ASSY:FLAT	28480	03330-61604
A4	03330-66504	1	PC ASSY:MOTHER BOARD	28480	03330-66504
A4J1	1200-0424	5	SOCKET:IC BLK 14 CONTACT	23880	CSA2900-14B
A4J2	1200-0424		SOCKET:IC BLK 14 CONTACT	23880	CSA2900-14B

See introduction to this section for ordering information

1SEE NOTE AND PART NUMBERS LISTED FOR A3FD1 THRU A3FD9, PAGE 6-2.

Table 6-1. Replaceable Parts(Cont'd)

Reference Designation	HP Part Number	Qty	Description	Mfr Code	Mfr Part Number
A4J3	1200-0424	14	SOCKET:IC BLK 14 CONTACT	23880	CSA2900-148
A4J4	1200-0424		SOCKET:IC BLK 14 CONTACT	23880	CSA2900-148
A4J5	1251-2969		CONNECTOR:PHONE, SINGLE JACK	27264	15-24-0501
A4J6	1251-2969		CONNECTOR:PHONE, SINGLE JACK	27264	15-24-0501
A4J7	1251-2969		CONNECTOR:PHONE, SINGLE JACK	27264	15-24-0501
A4J8	1251-2969		CONNECTOR:PHONE, SINGLE JACK	27264	15-24-0501
A4J9	1251-2969		CONNECTOR:PHONE, SINGLE JACK	27264	15-24-0501
A4J10	1200-0424	1	SOCKET:IC BLK 14 CONTACT	23880	CSA2900-148
A4J11	1200-0423		SOCKET:IC BLK 16 CONTACT	23880	CSA2900-168
A4J12	1251-2969		CONNECTOR:PHONE, SINGLE JACK	27264	15-24-0501
A4J13	1251-2969		CONNECTOR:PHONE, SINGLE JACK	27264	15-24-0501
A4J14	1251-2969	4	CONNECTOR:PHONE, SINGLE JACK	27264	15-24-0501
A4J15	1251-2969		CONNECTOR:PHONE, SINGLE JACK	27264	15-24-0501
A4P1	1251-3305		CONNECTOR:R&P	27264	09-56-1041-(A-2183-4A)
A4P2	1251-3144	1	CONNECTOR:R&P, 17 MALE CONTACT	00779	3-582152-1
A4XA1		4	NOT ASSIGNED		
A4XA2			NOT ASSIGNED		
A4XA3			NOT ASSIGNED		
A4XA4			NOT ASSIGNED		
A4XA5	1251-1887	15	CONNECTOR:PC 44 CONTACTS(2 X 22)	71785	252-22-30-340
A4XA5	1251-2134		CONNECTOR:PC (2X18)36 CONTACTS	71785	252-18-30-340
A4XA6	1251-2134		CONNECTOR:PC (2X18)36 CONTACTS	71785	252-18-30-340
A4XA6	1251-1887		CONNECTOR:PC 44 CONTACTS(2 X 22)	71785	252-22-30-340
A4XA7	1251-2134		CONNECTOR:PC (2X18)36 CONTACTS	71785	252-18-30-340
A4XA7	1251-2134		CONNECTOR:PC (2X18)36 CONTACTS	71785	252-18-30-340
A4XA7	1251-1887		CONNECTOR:PC 44 CONTACTS(2 X 22)	71785	252-22-30-340
A4XA8	1251-1887	13	CONNECTOR:PC 44 CONTACTS(2 X 22)	71785	252-22-30-340
A4XA9	1251-2134		CONNECTOR:PC (2X18)36 CONTACTS	71785	252-18-30-340
A4XA9	1251-2134		CONNECTOR:PC (2X18)36 CONTACTS	71785	252-18-30-340
A4XA10	1251-2134		CONNECTOR:PC (2X18)36 CONTACTS	71785	252-18-30-340
A4XA11	1251-2134		CONNECTOR:PC (2X18)36 CONTACTS	71785	252-18-30-340
A4XA12	1251-2134		CONNECTOR:PC (2X18)36 CONTACTS	71785	252-18-30-340
A4XA13	1251-2134		CONNECTOR:PC (2X18)36 CONTACTS	71785	252-18-30-340
A4XA14	1251-2134		CONNECTOR:PC (2X18)36 CONTACTS	71785	252-18-30-340
A4XA15	1251-2134		CONNECTOR:PC (2X18)36 CONTACTS	71785	252-18-30-340
A4XA16	1251-2134		CONNECTOR:PC (2X18)36 CONTACTS	71785	252-18-30-340
A4XA17	1251-2134	13	CONNECTOR:PC (2X18)36 CONTACTS	71785	252-18-30-340
A4XA18	1251-2134		CONNECTOR:PC (2X18)36 CONTACTS	71785	252-18-30-340
A4XA19	1251-2134		CONNECTOR:PC (2X18)36 CONTACTS	71785	252-18-30-340
A4XA20	1251-1886		CONN:PC 30-CONTACT (2X15)	71785	252-15-30-340
A4XA21	1251-1886		CONN:PC 30-CONTACT (2X15)	71785	252-15-30-340
A4XA22	1251-1886		CONN:PC 30-CONTACT (2X15)	71785	252-15-30-340
A4XA23	1251-1886		CONN:PC 30-CONTACT (2X15)	71785	252-15-30-340
A4XA24	1251-1886		CONN:PC 30-CONTACT (2X15)	71785	252-15-30-340
A4XA25	1251-1886		CONN:PC 30-CONTACT (2X15)	71785	252-15-30-340
A4XA26	1251-1886		CONN:PC 30-CONTACT (2X15)	71785	252-15-30-340
A4XA27	1251-1886		CONN:PC 30-CONTACT (2X15)	71785	252-15-30-340
A4XA28	1251-1886		CONN:PC 30-CONTACT (2X15)	71785	252-15-30-340
A4XA29	1251-1886		CONN:PC 30-CONTACT (2X15)	71785	252-15-30-340
A4XA30	1251-1886	CONN:PC 30-CONTACT (2X15)	71785	252-15-30-340	
A4XA31	1251-1886	CONN:PC 30-CONTACT (2X15)	71785	252-15-30-340	
A4XA32	1251-1886	CONN:PC 30-CONTACT (2X15)	71785	252-15-30-340	
A4XA33		NOT ASSIGNED			
A4XA34		NOT ASSIGNED			
A4XA35		NOT ASSIGNED			
A4XA36		NOT ASSIGNED			
A4XA37	1251-1558	1	CONNECTOR:PC EDGE 1 ROW 15 CONTACT	71785	252-15-30-350

See introduction to this section for ordering information

Table 6-1. Replaceable Parts

Reference Designation	HP Part Number	Qty	Description	Mfr Code	Mfr Part Number
A5	03330-66505	1	DIGITAL OUTPUT ASSEMBLY	28480	03330-66505
A5 (REBUILT)	03330-69505		DIGITAL OUTPUT ASSEMBLY (REBUILT)	28480	03330-69505
A5C1	0140-0151	2	CAPACITOR-FXC 320PF +-2% 300WVDC MICA	72136	DM15F821G0300WV1CR
A5C2	0140-0151		CAPACITOR-FXC 320PF +-2% 300WVDC MICA	72136	DM15F821G0300WV1CR
A5C3	0180-1746	30	CAPACITOR-FXD 15UF+ 10% 20VDC TA	56289	150D156X9020R2
A5C4	0180-1746		CAPACITOR-FXD 15UF+ 10% 20VDC TA	56289	150D156X9020R2
A5C5	0180-1746		CAPACITOR-FXD 15UF+ 10% 20VDC TA	56289	150D156X9020R2
A5C6	0130-1746		CAPACITOR-FXD 15UF+ 10% 20VDC TA	56289	150D156X9020R2
A5J1	1251-3141	1	CONNECTOR 50-PIN M RECTANGULAR	76381	3433 1002
A5L1	9100-1618	29	COIL-MLD 5.6UH 10% Q=45 .155DX.375LG	24226	15/561
A5L2	9100-1618		COIL-MLD 5.6UH 10% Q=45 .155DX.375LG	24226	15/561
A5L3	9100-1618		COIL-MLD 5.6UH 10% Q=45 .155DX.375LG	24226	15/561
A5L4	9100-1618		COIL-MLD 5.6UH 10% Q=45 .155DX.375LG	24226	15/561
A5AP1	4040 0743	2	EXTRACTOR-PC BD BLK POLYC .062-30 THKNS	23480	4040 0743
A5AP2	4040-0743		EXTRACTOR-PC BD BLK POLYC .062-30 THKNS	23480	4040-0743
A5R1	0684-1021	52	RESISTOR 1K 10% .25W FC TC=+400/+600	01121	CP1021
A5R2	0684-3311	6	RESISTOR 330 10% .25W FC TC=+400/+600	01121	CB3311
A5R3	0684-3311		RESISTOR 330 10% .25W FC TC=+400/+600	01121	CB3311
A5R4	0684-1811	2	RESISTOR 180 10% .25W FC TC=+400/+600	01121	CB1811
A5R5	0684-1811		RESISTOR 180 10% .25W FC TC=+400/+600	01121	CB1811
A5U1	1820 0274	4	IC-DIGITAL MC1808P DTL QUAD 2 OR	04713	MC1808P
A5U2	1820-0273	2	IC-DIGITAL MC1806P DTL QUAD 2 AND	04713	MC1806P
A5U3	1820-0238	6	IC-DIGITAL MC1810P DTL QUAD 2 NOR	04713	MC1810P
A5U4	1820 0273		IC-DIGITAL MC1806P DTL QUAD 2 AND	04713	MC1806P
A5U5	1820-0301	3	IC-DIGITAL SN7475N TTL D-TYPE	01295	SN7475N
A5U6	1320-0301		IC-DIGITAL SN7475N TTL D-TYPE	01295	SN7475N
A5U7	1820-0054	33	IC-DIGITAL SN7400N TTL QUAD 2 NAND	01295	SN7400N
A5U8	1820-0077	9	IC-DIGITAL SN7474N TTL DUAL D-TYPE	01295	SN7474N
A5U9	1820 0274		IC-DIGITAL MC1808P DTL QUAD 2 OR	04713	MC1808P
A5U10	1820-0238		IC-DIGITAL MC1810P DTL QUAD 2 NOR	04713	MC1810P
A5U11	1820-0274		IC-DIGITAL MC1808P DTL QUAD 2 OR	04713	MC1808P
A5U12	1820 0258		IC-DIGITAL MC1810P DTL QUAD 2 NOR	04713	MC1810P
A5U13	1820-0274		IC-DIGITAL MC1808P DTL QUAD 2 OR	04713	MC1808P
A5U14	1820-0238		IC-DIGITAL MC1810P DTL QUAD 2 NOR	04713	MC1810P
A5U15	1820-0328	3	IC-DIGITAL SN7402N TTL QUAD 2 NOR	01295	SN7402N
A5U16	1820-0234	2	IC-DIGITAL DM8570N TTL R-S SERIAL-IN	27014	DM8570N
A5U17	1820-0294		IC-DIGITAL DM8570N TTL R-S SERIAL-IN	27014	DM8570N
A5U18	1820-0726	3	IC-DIGITAL SN74199N TTL R-S PRL-IN	01295	SN74199N
A5U19	1820-0726		IC-DIGITAL SN74199N TTL R-S PRL-IN	01295	SN74199N
A5U20	1820 0077		IC-DIGITAL SN7474N TTL DUAL D-TYPE	01295	SN7474N
A5U21	1820-0425	10	IC-DIGITAL SN74100N TTL DUAL D-TYPE	01295	SN74100N
A5U22	1820-0425		IC-DIGITAL SN74100N TTL DUAL D-TYPE	01295	SN74100N
A5U23	1820 0425		IC-DIGITAL SN74100N TTL DUAL D-TYPE	01295	SN74100N
A5U24	1820-0425		IC-DIGITAL SN74100N TTL DUAL D-TYPE	01295	SN74100N
A5U25	1820 0539	8	IC-DIGITAL SN7437N TTL QUAD 2 NAND	01295	SN7437N
A5U26	1820-0539		IC-DIGITAL SN7437N TTL QUAD 2 NAND	01295	SN7437N
A5U27	1820-0425		IC-DIGITAL SN74100N TTL DUAL D-TYPE	01295	SN74100N
A5U28	1820 0425		IC-DIGITAL SN74100N TTL DUAL D-TYPE	01295	SN74100N
A6 (A ONLY) Δ3	03330-66578	1	DIGITAL INPUT ASSEMBLY (3330A STANDARD)	28480	03330-66578
A6C1	0130 1746		CAPACITOR-FXD 15UF+-10% 20VDC TA	56289	150D156X9020R2
A6C2	0130-1746		CAPACITOR-FXD 15UF+ 10% 20VDC TA	56289	150D156X9020R2
A6C3	0180-1746		CAPACITOR-FXD 15UF+-10% 20VDC TA	56289	150D156X9020R2
A6C4	0180-1746		CAPACITOR-FXD 15UF+-10% 20VDC TA	56289	150D156X9020R2
A6C5	0160-3847	22	CAPACITOR-FXD .01UF +100-0% 25WVDC CER	28480	0160-3847
A6C6	0160-3847		CAPACITOR-FXD .01UF +100-0% 25WVDC CER	28480	0160-3847
A6C7	0160-3847		CAPACITOR-FXD .01UF +100-0% 25WVDC CER	28480	0160-3847
A6C8	0160-0938	2	CAPACITOR-FXD 1000PF + 5% 100WVDC MICA	53021	D15C1F102J
A6C9	0160-0938		CAPACITOR-FXD 1000PF + 5% 100WVDC MICA	53021	D15C1F102J
A6C10	0160-2204	4	CAPACITOR-FXD 100PF+-5% 300WVDC MICA	09023	DM15F101J3C
A6L1	9100-1618		COIL-MLD 5.6UH 10% Q=45 .155DX.375LG	24226	15/561
A6L2	9100-1618		COIL-MLD 5.6UH 10% Q=45 .155DX.375LG	24226	15/561
A6L3	9100-1618		COIL-MLD 5.6UH 10% Q=45 .155DX.375LG	24226	15/561
A6L4	9100-1618		COIL-MLD 5.6UH 10% Q=45 .155DX.375LG	24226	15/561
A6R1	0684 2221	23	RESISTOR 2.2K 10% .25W FC TC=+400/+700	01121	CB2221
A6R2	0684-2221		RESISTOR 2.2K 10% .25W FC TC=+400/+700	01121	CB2221
A6R3	0684-2221		RESISTOR 2.2K 10% .25W FC TC=-400/+700	01121	CB2221
A6R4	0684-2221		RESISTOR 2.2K 10% .25W FC TC=-400/+700	01121	CB2221
A6R5*	0757-0461	2	RESISTOR 68.1K 1% .125W F TC=0+100	24546	C4-1/8-T0=6812-F
A6R7	0684-3311		RESISTOR 330 10% .25W FC TC=+400/+600	01121	CB3311
A6R8 Δ4	0684-2221		RESISTOR 2.2K 10% .25W FC TC=+400/+700	01121	CB2221
A6R9 Δ4	0684-2221		RESISTOR 2.2K 10% .25W FC TC=-400/+700	01121	CB2221
A6R12, R13	1810-0136	8	NETWORK-RES 10-PIN-SIP .1-PIN-SPCG	28480	1810-0136

See introduction to this section for ordering information

Table 6-1. Replaceable Parts

Reference Designation	HP Part Number	Qty	Description	Mfr Code	Mfr Part Number
A6U1	1820-0070	4	IC-DIGITAL SN7430N TTL 6 NAND	01295	SN7430N
A6U2	1820-0054		IC-DIGITAL SN7400N TTL QUAD 2 NAND	01295	SN7400N
A6U3	1820-0072	4	IC-DIGITAL SN7450N TTL QUAD 2 AND (C-INV)	01295	SN7450N
A6U4	1820-0054		IC-DIGITAL SN7400N TTL QUAD 2 NAND	01295	SN7400N
A6U5	1820-0074		IC-DIGITAL SN7400N TTL QUAD 2 NAND	01295	SN7400N
A6U6	1820-0418		IC-DIGITAL MC1812P DTL QUAD 2 XOR	04713	MC1812P
A6U7	1820-0418	1	IC-DIGITAL MC1812P DTL QUAD 2 XOR	28480	1820-0418
A6U8	1820-0238		IC-DIGITAL MC1810P DTL QUAD 2 XOR	04713	MC1810P
A6U9	1820-0507	4	IC-DIGITAL SN7412N TTL TPL 3 NAND	01295	SN7412N
A6U10	1820-0056	11	IC-DIGITAL SN7410N TTL TPL 3 NAND	01295	SN7410N
A6U11	1820-0054		IC-DIGITAL SN7400N TTL QUAD 2 NAND	01295	SN7400N
A6U12	1820-0174	15	IC-DIGITAL SN7404N TTL HEX 1	01295	SN7404N
A6U13	1820-0054		IC-DIGITAL SN7400N TTL QUAD 2 NAND	01295	SN7400N
A6U14	1820-0616	8	IC-DIGITAL 9322DC TTL QUAD 2 2-TU-1-LINE	07263	9322DC
A6U15	1820-1042	6	IC-DIGITAL SN74165N TTL R-S TTL IN	01295	SN74165N
A6U16	1820-0174		IC-DIGITAL SN7404N TTL HEX 1	01295	SN7404N
A6U17	1820-0782	4	IC-DIGITAL SN7427N TTL TPL 3 NGR	01295	SN7427N
A6U18	1820-0054		IC-DIGITAL SN7400N TTL QUAD 2 NAND	01295	SN7400N
A6U19	1820-0539		IC-DIGITAL SN7437N TTL QUAD 2 NAND	01295	SN7437N
A6U20	1820-0077		IC-DIGITAL SN7474N TTL DUAL D-TYPE	01295	SN7474N
A6U21	1820-0616		IC-DIGITAL 9322DC TTL QUAD 2 2-TU-1-LINE	07263	9322DC
A6U22	1820-0537	4	IC-DIGITAL SN7413N TTL DUAL 4 NAND	01295	SN7413N
A6U23	1820-0577	4	IC-DIGITAL SN7416N TTL HEX 1	01295	SN7416N
A6U24	1820-0668		IC-DIGITAL SN7410N TTL TPL 3 NAND	01295	SN7410N
A6U25	1820-0174		IC-DIGITAL SN7404N TTL HEX 1	01295	SN7404N
A6U27	1820-0425		IC-DIGITAL SN74100N TTL DUAL D-TYPE	01295	SN74100N
A6U28	1820-0054		IC-DIGITAL SN7400N TTL QUAD 2 NAND	01295	SN7400N
A6W1-W5	11153-01301	5	WIRE JUMPER	28480	11153-01301
A6 (A ONLY) A3	03330-66579	1	DIGITAL INPUT ASSEMBLY (3330A, OPT 004)	28480	03330-66579
A6 (REBUILT)	03330-69579		DIGITAL INPUT ASSEMBLY (REBUILT A OPT 004)	28480	03330-69579
A6 C1	0180 1746		CAPACITOR-FXD 15UF+10% 20VDC TA	56289	150D156X9020R2
A6 C2	0180 1746		CAPACITOR-FXD 15UF+10% 20VDC TA	56289	150D156X9020R2
A6 C3	0180 1746		CAPACITOR-FXD 15UF+10% 20VDC TA	56289	150D156X9020R2
A6 C4	0180 1746		CAPACITOR-FXD 15UF+10% 20VDC TA	56289	150D156X9020R2
A6 C5	0160 3847		CAPACITOR-FXD .01UF +100-0% 25WVDC CER	28480	0160-3847
A6 C6	0160 3847		CAPACITOR-FXD .01UF +100-0% 25WVDC CER	28480	0160-3847
A6 C7	0160 2204		CAPACITOR-FXD 100PF+5% 300VDC MICA	09023	FDML5F101J3C
A6 C8	0180 2050	2	CAPACITOR-FXD .082UF+10% 35VDC TA	56289	150D82X9035A2
A6 C10	0160 1743	2	CAPACITOR-FXD .1UF+10% 35VDC TA	56289	150D104X9035A2
A6 L1	9100 1618		COIL-MLD 5.6UH 10% Q=45 .1550X.375LG	24226	15/561
A6 L2	9100 1618		COIL-MLD 5.6UH 10% Q=45 .1550X.375LG	24226	15/561
A6 L3	9100 1613		COIL-MLD 5.6UH 10% Q=45 .1550X.375LG	24226	15/561
A6 L4	9100 1619		COIL-MLD 5.6UH 10% Q=45 .1550X.375LG	24226	15/561
A6 P154	1590 0400	12	OPTO-ISOLATOR LED-PXSTR IF=60MA-MAX	50522	MCT-6
A6 P155	1590 0400		OPTO-ISOLATOR LED-PXSTR IF=60MA-MAX	50522	MCT-6
A6 P156	1590 0400		OPTO-ISOLATOR LED-PXSTR IF=60MA-MAX	50522	MCT-6
A6 P157	1590 0400		OPTO-ISOLATOR LED-PXSTR IF=60MA-MAX	50522	MCT-6
A6 P158	1590 0400		OPTO-ISOLATOR LED-PXSTR IF=60MA-MAX	50522	MCT-6
A6 Q2	1854 0354	22	TRANSISTOR NPN SI TO-52 PD=360MW	28480	1854-0354
A6 Q3	1854 0354		TRANSISTOR NPN SI TO-52 PD=360MW	28480	1854-0354
A6 Q4	1854 0354		TRANSISTOR NPN SI TO-52 PD=360MW	28480	1854-0354
A6 Q5	1854 0354		TRANSISTOR NPN SI TO-52 PD=360MW	28480	1854-0354
A6 Q6	1854 0354		TRANSISTOR NPN SI TO-52 PD=360MW	28480	1854-0354
A6 Q7	1854 0354		TRANSISTOR NPN SI TO-52 PD=360MW	28480	1854-0354
A6 Q8	1854 0354		TRANSISTOR NPN SI TO-52 PD=360MW	28480	1854-0354
A6 Q9	1854 0354	2	TRANSISTOR NPN SI TO-46 PD=500MW	28480	1854-0354
A6 Q10	1854 0354		TRANSISTOR NPN SI TO-52 PD=360MW	28480	1854-0354
A6 Q11	1854 0354		TRANSISTOR NPN SI TO-52 PD=360MW	28480	1854-0354
A6 Q12	1854 0354		TRANSISTOR NPN SI TO-52 PD=360MW	28480	1854-0354
A6 Q13	1854 0354		TRANSISTOR NPN SI TO-52 PD=360MW	28480	1854-0354
A6 R1	0684 2221		RESISTOR 2.2K 10% .25W F C TC=-400/+700	01121	CR2221
A6 R2	1810 0136		NETWORK RES 10-PIN-SIP .1 PIN-SPCG	28480	1810-0136
A6 R3	1810 0136		NETWORK RES 10-PIN-SIP .1 PIN-SPCG	28480	1810-0136
A6 R4	0684 2221		RESISTOR 2.2K 10% .25W F C TC=-400/+700	01121	CR2221
A6 R5*	0757 0461		RESISTOR 68.1K 1% .125W F TC=0+-100	24546	C4-1/8-T0-681?-F
A6 R7	0684 3311		RESISTOR 330 10% .25W F C TC=-400/+600	C1121	CR3311
A6 R9-36	0684 1021		RESISTOR 1K 10% .25W F C TC=-400/+600	C1121	CR1021
A6 R10	0628 3487	24	RESISTOR 255 1% .125W F TC=0+-100	16299	C4-1/8-T0-255R-F
A6 R11	0628 3437		RESISTOR 255 1% .125W F TC=0+-100	16299	C4-1/8-T0-255R-F
A6 R12	0628 3487		RESISTOR 255 1% .125W F TC=0+-100	16299	C4-1/8-T0-255R-F

See introduction to this section for ordering information

Table 6-1. Replaceable Parts

Reference Designation	HP Part Number	Qty	Description	Mfr Code	Mfr Part Number
A6 R13	0698-3487		RESISTOR 255 1% .125W F TC=0+-100	16299	C4-1/8-T0-255R-F
A6 R14	0698-3487		RESISTOR 255 1% .125W F TC=0+-100	16299	C4-1/8-T0-255R-F
A6 R15	0698-3487		RESISTOR 255 1% .125W F TC=0+-100	16299	C4-1/8-T0-255R-F
A6 R16	0698-3487		RESISTOR 255 1% .125W F TC=0+-100	16299	C4-1/8-T0-255R-F
A6 R17	0698-3487		RESISTOR 255 1% .125W F TC=0+-100	16299	C4-1/8-T0-255R-F
A6 R18	0698-3487		RESISTOR 255 1% .125W F TC=0+-100	16299	C4-1/8-T0-255R-F
A6 R19	0698-3487		RESISTOR 255 1% .125W F TC=0+-100	16299	C4-1/8-T0-255R-F
A6 R20	0698-3487		RESISTOR 255 1% .125W F TC=0+-100	16299	C4-1/8-T0-255R-F
A6 R21	0698-3487		RESISTOR 255 1% .125W F TC=0+-100	16299	C4-1/8-T0-255R-F
A6 R22	0684-1021		RESISTOR 1K 10% .25W FC TC=-400/+600	C1121	CR1021
A6 R23	0684-1021		RESISTOR 1K 10% .25W FC TC=-400/+600	C1121	CR1021
A6 R24	0684-1021		RESISTOR 1K 10% .25W FC TC=-400/+600	C1121	CR1021
A6 R25	0684-1021		RESISTOR 1K 10% .25W FC TC=-400/+600	C1121	CR1021
A6 R26	0684-1021		RESISTOR 1K 10% .25W FC TC=-400/+600	C1121	CR1021
A6 R27	0684-1021		RESISTOR 1K 10% .25W FC TC=-400/+600	C1121	CR1021
A6 R28	0684-1021		RESISTOR 1K 10% .25W FC TC=-400/+600	C1121	CR1021
A6 R29	0684-1021		RESISTOR 1K 10% .25W FC TC=-400/+600	C1121	CR1021
A6 R30	0684-1021		RESISTOR 1K 10% .25W FC TC=-400/+600	C1121	CR1021
A6 R31	0684-1021		RESISTOR 1K 10% .25W FC TC=-400/+600	C1121	CR1021
A6 R32	0684-1021		RESISTOR 1K 10% .25W FC TC=-400/+600	C1121	CR1021
A6 R33	0684-1021		RESISTOR 1K 10% .25W FC TC=-400/+600	C1121	CR1021
A6 R34	0684-1021		RESISTOR 1K 10% .25W FC TC=-400/+600	C1121	CR1021
A6 R35	0684-1021		RESISTOR 1K 10% .25W FC TC=-400/+600	C1121	CR1021
A6 R36	0684-1021		RESISTOR 1K 10% .25W FC TC=-400/+600	C1121	CR1021
A6 R37	0684-1021		RESISTOR 1K 10% .25W FC TC=-400/+600	C1121	CR1021
A6 R38	0684-1021		RESISTOR 1K 10% .25W FC TC=-400/+600	C1121	CR1021
A6 R39	0684-1021		RESISTOR 1K 10% .25W FC TC=-400/+600	C1121	CR1021
A6 R40	0684-1021		RESISTOR 1K 10% .25W FC TC=-400/+600	C1121	CR1021
A6 R41	0684-1021		RESISTOR 1K 10% .25W FC TC=-400/+600	C1121	CR1021
A6 R42	0684-1021		RESISTOR 1K 10% .25W FC TC=-400/+600	C1121	CR1021
A6 R43	0684-1021		RESISTOR 1K 10% .25W FC TC=-400/+600	C1121	CR1021
A6 R44	0684-1021		RESISTOR 1K 10% .25W FC TC=-400/+600	C1121	CR1021
A6 R45	0684-1021		RESISTOR 1K 10% .25W FC TC=-400/+600	C1121	CR1021
A6 R46	0684-2221		RESISTOR 2.2K 10% .25W FC TC=-400/+700	C1121	CR2221
A6 R47	0684-1031	4	RESISTOR 10K 10% .25W FC TC=-400/+700	C1121	CR1031
A6 R48	0684-1031		RESISTOR 10K 10% .25W FC TC=-400/+700	C1121	CR1031
A6 R49	0684-1031		RESISTOR 10K 10% .25W FC TC=-400/+700	C1121	CR1031
A6 R50	0684-1031		RESISTOR 10K 10% .25W FC TC=-400/+700	C1121	CR1031
A6 R51	0757-0413	2	RESISTOR 392 1% .125W F TC=0+-100	24546	C4-1/8-T0-392R-F
A6 U1	1820-0070		IC-DIGITAL SN7430N TTL 8 NAND	01295	SN7430N
A6 U2	1820-0054		IC-DIGITAL SN7400N TTL QUAD 2 NAND	01295	SN7400N
A6 U3	1820-0072		IC-DIGITAL SN7450N TTL DUAL 2 NAND-GATE INV	01295	SN7450N
A6 U4	1820-0054		IC-DIGITAL SN7400N TTL QUAD 2 NAND	01295	SN7400N
A6 U5	1820-0054		IC-DIGITAL SN7400N TTL QUAD 2 NAND	01295	SN7400N
A6 U6	1820-0418	6	IC-DIGITAL MC1812P DTL QUAD 2 EXCL-OR	04713	MC1812P
A6 U7	1820-0418		IC-DIGITAL MC1812P DTL QUAD 2 EXCL-OR	04713	MC1812P
A6 U8	1820-0238		IC-DIGITAL MC1810P DTL QUAD 2 NOR	04713	MC1810P
A6 U9	1820-0068		IC-DIGITAL SN7410N TTL TPL 3 NAND	01295	SN7410N
A6 U10	1820-0068		IC-DIGITAL SN7410N TTL TPL 3 NAND	01295	SN7410N
A6 U11	1820-0054		IC-DIGITAL SN7400N TTL QUAD 2 NAND	01295	SN7400N
A6 U12	1820-0174		IC-DIGITAL SN7404N TTL HEX 1	01295	SN7404N
A6 U13	1820-0054		IC-DIGITAL SN7400N TTL QUAD 2 NAND	01295	SN7400N
A6 U14	1820-0816		IC-DIGITAL 9322DC TTL QUAD 2 2-TO-1-LINE	07263	9322DC
A6 U15	1820-1042		IC-DIGITAL SN74165N TTL 4-S PRL-IN	01295	SN74165N
A6 U16	1820-1053	2	IC-DIGITAL SN7414N TTL HEX 1	01295	SN7414N
A6 U17	1820-0782		IC-DIGITAL SN7427N TTL TPL 3 NOR	01295	SN7427N
A6 U18	1820-0054		IC-DIGITAL SN7400N TTL QUAD 2 NAND	01295	SN7400N
A6 U19	1820-0539		IC-DIGITAL SN7437N TTL QUAD 2 NAND	01295	SN7437N
A6 U20	1820-0077		IC-DIGITAL SN7474N TTL DUAL D-TYPE	01295	SN7474N
A6 U21	1820-0907		IC-DIGITAL SN7412N TTL TPL 3 NAND	01295	SN7412N
A6 U22	1820-0616		IC-DIGITAL 9322DC TTL QUAD 2 2-TO-1-LINE	07263	9322DC
A6 U23	1820-0577		IC-DIGITAL SN7416N TTL HEX 1	01295	SN7416N
A6 U24	1820-0068		IC-DIGITAL SN7410N TTL TPL 3 NAND	01295	SN7410N
A6 U25	1820-0174		IC-DIGITAL SN7404N TTL HEX 1	01295	SN7404N
A6 U26	1820-0174		IC-DIGITAL SN7404N TTL HEX 1	01295	SN7404N
A6 U27	1820-0425		IC-DIGITAL SN74100N TTL DUAL D-TYPE	01295	SN74100N
A6 U28	1820-0054		IC-DIGITAL SN7400N TTL QUAD 2 NAND	01295	SN7400N
A6 U29	1820-0668	4	IC-DIGITAL SN7407N TTL HEX 1 NON-INV	01295	SN7407N
A6 U30	1820-0668		IC-DIGITAL SN7407N TTL HEX 1 NON-INV	01295	SN7407N
A6 U31	1820-0537		IC-DIGITAL SN7413N TTL DUAL 4 NAND	01295	SN7413N
A6 W1-W5	11153-01301	5	WIRE-JUMPER	28480	11153-01301
A6 (B ONLY) Δ3	03330-66576	1	DIGITAL INPUT ASSEMBLY (33308 STANDARD)	28480	03330-66576
A6 (REBUILT)	03330-69576		DIGITAL INPUT ASSEMBLY (REBUILT B STD)	28480	03330-69576
A6 C1	0180-1746		CAPACITOR-FXC 15UF+-10% 20VDC TA	56289	150D156X9020B2
A6 C2	0180-1746		CAPACITOR-FXD 15UF+-10% 20VDC TA	56289	150D156X9020B2
A6 C3	0180-1746		CAPACITOR-FXD 15UF+-10% 20VDC TA	56289	150D156X9020B2
A6 C4	0180-1746		CAPACITOR-FXD 15UF+-10% 20VDC TA	56289	150D156X9020B2
A6 C5	0160-3847		CAPACITOR-FXD .01UF +100-0% 25VDC CER	28480	0160-3847

See introduction to this section for ordering information

Table 6-1. Replaceable Parts

Reference Designation	HP Part Number	Qty	Description	Mfr Code	Mfr Part Number
A6 C6	0160-3347	2	CAPACITOR-FXD .010F +100-0% 25WVDC CER	28480	0160-3347
A6 C7	0160-3347		CAPACITOR-FXD .010F +100 0% 25WVDC CER	28480	0160-3347
A6 C8	0160-0938		CAPACITOR-FXL 110PF +1% 300WVDC MICA	29480	0160-0938
A6 C9	0160-0938		CAPACITOR-FXD 110PF +1% 300WVDC MICA	28480	0160-0938
A6 D10	0160-2204		CAPACITOR-FXD 100PF+ 5% 300WVDC MICA	09023	F0M15F101J3C
A6 L1	9100-1618	2	COIL MLD 5.6UH 10% Q=45 .1550X.375LG	24226	15/561
A6 L2	9100-1618		COIL MLD 5.6UH 10% Q=45 .1550X.375LG	24226	15/561
A6 L3	9100-1618		COIL MLD 5.6UH 10% Q=45 .1550X.375LG	24226	15/561
A6 L4	9100-1618		COIL MLD 5.6UH 10% Q=45 .1550X.375LG	24226	15/561
A6 R1	0684-2221	2	RESISTOR 2.2K 10% .25W FC TC=-400/+700	01121	CR2221
A6 R2	0684-2221		RESISTOR 2.2K 10% .25W FC TC=-400/+700	01121	CR2221
A6 R3	0684-2221	2	RESISTOR 2.2K 10% .25W FC TC=-400/+700	01121	CR2221
A6 R4	0684-2221	2	RESISTOR 2.2K 10% .25W FC TC=-400/+700	01121	CR2221
A6 R5	0160-2221	2	RESISTOR 2.2K 10% .25W FC TC=-400/+700	01121	CR2221
A6 R6	0160-2221	2	RESISTOR 2.2K 10% .25W FC TC=-400/+700	01121	CR2221
A6 R7	0684-2221	2	RESISTOR 2.2K 10% .25W FC TC=-400/+700	01121	CR2221
A6 R8	0684-2221	2	RESISTOR 2.2K 10% .25W FC TC=-400/+700	01121	CR2221
A6 R9	0684-2221	2	RESISTOR 2.2K 10% .25W FC TC=-400/+700	01121	CR2221
A6 R10	0684-2221	2	RESISTOR 2.2K 10% .25W FC TC=-400/+700	01121	CR2221
A6 R11	0684-2221	2	RESISTOR 2.2K 10% .25W FC TC=-400/+700	01121	CR2221
A6 R12, R13	1810-0136	2	NETWORK-RES 10-PIN-SIP .1-PIN-SPCG	28480	1820-0136
A6 U1	1820-0070	5	IC-DIGITAL SN7430N TTL 8 NAND	01295	SN7430N
A6 U2	1820-0070		IC-DIGITAL SN7400N TTL QUAD 2 NAND	01295	SN7400N
A6 U3	1820-0070		IC-DIGITAL SN7450N TTL DUAL 2 AND-OR-INV	01295	SN7450N
A6 U4	1820-0070		IC-DIGITAL SN7400N TTL QUAD 2 NAND	01295	SN7400N
A6 U5	1820-0070		IC-DIGITAL SN7400N TTL QUAD 2 NAND	01295	SN7400N
A6 U6	1820-0413		IC-DIGITAL MC1812P DTL QUAD 2 EXCL-OR	04713	MC1812P
A6 U7	1820-0413		IC-DIGITAL MC1812P DTL QUAD 2 EXCL-OR	04713	MC1812P
A6 U8	1820-0235		IC-DIGITAL MC1810P DTL QUAD 2 NOR	04713	MC1810P
A6 U9	1820-0507		IC-DIGITAL SN7412N TTL TPL 3 NAND	01295	SN7412N
A6 U10	1820-0049		IC-DIGITAL SN7410N TTL TPL 3 NAND	01295	SN7410N
A6 U11	1820-0054		IC-DIGITAL SN7400N TTL QUAD 2 NAND	01295	SN7400N
A6 U12	1820-0174		IC-DIGITAL SN7404N TTL HEX 1	01295	SN7404N
A6 U13	1820-0054		IC-DIGITAL SN7400N TTL QUAD 2 NAND	01295	SN7400N
A6 U14	1820-0616		IC-DIGITAL 93220C TTL QUAD 2 2-TN-1-LINE	07263	93220C
A6 U15	1820-1042		IC-DIGITAL SN74165N TTL 4-S PRE-1N	01295	SN74165N
A6 U16	1820-0174		IC-DIGITAL SN7404N TTL HEX 1	01295	SN7404N
A6 U17	1820-0742	IC-DIGITAL SN7427N TTL TPL 3 NOR	01295	SN7427N	
A6 U18	1820-0054	IC-DIGITAL SN7400N TTL QUAD 2 NAND	01295	SN7400N	
A6 U19	1820-0537	IC-DIGITAL SN7437N TTL QUAD 2 NAND	01295	SN7437N	
A6 U20	1820-0077	IC-DIGITAL SN7474N TTL DUAL 0-TYPE	01295	SN7474N	
A6 U21	1820-0616	5	IC-DIGITAL 93220C TTL QUAD 2 2-TN-1-LINE	07263	93220C
A6 U22	1820-0337		IC-DIGITAL SN7413N TTL DUAL 4 NAND	01295	SN7413N
A6 U23	1820-0134		IC-DIGITAL MC7270P TTL	04713	MC7270P
A6 U24	1820-0577		IC-DIGITAL SN7416N TTL HEX 1	01295	SN7416N
A6 U25	1820-0068		IC-DIGITAL SN7410N TTL TPL 3 NAND	01295	SN7410N
A6 U26	1820-0174	5	IC-DIGITAL SN7404N TTL HEX 1	01295	SN7404N
A6 U27	1820-0425		IC-DIGITAL SN74100N TTL DUAL 0-TYPE	01295	SN74100N
A6 U28	1820-0054		IC-DIGITAL SN7400N TTL QUAD 2 NAND	01295	SN7400N
A6 W1-W5	11153-01301	5	WIREJUMPER	28480	11153-01301
A6 (B ONLY) D3	J3330-66577	1	DIGITAL INPUT ASSEMBLY (33303, OPT 004)	28480	03330-66577
A6 (REBUILT)	03330-69577		DIGITAL INPUT ASSEMBLY (REBUILT B OPT 004)	28480	03330-69577
A6 C1	0160-1746	2	CAPACITOR-FXD 150F+10% 20VDC TA	56289	150D156X9020R2
A6 C2	0160-1746		CAPACITOR-FXD 150F+10% 20VDC TA	56289	150D156X9020R2
A6 C3	0160-1746		CAPACITOR-FXD 150F+10% 20VDC TA	56289	150D156X9020R2
A6 C4	0160-1746		CAPACITOR-FXD 150F+10% 20VDC TA	56289	150D156X9020R2
A6 C5	0160-1746		CAPACITOR-FXD 150F+10% 20VDC TA	56289	150D156X9020R2
A6 C6	0160-3847		CAPACITOR-FXD .010F +100-0% 25WVDC CER	28480	0160-3847
A6 C7	0160-3347		CAPACITOR-FXD .010F +100-0% 25WVDC CER	28480	0160-3347
A6 C8	0160-3347		CAPACITOR-FXD .010F +100 0% 25WVDC CER	28480	0160-3347
A6 C9	0160-2204		CAPACITOR-FXD 100PF+ 5% 300WVDC MICA	09023	F0M15F101J3C
A6 C10	0160-2050		CAPACITOR-FXD .0820F+ 10% 25WVDC TA	56289	150D82X9035A2
A6 C11	0160-1743	CAPACITOR-FXD .10F+ 10% 35VDC TA	56289	150D104X9025A2	
A6 L1	9100-1618	2	COIL MLD 5.6UH 10% Q=45 .1550X.375LG	24226	15/561
A6 L2	9100-1618		COIL MLD 5.6UH 10% Q=45 .1550X.375LG	24226	15/561
A6 L3	9100-1618		COIL MLD 5.6UH 10% Q=45 .1550X.375LG	24226	15/561
A6 L4	9100-1618		COIL MLD 5.6UH 10% Q=45 .1550X.375LG	24226	15/561
A6 C18C	1990-0400	2	OPTO-ISOLATOR LED-PXSTR IF=60MA-MAX	50522	MCT-6
A6 C18D	1990-0400		OPTO-ISOLATOR LED-PXSTR IF=60MA-MAX	50522	MCT-6
A6 C18E	1990-0400		OPTO-ISOLATOR LED-PXSTR IF=60MA-MAX	50522	MCT-6
A6 C18F	1990-0400		OPTO-ISOLATOR LED-PXSTR IF=60MA-MAX	50522	MCT-6
A6 C18G	1990-0400		OPTO-ISOLATOR LED-PXSTR IF=60MA-MAX	50522	MCT-6

See introduction to this section for ordering information

Table 6-1. Replaceable Parts

Reference Designation	HP Part Number	Qty	Description	Mfr Code	Mfr Part Number
A6 U11	1820-0054		IC-DIGITAL SN7400N TTL QUAD 2 NAND	01295	SN7400N
A6 U12	1820-0174		IC-DIGITAL SN7404N TTL HEX 1	01295	SN7404N
A6 U13	1820-0054		IC-DIGITAL SN7400N TTL QUAD 2 NAND	01295	SN7400N
A6 U14	1820-0615		IC-DIGITAL 93220C TTL QUAD 2 2-TO-1-LINE	07263	93220C
A6 U15	1820-1042		IC-DIGITAL SN74165N TTL 2-3 PRL-IN	01295	SN74165N
A6 U16	1820-1053		IC-DIGITAL SN7414N TTL HEX 1	01295	SN7414N
A6 U17	1820-0702		IC-DIGITAL SN7427N TTL TPL 3 NOR	01295	SN7427N
A6 U18	1820-0054		IC-DIGITAL SN7400N TTL QUAD 2 NAND	01295	SN7400N
A6 U19	1820-0537		IC-DIGITAL SN7437N TTL QUAD 2 NAND	01295	SN7437N
A6 U20	1820-0077		IC-DIGITAL SN7474N TTL DUAL D-TYPE	01295	SN7474N
A6 U21	1820-0707		IC-DIGITAL SN7412N TTL TPL 3 NAND	01295	SN7412N
A6 U22	1820-0615		IC-DIGITAL 93220C TTL QUAD 2 2-TO-1-LINE	07263	93220C
A6 U23	1820-0704		IC-DIGITAL MC7270P TTL	04713	MC7270P
A6 U24	1820-0577		IC-DIGITAL SN7416N TTL HEX 1	01295	SN7416N
A6 U25	1820-0055		IC-DIGITAL SN7410N TTL TPL 3 NAND	01295	SN7410N
A6 U26	1820-0174		IC-DIGITAL SN7404N TTL HEX 1	01295	SN7404N
A6 U27	1820-0425		IC-DIGITAL SN74100N TTL DUAL D-TYPE	01295	SN74100N
A6 U28	1820-0054		IC-DIGITAL SN7400N TTL QUAD 2 NAND	01295	SN7400N
A6 U29	1820-0664		IC-DIGITAL SN7407N TTL HEX 1 NON-INV	01295	SN7407N
A6 U30	1820-0665		IC-DIGITAL SN7407N TTL HEX 1 NON-INV	01295	SN7407N
A6 U31	1820-0537		IC-DIGITAL SN7413N TTL DUAL 4 NAND	01295	SN7413N
A6 W1-W5	11153-01301	5	WIRE JUMPER	28480	11153-01301
A7	03330-66507	1	CPU ASSEMBLY	28480	03330-66507
A7 (REBUILT)	03330-69507		CPU ASSEMBLY (REBUILT)	28480	03330-69507
A7U1	0150-1745		CAPACITOR-FXD 15UF+10% 20VDC TA	56289	150D156X9020B2
A7U2	0150-3847		CAPACITOR-FXD .01UF +100-0% 25WVDC CER	28480	0150-3847
A7U3	0130-1745		CAPACITOR-FXD 15UF+10% 20VDC TA	56289	150D156X9020B2
A7U4	0150-3847		CAPACITOR-FXD .01UF +100-0% 25WVDC CER	28480	0150-3847
A7U5	0130-1745		CAPACITOR-FXD 15UF+10% 20VDC TA	56289	150D156X9020B2
A7U6	0150-3847		CAPACITOR-FXD .01UF +100-0% 25WVDC CER	28480	0150-3847
A7U7	0180-1746		CAPACITOR-FXD 15UF+10% 20VDC TA	56209	150D156X9020B2
A7U8	0150-3847		CAPACITOR-FXD .01UF +100-0% 25WVDC CER	28480	0150-3847
A7U9	0150-1746		CAPACITOR-FXD 15UF+10% 20VDC TA	56209	150D156X9020B2
A7U10	0140-0149	1	CAPACITOR-FXD 470PF +5% 300WVDC MIC	72136	DM15F471J0300WV1CP
A7U11	1901-0040	1	DIODE-SWITCHING 30V 50MA 2NS DC 35	20480	1901-0040
A7J1	1200-0424	5	SOCKET:IC BLK 14 CONTACT	23880	CSA2900-14B
A7J2	1200-0424		SOCKET:IC BLK 14 CONTACT	23880	CSA2900-14B
A7L1	9100-1618		COIL-MLD 5.6UH 10% Q=45 .155DX.375LG	24226	15/561
A7L2	9100-1618		COIL-MLD 5.6UH 10% Q=45 .155DX.375LG	24226	15/561
A7L3	9100-1618		COIL-MLD 5.6UH 10% Q=45 .155DX.375LG	24226	15/561
A7L4	9100-1618		COIL-MLD 5.6UH 10% Q=45 .155DX.375LG	24226	15/561
A7L5	9100-1618		COIL-MLD 5.6UH 10% Q=45 .155DX.375LG	24226	15/561
A7M1	4040-0750	2	EXTRACTOR-PC RD RED POLYLC .062-BD THKNS	28480	4040-0750
A7M2	4040-0750		EXTRACTOR-PC RD RED POLYLC .062-BD THKNS	28480	4040-0750
A7N1	0684-4721	2	RESISTOR 4.7K 10% .25W FC TC= 400/+700	01121	C84721
A7N2	0684-2721	2	RESISTOR 2.7K 10% .25W FC TC= 400/+700	01121	C82721
A7N3	0684-2721		RESISTOR 2.7K 10% .25W FC TC= 400/+700	01121	C82721
A7N4	0684-1021		RESISTOR 1K 10% .25W FC TC= 400/+600	01121	C81021
A7N5	0684-2921	1	RESISTOR 3.9K 10% .25W FC TC= 400/+700	01121	C83921
A7N6	0684-1021		RESISTOR 1K 10% .25W FC TC= 400/+600	01121	C81021
A7N7	1810-0041	7	NETWORK-RES 9-PIN-SIP .15 PIN SPCG	28480	1810-0041
A7N8	0684-2221		RESISTOR 2.2K 10% .25W FC TC=400/+700	01121	C82221
A7N9	0684-1021		RESISTOR 1K 10% .25W FC TC=400/+600	01121	C81021
A7N10	0684-5611	1	RESISTOR 560 10% .25W FC TC= 400/+600	01121	C85611
A7U1	1820-0055	6	IC-DIGITAL SN7490N TTL DECD SYNCHRD	01295	SN7490N
A7U2	1820-0055		IC-DIGITAL SN7490N TTL DECD SYNCHRD	01295	SN7490N
A7U3	1820-0055		IC-DIGITAL SN7490N TTL DECD SYNCHRD	01295	SN7490N
A7U4	1820-0077		IC-DIGITAL SN7474N TTL DUAL D-TYPE	01295	SN7474N
A7U5	1820-0281	2	IC-DIGITAL SN74107N TTL DUAL J-K M/S	01295	SN74107N

See introduction to this section for ordering information

Table 6-1. Replaceable Parts

Reference Designation	HP Part Number	Qty	Description	Mfr Code	Mfr Part Number
A706	1820-0539	1	IC-DIGITAL SN7437N TTL QUAD 2 NAND	01295	SN7437N
A707	1816-0039	1	IC 1K ROM TTL	28480	1816-0039
A708	1820-0544	2	IC-DIGITAL SN74H103N TTL H DUAL J-K	01295	SN74H103N
A709	1820-1642	1	IC-DIGITAL SN74165N TTL 8-S PRL-IN	01295	SN74165N
A710	1820-0055	1	IC-DIGITAL SN7490N TTL DDEC SYNCHRO	01295	SN7490N
A711	1820-0231	1	IC-DIGITAL SN74107N TTL DUAL J-K M/S	01295	SN74107N
A712	1820-0372	1	IC-DIGITAL SN74H11N TTL H TPL 3 AND	01295	SN74H11N
A713	1820-0655	1	IC-DIGITAL SN7425N TTL DUAL 4 AND	01295	SN7425N
A714	1820-0511	3	IC-DIGITAL SN7408N TTL QUAD 2 AND	01295	SN7408N
A715	1820-0084	2	IC-DIGITAL SN7453N TTL AND-OR INV	01295	SN7453N
A716	1820-0084	1	IC-DIGITAL SN7453N TTL AND-OR INV	01295	SN7453N
A717	1820-0174	1	IC-DIGITAL SN7404N TTL HEX 1	01295	SN7404N
A718	1820-1062	1	IC-DIGITAL SN74165N TTL 8-S PRL-IN	01295	SN74165N
A719	1820-0055	1	IC-DIGITAL SN7490N TTL DDEC SYNCHRO	01295	SN7490N
A720	1820-0054	1	IC-DIGITAL SN7400N TTL QUAD 2 NAND	01295	SN7400N
A721	1820-0511	1	IC-DIGITAL SN7408N TTL QUAD 2 AND	01295	SN7408N
A722	1820-0400	1	IC-DIGITAL N8281A TTL 8IN ASYNCHRO	18324	N8281A
A723	1820-0664	2	IC-DIGITAL SHIFT REG MEM 8X16 BIT	23490	1820-0664
A724	1820-0664	1	IC-DIGITAL SHIFT REG MEM 8X16 BIT	23490	1820-0664
A725	1820-0984	1	IC-DIGITAL MC7270P TTL	04713	MC7270P
A726	1820-0323	1	IC-DIGITAL SN7402N TTL QUAD 2 NOR	01295	SN7402N
A727	1820-0055	1	IC-DIGITAL SN7490N TTL DDEC SYNCHRO	01295	SN7490N
A728	1820-0859	3	IC-DIGITAL SN74175N TTL QUAD D-TYPE	01295	SN74175N
A729	1820-0068	1	IC-DIGITAL SN7410N TTL TPL 3 NAND	01295	SN7410N
A730	1820-0726	1	IC-DIGITAL SN74199N TTL 8-S PRL-IN	01295	SN74199N
A731	1820-0328	1	IC-DIGITAL SN7402N TTL QUAD 2 NOR	01295	SN7402N
A732	1820-0584	1	IC-DIGITAL MC7270P TTL	04713	MC7270P
A733	1820-0984	1	IC-DIGITAL MC7270P TTL	04713	MC7270P
A734	1820-0054	1	IC-DIGITAL SN7400N TTL QUAD 2 NAND	01295	SN7400N
A7W1-W16	11153-01301	16	WIREJUMPER	28480	11153-01301
A7AJT	1200-0767	17	SOCKET-IC 16-CONT DIP-SLDR-TERMS	91506	316-4650-3P
A7X023	1200-0767	1	SOCKET-IC 16-CONT DIP-SLDR-TERMS	91506	316-4650-3R
A7X024	1200-0767	1	SOCKET-IC 16-CONT DIP-SLDR-TERMS	91506	316-4650-3R
A8 A3	03330-66375	1	CONTROL ASSEMBLY (REBUILT)	23490	03330-66375
A8 (REBUILT)	03330-69575	1	CONTROL ASSEMBLY (REBUILT)	28480	03330-69575
A8C1	0180-1746	1	CAPACITOR-FXD 150F+10% 20VDC TA	56289	150F156X9020R2
A8C2	0180-1746	1	CAPACITOR-FXD 150F+10% 20VDC TA	56289	150F156X9020R2
A8C3	0180-1746	1	CAPACITOR-FXD 150F+10% 20VDC TA	56289	150F156X9020R2
A8C4	0160-3847	1	CAPACITOR-FXD .01UF +20% 0% 25WVDC CER	28480	0160-3847
A8C5	0160-3347	1	CAPACITOR-FXD .01UF +100% 0% 25WVDC CER	28480	0160-3847
A8C6	0180-1746	1	CAPACITOR-FXD 150F+10% 20VDC TA	56289	150F156X9020R2
A8C7	0160-3847	1	CAPACITOR-FXD .01UF +100% 0% 25WVDC CER	28480	0160-3847
A8C8	0160-3847	1	CAPACITOR-FXD .01UF +100% 0% 25WVDC CER	28480	0160-3847
A8C9	0180-1746	1	CAPACITOR-FXD 150F+10% 20VDC TA	56289	150F156X9020R2
A8C10	0160-3847	1	CAPACITOR-FXD .01UF +100% 0% 25WVDC CER	28480	0160-3847
A8C11	0160-3347	1	CAPACITOR-FXD .01UF +100% 0% 25WVDC CER	28480	0160-3847
A8J1	1200-0424	1	SOCKET-IC 8LK 14 CONTACT	23890	CSA2900-14R
A8J2	1200-0424	1	SOCKET-IC 8LK 14 CONTACT	23890	CSA2900-14R
A8J3	1200-0424	1	SOCKET-IC 8LK 14 CONTACT	23890	CSA2900-14R
A8J4	1200-0423	1	SOCKET-IC 16-CONT DIP-PKG DIP-SLDR-TERMS	29480	1200-0423
A8L1	9100-1618	1	COIL-MLD 5.6UH 10% Q=45 .155DX.375LG	24226	157561
A8L2	9100-1618	1	COIL-MLD 5.6UH 10% Q=45 .155DX.375LG	24226	157561
A8L3	9100-1618	1	COIL-MLD 5.6UH 10% Q=45 .155DX.375LG	24226	157561
A8L4	9100-1618	1	COIL-MLD 5.6UH 10% Q=45 .155DX.375LG	24226	157561
A8AP1	4040-0751	2	EXTRACTOR-PC BD CRN POLYIC .062-40-THKNS	28480	4040-0751
A8AP2	4040-0751	1	EXTRACTOR-PC BD CRN POLYIC .062-40-THKNS	28480	4040-0751
A8R1	1810-0041	1	NETWORK-PES 9-PIN-SIP .15-PIN-SPCG	28480	1810-0041
A8R2	1810-0041	1	NETWORK-PES 9-PIN-SIP .15-PIN-SPCG	28480	1810-0041
A8R3	1810-0041	1	NETWORK-PES 9-PIN-SIP .15-PIN-SPCG	28480	1810-0041
A8R4	1810-0041	1	NETWORK-PES 9-PIN-SIP .15-PIN-SPCG	28480	1810-0041
A8R5	1810-0041	1	NETWORK-PES 9-PIN-SIP .15-PIN-SPCG	28480	1810-0041
A8R6	1810-0041	1	NETWORK-PES 9-PIN-SIP .15-PIN-SPCG	28480	1810-0041
A8R7	0684-4721	1	RESISTOR 4.7K 10% .25W FC TC=+400/+70C	01121	0684-4721
A8U1	1816-0140	1	IC 1K ROM TTL	28480	1816-0140
A8U2	1816-0139	1	IC 1K ROM TTL	28480	1816-0139
A8U3	1816-0133	1	IC 1K ROM TTL	28480	1816-0133
A8U4	1816-0134	1	IC 1K ROM TTL	28480	1816-0134
A8U5	1816-0132	1	IC 1K ROM TTL	28480	1816-0132
A8U6	1816-0136	1	IC 1K ROM TTL	28480	1816-0136
A8U7	1816-0137	1	IC 1K ROM TTL	28480	1816-0137
A8U8	1816-0130	1	IC 1K ROM TTL	28480	1816-0130
A8U9	1816-0131	1	IC 1K ROM TTL	28480	1816-0131
A8U10	1816-0141	1	IC 1K ROM TTL	28480	1816-0141

See introduction to this section for ordering information

Table 6-1. Replaceable Parts

Reference Designation	HP Part Number	Qty	Description	Mfr Code	Mfr Part Number
A8U11	1820-0138	1	IC 1K ROM TTL	28480	1816-0138
A8U12	1820-0077		IC-DIGITAL SN7476N TTL DUAL 0-TYPE	01295	SN7476N
A8U13	1820-0077		IC-DIGITAL SN7474N TTL DUAL 0-TYPE	01295	SN7474N
A8U14	1820-0839		IC-DIGITAL SN74175N TTL QUAD 0-TYPE	01295	SN74175N
A8U15	1820-0727	1	IC-DIGITAL 932100 TTL DUAL 2 2-TTL-LINE	07263	932100
A8U16	1820-0839		IC-DIGITAL SN74175N TTL QUAD 0-TYPE	01295	SN74175N
A8U17	1820-0953	2	IC-DIGITAL SN740152N TTL 5 DUAL *	01295	SN740152N
A8U18	1816-0135	1	IC 1K ROM TTL	28480	1816-0135
A8U19	1820-0214	3	IC-DIGITAL SN7442N TTL 4 BCD-TO-DEC	01295	SN7442N
A8U20	1820-0174		IC-DIGITAL SN7404N TTL HEX 1	01295	SN7404N
A8U21	1820-0361	1	IC-DIGITAL SN74H54N TTL H AND OF INV	01295	SN74H54N
A8U22	1820-0054		IC-DIGITAL SN7400N TTL QUAD 2 NAND	01295	SN7400N
A8U23	1820-0054		IC-DIGITAL SN7400N TTL QUAD 2 NAND	01295	SN7400N
A8U24	1820-0174		IC-DIGITAL SN7404N TTL HEX 1	01295	SN7404N
A8U25	1820-0214		IC-DIGITAL SN7442N TTL 4 BCD-TO-DEC	01295	SN7442N
A8U26	1820-0958		IC-DIGITAL SN745153N TTL 5 DUAL 4	01295	SN745153N
A8U27	1820-0301		IC-DIGITAL SN7475N TTL 0-TYPE	01295	SN7475N
A8U28	1820-0174		IC-DIGITAL SN7404N TTL HEX 1	01295	SN7404N
A8U29	1820-0174		IC-DIGITAL SN7404N TTL HEX 1	01295	SN7404N
A8U30	1820-0540	2	IC-DIGITAL SN74150N TTL 16 16-TTL-LINE	01295	SN74150N
A8U31	1820-0640		IC-DIGITAL SN74150N TTL 16 16-TTL-LINE	01295	SN74150N
A8U32	1820-0661	1	IC-DIGITAL SN7432N TTL QUAD 2 CR	01295	SN7432N
A8U33	1820-0539		IC-DIGITAL SN7457N TTL QUAD 2 NAND	01295	SN7457N
A8U34	1820-0214		IC-DIGITAL SN7442N TTL 4 BCD-TO-DEC	01295	SN7442N
A8U35	1820-0511		IC-DIGITAL SN7403N TTL QUAD 2 AND	01295	SN7403N
A8U36	1820-0544		IC-DIGITAL SN74H103N TTL H DUAL J-K	01295	SN74H103N
A8XU1	1200-0767		SOCKET-IC 16-CONT DIP-SOLDER-TERMS	91506	316-A650-3R
A8XU2	1200-0767		SOCKET-IC 16-CONT DIP-SOLDER-TERMS	91506	316-A650-3R
A8XU3	1200-0767		SOCKET-IC 16-CONT DIP-SOLDER-TERMS	91506	316-A650-3R
A8XU4	1200-0767		SOCKET-IC 16-CONT DIP-SOLDER-TERMS	91506	316-A650-3R
A8XU5	1200-0767		SOCKET-IC 16-CONT DIP-SOLDER-TERMS	91506	316-A650-3R
A8XU6	1200-0767		SOCKET-IC 16-CONT DIP-SOLDER-TERMS	91506	316-A650-3R
A8XU7	1200-0767		SOCKET-IC 16-CONT DIP-SOLDER-TERMS	91506	316-A650-3R
A8XU8	1200-0767		SOCKET-IC 16-CONT DIP-SOLDER-TERMS	91506	316-A650-3R
A8XU9	1200-0767		SOCKET-IC 16-CONT DIP-SOLDER-TERMS	91506	316-A650-3R
A8XU10	1200-0767		SOCKET-IC 16-CONT DIP-SOLDER-TERMS	91506	316-A650-3R
A8XU11	1200-0767		SOCKET-IC 16-CONT DIP-SOLDER-TERMS	91506	316-A650-3R
A8XU14	1200-0767		SOCKET-IC 16-CONT DIP-SOLDER-TERMS	91506	316-A650-3R
A8XU16	1200-0767		SOCKET-IC 16-CONT DIP-SOLDER-TERMS	91506	316-A650-3R
A8XU18	1200-0767		SOCKET-IC 16-CONT DIP-SOLDER-TERMS	91506	316-A650-3R
A9	03330-66510	3	PC ASSY: N4 COUNTER/SAMPLER	28480	03330-66510
A9C1	0180-0309	2	C:FXD ELECT 4.7 UF 20% 10VDCW	56289	1500475X0010A2-DYS
A9C2	0160-2009	6	C:FXD MICA 820 PF 5% 300VDCW	00853	RD15F821J3C
A9C3	0150-0093		C:FXD CER 0.01 UF +80-20% 100VDCW	72982	801-K800011
A9C4	0150-0093		C:FXD CER 0.01 UF +80-20% 100VDCW	72982	801-K800011
A9C5	0150-0093		C:FXD CER 0.01 UF +80-20% 100VDCW	72982	801-K800011
A9C6	0160-3671	2	C:FXD MY 0.033 UF 2% 200VDCW	72982	3560333-270
A9C7	0140-0214	6	C:FXD MICA 60 PF 5%	28480	0140-0214
A9C8	0180-1746	54	C:FXD ELECT 15 UF 10% 20VDCW	28480	0180-1746
A9C9	0180-1746		C:FXD ELECT 15 UF 10% 20VDCW	28480	0180-1746
A9C10	0160-0155	8	C:FXD MY 0.0033 UF 10% 200VDCW	56289	192P33292-PTS
A9C11	0170-0079	1	C:FXD 0.0047 UF 20% 5W	84411	601 PE
A9CR1	1901-0040	87	DIODE:SILICON 30MA 30WV	07263	FDG1088
A9CR2	1901-0040		DIODE:SILICON 30MA 30WV	07263	FDG1088
A9CR3	1901-0040		DIODE:SILICON 30MA 30WV	07263	FDG1088
A9CR4	1901-0040		DIODE:SILICON 30MA 30WV	07263	FDG1088

See introduction to this section for ordering information

Table 6-1. Replaceable Parts(Cont'd)

Reference Designation	HP Part Number	Qty	Description	Mfr Code	Mfr Part Number
A9CR5	1901-0040		DIODE: SILICON 30 MA 30 WV	07263	FDG1088
A9CR6, CR7	1902-3030		DIODE: BREAKDOWN 3.01V 5%	04713	SZ10939.32
A9IC1	1820-0282	3	IC:TTL QUAD 2-INPT EXCL. OR GATE	01295	SN7436M
A9IC2	1820-0782	4	IC:TTL TRIPLE 3-INPT NDR GATE	01295	SN7427N
A9IC3	1820-0751	10	IC:TTL PRESETTABLE DECADE COUNTER(50MHZ)	01295	SN74196N
A9IC4	1820-0751		IC:TTL PRESETTABLE DECADE COUNTER(50MHZ)	01295	SN74196N
A9IC5	1820-0076	2	IC:TTL DUAL J-K F/F W/PRESET CLKCK	01295	SN7476N
A9IC6	1820-0469	3	IC:DIGITAL TTL HI-SPEED F/F	01295	SN74H102N
A9IC7	1820-0715	2	IC:TTL DIGITAL HI-SPEED J-K F/F	01295	SN74H106N
A9IC8	1820-0656	2	IC:TTL SCHOTTKY TRIPLE 3-INPT AND GATE	01295	SN74S11N
A9IC9	1828-0043		INTEGRATED CIRCUIT: LINEAR	12040	SL12795
A9L1	9100-1634	1	COIL/CHOKE 75 UH 5%	28480	9100-1634
A9L2			NOT ASSIGNED		
A9L3	9100-1618	9	COIL:MOLDED CHOKE 5.60 UH	28480	9100-1618
A9L4	9140-0107	35	COIL:FXD RF 27 UH 10%	99800	1840-38
A9W1	1853-0020		TSTR:SI PNP	04713	SPS 3906
A9W2			NOT ASSIGNED		
A9U3	1854-0404	19	TSTR:SI NPN	28480	1854-0404
A9U4	1854-0354	8	TSTR:SI NPN	28480	1854-0354
A9U5	1854-0009	6	TSTR:SI NPN	80131	2N709
A9R1	0683-3325	14	R:FXD COMP 3300 OHM 5% 1/4W	01121	CB 3325
A9R2	0683-1525		R:FXD COMP 1500 OHM 5% 1/4W	01121	CB 1525
A9R3	0683-3223	1	R:FXD COMP 1.24 KOHM 5% 1/4W	75042	CEA T-0
A9R4	0583-1015	14	R:FXD COMP 100 OHM 5% 1/4W	01121	CB 1015
A9R5	0683-1055	3	R:FXD COMP 1 MEGOHM 5% 1/4W	01121	CB 1055
A9R6	0583-3025	8	R:FXD COMP 3000 OHM 5% 1/4W	01121	CB 3025
A9R7	0683-1235	2	R:FXD COMP 12K OHM 5% 1/4W	01121	CB 1235
A9R8	0583-1015		R:FXD COMP 100 OHM 5% 1/4W	01121	CB 1015
A9R9	0683-3315	7	R:FXD COMP 330 OHM 5% 1/4W	01121	CB 3315
A9R10	0683-1025		R:FXD COMP 1000 OHM 5% 1/4W	01121	CB 1025
A9R11	0683-2035	7	R:FXD COMP 20K OHM 5% 1/4W	01121	CB 2035
A9R12	0583-2035		R:FXD COMP 20K OHM 5% 1/4W	01121	CB 2035
A9R13	0683-1005	2	R:FXD COMP 10 OHM 5% 1/4W	01121	CB 1005
A9R14	0683-4715	20	R:FXD COMP 470 OHM 5% 1/4W	01121	CB 4715
A9R15	0683-3015	9	R:FXD COMP 300 OHM 5% 1/4W	01121	CB 3015
A9R16			NOT ASSIGNED		
A9R17	0683-1025		R:FXD COMP 1000 OHM 5% 1/4W	01121	CB 1025
A9R18			NOT ASSIGNED		
A9R19	0683-1025		R:FXD COMP 1000 OHM 5% 1/4W	01121	CB 1025
A9R20	0683-2025	30	R:FXD COMP 2000 OHM 5% 1/4W	01121	CB 2025
A9R21	0683-1015		R:FXD COMP 100 OHM 5% 1/4W	01121	CB 1015
A9SW1	3101-1341	7	SWITCH:SLIDE SPDT 0.5A 125V AC/DC	79727	C-111-0004
A9T1	9100-1398	1	PC ASSY:N4-VT0 BOARD	28480	03330-66509
A10	03330-66509	1		14655	RDML5F181J3C
A10C1	0140-0197	3	C:FXD MICA 180 PF 5% 300VDCW	72982	801-K800011
A10C2	0150-0093		C:FXD CER 0.01 UF +80-20% 100VDCW	28480	0140-0203
A10C3	0140-0203	9	C:FXD MICA 30 PF 5%	28480	0140-0203
A10C4	0140-0203		C:FXD MICA 30 PF 5%	28480	0140-0203
A10C5	0150-0093		C:FXD CER 0.01 UF +80-20% 100VDCW	72982	801-K800011
A10C6	0150-0093		C:FXD CER 0.01 UF +80-20% 100VDCW	72982	801-K800011
A10C7	0150-0093		C:FXD CER 0.01 UF +80-20% 100VDCW	72982	801-K800011
A10C8	0180-0291	15	C:FXD ELECT 1.0 UF 10% 35VDCW	56289	150D105X9035A2-DYS
A10C9	0180-1746		C:FXD ELECT 15 UF 10% 20VDCW	28480	0180-1746
A10C10	0180-1746		C:FXD ELECT 15 UF 10% 20VDCW	28480	0180-1746
A10C11	0150-0093		C:FXD CER 0.01 UF +80-20% 100VDCW	72982	801-K800011
A10CR1	1901-0040		DIODE:SILICON 30MA 30WV	07263	FDG1088
A10CR2	0122-0059	1	DIODE: VOLTAGE VAR	14430	T-048
A10CK3	1902-0025	10	DIODE,BREAKDOWN:10.0V 5% 400 MW	28480	1902-0025
A10IC1	1826-0043	32	IC:LINEAR OPERATIONAL AMPLIFIER	28480	1826-0043
A10IC2	1820-0751		IC:TTL PRESETTABLE DECADE COUNTER(50MHZ)	01295	SN74196N
A10L1	9100-3345	2	COIL:FXD 2 UH 5%	28480	9100-3345
A10L2	9140-0096	5	COIL/CHOKE 1.00 UH 10%	99800	1537-12
A10L3	9140-0210	17	COIL/CHOKE 100 UH 5%	82142	15-1315-12J
A10L4	9100-1618		COIL:MOLDED CHOKE 5.60 UH	28480	9100-1618
A10L5	9140-0107		COIL:FXD RF 27 UH 10%	99800	1840-38
A10W1	1853-0020	36	TSTR:SI PNP(SELECTED FROM 2N3702)	28480	1853-0020
A10W2	1853-0020		TSTR:SI PNP(SELECTED FROM 2N3702)	28480	1853-0020
A10U3	1853-0020		TSTR:SI PNP(SELECTED FROM 2N3702)	28480	1853-0020
A10U4	1853-0020		TSTR:SI PNP(SELECTED FROM 2N3702)	28480	1853-0020
A10U5	1853-0020		TSTR:SI PNP(SELECTED FROM 2N3702)	28480	1853-0020
A10U6	1853-0020		TSTR:SI PNP(SELECTED FROM 2N3702)	28480	1853-0020
A10U7	1854-0345	26	TSTR:SI NPN	80131	2N5179
A10U8	1854-0345		TSTR:SI NPN	80131	2N5179
A10U9	1854-0019	40	TSTR:SI NPN	28480	1854-0019
A10U10	1854-0019		TSTR:SI NPN	28480	1854-0019
A10U11	1854-0009		TSTR:SI NPN	80131	2N709
A10K1	1810-0074	3	RESISTIVE NETWORK:20 PIN	28480	1810-0074

See introduction to this section for ordering information

Table 6-1. Replaceable Parts(Cont'd)

Reference Designation	HP Part Number	Qty	Description	Mfr Code	Mfr Part Number
A10R2	0757-0446	5	R:FXD MET FLM 15.0K OHM 1% 1/8W	28480	0757-0446
A10R3	0757-0463	3	R:FXD MET FLM 32.5K OHM 1% 1/8W	28480	0757-0463
A10R4	0757-0446		R:FXD MET FLM 15.0K OHM 1% 1/8W	28480	0757-0446
A10R5	0757-0453	6	R:FXD MET FLM 30.1K OHM 1% 1/8W	28480	0757-0453
A10R6	0757-0453		R:FXD MET FLM 30.1K OHM 1% 1/8W	28480	0757-0453
A10R7	0698-3572	4	R:FXD FLM 60.4K OHM 1% 1/8W	28480	0698-3572
A10R8	0698-3572		R:FXD FLM 60.4K OHM 1% 1/8W	28480	0698-3572
A10R9	0683-1245	2	R:FXD COMP 120K OHM 5% 1/4W	01121	CB 1245
A10K10	0683-1245		R:FXD COMP 120K OHM 5% 1/4W	01121	CB 1245
A10K11	0683-1545	2	R:FXD COMP 150K OHM 5% 1/4W	01121	CB 1545
A10K12	0683-1545		R:FXD COMP 150K OHM 5% 1/4W	01121	CB 1545
A10R13	0683-3045	2	R:FXD COMP 300K OHM 5% 1/4W	01121	CB 3045
A10K14	0683-3045		R:FXD COMP 300K OHM 5% 1/4W	01121	CB 3045
A10K15	0757-0442	25	R:FXD MET FLM 10.0K OHM 1% 1/8W	28480	0757-0442
A10K16	0757-0442		R:FXD MET FLM 10.0K OHM 1% 1/8W	28480	0757-0442
A10K17	2100-2489	4	R:VAR FLM 5K OHM 10% LIN 1/2W	28480	2100-2489
A10K18	0683-1035	2	R:FXD 10K OHM .05% 1/4W	01121	CB 1035
A10R19	0683-1535	8	R:FXD COMP 15K OHM 5% 1/4W	01121	CB 1535
A10K20	0683-5105	5	R:FXD COMP 51 OHM 5% 1/4W	01121	CB 5105
A10R21	0683-4735		R:FXD COMP 47K OHM 5% 1/4W	01121	CB 4735
A10R22	0683-2025		R:FXD COMP 2000 OHM 5% 1/4W	01121	CB 2025
A10R23	0683-6225	4	R:FXD COMP 6200 OHM 5% 1/4W	01121	CB 6225
A10R24	0683-5105		R:FXD COMP 51 OHM 5% 1/4W	01121	CB 5105
A10R25	0683-5115	2	R:FXD COMP 510 OHM 5% 1/4W	01121	CB 5115
A10R26	0683-3025		R:FXD COMP 3000 OHM 5% 1/4W	01121	CB 3025
A10R27	0683-1225	2	R:FXD COMP 1200 OHM 5% 1/4W	01121	CB 1225
A10R28	0683-5105		R:FXD COMP 51 OHM 5% 1/4W	01121	CB 5105
A10K29	0683-2015	10	R:FXD COMP 200 OHM 5% 1/4W	01121	CB 2015
A10K30	0683-5105		R:FXD COMP 51 OHM 5% 1/4W	01121	CB 5105
A10R31	0683-1215	1	R:FXD COMP 120 OHM 5% 1/4W	01121	CB 1215
A10R32	0683-1035		R:FXD 10K OHM .05% 1/4W	01121	CB 1035
A10R33	0683-2025		R:FXD COMP 2000 OHM 5% 1/4W	01121	CB 2025
A10K34	0683-1535		R:FXD COMP 15K OHM 5% 1/4W	01121	CB 1535
A10K35	0698-3279	18	R:FXD MET FLM 4990 OHM 1% 1/8W	28480	0698-3279
A10R36	0683-2025		R:FXD COMP 2000 OHM 5% 1/4W	01121	CB 2025
A10K37	0683-4735		R:FXD COMP 47K OHM 5% 1/4W	01121	CB 4735
A10SW1	3101-1341		SWITCH:SLIDE SPDT 0.5A 125V AC/DC	79727	C-111-0004
A11	03330-66510		PC ASSY: N3 COUNTER/SAMPLER (IDENTICAL TO A9)	28480	03330-66510
A12	03330-66511	2	PC ASSY:N3 VTD BOARD	28480	03330-66511
A12C1	0140-0197		C:FXD MICA 180 PF 5% 300VDCW	14655	RDML5F181J3C
A12C2	0150-0093		C:FXD CER 0.01 UF +80-20% 100VDCW	72982	801-K800011
A12C3	0140-0203		C:FXD MICA 30 PF 5%	28480	0140-0203
A12C4	0140-0203		C:FXD MICA 30 PF 5%	28480	0140-0203
A12C5			NOT ASSIGNED		
A12C6	0150-0093		C:FXD CER 0.01 UF +80-20% 100VDCW	72982	801-K800011
A12C7	0150-0093		C:FXD CER 0.01 UF +80-20% 100VDCW	72982	801-K800011
A12C8	0150-0093		C:FXD CER 0.01 UF +80-20% 100VDCW	72982	801-K800011
A12C9	0150-0093		C:FXD CER 0.01 UF +80-20% 100VDCW	72982	801-K800011
A12C10	0150-0093		C:FXD CER 0.01 UF +80-20% 100VDCW	72982	801-K800011
A12C11	0150-0093		C:FXD CER 0.01 UF +80-20% 100VDCW	72982	801-K800011
A12C12	0150-0093		C:FXD CER 0.01 UF +80-20% 100VDCW	72982	801-K800011
A12C13	0150-0093		C:FXD CER 0.01 UF +80-20% 100VDCW	72982	801-K800011
A12C14	0180-0291		C:FXD ELECT 1.0 UF 10% 35VDCW	56289	1500105X9035A2-DYS
A12C15	0180-1746		C:FXD ELECT 15 UF 10% 20VDCW	28480	0180-1746
A12C16	0180-1746		C:FXD ELECT 15 UF 10% 20VDCW	28480	0180-1746
A12C17	0180-0291		C:FXD ELECT 1.0 UF 10% 35VDCW	56289	1500105X9035A2-DYS
A12C18	0150-0093		C:FXD CER 0.01 UF +80-20% 100VDCW	72982	801-K800011
A12CR1	1901-0040		DIODE:SILICON 30MA 30WV	07263	FDG1088
A12CR2	0122-0059	1	DIODE: VOLTAGE VAR	14430	T-048 0BD
A12CR3	1902-0025		DIODE,BREAKDOWN:10.0V 5% 400 MW	28480	1902-0025
A12IC1	1826-0043		IC:LINEAR OPERATIONAL AMPLIFIER	28480	1826-0043
A12IC2	1826-0043		IC:LINEAR OPERATIONAL AMPLIFIER	28480	1826-0043
A12L1	9100-3345		COIL:FXD 2 UH 5%	28480	9100-3345
A12L2	9140-0096		COIL/CHOKE 1.00 UH 10%	99800	1537-12
A12L3	9140-0210		COIL/CHOKE 100 UH 5%	82142	15-1315-12J
A12L4	9140-0210		COIL/CHOKE 100 UH 5%	82142	15-1315-12J
A12L5	9140-0107		COIL:FXD RF 27 UH 10%	99800	1840-38
A12L6	9140-0210		COIL/CHOKE 100 UH 5%	82142	15-1315-12J
A12Q1	1853-0020		TSTR:SI PNP(SELECTED FROM 2N3702)	28480	1853-0020
A12Q2	1853-0020		TSTR:SI PNP(SELECTED FROM 2N3702)	28480	1853-0020
A12Q3	1853-0020		TSTR:SI PNP(SELECTED FROM 2N3702)	28480	1853-0020
A12Q4	1853-0020		TSTR:SI PNP(SELECTED FROM 2N3702)	28480	1853-0020
A12Q5	1853-0020		TSTR:SI PNP(SELECTED FROM 2N3702)	28480	1853-0020
A12Q6	1853-0020		TSTR:SI PNP(SELECTED FROM 2N3702)	28480	1853-0020

See introduction to this section for ordering information

Table 6-1. Replaceable Parts(Cont'd)

Reference Designation	HP Part Number	Qty	Description	Mfr Code	Mfr Part Number
A12Q7	1853-0020		TSTR:SI PNP(SELECTED FROM 2N3702)	28480	1853-0020
A12Q8	1853-0020		TSTR:SI PNP(SELECTED FROM 2N3702)	28480	1853-0020
A12Q9	1854-0345		TSTR:SI NPN	80131	2N5179
A12Q10	1854-0345		TSTR:SI NPN	80131	2N5179
A12Q11	1854-0019		TSTR:SI NPN	28480	1854-0019
A12Q12	1854-0019		TSTR:SI NPN	28480	1854-0019
A12Q13	1854-0019		TSTR:SI NPN	28480	1854-0019
A12Q14	1854-0019		TSTR:SI NPN	28480	1854-0019
A12Q15	1854-0019		TSTR:SI NPN	28480	1854-0019
A12R1	1810-0074		RESISTIVE NETWORK:20 PIN	28480	1810-0074
A12R2	1810-0073	2	RESISTIVE NETWORK:12 PIN	28480	1810-0073
A12R3	0698-3279		R:FXD MET FLM 4990 OHM 1% 1/8W	28480	0698-3279
A12R4	0757-0442	1	R:FXD MET FLM 10K OHM 1% 1/8W	24546	C4-1/8-TO-1002-F
A12R5	0683-1055		R:FXD COMP 1 MEGOHM 5% 1/4W	01121	CB 1055
A12R6	0698-4479	3	R:FXD FLM 14K OHM 1% 1/8W	28480	0698-4479
A12R7 *	0698-4474		R:FXD MET FLM 8.45K OHM 1% 1/8W	24546	C4-1/8-TO-8451-F
A12R8	2100-2489		R:VAR FLM 5K OHM 10% LIN 1/2W	28480	2100-2489
A12R9	0698-3279		R:FXD MET FLM 4990 OHM 1% 1/8W	28480	0698-3279
A12R10	0683-1035		R:FXD COMP 10K OHM 5% 1/4W	01121	CB 1035
A12R11	0683-1535		R:FXD COMP 15K OHM 5% 1/4W	01121	CB 1535
A12R12	0683-4705	39	R:FXD COMP 47 OHM 5% 1/4W	01121	CB 4705
A12R13	0683-4735		R:FXD COMP 47K OHM 5% 1/4W	01121	CB 4735
A12R14	0683-2025		R:FXD COMP 2000 OHM 5% 1/4W	01121	CB 2025
A12R15	0683-1535		R:FXD COMP 15K OHM 5% 1/4W	01121	CB 1535
A12R16	0683-4705		R:FXD COMP 47 OHM 5% 1/4W	01121	CB 4705
A12R17	0683-6225		R:FXD COMP 6200 OHM 5% 1/4W	01121	CB 6225
A12R18	0683-4715		R:FXD COMP 470 OHM 5% 1/4W	01121	CB 4715
A12R19	0683-4725	46	R:FXD COMP 4700 OHM 5% 1/4W	01121	CB 4725
A12R20	0683-4705		R:FXD COMP 47 OHM 5% 1/4W	01121	CB 4705
A12R21	0683-4715		R:FXD COMP 470 OHM 5% 1/4W	01121	CB 4715
A12R22	0683-4725		R:FXD COMP 4700 OHM 5% 1/4W	01121	CB 4725
A12R23	0683-1015		R:FXD COMP 100 OHM 5% 1/4W	01121	CB 1015
A12R24	0683-4725		R:FXD COMP 4700 OHM 5% 1/4W	01121	CB 4725
A12R25	0683-4705		R:FXD COMP 47 OHM 5% 1/4W	01121	CB 4705
A12R26	0683-6815	6	R:FXD COMP 680 OHM 5% 1/4W	01121	CB 6815
A12R27	0683-4725		R:FXD COMP 4700 OHM 5% 1/4W	01121	CB 4725
A12R28	0683-4735		R:FXD COMP 47 OHM 5% 1/4W	01121	CB 4705
A12R29	0683-4725		R:FXD COMP 4700 OHM 5% 1/4W	01121	CB 4725
A12R30	0683-1015		R:FXD COMP 100 OHM 5% 1/4W	01121	CB 1015
A12R31	0683-4725		R:FXD COMP 4700 OHM 5% 1/4W	01121	CB 4725
A12R32	0683-4715		R:FXD COMP 470 OHM 5% 1/4W	01121	CB 4715
A12R33	0683-4705		R:FXD COMP 47 OHM 5% 1/4W	01121	CB 4705
A12R34	0683-6815		R:FXD COMP 680 OHM 5% 1/4W	01121	CB 6815
A12R35	0683-4735		R:FXD COMP 47K OHM 5% 1/4W	01121	CB 4735
A13	03330-66510		PC ASSY: N2 COUNTER/SAMPLER (IDENTICAL TO A9)	28480	03330-66510
A14	03330-66511		PC ASSY: N2 VTO (IDENTICAL to A12)	28480	03330-66511
A15	03330-66513	1	PC ASSY:NI C/S 80ARD	28480	03330-66513
A15C1	0170-0079	7	C:FXD MY 0.047UF 20% 50VDCW	84411	STYLE 3 TYPE 601PE
A15C2	0160-0155		C:FXD MY 0.0033 UF 10% 200VDCW	56289	192P33292-PTS
A15C3	0180-0291		C:FXD ELECT 1.0 UF 10% 35VDCW	56289	1500105X9035A2-DYS
A15C4	0160-2009		C:FXD MICA 820 PF 5% 300VDCW	00853	RD15F821J3C
A15C5	0150-0093		C:FXD CER 0.01 UF +80-20% 100VDCW	72982	801-K800011
A15C6	0150-0093		C:FXD CER 0.01 UF +80-20% 100VDCW	72982	801-K800011
A15C7	0140-0198	9	C:FXD MICA 200 PF 5%	72136	RD15F201J3C
A15C8	0140-0214		C:FXD MICA 60 PF 5%	28480	0140-0214
A15C9	0150-0093		C:FXD CER 0.01 UF +80-20% 100VDCW	72982	801-K800011
A15C10	0160-3671		C:FXD MY 0.033 UF 2% 200VDCW	72982	356C333-270
A15C11	0160-3622	5	C:FXD CER 0.1 UF +80-20% 100VDCW	72982	8131-100-651-104Z
A15C12	0160-2204	4	C:FXD MICA 100PF 5%	72136	RD15F101J3C
A15C13	0180-1746		C:FXD ELECT 15 UF 10% 20VDCW	28480	0180-1746
A15C14	0180-1746		C:FXD ELECT 15 UF 10% 20VDCW	28480	0180-1746
A15C15	0180-1746		C:FXD ELECT 15 UF 10% 20VDCW	28480	0180-1746
A15C16	0180-1746		C:FXD ELECT 15 UF 10% 20VDCW	28480	0180-1746
A15C17	0140-0214		C:FXD MICA 60 PF 5%	28480	0140-0214
A15C18	0160-3622		C:FXD CER 0.1 UF +80-20% 100VDCW	72982	8131-100-651-104Z
A15C19	0160-3622		C:FXD CER 0.1 UF +80-20% 100VDCW	72982	8131-100-651-104Z
A15C20	0160-0155		C:FXD MY 0.0033 UF 10% 200VDCW	56289	192P33292-PTS
A15CR1	1902-3002	2	DIODE BREAKDOWN: 237 V 5% 400 MW	28480	1902-3002
A15CR2	1902-3002		DIODE BREAKDOWN: 237 V 5% 400 MW	28480	1902-3002
A15CR3	1901-0040		DIODE:SILICON 30MA 30WV	07263	FDG1088
A15CR4	1901-0040		DIODE:SILICON 30MA 30WV	07263	FDG1088
A15CR5	1901-0040		DIODE:SILICON 30MA 30WV	07263	FDG1088
A15CR6	1901-0040		DIODE:SILICON 30MA 30WV	07263	FDG1088
A15CR7			NOT ASSIGNED		
A15CR8	1901-0040		DIODE:SILICON 30MA 30WV	07263	FDG1088

See introduction to this section for ordering information

Table 6-1. Replaceable Parts(Cont'd)

Reference Designation	HP Part Number	Qty	Description	Mfr Code	Mfr Part Number
A15CR9	1901-0040	4	DIGDE:SILICON 30MA 30WV	07263	FDG1088
A15CR10	1902-0623		DIGDE:ZENER	28480	1902-0623
A15IC1	1820-0282		IC:TTL QUAD 2-INPT EXCL. OR GATE	01295	SN7486M
A15IC2	1820-0782		IC:TTL TRIPLE 3-INPT NOR GATE	01295	SN7427N
A15IC3	1820-0751		IC:TTL PRESETTABLE DECADE COUNTER(50MHZ	01295	SN74196N
A15IC4	1820-0751	3	IC:TTL PRESETTABLE DECADE COUNTER(50MHZ	01295	SN74196N
A15IC5	1820-0076		IC:TTL DUAL J-K F/F W/PRESET CLOCK	01295	SN7476N
A15IC6	1820-0686		IC:TTL SCHOTTKY TRIPLE 3-INPT AND GATE	01295	SN74511N
A15IC7	1820-0370		IC:TTL HS QUAD 2-INPT NAND GATE	01295	SN74H00N
A15IC8	1820-0715		IC:TTL DIGITAL HI-SPEED J-K F/F	01295	SN74H106N
A15IC9	1820-0469	1	IC:DIGITAL TTL HI-SPEED F/F	01295	SN74H102N
A15IC10	1820-0370		IC:TTL HS QUAD 2-INPT NAND GATE	01295	SN74H00N
A15L1	9140-0031		COIL:FXD RF 75 UHY	28480	9140-0031
A15L2			NOT ASSIGNED		
A15L3			NOT ASSIGNED		
A15L4	9140-0210	3	COIL/CHOKE 100 UH 5%	82142	15-1315-12J
A15L5	9100-1618		COIL:MOLDED CHOKE 5.60 UH	28480	9100-1618
A15L6	9140-0137		COIL:FXD RF 1000 UH 5%	28480	9140-0137
A15L7	9140-0210		COIL/CHOKE 100 UH 5%	82142	15-1315-12J
A15Q1	1853-0086		TSTR: SI PNP	04713	SPS-3322
A15Q2	1853-0086	3	TSTR: SI PNP	04713	SPS-3322
A15Q3	1853-0086		TSTR: SI PNP	04713	SPS-3322
A15Q4	1854-0226		TSTR:SI NPN	80131	2N4384
A15Q5	1854-0404		TSTR:SI NPN	28480	1854-0404
A15Q6	1854-0354		TSTR:SI NPN	28480	1854-0354
A15Q7	1854-0404	16	TSTR:SI NPN	28480	1854-0404
A15Q8	1853-0203		TSTR:SI PNP	28480	1853-0203
A15Q9	1854-0009		TSTR:SI NPN	80131	2N709
A15Q10			NOT ASSIGNED		
A15Q11	1854-0226		TSTR:SI NPN	80131	2N4384
A15R1	0757-0273	3	R:FXD MET FLM 3.01K OHM 1% 1/8W	28480	0757-0273
A15R2	0698-3223		R:FXD FLM 1.24K OHM 1% 1/8W	28480	0698-3223
A15R3	0757-0486		R:FXD MET FLM 750K OHM 1% 1/8W	28480	0757-0486
A15R4	0698-4482		R:FXD FLM 17.4K OHM 1% 1/8W	28480	0698-4482
A15R5	0757-0486		R:FXD MET FLM 750K OHM 1% 1/8W	28480	0757-0486
A15R6	0757-0462	1	R:FXD MET FLM 75.0K OHM 1% 1/8W	28480	0757-0462
A15R7	0757-0410		R:FXD MET FLM 301 OHM 1% 1/8W	28480	0757-0410
A15R8	0757-0486		R:FXD MET FLM 750K OHM 1% 1/8W	28480	0757-0486
A15R9			NOT ASSIGNED		
A15R10			NOT ASSIGNED		
A15R11	0757-0273	2	R:FXD MET FLM 3.01K OHM 1% 1/8W	28480	0757-0273
A15R12	0757-0282		R:FXD MET FLM 221 OHM 1% 1/8W	28480	0757-0282
A15R13	0757-0444		R:FXD MET FLM 12.1K OHM 1% 1/8W	28480	0757-0444
A15R14	0757-0282		R:FXD MET FLM 221 OHM 1% 1/8W	28480	0757-0282
A15R15	0698-3279		R:FXD MET FLM 4990 OHM 1% 1/8W	28480	0698-3279
A15R16	0757-0449	7	R:FXD FLM 20K OHM 1% 1/8W	28480	0757-0449
A15R17	0757-0449		R:FXD FLM 20K OHM 1% 1/8W	28480	0757-0449
A15R18	0683-1025		R:FXD COMP 1000 OHM 5% 1/4W	01121	CB 1025
A15R19	0683-0475		R:FXD COMP 4.7 OHM 5% 1/4W	01121	CB 47G5
A15R20			NOT ASSIGNED		
A15R21	0683-3015	1	R:FXD COMP 300 OHM 5% 1/4W	01121	CB 3015
A15R22	0683-3015		R:FXD COMP 300 OHM 5% 1/4W	01121	CB 3015
A15R23	0683-1025		R:FXD COMP 1000 OHM 5% 1/4W	01121	CB 1025
A15R24	0683-2025		R:FXD COMP 2000 OHM 5% 1/4W	01121	CB 2025
A15R25	0683-2025		R:FXD COMP 2000 OHM 5% 1/4W	01121	CB 2025
A15R26	0683-2025	1	R:FXD COMP 2000 OHM 5% 1/4W	01121	CB 2025
A15R27	0683-2025		R:FXD COMP 2000 OHM 5% 1/4W	01121	CB 2025
A15R28	0683-2025		R:FXD COMP 2000 OHM 5% 1/4W	01121	CB 2025
A15R29	0683-2025		R:FXD COMP 2000 OHM 5% 1/4W	01121	CB 2025
A15R30	0683-4715		R:FXD COMP 470 OHM 5% 1/4W	01121	CB 4715
A15R31	0683-2025	1	R:FXD COMP 2000 OHM 5% 1/4W	01121	CB 2025
A15R32	0686-3915		R:FXD COMP 390 OHM 5% 1/2W	01121	EB 3915
A15R33	0757-0442		R:FXD MET FLM 10.0K OHM 1% 1/8W	28480	0757-0442
A15T1	9100-1393		TRANSFORMER:TDRDID	28480	9100-1393
A16	03330-66512		1	PC ASSY:NI-VTD BOARD	28480
A16C1	0180-1735	C:FXD ELECT 0.22 UF 10% 35VDCW		28480	0180-1735
A16C2	0140-0172	C:FXD MICA 3000 PF 1% 100VDCW		28480	0140-0172
A16C3	0140-0172	C:FXD MICA 3000 PF 1% 100VDCW		28480	0140-0172
A16C4	0140-0172	C:FXD MICA 3000 PF 1% 100VDCW		28480	0140-0172
A16C5	0140-0172	3	C:FXD MICA 3000 PF 1% 100VDCW	28480	0140-0172
A16C6	0140-0200		C:FXD MICA 390 PF 5%	72136	RD015F391-J3C
A16C7	0150-0122		C:FXD CER 2000 PF 20% 500VDCW	72982	901-000-Y55-202M
A16C8	0150-0093		C:FXD CER 0.01 UF +80-20% 100VDCW	72982	801-K800011
A16C9	0140-0203		C:FXD MICA 30 PF 5%	28480	0140-0203

See introduction to this section for ordering information

Table 6-1. Replaceable Parts(Cont'd)

Reference Designation	HP Part Number	Qty	Description	Mfr Code	Mfr Part Number
A16C10	0140-0203		C:FXD MICA 30 PF 5%	28480	0140-0203
A16C11			NOT ASSIGNED		
A16C12	0150-0093		C:FXD CER 0.01 UF +80-20% 100VDCW	72982	801-K800011
A16C13	0150-0093		C:FXD CER 0.01 UF +80-20% 100VDCW	72982	801-K800011
A16C14	0150-0093		C:FXD CER 0.01 UF +80-20% 100VDCW	72982	801-K800011
A16C15	0150-0093		C:FXD CER 0.01 UF +80-20% 100VDCW	72982	801-K800011
A16C16	0150-0093		C:FXD CER 0.01 UF +80-20% 100VDCW	72982	801-K800011
A16C17	0150-0093		C:FXD CER 0.01 UF +80-20% 100VDCW	72982	801-K800011
A16C18	0150-0093		C:FXD CER 0.01 UF +80-20% 100VDCW	72982	801-K800011
A16C19	0150-0093		C:FXD CER 0.01 UF +80-20% 100VDCW	72982	801-K800011
A16C20	0180-0291		C:FXD ELECT 1.0 UF 10% 35VDCW	56289	150D105X9035A2-DYS
A16C21	0180-1746		C:FXD ELECT 15 UF 10% 20VDCW	28480	0180-1746
A16C22	0180-1746		C:FXD ELECT 15 UF 10% 20VDCW	28480	0180-1746
A16C23	0180-0291		C:FXD ELECT 1.0 UF 10% 35VDCW	56289	150D105X9035A2-DYS
A16C24	0150-0093		C:FXD CER 0.01 UF +80-20% 100VDCW	72982	801-K800011
A16CK1	1901-0040		DIODE:SILICON 30MA 30WV	07263	FDG1088
A16CK2			NOT ASSIGNED		
A16CK3			NOT ASSIGNED		
A16CK4			NOT ASSIGNED		
A16CK5	0122-0059	6	DIODE:VOLTAGE VARIABLE CAPACITANCE	28480	0122-0059
A16CK6	0122-0059		DIODE:VOLTAGE VARIABLE CAPACITANCE	28480	0122-0059
A16CR7	1902-0025		DIODE,BREAKDOWN:10.0V 5% 400 MW	28480	1902-0025
A16IC1	1826-0043		IC:LINEAR OPERATIONAL AMPLIFIER	28480	1826-0043
A16IC2	1826-0043		IC:LINEAR OPERATIONAL AMPLIFIER	28480	1826-0043
A16LI	9100-3312	3	INDUCTOR:VAR 1.00 UH 10%	28480	9100-3312
A16L2	9140-0096		COIL/CHOKE 1.00 UH 10%	99800	1537-12
A16L3	9140-0210		COIL/CHOKE 100 UH 5%	82142	15-1315-12J
A16L4	9140-0210		COIL/CHOKE 100 UH 5%	82142	15-1315-12J
A16L5	9140-0107	1	COIL:FXD RF 27 UH 10%	99800	1840-38
A16L6	9140-0210		COIL/CHCKE 100 UH 5%	82142	15-1315-12J
A16Q1	1853-0020		TSTR:SI PNP(SELECTED FROM 2N3702)	28480	1853-0020
A16Q2	1853-0020		TSTR:SI PNP(SELECTED FROM 2N3702)	28480	1853-0020
A16Q3	1853-0020		TSTR:SI PNP(SELECTED FROM 2N3702)	28480	1853-0020
A16Q4	1853-0020		TSTR:SI PNP(SELECTED FROM 2N3702)	28480	1853-0020
A16Q5	1853-0020		TSTR:SI PNP(SELECTED FROM 2N3702)	28480	1853-0020
A16Q6	1853-0020		TSTR:SI PNP(SELECTED FROM 2N3702)	28480	1853-0020
A16Q7	1853-0020		TSTR:SI PNP(SELECTED FROM 2N3702)	28480	1853-0020
A16Q8	1853-0020		TSTR:SI PNP(SELECTED FROM 2N3702)	28480	1853-0020
A16Q9	1853-0020		TSTR:SI PNP(SELECTED FROM 2N3702)	28480	1853-0020
A16Q10	1853-0086		TSTR:SI PNP	80131	2N5087
A16Q11	1855-0081	7	TSTR:SI FET	80131	2N5245
A16Q12	1854-0354		TSTR:SI NPN	28480	1854-0354
A16Q13	1853-0010	17	TSTR:SI PNP(SELECTED FROM 2N3251)	28480	1853-0010
A16Q14			NOT ASSIGNED		
A16Q15	1854-0345		TSTR:SI NPN	80131	2N5179
A16Q16	1854-0345		TSTR:SI NPN	80131	2N5179
A16Q17	1854-0019		TSTR:SI NPN	28480	1854-0019
A16Q18	1854-0019		TSTR:SI NPN	28480	1854-0019
A16Q19	1854-0019		TSTR:SI NPN	28480	1854-0019
A16Q20	1854-0019		TSTR:SI NPN	28480	1854-0019
A16Q21	1854-0019		TSTR:SI NPN	28480	1854-0019
A16R1	1810-0074		RESISTIVE NETWORK:20 PIN	28480	1810-0074
A16R2	1810-0073		RESISTIVE NETWORK:12 PIN	28480	1810-0073
A16R3	0698-3279		R:FXD MET FLM 4990 OHM 1% 1/8W	28480	0698-3279
A16R4	0757-0446		R:FXD MET FLM 15.0K OHM 1% 1/8W	28480	0757-0446
A16R5	0683-6835	2	R:FXD COMP 68K OHM 5% 1/4W	01121	CB 6835
A16R6	0698-3279		R:FXD MET FLM 4990 OHM 1% 1/8W	28480	0698-3279
A16R7	0698-0064	1	R:FXD MET FLM 9.31K OHM 1% 1/8W	28480	0698-0064
A16R8	0683-2025		R:FXD COMP 2000 OHM 5% 1/4W	01121	CB 2025
A16R9	0683-2735	3	R:FXD COMP 27K OHM 5% 1/4W	01121	CB 2735
A16R10	0683-2235	1	R:FXD COMP 22K OHM 5% 1/4W	01121	CB 2235
A16R11	2100-2489		R:VAR FLM 5K OHM 10% LIN 1/2W	28480	2100-2489
A16R12	0683-1015		R:FXD COMP 100 OHM 5% 1/4W	01121	CB 1015
A16R13	0757-0469	7	R:FXD MET FLM 150 K OHM 1% 1/8W	28480	0757-0469
A16R14	0757-0280	32	R:FXD MET FLM 1K OHM 1% 1/8W	28480	0757-0280
A16R15	0683-1015		R:FXD COMP 100 OHM 5% 1/4W	01121	CB 1015
A16R16			NOT ASSIGNED		
A16R17			NOT ASSIGNED		
A16R18	0698-3438	1	R:FXD MET FLM 147 OHM 1% 1/8W	28480	0698-3438
A16R19	0698-4448	2	R:FXD FLM 294 OHM 1% 1/8W	28480	0698-4448
A16R20	0698-4448		R:FXD FLM 294 OHM 1% 1/8W	28480	0698-4448
A16R21	0757-0280		R:FXD MET FLM 1K OHM 1% 1/8W	28480	0757-0280
A16R22	0683-1535		R:FXD COMP 15K OHM 5% 1/4W	01121	CB 1535
A16R23	0683-4705		R:FXD COMP 47 OHM 5% 1/4W	01121	CB 4705
A16R24	0683-6835		R:FXD COMP 68K OHM 5% 1/4W	01121	CB 6835

See introduction to this section for ordering information

Table 6-1. Replaceable Parts(Cont'd)

Reference Designation	HP Part Number	Qty	Description	Mfr Code	Mfr Part Number
A16R25	0683-2025		R:FXD COMP 2000 OHM 5% 1/4W	01121	CB 2025
A16R26	0683-4705		R:FXD COMP 47 OHM 5% 1/4W	01121	CB 4705
A16R27	0683-1235		R:FXD COMP 12K OHM 5% 1/4W	01121	CB 1235
A16R28	0683-2435		R:FXD COMP 24K OHM 5% 1/4W	01121	CB 2435
A16R29	0583-4715	1	R:FXD COMP 470 OHM 5% 1/4W	01121	CB 4715
A16R30	0683-4705		R:FXD COMP 47 OHM 5% 1/4W	01121	CB 4705
A16K31	0683-4715		R:FXD COMP 470 OHM 5% 1/4W	01121	CB 4715
A16K32	0683-4725		R:FXD COMP 4700 OHM 5% 1/4W	01121	CB 4725
A16R33	0583-1015		R:FXD COMP 100 OHM 5% 1/4W	01121	CB 1015
A16R34	0683-4725		R:FXD COMP 4700 OHM 5% 1/4W	01121	CB 4725
A16R35	0583-2705	1	R:FXD COMP 27 OHM 5% 1/4W	01121	CB 2705
A16K36	0683-6815		R:FXD COMP 680 OHM 5% 1/4W	01121	CB 6815
A16K37	0583-4715		R:FXD COMP 470 OHM 5% 1/4W	01121	CB 4715
A16R38	0683-4705		R:FXD COMP 47 OHM 5% 1/4W	01121	CB 4705
A16R39	0683-4725		R:FXD COMP 4700 OHM 5% 1/4W	01121	CB 4725
A16R4J	0683-4725		R:FXD COMP 4700 OHM 5% 1/4W	01121	CB 4725
A16R41	0683-4725		R:FXD COMP 4700 OHM 5% 1/4W	01121	CB 4725
A16R42	0683-1015		R:FXD COMP 100 OHM 5% 1/4W	01121	CB 1015
A16R43	0583-4725		R:FXD COMP 4700 OHM 5% 1/4W	01121	CB 4725
A16R44	0683-4705		R:FXD COMP 47 OHM 5% 1/4W	01121	CB 4705
A16R45	0683-6815		R:FXD COMP 680 OHM 5% 1/4W	01121	CB 6815
A16R46	0583-4735		R:FXD COMP 47K OHM 5% 1/4W	01121	CB 4735
A16K47	0757-0280		R:FXD MET FLM 1K OHM 1% 1/8W	28480	0757-0280
A17	03330-66514	1	PC ASSY:20MHZ BOARD	29480	03330-66514
A17C1	0150-0122		C:FXD CER 2000 PF 20% 500VDCW	72982	801-000-Y55-202M
A17C2	0180-0229	5	C:FXD ELECT 33 UF 10% 10VDCW	28480	0180-0229
A17C3	0140-0203	1	C:FXD 30 pF 500 VDCW	72136	08D
A17C4	0121-0436	1	C:VAR 2.4-24.5 pF	74970	189-509-105
A17C5 *	0160-0205	3	C:FXD MICA 10 PF 5%	28480	0160-0205
A17C6	0150-0093		C:FXD CER 0.01 UF +80-20% 100VDCW	72982	801-K800011
A17C7	0160-2203	5	C:FXD MICA 91 PF 5%	72136	RDM15F910J3C
A17C8	0150-0093		C:FXD CER 0.01 UF +80-20% 100VDCW	72982	801-K800011
A17C9			NOT ASSIGNED		
A17C10			NOT ASSIGNED		
A17C11	0150-0050	3	C:FXD CER 1000 PF +80-20% 600 VDCW	56289	C067B102E102ZS26-CDH
A17C12	0150-0050		C:FXD CER 1000 PF +80-20% 600 VDCW	56289	C067B102E102ZS26-CDH
A17C13	0150-0050		C:FXD CER 1000 PF +80-20% 600 VDCW	56289	C067B102E102ZS26-CDH
A17C14	0160-0153	6	C:FXD MY 0.001 UF 10% 200VDCW	56289	192P10292-PTS
A17C15	0150-0093		C:FXD CER 0.01 UF +80-20% 100VDCW	72982	801-K800011
A17C16	0150-0093		C:FXD CER 0.01 UF +80-20% 100VDCW	72982	801-K800011
A17C17	0150-0093		C:FXD CER 0.01 UF +80-20% 100VDCW	72982	801-K800011
A17C18	0150-0093		C:FXD CER 0.01 UF +80-20% 100VDCW	72982	801-K800011
A17C19	0160-2005	1	C:FXD MICA 230PF 1% 500VDCW	04062	RDM15F231F5C
A17C20	0140-0208	3	C:FXD MICA 680 PF 5%	72136	RDM15F681J3C
A17C21	0150-0093		C:FXD CER 0.01 UF +80-20% 100VDCW	72982	801-K800011
A17C22	0150-0093		C:FXD CER 0.01 UF +80-20% 100VDCW	72982	801-K800011
A17C23	0150-0093		C:FXD CER 0.01 UF +80-20% 100VDCW	72982	801-K800011
A17C24	0150-0093		C:FXD CER 0.01 UF +80-20% 100VDCW	72982	801-K800011
A17C25	0150-0093		C:FXD CER 0.01 UF +80-20% 100VDCW	72982	801-K800011
A17C26	0150-0093		C:FXD CER 0.01 UF +80-20% 100VDCW	72982	801-K800011
A17C27	0150-0093		C:FXD CER 0.01 UF +80-20% 100VDCW	72982	801-K800011
A17C28	0150-0093		C:FXD CER 0.01 UF +80-20% 100VDCW	72982	801-K800011
A17C29	0180-1746		C:FXD ELECT 15 UF 10% 20VDCW	28480	0180-1746
A17C30	0180-1746		C:FXD ELECT 15 UF 10% 20VDCW	28480	0180-1746
A17C31	0150-0093		C:FXD CER 0.01 UF +80-20% 100VDCW	72982	801-K800011
A17CR1	0122-0059	1	DIODE: VOLTAGE VAR	14430	T-048 08D
A17CR2	1902-0777	1	DIODE: ZENER 6.2V	04713	1N825
A17CR3	1902-0623		DIODE:ZENER 5.11V	28480	1902-0623
A17F1	2110-0077	1	FUSE: 1/8 A	28480	2110-0077
A17C1	1820-0751		IC:TTL PRESETTABLE DECADE COUNTER(50MHZ	01295	SN74196N
A17C2	1820-0751		IC:TTL PRESETTABLE DECADE COUNTER(50MHZ	01295	SN74196N
A17C3			NOT ASSIGNED		
A17C4	1820-0174	6	IC:TTL HEX INVERTER	01295	SN7404N
A17C5	1820-0372	1	IC:TTL TRIPLE 3-INPT AND GATE	28480	1820-0372
A17C6	1820-0469		IC:DIGITAL TTL HI-SPEED F/F	01295	SN74H102N
A17L1	9140-0179	1	COIL/CHOKE 22.0 UH 10%	28480	9140-0179
A17L2	9140-0088	2	COIL:RF 0.33 UH 5%	95265	NB-0.37 P5
A17L3	9140-0096		COIL/CHOKE 1.00 UH 10%	99800	1537-12
A17L4	9140-0096		COIL/CHOKE 1.00 UH 10%	99800	1537-12
A17L5	9140-0107		COIL:FXD RF 27 UH 10%	99800	1840-38
A17L6	9140-0107		COIL:FXD RF 27 UH 10%	99800	1840-38
A17Q1	1854-0019		TSTR:SI NPN	28480	1854-0019
A17Q2	1854-0019		TSTR:SI NPN	28480	1854-0019
A17Q3	1854-0009		TSTR:SI NPN	80131	2N709
A17Q4			NOT ASSIGNED		

See introduction to this section for ordering information

Table 6-1. Replaceable Parts

Reference Designation	HP Part Number	Qty	Description	Mfr Code	Mfr Part Number
A1705			NOT ASSIGNED		
A1706	1853-0203		TSTR:SI PNP	28480	1853-0203
A1707	1853-0203		TSTR:SI PNP	28480	1853-0203
A1708	1853-0203		TSTR:SI PNP	28480	1853-0203
A1709	1853-0203		TSTR:SI PNP	28480	1853-0203
A17010	1853-0203		TSTR:SI PNP	28480	1853-0203
A17011	1853-0203		TSTR:SI PNP	28480	1853-0203
A17K1	0683-5125	15	R:FXD COMP 5100 OHM 5% 1/4W	01121	CB 5125
A17K2	0683-3325		R:FXD COMP 3300 OHM 5% 1/4W	01121	CB 3325
A17R3	0757-0453		R:FXD MET FLM 30.1K OHM 1% 1/8W	28480	0757-0453
A17K4	0683-3915	4	R:FXD COMP 390 OHM 5% 1/4W	01121	CB 3915
A17R5	0683-4715		R:FXD COMP 470 OHM 5% 1/4W	01121	CB 4715
A17R6	0683-1535		R:FXD COMP 15K OHM 5% 1/4W	01121	CB 1535
A17R7	0683-3035	2	R:FXD COMP 30K OHM 5% 1/4W	01121	CB 3035
A17R8	0683-3035		R:FXD COMP 30K OHM 5% 1/4W	01121	CB 3035
A17R9	0683-4715		R:FXD COMP 470 OHM 5% 1/4W	01121	CB 4715
A17K10	0683-1025		R:FXD COMP 1000 OHM 5% 1/4W	01121	CB 1025
A17R11	0683-4715		R:FXD COMP 470 OHM 5% 1/4W	01121	CB 4715
A17R12	0583-2225	2	R:FXD COMP 2.2K OHM 5% 1/4W	01121	CB 2225
A17R13	0683-1025		R:FXD COMP 1000 OHM 5% 1/4W	01121	CB 1025
A17R14	0683-1025		R:FXD COMP 1000 OHM 5% 1/4W	01121	CB 1025
A17K15	0683-1055		R:FXD COMP 1 MEGOHM 5% 1/4W	01121	CB 1055
A17R16			NOT ASSIGNED		
A17K17	0683-1025		R:FXD COMP 1000 OHM 5% 1/4W	01121	CB 1025
A17R18			NOT ASSIGNED		
A17R19	0683-4715		R:FXD COMP 470 OHM 5% 1/4W	01121	CB 4715
A17R20	0683-4715		R:FXD COMP 470 OHM 5% 1/4W	01121	CB 4715
A17K21	0683-4715		R:FXD COMP 470 OHM 5% 1/4W	01121	CB 4715
A17K22	0757-0415	2	R:FXD MET FLM 475 OHM 1% 1/8W	28480	0757-0415
A17R23	0683-1025		R:FXD COMP 1000 OHM 5% 1/4W	01121	CB 1025
A17R24	0683-5125		R:FXD COMP 5100 OHM 5% 1/4W	01121	CB 5125
A17K25	0683-4715		R:FXD COMP 470 OHM 5% 1/4W	01121	CB 4715
A17R26	0683-5125		R:FXD COMP 5100 OHM 5% 1/4W	01121	CB 5125
A17R27	0683-4705		R:FXD COMP 47 OHM 5% 1/4W	01121	CB 4705
A17R28	0683-5125	4	R:FXD COMP 5100 OHM 5% 1/4W	01121	CB 5125
A17R29	0683-6215		R:FXD COMP 620 OHM 5% 1/4W	01121	CB 6215
A17R30	0683-4705		R:FXD COMP 47 OHM 5% 1/4W	01121	CB 4705
A17R31	0683-6215		R:FXD COMP 620 OHM 5% 1/4W	01121	CB 6215
A17R32	0683-1025		R:FXD COMP 1000 OHM 5% 1/4W	01121	CB 1025
A17R33	0683-5125		R:FXD COMP 5100 OHM 5% 1/4W	01121	CB 5125
A17R34	0683-4715		R:FXD COMP 470 OHM 5% 1/4W	01121	CB 4715
A17R35	0683-5125		R:FXD COMP 5100 OHM 5% 1/4W	01121	CB 5125
A17R36	0683-4705		R:FXD COMP 47 OHM 5% 1/4W	01121	CB 4705
A17R37	0683-5125		R:FXD COMP 5100 OHM 5% 1/4W	01121	CB 5125
A17R38	0683-6215		R:FXD COMP 620 OHM 5% 1/4W	01121	CB 6215
A17R39	0683-4705		R:FXD COMP 47 OHM 5% 1/4W	01121	CB 4705
A17R40	0683-2015		R:FXD COMP 200 OHM 5% 1/4W	01121	CB 2015
A17R41	0683-1025		R:FXD COMP 1000 OHM 5% 1/4W	01121	CB 1025
A17R42	0683-5125		R:FXD COMP 5100 OHM 5% 1/4W	01121	CB 5125
A17R43	0683-4715		R:FXD COMP 470 OHM 5% 1/4W	01121	CB 4715
A17R44	0683-5125		R:FXD COMP 5100 OHM 5% 1/4W	01121	CB 5125
A17R45	0683-4705		R:FXD COMP 47 OHM 5% 1/4W	01121	CB 4705
A17R46	0683-5125		R:FXD COMP 5100 OHM 5% 1/4W	01121	CB 5125
A17R47	0683-6215		R:FXD COMP 620 OHM 5% 1/4W	01121	CB 6215
A17R48	0683-4705		R:FXD COMP 47 OHM 5% 1/4W	01121	CB 4705
A17R49	0683-2015		R:FXD COMP 200 OHM 5% 1/4W	01121	CB 2015
A17R50	0683-4705		R:FXD COMP 47 OHM 5% 1/4W	01121	CB 4705
A17Y1	0410-0438	1	CRYSTAL: QUARTZ	28480	0410-0438
A18	03330-66515	1	PC ASSY: REFERENCE SMP BOARD	28480	03330-66515
A18C1	0150-0093		C:FXD CER 0.01 UF +80% -20% 100VDCW	72982	801-K800011
A18C2	0150-0093		C:FXD CER 0.01 UF +80% -20% 100VDCW	72982	801-K800011
A18C3	0160-0205		C:FXD MICA 10 PF 5%	28480	0160-0205
A18C4	0140-0214		C:FXD MICA 50 PF 5%	28480	0140-0214
A18C5	0150-0093		C:FXD CER 0.01 UF +80-20% 100VDCW	72982	801-K800011
A18C6	0150-0093		C:FXD CER 0.01 UF +80-20% 100VDCW	72982	801-K800011
A18C7	0140-0176	1	C:FXD MICA 100 PF 2%	28480	0140-0176
A18C8	0150-0093		C:FXD CER 0.01 UF +80-20% 100VDCW	72982	801-K800011
A18C9	0150-0093		C:FXD CER 0.01 UF +80-20% 100VDCW	72982	801-K800011
A18C10	0150-0093		C:FXD CER 0.01 UF +80-20% 100VDCW	72982	801-K800011
A18C11	0150-0093		C:FXD CER 0.01 UF +80-20% 100VDCW	72982	801-K800011
A18C12	0140-0198		C:FXD MICA 200 PF 5%	72136	RDML5F201J3C
A18C13	0150-0093		C:FXD CER 0.01 UF +80 -20% 100VDCW	72982	801-K800011
A18C14			NOT ASSIGNED		
A18C15	0140-0216	1	C:FXD MICA 120 PF 2%	28480	0140-0216
A18C16	0150-0093		C:FXD CER 0.01 UF +80-20% 100VDCW	72982	801-K800011
A18C17	0150-0093		C:FXD CER 0.01 UF +80-20% 100VDCW	72982	801-K800011
A18C18	0160-0155		C:FXD MY 0.0033 UF 10% 200VDCW	56289	192P33292-PTS
A18C19	0160-0155		C:FXD MY 0.0033 UF 10% 200VDCW	56289	192P33292-PTS
A18C20	0160-0363	6	C:FXD MICA 620PF 5%	28480	0160-0363
A18C21	0160-0155		C:FXD MY 0.0033 UF 10% 200VDCW	56289	192P33292-PTS
A18C22	0160-0363		C:FXD MICA 620 PF 5% 300VDCW	28480	0160-0363
A18C23	0180-1746		C:FXD ELECT 15 UF 10% 20VDCW	28480	0180-1746
A18C24	0180-1746		C:FXD ELECT 15 UF 10% 20VDCW	28480	0180-1746

See introduction to this section for ordering information

Table 6-1. Replaceable Parts(Cont'd)

Reference Designation	HP Part Number	Qty	Description	Mfr Code	Mfr Part Number
A18C25	0180-1746		C:FXD ELECT 15 UF 10% 20VDCW	28480	0180-1746
A18C26			NOT ASSIGNED		
A18C27	0180-1746		C:FXD ELECT 15 UF 10% 20VDCW	28480	0180-1746
A18CR1	1901-0040		DIODE:SILICON 30MA 30WV	07263	FDG1088
A18CR2	1901-0040		DIODE:SILICON 30MA 30WV	07263	FDG1088
A18CR3	1901-0040		DIODE:SILICON 30MA 30WV	07263	FDG1088
A18CR4	1901-0040		DIODE:SILICON 30MA 30WV	07263	FDG1088
A18CR5	1901-0040		DIODE:SILICON 30MA 30WV	07263	FDG1088
A18CR6	1901-0040		DIODE:SILICON 30MA 30WV	07263	FDG1088
A18CR7	1901-0040		DIODE:SILICON 30MA 30WV	07263	FDG1088
A18IC1	1820-0370		IC:TTL HS QUAD 2-INPT NAND GATE	01295	SN74H00N
A18IC2	1826-0043		IC:LINEAR OPERATIONAL AMPLIFIER	28480	1826-0043
A18IC3	1820-0751	1	IC:DIGITAL TTL	14430	SN33585
A18IC4	1820-0304	3	IC:TTL J-K M/S F/F W/CLOCKED & INPTS	01295	SN7472N
A18L1	9100-1614	3	COIL/CHOKE:0.82 UH 10%	28480	9100-1614
A18L2	9140-0088		COIL:RF 0.33 UH 5%	95265	NS-0.37 PS
A18L3			NOT ASSIGNED		
A18L4	9140-0129	1	COIL:FXD RF 220 UH	28480	9140-0129
A18L5	9100-1620	1	COIL:MOLDED CHOKE 15.0 UH 10%	28480	9100-1620
A18L6	9100-1629	2	COIL/CHOKE 47.0 UH 5%	28480	9100-1629
A18L7	9140-0107		COIL:FXD RF 27 UH 10%	99800	1840-38
A18L8	9100-1618		CJIL:MOLDED CHOKE 5.60 UH	28480	9100-1618
A18L9	9140-0107		COIL:FXD RF 27 UH 10%	99800	1840-38
A18L10	9100-1629		CJIL/CHOKE 47.0 UH 5%	28480	9100-1629
A18L11	9140-0107		COIL:FXD RF 27 UH 10%	99800	1840-38
A18Q1	1854-0019		TSTR:SI NPN	28480	1854-0019
A18Q2	1854-0354		TSTR:SI NPN	28480	1854-0354
A18Q3	1854-0019		TSTR:SI NPN	28480	1854-0019
A18Q4	1854-0019		TSTR:SI NPN	28480	1854-0019
A18Q5	1854-0009		TSTR:SI NPN	80131	2N709
A18Q6	1854-0019		TSTR:SI NPN	28480	1854-0019
A18Q7			NOT ASSIGNED		
A18Q8	1854-0019		TSTR:SI NPN	28480	1854-0019
A18K1	0683-3315		R:FXD COMP 330 OHM 5% 1/4W	01121	CB 3315
A18K2	0683-1835	1	R:FXD COMP 18K OHM 5% 1/4W	01121	CB 1835
A18K3	0683-4705		R:FXD COMP 47 OHM 5% 1/4W	01121	CB 4705
A18K4	0683-1025		R:FXD COMP 1000 OHM 5% 1/4W	01121	CB 1025
A18K5			NOT ASSIGNED		
A18K6	0683-3315		R:FXD COMP 330 OHM 5% 1/4W	01121	CB 3315
A18R7	0683-3315		R:FXD COMP 330 OHM 5% 1/4W	01121	CB 3315
A18R8	0683-4715		R:FXD COMP 470 OHM 5% 1/4W	01121	CB 4715
A18R9	0683-1005		R:FXD COMP 10 OHM 5% 1/4W	01121	CB 1005
A18R10	0683-2025		R:FXD COMP 2000 OHM 5% 1/4W	01121	CB 2025
A18R11	0683-2025		R:FXD COMP 2000 OHM 5% 1/4W	01121	CB 2025
A18R12	0683-1035		R:FXD COMP 10K OHM 5% 1/4W	01121	CB 1035
A18R13	0683-1035		R:FXD COMP 10K OHM 5% 1/4W	01121	CB 1035
A18R14	0757-0465		R:FXD MET FLM 100K OHM 1% 1/8W	28480	0757-0465
A18R15	0757-0465	5	R:FXD MET FLM 100K OHM 1% 1/8W	28480	0757-0465
A18R16	0757-0442		R:FXD MET FLM 10.0K OHM 1% 1/8W	28480	0757-0442
A18R17	0683-2025		R:FXD COMP 2000 OHM 5% 1/4W	01121	CB 2025
A18R18	0757-0465		R:FXD MET FLM 100K OHM 1% 1/8W	28480	0757-0465
A18R19	0683-4725		R:FXD COMP 4700 OHM 5% 1/4W	01121	CB 4725
A18R20	0683-4725		R:FXD COMP 4700 OHM 5% 1/4W	01121	CB 4725
A18R21	0683-4725		R:FXD COMP 4700 OHM 5% 1/4W	01121	CB 4725
A18R22	0683-4705		R:FXD COMP 47 OHM 5% 1/4W	01121	CB 4705
A18R23	0683-4705		R:FXD COMP 47 OHM 5% 1/4W	01121	CB 4705
A18R24	0683-4705		R:FXD COMP 47 OHM 5% 1/4W	01121	CB 4705
A18R25	0683-1025		R:FXD COMP 1000 OHM 5% 1/4W	01121	CB 1025
A18R26	0683-3315		R:FXD COMP 330 OHM 5% 1/4W	01121	CB 3315
A18R27	0683-3315		R:FXD COMP 330 OHM 5% 1/4W	01121	CB 3315
A18R28	0683-1035		R:FXD COMP 10K OHM 5% 1/4W	01121	CB 1035
A18R29	0683-1025		R:FXD COMP 1000 OHM 5% 1/4W	01121	CB 1025
A18R30	0683-4705		R:FXD COMP 47 OHM 5% 1/4W	01121	CB 4705
A18R31	0683-2015		R:FXD COMP 200 OHM 5% 1/4W	01121	CB 2015
A18R32	0683-4715		R:FXD COMP 470 OHM 5% 1/4W	01121	CB 4715
A18R33	0683-4725		R:FXD COMP 4700 OHM 5% 1/4W	01121	CB 4725
A18R34			NOT ASSIGNED		
A18R35			NOT ASSIGNED		
A18R36	0683-2425	1	R:FXD COMP 2400 OHM 5% 1/4W	01121	CB 2425
A18R37	0683-4705		R:FXD COMP 47 OHM 5% 1/4W	01121	CB 4705
A18R38	0683-3025		R:FXD COMP 3000 OHM 5% 1/4W	01121	CB 3025
A18R39	0683-2015		R:FXD COMP 200 OHM 5% 1/4W	01121	CB 2015
A18R40	0683-4705		R:FXD COMP 47 OHM 5% 1/4W	01121	CB 4705
A18R41	0683-2025		R:FXD COMP 2000 OHM 5% 1/4W	01121	CB 2025

See introduction to this section for ordering information

Table 6-1. Replaceable Parts(Cont'd)

Reference Designation	HP Part Number	Qty	Description	Mfr Code	Mfr Part Number
A18R42	0683-2025	1	R:FXD COMP 2000 OHM 5% 1/4W	01121	CB 2025
A18T1	9100-1393		TRANSFORMER:TURJID	28480	9100-1393
A19	03330-66516		PC ASSY:SWEPT GENERATOR	28480	03330-66516
A19C1	0150-0093		C:FXD CER 0.01 UF +80-20% 100VDCW	72982	801-K800011
A19C2	0160-0153		C:FXD MY 0.001 UF 10% 200VDCW	56289	192P10292-PTS
A19C3	0180-0229		C:FXD ELECT 33 UF 10% 10VDCW	28480	0180-0229
A19C4	0150-0093	C:FXD CER 0.01 UF +80-20% 100VDCW	72982	801-K800011	
A19C5	0150-0093	C:FXD CER 0.01 UF +80-20% 100VDCW	72982	801-K800011	
A19C6	0150-0093	C:FXD CER 0.01 UF +80-20% 100VDCW	72982	801-K800011	
A19CR1	1902-0777	3	DIODE:BREAKDOWN 6.2V 5%	04713	1N825
A19CR2	1902-0777	5	DIODE:BREAKDOWN 6.2V 5%	04713	1N825
A19CR3	1901-0044		DIODE:SILICON 20MA/1V	28480	1901-0044
A19CR4	1902-0041		DIODE:BREAKDOWN 5.11V 5%	04713	SZ10939-98
A19IC1	1820-0216		IC:OP. AMP. AVOL=50K MIN.	28480	1820-0216
A19IC2	1820-0216		IC:OP. AMP. AVOL=50K MIN.	28480	1820-0216
A19IC3	1820-0539	1	IC:TTL QUAD 2-INPT NAND BUFFER	01295	SN7437N
A19IC4 THRU	1820-0301	3	IC:TTL QUAD BI-STABLE D-LATCH	01295	SN7475N
A19IC6	1820-0174		IC:TTL HEX INVERTER	01295	SN7404N
A19IC7	1820-0273		IC:DTL QUAD 2-INPT AND GATE	28480	1820-0273
A19IC8	1820-0273	5	IC:DTL QUAD 2-INPT AND GATE	28480	1820-0273
A19IC9	1820-0174		IC:TTL HEX INVERTER	01295	SN7404N
A19IC10	1820-0216		IC:OP. AMP. AVOL=50K MIN.	28480	1820-0216
A19IC11	1820-0537		IC:TTL DUAL 4-INPT NAND GATE	28480	1820-0537
A19IC12	1820-0174		IC:TTL HEX INVERTER	01295	SN7404N
A19Q1	1853-0066	12	TSTR:SI PNP	28480	1853-0020
A19Q2	1854-0071		TSTR:SI NPN	28480	1854-0071
A19Q3	1853-0066	8	TSTR:SI PNP	28480	1853-0020
A19Q4	1854-0071		TSTR:SI NPN	28480	1854-0071
A19Q5	1853-0066		TSTR:SI PNP	28480	1853-0020
A19Q6	1854-0071		TSTR:SI NPN	28480	1854-0071
A19Q7	1853-0066		TSTR:SI PNP(SELECTED FROM 2N3702)	28480	1853-0020
A19Q8	1854-0071		TSTR:SI NPN	28480	1854-0071
A19Q9	1853-0020		TSTR:SI PNP(SELECTED FROM 2N3702)	28480	1853-0020
A19Q10	1854-0071		TSTR:SI NPN(SELECTED FROM 2N3704)	28480	1854-0071
A19Q11	1853-0020		TSTR:SI PNP(SELECTED FROM 2N3702)	28480	1853-0020
A19Q12	1854-0071		TSTR:SI NPN(SELECTED FROM 2N3704)	28480	1854-0071
A19Q13	1853-0020	TSTR:SI PNP(SELECTED FROM 2N3702)	28480	1853-0020	
A19Q14	1854-0071	TSTR:SI NPN(SELECTED FROM 2N3704)	28480	1854-0071	
A19Q15	1853-0020	TSTR:SI PNP(SELECTED FROM 2N3702)	28480	1853-0020	
A19Q16	1854-0071	TSTR:SI NPN(SELECTED FROM 2N3704)	28480	1854-0071	
A19Q17	1853-0020	TSTR:SI PNP(SELECTED FROM 2N3702)	28480	1853-0020	
A19Q18	1854-0071	TSTR:SI NPN(SELECTED FROM 2N3704)	28480	1854-0071	
A19Q19	1853-0020	TSTR:SI PNP(SELECTED FROM 2N3702)	28480	1853-0020	
A19Q20	1854-0071	TSTR:SI NPN(SELECTED FROM 2N3704)	28480	1854-0071	
A19Q21	1853-0020	TSTR:SI PNP(SELECTED FROM 2N3702)	28480	1853-0020	
A19Q22	1854-0071	TSTR:SI NPN(SELECTED FROM 2N3704)	28480	1854-0071	
A19Q23	1853-0020	TSTR:SI PNP(SELECTED FROM 2N3702)	28480	1853-0020	
A19Q24	1854-0071	TSTR:SI NPN(SELECTED FROM 2N3704)	28480	1854-0071	
A19K1	0757-0434	3	R:FXD MET FLM 3.65K OHM 1% 1/8W	28480	0757-0434
A19K2	0683-3025	6	R:FXD COMP 3000 OHM 5% 1/4W	01121	CB 3025
A19K3	0683-1525		R:FXD COMP 1500 OHM 5% 1/4W	01121	CB 1525
A19K4	0683-2025		R:FXD COMP 2000 OHM 5% 1/4W	01121	CB 2025
A19K5	0683-3325		R:FXD COMP 3300 OHM 5% 1/4W	01121	CB 3325
A19K6	1810-0051		RESISTIVE NETWORK	28480	1810-0051
A19K7	0683-3025		R:FXD COMP 3 KOHM 5% 1/4W	01121	CB 3025
A19K8	0683-1525	R:FXD COMP 1.5KOHM 5% 1/4W	01121	CB 1525	
A19K9	0683-2025	R:FXD COMP 2000 OHM 5% 1/4W	01121	CB 2025	
A19K10	0683-3325	R:FXD COMP 3300 OHM 5% 1/4W	01121	CB 3325	
A19K11	0683-5625	R:FXD COMP 5.6 KOHM 5% 1/4W	01121	CB 5625	
A19K12	0683-3025	R:FXD COMP 3 KOHM 5% 1/4W	01121	CB 3025	
A19K13		NOT ASSIGNED			
A19K14	0683-4725	R:FXD COMP 4700 OHM 5% 1/4W	01121	CB 4725	
A19K15	0683-3325	R:FXD COMP 3300 OHM 5% 1/4W	01121	CB 3325	
A19K16	0683-5625	R:FXD COMP 5.6 KOHM 5% 1/4W	01121	CB 5625	
A19K17	0683-3025	R:FXD COMP 3 KOHM 5% 1/4W	01121	CB 3025	
A19K18	0683-4725	R:FXD COMP 4700 OHM 5% 1/4W	01121	CB 4725	
A19K19	0683-3325	R:FXD COMP 3300 OHM 5% 1/4W	01121	CB 3325	
A19K20		NOT ASSIGNED			
A19K21	2100-2522	5	R:VAR CERMET 10K OHM 10% LIN 1/2W	28480	2100-2522
A19K22	0698-3279	4	R:FXD MET FLM 4990 OHM 1% 1/8W	28480	0698-3279
A19K23	2100-3056		R:VAR CERMET 5K OHM 10% TYPE P 3/4W	28480	2100-3056
A19K24			NOT ASSIGNED		
A19K25			NOT ASSIGNED		
A19K26	0698-4202	1	R:FXD FLM 8.87K OHM 1% 1/8W	28480	0698-4202

See introduction to this section for ordering information

Table 6-1. Replaceable Parts(Cont'd)

Reference Designation	HP Part Number	Qty	Description	Mfr Code	Mfr Part Number
A19R27	0757-0346	12	R:FXD MET FLM 10 OHM 1% 1/8W	28480	0757-0346
A19R28	0683-6825	9	R:FXD COMP 6800 OHM 5% 1/4W	01121	CB 6825
A19R29	0683-3325		R:FXD COMP 3400 OHM 5% 1/4W	01121	CB 3325
A19R30	0683-4725		R:FXD COMP 4700 OHM 5% 1/4W	01121	CB 4725
A19R31			NOT ASSIGNED		
A19R32	0683-6825		R:FXD COMP 6800 OHM 5% 1/4W	01121	CB 6825
A19R33	0583-3325		R:FXD COMP 3300 OHM 5% 1/4W	01121	CB 3325
A19R34	0683-4725		R:FXD COMP 4700 OHM 5% 1/4W	01121	CB 4725
A19R35	0683-6825		R:FXD COMP 6800 OHM 5% 1/4W	01121	CB 6825
A19R36	0683-3325		R:FXD COMP 3300 OHM 5% 1/4W	01121	CB 3325
A19R37	0683-4725		R:FXD COMP 4700 OHM 5% 1/4W	01121	CB 4725
A19R38	0683-6825		R:FXD COMP 6800 OHM 5% 1/4W	01121	CB 6825
A19R39	0583-3325		R:FXD COMP 3300 OHM 5% 1/4W	01121	CB 3325
A19R40	0683-4725		R:FXD COMP 4700 OHM 5% 1/4W	01121	CB 4725
A19R41			NOT ASSIGNED		
A19R42			NOT ASSIGNED		
A19R43	0683-3315		R:FXD COMP 3300 OHM 5% 1/4W	01121	CB 3315
A19R44	0683-6825		R:FXD COMP 6800 OHM 5% 1/4W	01121	CB 6825
A19R45	0683-3325		R:FXD COMP 3300 OHM 5% 1/4W	01121	CB 3325
A19R46	0683-4725		R:FXD COMP 4700 OHM 5% 1/4W	01121	CB 4725
A19R47	0683-6825		R:FXD COMP 6800 OHM 5% 1/4W	01121	CB 6825
A19R48	0683-3325		R:FXD COMP 3300 OHM 5% 1/4W	01121	CB 3325
A19R49	0683-4725		R:FXD COMP 4700 OHM 5% 1/4W	01121	CB 4725
A19R50	0683-6825		R:FXD COMP 6800 OHM 5% 1/4W	01121	CB 6825
A19R51	0683-3325		R:FXD COMP 3300 OHM 5% 1/4W	01121	CB 3325
A19R52	0683-4725		R:FXD COMP 4700 OHM 5% 1/4W	01121	CB 4725
A19R53			NOT ASSIGNED		
A19R54	0683-6825		R:FXD COMP 6800 OHM 5% 1/4W	01121	CB 6825
A19R55	0683-3325		R:FXD COMP 3300 OHM 5% 1/4W	01121	CB 3325
A19R56	0683-4725		R:FXD COMP 4700 OHM 5% 1/4W	01121	CB 4725
A19R57	0757-0442		R:FXD MET FLM 10.0K OHM 1% 1/8W	28480	0757-0442
A19R58	0757-0442		R:FXD MET FLM 10.0K OHM 1% 1/8W	28480	0757-0442
A19R59	0757-0442		R:FXD MET FLM 10.0K OHM 1% 1/8W	28480	0757-0442
A19R60	0757-0440	2	R:FXD MET FLM 7.50K OHM 1% 1/8W	28480	0757-0440
A20	03330-66517	2	PC ASSY:SL2 VTD	28480	03330-66517
A20C1	0140-0156	2	C:FXD MICA 1500 PF 2%	28480	0140-0156
A20C2	0160-0945	1	C:FXD MICA 910 PF 5%	28480	0160-0945
A20C3	0160-2228	1	C:FXD MICA 2700 PF 5%	28480	0160-2228
A20C4	0180-0229		C:FXD ELECT 33 UF 10% 100VDCW	28480	0180-0229
A20C5	0150-0093		C:FXD CER 0.01 UF +80-20% 100VDCW	72982	801-K800011
A20C6	0140-0203		C:FXD MICA 30 PF 5%	28480	0140-0203
A20C7	0140-0203		C:FXD MICA 30 PF 5%	28480	0140-0203
A20C8	0150-0093		C:FXD CER 0.01 UF +80-20% 100VDCW	72982	801-K800011
A20C9	0150-0093		C:FXD CER 0.01 UF +80-20% 100VDCW	72982	801-K800011
A20C10	0150-0093		C:FXD CER 0.01 UF +80-20% 100VDCW	72982	801-K800011
A20C11	0150-0093		C:FXD CER 0.01 UF +80-20% 100VDCW	72982	801-K800011
A20C12	0150-0093		C:FXD CER 0.01 UF +80-20% 100VDCW	72982	801-K800011
A20C13	0150-0093		C:FXD CER 0.01 UF +80-20% 100VDCW	72982	801-K800011
A20C14	0150-0093		C:FXD CER 0.01 UF +80-20% 100VDCW	72982	801-K800011
A20C15	0180-1746		C:FXD ELECT 15 UF 10% 20VDCW	28480	0180-1746
A20C16	0180-1746		C:FXD ELECT 15 UF 10% 20VDCW	28480	0180-1746
A20C17	0180-0291		C:FXD ELECT 1.0 UF 10% 35VDCW	56289	150D105X9035A2-OYS
A20C18	0140-0200		C:FXD MICA 390 PF 5%	72136	ROM15F391-J3C
A20C19	0150-0093		C:FXD CER 0.01 UF +80-20% 100VDCW	72982	801-K800011
A20CR1	1901-0040		DIODE:SILICON 30MA 30WV	07263	FDG1088
A20CR2	1901-0040		DIODE:SILICON 30MA 30WV	07263	FDG1088
A20CR3	1901-0040		DIODE:SILICON 30MA 30WV	07263	FDG1088
A20CR4	0122-0059		DIODE:VOLTAGE VARIABLE CAPACITANCE	28480	0122-0059
A20CR5	0122-0059		DIODE:VOLTAGE VARIABLE CAPACITANCE	28480	0122-0059
A20IC1	1826-0043		IC:LINEAR OPERATIONAL AMPLIFIER	28480	1826-0043
A20IC2	1826-0043		IC:LINEAR OPERATIONAL AMPLIFIER	28480	1826-0043
A20IC3	1820-0751		IC:TTL PRESETTABLE DECADE COUNTER(50MHZ	01295	SN74196N
A20L1	9100-1652	2	COIL/CHOKE 820 UH 5%	82142	19-1331-33J
A20L2	9140-0210		COIL/CHOKE 100 UH 5%	82142	15-1315-12J
A20L3	9100-3312		INDUCTOR:VAR 1.00 UH 10%	28480	9100-3312
A20L4	9100-1616	2	COIL/CHOKE 1.50 UH 10%	99800	1537-16
A20L5	9140-0107		COIL:FXD RF 27 UH 10%	99800	1840-38
A20L6	9140-0107		COIL:FXD RF 27 UH 10%	99800	1840-38
A20L7	9140-0210		COIL/CHOKE 100 UH 5%	82142	15-1315-12J
A20Q1	1853-0010		TSTR:SI PNP(SELECTED FROM 2N3251)	28480	1853-0010
A20Q2	1854-0404		TSTR:SI NPN	28480	1854-0404
A20Q3	1854-0345		TSTR:SI NPN	80131	2N5179
A20Q4	1854-0345		TSTR:SI NPN	80131	2N5179
A20Q5	1854-0019		TSTR:SI NPN	28480	1854-0019
A20Q6	1854-0019		TSTR:SI NPN	28480	1854-0019

See introduction to this section for ordering information

Table 6-1. Replaceable Parts(Cont'd)

Reference Designation	HP Part Number	Qty	Description	Mfr Code	Mfr Part Number
A20Q7	1854-0009		TSTR:SI NPN	80131	2N709
A20Q8	1854-0019		TSTR:SI NPN	28480	1954-0019
A20Q9	1854-0019		TSTR:SI NPN	28480	1854-0019
A20R1	0757-0289	5	R:FXD MET FLM 13.3K OHM 1% 1/8W	28480	0757-0289
A20K2	2100-2522		R:VAR CERMET 10K OHM 10% LIN 1/2W	28460	2100-2522
A20K3	0683-1035		R:FXD COMP 10K OHM 5% 1/4W	01121	CB 1035
A20R4	2100-2516	4	R:VAR CERMET 100K OHM 10% LIN 1/2W	28480	2100-2516
A20R5	0757-0442		R:FXD MET FLM 10.0K OHM 1% 1/8W	28480	0757-0442
A20R6	2100-2522		R:VAR CERMET 10K OHM 10% LIN 1/2W	28480	2100-2522
A20K7	0683-1035		R:FXD COMP 10K OHM 5% 1/4W	01121	CB 1035
A20K8	2100-2516		R:VAR CERMET 100K OHM 10% LIN 1/2W	28480	2100-2516
A20R9	0683-1035		R:FXD COMP 10K OHM 5% 1/4W	01121	CB 1035
A20R10	0683-1555	2	R:FXD COMP 1.5 MEGOHM 5% 1/4W	01121	CB 1555
A20R11	0698-6719	2	R:FXD FLM 15K OHM 1% 1/8W	28480	0698-6719
A20R12	0698-4527	2	R:FXD FLM 205K OHM 1% 1/8W	28480	0698-4527
A20R13	0698-3279		R:FXD MET FLM 4990 OHM 1% 1/8W	28480	0698-3279
A20R14	0698-8235	2	R:FXD FLM 9.31K OHM 1% 1/8W	28480	0698-8235
A20R15	2100-3056		R:VAR CERMET 5K OHM 10% TYPE P 3/4W	28480	2100-3056
A20R16	0698-3279		R:FXD MET FLM 4990 OHM 1% 1/8W	28480	0698-3279
A20R17	0698-3279		R:FXD MET FLM 4990 OHM 1% 1/8W	28480	0698-3279
A20R18	0757-0280		R:FXD MET FLM 1K OHM 1% 1/8W	28480	0757-0280
A20R19	0683-1035		R:FXD COMP 10K OHM 5% 1/4W	01121	CB 1035
A20R20	0683-4705		R:FXD COMP 47 OHM 5% 1/4W	01121	CB 4705
A20R21	0683-1035		R:FXD COMP 10K OHM 5% 1/4W	01121	CB 1035
A20R22	0683-4735		R:FXD COMP 47K OHM 5% 1/4W	01121	CB 4735
A20R23	0683-2025		R:FXD COMP 2000 OHM 5% 1/4W	01121	CB 2025
A20R24			NOT ASSIGNED		
A20R25	0683-6225		R:FXD COMP 6200 OHM 5% 1/4W	01121	CB 6225
A20R26	0683-4705		R:FXD COMP 47 OHM 5% 1/4W	01121	CB 4705
A20R27	0683-3025		R:FXD COMP 3000 OHM 5% 1/4W	01121	CB 3025
A20R28	0683-4705		R:FXD COMP 47 OHM 5% 1/4W	01121	CB 4705
A20R29	0683-1225		R:FXD COMP 1200 OHM 5% 1/4W	01121	CB 1225
A20R30	0683-2015		R:FXD COMP 200 OHM 5% 1/4W	01121	CB 2015
A20R31	0683-4705		R:FXD COMP 47 OHM 5% 1/4W	01121	CB 4705
A20R32	0683-1035		R:FXD COMP 10K OHM 5% 1/4W	01121	CB 1035
A20R33	0683-1025		R:FXD COMP 1000 OHM 5% 1/4W	01121	CB 1025
A20R34	0683-4725		R:FXD COMP 4700 OHM 5% 1/4W	01121	CB 4725
A20R35	0683-2215	3	R:FXD COMP 220 OHM 5% 1/4W	01121	CB 2215
A20R36	0683-4705		R:FXD COMP 47 OHM 5% 1/4W	01121	CB 4705
A20R37	0683-4725		R:FXD COMP 4700 OHM 5% 1/4W	01121	CB 4725
A20R38	0683-1015		R:FXD COMP 100 OHM 5% 1/4W	01121	CB 1015
A20R39	0683-4725		R:FXD COMP 4700 OHM 5% 1/4W	01121	CB 4725
A20R40	0683-4705		R:FXD COMP 47 OHM 5% 1/4W	01121	CB 4705
A20R41	0683-6815		R:FXD COMP 680 OHM 5% 1/4W	01121	CB 6815
A20R42	0683-2025		R:FXD COMP 2000 OHM 5% 1/4W	01121	CB 2025
A20R43	0683-4735		R:FXD COMP 47K OHM 5% 1/4W	01121	CB 4735
A20SW1	3101-1341		SWITCH:SLIDE SPDT 0.5A 125V AC/DC	79727	C-111-0004
A21 Δ13	03330-66532	2	PC ASSY:SL2 MIX/PH. DET.	28480	03330-66532
A21C1	0150-0093		C:FXD CER 0.01 UF +80-20% 100VDCW	72982	801-K800011
A21C2	0150-0093		C:FXD CER 0.01 UF +80-20% 100VDCW	72982	801-K800011
A21C3	0150-0093		C:FXD CER 0.01 UF +80-20% 100VDCW	72982	801-K800011
A21C4	0160-2203		C:FXD MICA 91 PF 5%	72136	RDML5F910J3C
A21C5	0140-0210	3	C:FXD MICA 270 PF 5%	28480	0140-0210
A21C6	0150-0093		C:FXD CER 0.01 UF +80-20% 100VDCW	72982	801-K800011
A21C7	0140-0198		C:FXD MICA 200 PF 5%	72136	RDML5F201J3C
A21C8	0160-2009		C:FXD MICA 820 PF 5% 300VDCW	00853	RDML5F821J3C
A21C9	0160-2202	4	C:FXD MICA 75 PF 5%	28480	0160-2202
A21C10	0140-0198		C:FXD MICA 200 PF 5%	72136	RDML5F201J3C
A21C11	0160-0362		C:FXD MICA 510PF 5%	28480	0160-0362
A21C12	0160-2221	1	C:FXD MICA 1300 PF 5%	28480	0160-2221
A21C13	0140-0177	1	C:FXD MICA 400 PF 1%	28480	0140-0177
A21C14	0140-0156		C:FXD MICA 1500 PF 2%	28480	0140-0156
A21C15	0180-1746		C:FXD ELECT 15 UF 10% 20VDCW	28480	0180-1746
A21C16	0180-1746		C:FXD ELECT 15 UF 10% 20VDCW	28480	0180-1746
A21C17	0180-1746		C:FXD ELECT 15 UF 10% 20VDCW	28480	0180-1746
A21C18	0160-3077	3	C:FXD MY 0.027 UF 10% 100VDCW	56289	225P2739WB1-PWM
A21C19	0160-2201	2	C:FXD MICA 51 PF 5%	72136	RDML5E510J3C
A21C20	0160-2009		C:FXD MICA 820 PF 5% 300VDCW	00853	RDML5F821J3C
A21C21	0160-2202		C:FXD MICA 75 PF 5%	28480	0160-2202
A21C22 Δ1	0160-2201	1	C:FXD 51PF 300VDCW	28480	0160-2201
A21CR1			NOT ASSIGNED		
A21CR2			NOT ASSIGNED		
A21CR3			NOT ASSIGNED		
A21CR4	1901-0040		DIODE:SILICON 30MA 30WV	07263	FDG1088
A21IC1	1858-0019	2	TSTR ARRAY:DUAL INDEP. DIFFERENTIAL	02735	CA 3054
A21IC2	1820-0751		IC:TTL PRESETTABLE DECADE COUNTER(50MHZ)	01295	SN74196N

See introduction to this section for ordering information

Table 6-1. Replaceable Parts(Cont'd)

Reference Designation	HP Part Number	Qty	Description	Mfr Code	Mfr Part Number
A21IC3	1820-0537		IC:TTL DUAL 4-INPT NAND GATE	28480	1820-0537
A21IC4	1820-0174		IC:TTL HEX INVERTER	01295	SN7404N
A21IC5	1820-0907	2	IC:TTL TRIPLE 3-INPT NAND GATE	01295	SN7412N
A21IC6	1820-0511	3	IC:TTL QUAD 2-INPT AND GATE	01295	SN7408N
A21IC7	1820-0537		IC:TTL DUAL 4-INPT NAND GATE	28480	1820-0537
A21IC8	1820-0616	2	IC:TTL 4-BIT 2-INPT MULTIPLEXER	07263	U78932259X
A21IC9 Δ13	1816-0991	2	BI-POLAR MEMORY	28480	1816-0991
A21IC10	1820-0304		IC:TTL J-K M/S F/F W/CLOCKED & INPTS	01295	SN7472N
A21IC11	1820-0075	2	IC:TTL DUAL J-K MASTER SLAVE F/F	01295	SN7473N
A21L1	9100-1627	5	COIL/CHOKE 39 UH 5%	82142	15-1315-2J
A21L2	9140-0210		COIL/CHOKE 100 UH 5%	82142	15-1315-12J
A21L3	9140-0210		COIL/CHOKE 100 UH 5%	82142	15-1315-12J
A21L4	9100-1652		COIL/CHOKE 820 UH 5%	82142	19-1331-33J
A21L5	9140-0107		COIL:FXD RF 27 UH 10%	99800	1840-38
A21L6	9100-1618		COIL:MCLOED CHOKE 5.60 UH	28480	9100-1618
A21L7	9140-0107		COIL:FXD RF 27 UH 10%	99800	1840-38
A21Q1	1854-0404		TSTR:SI NPN	28480	1854-0404
A21Q2	1853-0010		TSTR:SI PNP(SELECTED FROM 2N3251)	28480	1853-0010
A21Q3	1854-0404		TSTR:SI NPN	28480	1854-0404
A21Q4	1855-0081		TSTR:SI FET	80131	2N5245
A21Q5	1853-0010		TSTR:SI PNP(SELECTED FROM 2N3251)	28480	1853-0010
A21R1	0683-2015		R:FXD COMP 200 OHM 5% 1/4W	01121	CB 2015
A21R2	0683-5105		R:FXD COMP 51 OHM 5% 1/4W	01121	CB 5105
A21R3	0683-3915		R:FXD COMP 390 OHM 5% 1/4W	01121	CB 3915
A21R4	0683-3915		R:FXD COMP 390 OHM 5% 1/4W	01121	CB 3915
A21R5	0683-2015		R:FXD COMP 200 OHM 5% 1/4W	01121	CB 2015
A21R6	0683-2015		R:FXD COMP 200 OHM 5% 1/4W	01121	CB 2015
A21R7	0683-1525		R:FXD COMP 1500 OHM 5% 1/4W	01121	CB 1525
A21R8	0683-2015		R:FXD COMP 200 OHM 5% 1/4W	01121	CB 2015
A21R9	0683-1035		R:FXD COMP 10K OHM 5% 1/4W	01121	CB 1035
A21K10	0683-4725		R:FXD COMP 4700 OHM 5% 1/4W	01121	CB 4725
A21K11	0683-3925	1	R:FXD COMP 3900 OHM 5% 1/4W	01121	CB 3925
A21K12	0683-2035		R:FXD COMP 20K OHM 5% 1/4W	01121	CB 2035
A21K13	0683-2025		R:FXD COMP 2000 OHM 5% 1/4W	01121	CB 2025
A21K14	0683-2025		R:FXD COMP 2000 OHM 5% 1/4W	01121	CB 2025
A21R15	0683-3015		R:FXD COMP 300 OHM 5% 1/4W	01121	CB 3015
A21K16	0683-8215	4	R:FXD COMP 820 OHM 5% 1/4W	01121	CB 8215
A21K17	0683-2025		R:FXD COMP 2000 OHM 5% 1/4W	01121	CB 2025
A21R18	0683-1025		R:FXD COMP 1000 OHM 5% 1/4W	01121	CB 1025
A21R19	0683-3015		R:FXD COMP 300 OHM 5% 1/4W	01121	CB 3015
A21K20	0683-4725		R:FXD COMP 4700 OHM 5% 1/4W	01121	CB 4725
A21R21	0683-8215		R:FXD COMP 820 OHM 5% 1/4W	01121	CB 8215
A21R22	0683-2025		R:FXD COMP 2000 OHM 5% 1/4W	01121	CB 2025
A21K23	0683-3015		R:FXD COMP 300 OHM 5% 1/4W	01121	CB 3015
A21R24	0683-1025		R:FXD COMP 1000 OHM 5% 1/4W	01121	CB 1025
A21K25	0683-1025		R:FXD COMP 1000 OHM 5% 1/4W	01121	CB 1025
A21R26	0683-1025		R:FXD COMP 1000 OHM 5% 1/4W	01121	CB 1025
A21R27	0683-1025		R:FXD COMP 1000 OHM 5% 1/4W	01121	CB 1025
A21R28	0683-1025		R:FXD COMP 1000 OHM 5% 1/4W	01121	CB 1025
A21K29	0683-1025		R:FXD COMP 1000 OHM 5% 1/4W	01121	CB 1025
A21R30	0683-1025		R:FXD COMP 1000 OHM 5% 1/4W	01121	CB 1025
A21R31	0683-2035		R:FXD COMP 20K OHM 5% 1/4W	01121	CB 2035
A21R32	0683-5125		R:FXD COMP 5100 OHM 5% 1/4W	01121	CB 5125
A21R33	0683-5125		R:FXD COMP 5100 OHM 5% 1/4W	01121	CB 5125
A21R34	0683-1135	2	R:FXD COMP 11K OHM 5% 1/4W	01121	CB 1135
A21R35	0683-2035		R:FXD COMP 20K OHM 5% 1/4W	01121	CB 2035
A21R36	0683-4725		R:FXD COMP 4700 OHM 5% 1/4W	01121	CB 4725
A21R37	0683-4725		R:FXD COMP 4700 OHM 5% 1/4W	01121	CB 4725
A21R38	0683-4725		R:FXD COMP 4700 OHM 5% 1/4W	01121	CB 4725
A21R39	0683-1525		R:FXD COMP 1500 OHM 5% 1/4W	01121	CB 1525
A21K40	0683-3325		R:FXD COMP 3300 OHM 5% 1/4W	01121	CB 3325
A21R41	0683-5115		R:FXD COMP 510 OHM 5% 1/4W	01121	CB 5115
A21K42	0683-1025		R:FXD COMP 1000 OHM 5% 1/4W	01121	CB 1025
A21R43	0683-1025		R:FXD COMP 1000 OHM 5% 1/4W	01121	CB 1025
A21SW1	3101-1341		SWITCH:SLIDE SPDT 0.5A 125V AC/DC	79727	C-111-0004
A22	03330-66517		PC ASSY: SL3 VTO (IDENTICAL TO A20)	28480	03330-66517
A23 Δ13	03330-66532	1	PC ASSY: SL1 PH. DET.	28480	03330-66532
A23C1	0150-0093		C:FXD CER 0.01 UF +80-20% 100VDCW	72982	801-K800011
A23C2	0140-0198		C:FXD MICA 200 PF 5%	72136	RD15F201J3C
A23C3	0160-0363		C:FXD MICA 620PF 5%	28480	0160-0363
A23C4	0180-0291		C:FXD ELECT 1.0 UF 10% 35VDCW	56289	150D105X9035A2-DYS
A23C5	0140-0198		C:FXD MICA 200 PF 5%	72136	RD15F201J3C
A23C6	0160-2009		C:FXD MICA 820 PF 5% 300VDCW	00853	RD15F821J3C
A23C7	0160-2009		C:FXD MICA 820 PF 5% 300VDCW	00853	RD15F821J3C
A23C8	0160-2202		C:FXD MICA 75 PF 5%	28480	0160-2202

See introduction to this section for ordering information

Table 6-1. Replaceable Parts(Cont'd)

Reference Designation	HP Part Number	Qty	Description	Mfr Code	Mfr Part Number
A23C9	0160-0362		C:FXD MICA 513PF 5%	28480	0160-0362
A23C10	0180-0229		C:FXD ELECT 33 UF 10% 10VDCW	28480	0180-0229
A23C11	0160-0940	1	C:FXD MICA 2400 PF 5%	00853	RDM19F242J5C
A23C12	0140-0210		C:FXD MICA 270 PF 5%	28480	0140-0210
A23C13	0160-2031	2	C:FXD MICA 3630 PF 5% 500VDCW	00853	RDM20F362J5S
A23C14	0140-0208		C:FXD MICA 680 PF 5%	72136	RDM15F681J3C
A23C15	0160-0980	1	C:FXD MICA 6200 PF 2%	00853	RDM19F622G3S
A23C16	0170-0079		C:FXD MY 0.047UF 20% 50VDCW	84411	STYLE 3 TYPE 601PE
A23C17	0180-1746		C:FXD ELECT 15 UF 10% 20VDCW	28480	0180-1746
A23C18	0180-1746		C:FXD ELECT 15 UF 10% 20VDCW	28480	0180-1746
A23C19	0180-1746		C:FXD ELECT 15 UF 10% 20VDCW	28480	0180-1746
A23C20	0140-0198		C:FXD MICA 200 PF 5%	72136	RDM15F201J3C
A23C21	0160-2031		C:FXD MICA 3630 PF 5% 500VDCW	00853	RDM20F362J5S
A23C22	0160-2201		C:FXD MICA 51 PF 5%	72136	RDM15E510J1C
A23C23	0160-2202		C:FXD MICA 75 PF 5%	28480	0160-2202
A23C24 Δ1	0160-2201		C:FXD MICA 51PF 5% 300VDCW	28480	0160-2201
A23CR1			NOT ASSIGNED		
A23CR2			NOT ASSIGNED		
A23CR3			NOT ASSIGNED		
A23CR4	1901-0040		DIODE:SILICON 30MA 30WV	07263	FDG1088
A23CR5	1902-0623		DIODE:ZENER	28480	1902-0623
A23IC1	1820-0537		IC:TTL DUAL 4-INPT NAND GATE	28480	1820-0537
A23IC2	1820-0537		IC:TTL DUAL 4-INPT NAND GATE	28480	1820-0537
A23IC3	1820-0907		IC:TTL TRIPLE 3-INPT NAND GATE	01295	SN74L2N
A23IC4	1820-0511		IC:TTL QUAD 2-INPT AND GATE	01295	SN7408N
A23IC5	1820-0174		IC:TTL HEX INVERTER	01295	SN7404N
A23IC6	1820-0751		IC:TTL PRESETTABLE DECADE COUNTER(50MHZ	01295	SN74196N
A23IC7	1820-0616		IC:TTL 4-BIT 2-INPT MULTIPLEXER	07263	U78932259X
A23IC8 Δ13	1816-0991		BI-POLAR MEMORY	28480	1816-0991
A23IC9	1820-0304		IC:TTL J-K M/S F/F W/CLOCKED & INPTS	01295	SN7472N
A23IC10			NOT ASSIGNED		
A23IC11	1820-0075		IC: TTL DUAL J-K MASTER SLAVE F/F	01295	SN7473N
A23IC12	1826-0043		IC: LINEAR OPERATIONAL AMPLIFIER	28480	1826-0043
A23L1	9140-0238		COIL: MLD CHOKE 82 UH 5%	99800	1537-72
A23L2	9140-0210		COIL/CHOKE 100 UH 5%	82142	15-1315-12J
A23L3	9140-0210		COIL/CHOKE 100 UH 5%	82142	15-1315-12J
A23L4	9140-0137		COIL:FXD RF 1000 UH 5%	28480	9140-0137
A23L5	9140-0137		COIL:FXD RF 1000 UH 5%	28480	9140-0137
A23L6	9140-0107		COIL:FXD RF 27 UH 10%	99800	1840-38
A23L7	9100-1618		COIL:MULDED CHOKE 5.60 UH	28480	9100-1618
A23L8	9140-0107		COIL:FXD RF 27 UH 10%	99800	1840-38
A23Q1	1854-0404		TSTR:SI NPN	28480	1854-0404
A23Q2	1854-0404		TSTR:SI NPN	28480	1854-0404
A23Q3	1853-0203		TSTR:SI PNP	28480	1853-0203
A23Q4	1853-0010		TSTR:SI PNP(SELECTED FROM 2N3251)	28480	1853-0010
A23Q5	1855-0081		TSTR:SI FET	80131	2N5245
A23R1	0683-2025		R:FXD COMP 2000 OHM 5% 1/4W	01121	CB 2025
A23R2	0683-1035		R:FXD COMP 10K OHM 5% 1/4W	01121	CB 1035
A23R3	0683-4705		R:FXD COMP 47 OHM 5% 1/4W	01121	CB 4705
A23R4	0683-1025		R:FXD COMP 1000 OHM 5% 1/4W	01121	CB 1025
A23R5	0683-2025		R:FXD COMP 2000 OHM 5% 1/4W	01121	CB 2025
A23R6	0683-1025		R:FXD COMP 1000 OHM 5% 1/4W	01121	CB 1025
A23R7	0683-4705		R:FXD COMP 47 OHM 5% 1/4W	01121	CB 4705
A23R8	0683-1035		R:FXD COMP 10K OHM 5% 1/4W	01121	CB 1035
A23R9	0683-8215		R:FXD COMP 820 OHM 5% 1/4W	01121	CB 8215
A23R10	0683-2025		R:FXD COMP 2000 OHM 5% 1/4W	01121	CB 2025
A23R11	0683-1025		R:FXD COMP 1000 OHM 5% 1/4W	01121	CB 1025
A23R12	0683-1025		R:FXD COMP 1000 OHM 5% 1/4W	01121	CB 1025
A23R13	0683-3015		R:FXD COMP 300 OHM 5% 1/4W	01121	CB 3015
A23R14	0683-8215		R:FXD COMP 820 OHM 5% 1/4W	01121	CB 8215
A23R15	0683-3015		R:FXD COMP 300 OHM 5% 1/4W	01121	CB 3015
A23R16			NOT ASSIGNED		
A23R17	0683-1025		R:FXD COMP 1000 OHM 5% 1/4W	01121	CB 1025
A23R18	0683-1025		R:FXD COMP 1000 OHM 5% 1/4W	01121	CB 1025
A23R19	0683-1025		R:FXD COMP 1000 OHM 5% 1/4W	01121	CB 1025
A23R20	0683-1025		R:FXD COMP 1000 OHM 5% 1/4W	01121	CB 1025
A23K21	0683-1025		R:FXD COMP 1000 OHM 5% 1/4W	01121	CB 1025
A23R22	0683-1025		R:FXD COMP 1000 OHM 5% 1/4W	01121	CB 1025
A23R23	0683-2025		R:FXD COMP 2000 OHM 5% 1/4W	01121	CB 2025
A23R24	0683-1825	1	R:FXD COMP 1800 OHM 5% 1/4W	01121	CB 1825
A23R25	0683-1025		R:FXD COMP 1000 OHM 5% 1/4W	01121	CB 1025
A23R26	0683-3325		R:FXD COMP 3300 OHM 5% 1/4W	01121	CB 3325
A23K27	0698-4308	3	R:FXD MET FLM 16.9K OHM 1% 1/8W	28480	0698-4308
A23R28	0757-0415		R:FXD MET FLM 475 OHM 1% 1/8W	28480	0757-0415
A23K29	0683-2035		R:FXD COMP 20K OHM 5% 1/4W	01121	CB 2035
A23R30	0683-5125		R:FXD COMP 5100 OHM 5% 1/4W	01121	CB 5125
A23R31	0683-5125		R:FXD COMP 5100 OHM 5% 1/4W	01121	CB 5125

See introduction to this section for ordering information

Table 6-1. Replaceable Parts(Cont'd)

Reference Designation	HP Part Number	Qty	Description	Mfr Code	Mfr Part Number
A23K32	0683-2035		R:FXD COMP 20K OHM 5% 1/4W	01121	CB 2035
A23K33	0683-1135		R:FXD COMP 11K OHM 5% 1/4W	01121	CB 1135
A23K34	0698-4308		R:FXD MET FLM 16.9K OHM 1% 1/8W	28480	0698-4308
A23K35	0683-2025		R:FXD COMP 2000 OHM 5% 1/4W	01121	CB 2025
A23K36	0683-3015		R:FXD COMP 300 OHM 5% 1/4W	01121	CB 3015
A23K37	0683-4725		R:FXD COMP 4700 OHM 5% 1/4W	01121	CB 4725
A24	03330-66520	1	PC ASSY:SL1 MIX	28480	03330-66520
A24C1	0150-0093		C:FXD CER 0.01 UF +80-20% 100VDCW	72982	801-K800011
A24C2	0150-0093		C:FXD CER 0.01 UF +80-20% 100VDCW	72982	801-K800011
A24C3	0150-0093		C:FXD CER 0.01 UF +80-20% 100VDCW	72982	801-K800011
A24C4	0160-0335	1	C:FXD MICA 91 PF 1%	28480	0160-0335
A24C5	0140-0210		C:FXD MICA 270 PF 5%	28480	0140-0210
A24C6	0150-0093		C:FXD CER 0.01 UF +80-20% 100VDCW	72982	801-K800011
A24C7	0180-1746		C:FXD ELECT 15 UF 10% 20VDCW	28480	0180-1746
A24C8	0180-1746		C:FXD ELECT 15 UF 10% 20VDCW	28480	0180-1746
A24C9	0180-1746		C:FXD ELECT 15 UF 10% 20VDCW	28480	0180-1746
A24IC1	1858-0019		TSTR ARRAY:DUAL INDEP. DIFFERENTIAL	02735	CA 3054
A24L1	9140-0210		COIL/CHOKE 100 UH 5%	82142	15-1315-12J
A24L2	9100-1627		COIL/CHOKE 39 UH 5%	82142	15-1315-2J
A24L3	9140-0107		COIL:FXD RF 27 UH 10%	99800	1840-38
A24L4	9140-0107		COIL:FXD RF 27 UH 10%	99800	1840-38
A24J1	1854-0019		TSTR:SI NPN	28480	1854-0019
A24K1	0698-4453	3	R:FXD FLM 402 OHM 1% 1/8W	28480	0698-4453
A24R2	0698-4453		R:FXD FLM 402 OHM 1% 1/8W	28480	0698-4453
A24R3	0757-0407	3	R:FXD MET FLM 200 OHM 1% 1/8W	28480	0757-0407
A24K4	0757-0407		R:FXD MET FLM 200 OHM 1% 1/8W	28480	0757-0407
A24K5	0757-0277	37	R:FXD MET FLM 49.9 OHM 1% 1/8W	28480	0757-0277
A24R6	0757-0277		R:FXD MET FLM 49.9 OHM 1% 1/8W	28480	0757-0277
A24R7	0698-4425	1	R:FXD FLM 1.54K OHM 1% 1/8W	28480	0698-4425
A24R8	0757-0442		R:FXD MET FLM 10.0K OHM 1% 1/8W	28480	0757-0442
A24K9	0698-3279		R:FXD MET FLM 4990 OHM 1% 1/8W	28480	0698-3279
A24R10	0757-0349	11	R:FXD MET FLM 22.6K OHM 1% 1/8W	28480	0757-0349
A24K11	0698-3511	2	R:FXD FLM 665 OHM 1% 1/8W	28480	0698-3511
A24K12	0757-0435	1	R:FXD FLM 3920 OHM 1% 1/8W	28480	0757-0435
A24R13	0757-0403	1	R:FXD MET FLM 121 OHM 1% 1/8W	28480	0757-0403
A24K14	0757-0277		R:FXD MET FLM 49.9 OHM 1% 1/8W	28480	0757-0277
A24R15	0757-0407		R:FXD MET FLM 200 OHM 1% 1/8W	28480	0757-0407
A25	03330-66521	1	PC ASSY:SL1/VTJ BOARD	28480	03330-66521
A25C1	0180-0229		C:FXD ELECT 33 UF 10% 10VDCW	28480	0180-0229
A25C2			NOT ASSIGNED		
A25C3			NOT ASSIGNED		
A25C4			NOT ASSIGNED		
A25C5	0170-0079		C:FXD MY 0.047UF 20% 50VDCW	84411	STYLE 3 TYPE 601PE
A25C6	0150-0093		C:FXD CER 0.01 UF +80-20% 100VDCW	72982	801-K800011
A25C7	0140-0200		C:FXD MICA 390 PF 5%	72136	RDM15F391-J3C
A25C8	0140-0191	2	C:FXD MICA 56 PF 5% 300VDCW	19701	RDM15E560J 300V
A25C9	0140-0203		C:FXD MICA 30 PF 5%	28480	0140-0203
A25C10	0150-0093		C:FXD CER 0.01 UF +80-20% 100VDCW	72982	801-K800011
A25C11	0150-0093		C:FXD CER 0.01 UF +80-20% 100VDCW	72982	801-K800011
A25C12	0150-0093		C:FXD CER 0.01 UF +80-20% 100VDCW	72982	801-K800011
A25C13	0150-0093		C:FXD CER 0.01 UF +80-20% 100VDCW	72982	801-K800011
A25C14	0150-0093		C:FXD CER 0.01 UF +80-20% 100VDCW	72982	801-K800011
A25C15	0150-0093		C:FXD CER 0.01 UF +80-20% 100VDCW	72982	801-K800011
A25C16	0150-0093		C:FXD CER 0.01 UF +80-20% 100VDCW	72982	801-K800011
A25C17	0150-0093		C:FXD CER 0.01 UF +80-20% 100VDCW	72982	801-K800011
A25C18	0150-0093		C:FXD CER 0.01 UF +80-20% 100VDCW	72982	801-K800011
A25C19	0150-0093		C:FXD CER 0.01 UF +80-20% 100VDCW	72982	801-K800011
A25C20	0150-0093		C:FXD CER 0.01 UF +80-20% 100VDCW	72982	801-K800011
A25C21	0150-0093		C:FXD CER 0.01 UF +80-20% 100VDCW	72982	801-K800011
A25C22	0150-0093		C:FXD CER 0.01 UF +80-20% 100VDCW	72982	801-K800011
A25C23	0180-1746		C:FXD ELECT 15 UF 10% 20VDCW	28480	0180-1746
A25C24	0180-1746		C:FXD ELECT 15 UF 10% 20VDCW	28480	0180-1746
A25C25	0180-0291		C:FXD ELECT 1.0 UF 10% 35VDCW	56289	150D105X9035A2-DYS
A25C26	0180-1735		C:FXD ELECT 0.22 UF 10% 35VDCW	28480	0180-1735
A25C27	0150-0093		C:FXD CER 0.01 UF +80-20% 100VDCW	72982	801-K800011
A25C28	0150-0093		C:FXD CER 0.01 UF +80-20% 100VDCW	72982	801-K800011
A25CR1	1901-0040		DIODE:SILICON 30MA 30WV	07263	FDG1088
A25CR2	1901-0040		DIODE:SILICON 30MA 30WV	07263	FDG1088
A25CR3	1902-0025		DIODE,BREAKDOWN:10.0V 5% 400 MW	28480	1902-0025
A25CR4	1901-0040		DIODE:SILICON 30MA 30WV	07263	FDG1088
A25CR5	0122-0059		DIODE:VOLTAGE VARIABLE CAPACITANCE	28480	0122-0059
A25CR6	0122-0059		DIODE:VOLTAGE VARIABLE CAPACITANCE	28480	0122-0059
A25IC1	1826-0043		IC:LINEAR OPERATIONAL AMPLIFIER	28480	1826-0043
A25IC2	1826-0043		IC:LINEAR OPERATIONAL AMPLIFIER	28480	1826-0043
A25L1			NOT ASSIGNED		

See introduction to this section for ordering information

Table 6-1. Replaceable Parts(Cont'd)

Reference Designation	HP Part Number	Qty	Description	Mfr Code	Mfr Part Number
A25L2	9100-3312	1	INDUCTOR:VAR 1.00 UH 10%	28480	9100-3312
A25L3	9140-0107		COIL:FXD RF 27 UH 10%	93800	1340-38
A25L4	9140-0107		COIL:FXD RF 27 UH 10%	99800	1340-38
A25L5	9140-0210		COIL/CHOKE 100 UH 5%	82142	15-1315-12J
A25L6	9100-1617		COIL/CHOKE:3.90 UH 10%	28480	9100-1617
A25Q1	1853-0010		TSTR:SI PNP(SELECTED FROM 2N3251)	28480	1953-0010
A25Q2	1854-0404	TSTR:SI NPN	28480	1354-0404	
A25Q3	1854-0354	TSTR:SI NPN	28480	1354-0354	
A25Q4	1853-0010	TSTR:SI PNP(SELECTED FROM 2N3251)	28480	1853-0010	
A25Q5	1855-0081	TSTR:SI FET	80131	2N5245	
A25Q6	1853-0010	TSTR:SI PNP(SELECTED FROM 2N3251)	28480	1853-0010	
A25Q7	1853-0010	TSTR:SI PNP(SELECTED FROM 2N3251)	28480	1853-0010	
A25Q8	1855-0081	TSTR:SI FET	80131	2N5245	
A25Q9	1854-0404	TSTR:SI NPN	28480	1854-0404	
A25Q10	1854-0345	TSTR:SI NPN	80131	2N5179	
A25Q11	1854-0345	TSTR:SI NPN	80131	2N5179	
A25Q12	1854-0019	TSTR:SI NPN	28480	1854-0019	
A25Q13	1854-0019	TSTR:SI NPN	28480	1354-0019	
A25Q14	1854-0019	TSTR:SI NPN	28480	1854-0019	
A25Q15	1854-0019	TSTR:SI NPN	28480	1854-0019	
A25Q16	1854-0019	TSTR:SI NPN	28480	1854-0019	
A25Q17	1854-0019	TSTR:SI NPN	28480	1354-0019	
A25Q18	1854-0019	TSTR:SI NPN	28480	1854-0019	
A25Q19	1854-0345	TSTR:SI NPN	80131	2N5179	
A25K1	0757-0289	R:FXD MET FLM 13.3K OHM 1% 1/8W	28480	0757-0289	
A25K2	2100-2522	R:VAR CERMET 10K OHM 10% LIN 1/2W	28480	2100-2522	
A25K3	0757-0442	R:FXD MET FLM 10.0K OHM 1% 1/8W	28480	0757-0442	
A25K4	2100-2516	R:VAR CERMET 100K OHM 10% LIN 1/2W	28480	2100-2516	
A25K5	0757-0442	R:FXD MET FLM 10.0K OHM 1% 1/8W	28480	0757-0442	
A25K6	2100-2522	R:VAR CERMET 10K OHM 10% LIN 1/2W	28480	2100-2522	
A25R7	0757-0442	R:FXD MET FLM 10.0K OHM 1% 1/8W	28480	0757-0442	
A25R8	2100-2516	R:VAR CERMET 100K OHM 10% LIN 1/2W	28480	2100-2516	
A25R9	0757-0442	R:FXD MET FLM 10.0K OHM 1% 1/8W	28480	0757-0442	
A25R10	0683-1555	R:FXD COMP 1.5 MEGOHM 5% 1/4W	01121	CB 1555	
A25R11	0698-6719	R:FXD FLM 15K OHM 1% 1/8W	28480	0698-6719	
A25R12	0598-8235	R:FXD FLM 9.31K OHM 1% 1/8W	28480	0698-8235	
A25R13	0698-3279	R:FXD MET FLM 4990 OHM 1% 1/8W	28480	0698-3279	
A25K14	2100-3056	R:VAR CERMET 5K OHM 10% TYPE P 3/4W	28480	2100-3056	
A25R15	0698-3279	R:FXD MET FLM 4990 OHM 1% 1/8W	28480	0698-3279	
A25K16	0757-0401	R:FXD MET FLM 100 OHM 1% 1/8W	28480	0757-0401	
A25R17	0698-3279	R:FXD MET FLM 4990 OHM 1% 1/8W	28480	0698-3279	
A25R18	0757-0401	R:FXD MET FLM 100 OHM 1% 1/8W	28480	0757-0401	
A25R19	0757-0401	R:FXD MET FLM 100 OHM 1% 1/8W	28480	0757-0401	
A25R20	0757-0469	R:FXD MET FLM 150 K OHM 1% 1/8W	28480	0757-0469	
A25K21	0757-0430	R:FXD MET FLM 2.21K OHM 1% 1/8W	28480	0757-0430	
A25R22	0698-4486	R:FXD MET FLM 24.9K OHM 1% 1/8W	28480	0698-4486	
A25R23	0757-0449	R:FXD FLM 20K OHM 1% 1/8W	28480	0757-0449	
A25R24	0698-3228	R:FXD MET FLM 49.9K OHM 1% 1/8W	28480	0698-3228	
A25R25	0757-0272	R:FXD FLM 52.3K OHM 1% 1/8W	28480	0757-0272	
A25K26	0698-4123	R:FXD MET FLM 499 OHM 1% 1/8W	28480	0698-4123	
A25R27	0757-0433	R:FXD MET FLM 3.32K OHM 1% 1/8W	28480	0757-0433	
A25R28	0698-4512	R:FXD FLM 88.7K OHM 1% 1/8W	28480	0698-4512	
A25R29	0698-4470	R:FXD FLM 6.98K OHM 1% 1/8W	28480	0698-4470	
A25R30	0757-0442	R:FXD MET FLM 10.0K OHM 1% 1/8W	28480	0757-0442	
A25R31	0757-0427	R:FXD MET FLM 1.5K OHM 1% 1/8W	28480	0757-0427	
A25R32	0757-0442	R:FXD MET FLM 10.0K OHM 1% 1/8W	28480	0757-0442	
A25R33	0757-0283	R:FXD FLM 2K OHM 1% 1/8W	24546	C4-1/8-TO-2001-F	
A25R34	0757-0401	R:FXD MET FLM 100 OHM 1% 1/8W	28480	0757-0401	
A25R35	0757-0442	R:FXD MET FLM 10.0K OHM 1% 1/8W	28480	0757-0442	
A25R36	0757-0277	R:FXD MET FLM 49.9 OHM 1% 1/8W	28480	0757-0277	
A25R37	0698-4308	R:FXD MET FLM 16.9K OHM 1% 1/8W	28480	0698-4308	
A25R38	0757-0280	R:FXD MET FLM 1K OHM 1% 1/8W	28480	0757-0280	
A25R39	0698-3572	R:FXD FLM 60.4K OHM 1% 1/8W	28480	0698-3572	
A25R40	0757-0283	R:FXD MET FLM 2.00K OHM 1% 1/8W	28480	0757-0283	
A25R41	0757-0277	R:FXD MET FLM 49.9 OHM 1% 1/8W	28480	0757-0277	
A25R42	0698-3558	R:FXD MET FLM 4.02K OHM 1% 1/8W	28480	0698-3558	
A25R43	0757-0277	R:FXD MET FLM 49.9 OHM 1% 1/8W	28480	0757-0277	
A25R44	0683-4725	R:FXD COMP 4700 OHM 5% 1/4W	01121	CB 4725	
A25R45	0683-4705	R:FXD COMP 47 OHM 5% 1/4W	01121	CB 4705	
A25R46	0683-4705	R:FXD COMP 47 OHM 5% 1/4W	01121	CB 4705	
A25R47	0683-4725	R:FXD COMP 4700 OHM 5% 1/4W	01121	CB 4725	
A25R48	0683-1015	R:FXD COMP 100 OHM 5% 1/4W	01121	CB 1015	
A25R49	0683-4725	R:FXD COMP 4700 OHM 5% 1/4W	01121	CB 4725	
A25R50	0683-4705	R:FXD COMP 47 OHM 5% 1/4W	01121	CB 4705	
A25R51	0683-6815	R:FXD COMP 680 OHM 5% 1/4W	01121	CB 6815	

See introduction to this section for ordering information

Table 6-1. Replaceable Parts(Cont'd)

Reference Designation	HP Part Number	Qty	Description	Mfr Code	Mfr Part Number	
A25R52	0683-6825	1	R:FXD COMP 6800 OHM 5% 1/4W	01121	CB 6825	
A25R53	0698-3437		R:FXD MET FLM 133 OHM 1% 1/8W	28480	0698-3437	
A25R54	0583-4705		R:FXD COMP 47 OHM 5% 1/4W	01121	CB 4705	
A25R55	0683-4725		R:FXD COMP 4700 OHM 5% 1/4W	01121	CB 4725	
A25R56	0683-1015		R:FXD COMP 100 OHM 5% 1/4W	01121	CB 1015	
A25R57	0683-4725		R:FXD COMP 4700 OHM 5% 1/4W	01121	CB 4725	
A25R58	0583-4705		R:FXD COMP 47 OHM 5% 1/4W	01121	CB 4705	
A25R59	0683-2215		R:FXD COMP 220 OHM 5% 1/4W	01121	CB 2215	
A25R60	0683-4725		R:FXD COMP 4700 OHM 5% 1/4W	01121	CB 4725	
A25R61	0683-2215		R:FXD COMP 220 OHM 5% 1/4W	01121	CB 2215	
A25R62	0683-4705	1	R:FXD COMP 47 OHM 5% 1/4W	01121	CB 4705	
A25R63	0683-2225		R:FXD COMP 2.2K OHM 5% 1/4W	01121	CB 2225	
A25R64	0683-1015		R:FXD COMP 100 OHM 5% 1/4W	01121	CB 1015	
A25R65	0683-4725		R:FXD COMP 4700 OHM 5% 1/4W	01121	CB 4725	
A25R66	0683-6805		R:FXD COMP 68 OHM 5% 1/4W	01121	CB 6805	
A25R67	0683-3915		R:FXD COMP 390 OHM 5% 1/4W	01121	CB 3915	
A25R68	0757-0410		R:FXD MET FLM 301 OHM 1% 1/8W	28480	0757-0410	
A25R69	0698-3572		R:FXD FLM 60.4K OHM 1% 1/8W	28480	0698-3572	
A25R70	0757-0442		R:FXD MET FLM 10.0K OHM 1% 1/8W	28480	0757-0442	
A25R71	0683-1015		R:FXD COMP 100 OHM 5% 1/4W	01121	CB 1015	
A25R72	0757-0442		R:FXD MET FLM 10.0K OHM 1% 1/8W	28480	0757-0442	
A25R73	0757-0280		R:FXD MET FLM 1K OHM 1% 1/8W	28480	0757-0280	
A25SW1	3101-1341		SWITCH:SLIDE SPDT 0.5A 125V AC/DC	79727	C-111-0004	
A26 (B ONLY)	03330-66522		PC ASSY:AMPLITUDE/R BOARD	28480	03330-66522	
A26C1	0160-0157		6	C:FXD MY 0.0047 UF 10% 200VDCW	56289	192P47292-PTS
A26C2	0160-0207	3	C:FXD MYLAR 0.01UF 5% 200VDCW	28480	0160-0207	
A26C3	0150-0084		14	C:FXD CER 0.1 UF +80-20% 100VDCW	72982	8131-100-651-104Z
A26C4	0160-0496		1	C:FXD MICA 22000 PF 1% 100VDCW	00853	ROM30F223F1C
A26C5	0170-0055		1	C:FXD MY 0.1UF 20% 200VDCW	56289	192P10402
A26C6				NOT ASSIGNED		
A26C7	0180-1746		C:FXD ELECT 15 UF 10% 20VDCW	28480	0180-1746	
A26C8			NOT ASSIGNED			
A26C9			NOT ASSIGNED			
A26C10			NOT ASSIGNED			
A26C11	0180-1746			C:FXD ELECT 15 UF 10% 20VDCW	28480	0180-1746
A26C12		1	NOT ASSIGNED			
A26C13	0180-1746			C:FXD ELECT 15 UF 10% 20VDCW	28480	0180-1746
A26CR1	1901-0040			DIODE:SILICON 30MA 30WV	07263	FDG1088
A26CR2	1901-0040			DIODE:SILICON 30MA 30WV	07263	FDG1088
A26CR3	1902-0692			DIODE:TC REFERENCE 6.3V 1%	28480	1902-0692
A26CR4	1901-0040	1	DIODE:SILICON 30MA 30WV	07263	FDG1088	
A26CR5	1902-0048			DIODE:BREAKDOWN 6.81V 5%	04713	SZ10939-134
A26IC1	1820-0782			IC:TTL TRIPLE 3-INPT NOR GATE	01295	SN7427N
A26IC2	1820-0282			IC:TTL QUAD 2-INPT EXCL. OR GATE	01295	SN7486N
A26IC3	1820-0583		2	IC:TTL LP QUAD 2-INPT NAND GATE	12040	DM74L00N
A26IC4	1820-0322	3	IC:TTL DECADE DIVIDER	56289	N8280A	
A26IC5	1820-0322			IC:TTL DECADE DIVIDER	56289	N8280A
A26IC6	1820-0322			IC:TTL DECADE DIVIDER	56289	N8280A
A26IC7	1820-0595	1	IC:TTL LP DUAL J-K MASTER SLAVE F/F	12040	DM74L73N	
A26IC8	1820-0207			IC:TTL MONOSTABLE MULTIVIBRATOR	28480	1820-0207
A26IC9	1820-0207		IC:TTL MONOSTABLE MULTIVIBRATOR	28480	1820-0207	
A26IC10	1826-0043			IC:LINEAR OPERATIONAL AMPLIFIER	28480	1826-0043
A26IC11	1826-0043			IC:LINEAR OPERATIONAL AMPLIFIER	28480	1826-0043
A26IC12	1826-0043			IC:LINEAR OPERATIONAL AMPLIFIER	28480	1826-0043
A26L1	9140-0107			COIL:FXD RF 27 UH 10%	99800	1840-38
A26L2	9100-1618		COIL:MOLDED CHOKE 5.60 UH	28480	9100-1618	
A26L3	9140-0107			COIL:FXD RF 27 UH 10%	99800	1840-38
A26Q1	1853-0010			TSTR:SI PNP(SELECTED FROM 2N3251)	28480	1853-0010
A26Q2	1853-0010			TSTR:SI PNP(SELECTED FROM 2N3251)	28480	1853-0010
A26Q3	1853-0010			TSTR:SI PNP(SELECTED FROM 2N3251)	28480	1853-0010
A26Q4	1855-0386	3	TSTR:FET N-CHANNEL	80131	2N4392	
A26Q5	1854-0404			TSTR:SI NPN	28480	1854-0404
A26Q6	1854-0351		3	TSTR:SI NPN	04713	2N3904
A26Q7	1854-0351		TSTR:SI NPN	04713	2N3904	
A26Q8	1854-0351			TSTR:SI NPN	04713	2N3904
A26Q9	1855-0386	9	TSTR:FET N-CHANNEL	80131	2N4392	
A26Q10	1853-0010			TSTR:SI PNP(SELECTED FROM 2N3251)	28480	1853-0010
A26Q11	1855-0386			TSTR:FET N-CHANNEL	80131	2N4392
A26R1	0757-0437			R:FXD MET FLM 4750 OHM 1% 1/8W	28480	0757-0437
A26R2	0757-0427			R:FXD MET FLM 1.5K OHM 1% 1/8W	28480	0757-0427
A26R3	0757-0442		R:FXD MET FLM 10.0K OHM 1% 1/8W	28480	0757-0442	
A26R4	0757-0430		R:FXD MET FLM 2.21K OHM 1% 1/8W	28480	0757-0430	
A26R5	0757-0427		R:FXD MET FLM 1.5K OHM 1% 1/8W	28480	0757-0427	
A26R6	0757-0430		R:FXD MET FLM 2.21K OHM 1% 1/8W	28480	0757-0430	
A26R7	0757-0449		R:FXD FLM 20K OHM 1% 1/8W	28480	0757-0449	

See introduction to this section for ordering information

Table 6-1. Replaceable Parts(Cont'd)

Reference Designation	HP Part Number	Qty	Description	Mfr Code	Mfr Part Number
A26K8	0757-0449	2	R:FXD FLM 20K OHM 1% 1/8W	23480	0757-0449
A26R9	0698-4484		R:FXD FLM 19.1K OHM 1% 1/8W	28480	0698-4484
A26R10	0757-0430		R:FXD MET FLM 2.21K OHM 1% 1/8W	28480	0757-0430
A26R11	0698-4484		R:FXD FLM 19.1K OHM 1% 1/8W	28480	0698-4484
A26R12	0757-0430		R:FXD MET FLM 2.21K OHM 1% 1/8W	28480	0757-0430
A26R13	0757-0430	2	R:FXD MET FLM 2.21K OHM 1% 1/8W	23480	0757-0430
A26R14	0757-0454		R:FXD MET FLM 33.2K OHM 1% 1/8W	28480	0757-0454
A26R15	0698-6670		R:FXD MET FLM 1K OHM 0.5% 1/8W	28480	0698-6670
A26R16	0698-8026		R:FXD FLM 1.61K OHM 0.5% 1/8W	28480	0698-8026
A26R17	2100-3095		R:VAR CERMET 200 OHM 10% TYPE P 3/4W	28480	2100-3095
A26R18	0757-0420	1	R:FXD MET FLM 750 OHM 1% 1/8W	28480	0757-0420
A26R19	0757-0274		R:FXD MET FLM 1.21K OHM 1% 1/8W	28480	0757-0274
A26R20	0698-8027		R:FXD FLM 19.3K OHM 0.5% 1/8W	28480	0698-8027
A26R21	0757-0280		R:FXD MET FLM 1K OHM 1% 1/8W	28480	0757-0280
A26R22	2100-3154		R:VAR CERMET 1000 OHM 10% TYPE P 3/4W	28480	2100-3154
A26R23	0757-0442	1	R:FXD MET FLM 10.0K OHM 1% 1/8W	28480	0757-0442
A26R24	0698-4205		R:FXD FLM 21K OHM 1% 1/8W	28480	0698-4205
A26R25	0698-3228		R:FXD MET FLM 49.9K OHM 1% 1/8W	28480	0698-3228
A26R26	0757-0459		R:FXD MET FLM 56.2K OHM 1% 1/8W	28480	0757-0459
A26R27	0757-0280		R:FXD MET FLM 1K OHM 1% 1/8W	28480	0757-0280
A26R28		1	NOT ASSIGNED		
A26R29	0757-0280		R:FXD MET FLM 1K OHM 1% 1/8W	28480	0757-0280
A27 Δ13	03330-66532		PC ASSY: SL3 MIX/PH. DET. (IDENTICAL TO A21)	28480	03330-66532
A28 (B ONLY)	03330-66523		PC ASSY:AMPLITUDE/D BOARD	28480	03330-66523
A28C1			NOT ASSIGNED		
A28C2	0160-3183	1	C:FXD MY 0.47 UF 20% 50VDCW	84411	HEW 101
A28C3	0140-0191		C:FXD MICA 56 PF 5% 300VDCW	19701	RDML5E560J 300V
A28C4	0160-0298		C:FXD MY 0.0015 UF 10% 200VDCW	56289	192P15292-PTS
A28C5	0160-0301		C:FXD MY 0.012 UF 10% 200VDCW	56289	192P12392-PTS
A28C6	0170-0079		C:FXD MY 0.047UF 20% 50VDCW	84411	STYLE 3 TYPE 601PE
A28C7	0180-0374	6	C:FXD TANT. 10 UF 10% 20VDCW	56289	150D106X902082-DYS
A28C8	0160-0301		C:FXD MY 0.012 UF 10% 200VDCW	56289	192P12392-PTS
A28C9	0160-3077		C:FXD MY 0.027 UF 10% 100VDCW	56289	225P2739WB1-PWM
A28C10	0160-3077		C:FXD MY 0.027 UF 10% 100VDCW	56289	225P2739WB1-PWM
A28C11	0180-0197		C:FXD ELECT 2.2 UF 10% 20VDCW	56289	150D225X9020A2-DYS
A28C12	0160-0207	2	C:FXD MYLAR 0.01UF 5% 200VDCW	28480	0160-0207
A28C13	0160-2611		C:FXD MY 1 UF 10% 50VDCW	84411	HEW 101
A28C14	0160-2611		C:FXD MY 1 UF 10% 50VDCW	84411	HEW 101
A28C15	0160-0207		C:FXD MYLAR 0.01UF 5% 200VDCW	28480	0160-0207
A28C16	0180-1746		C:FXD ELECT 15 UF 10% 20VDCW	28480	0180-1746
A28C17	0180-1746	1	C:FXD ELECT 15 UF 10% 20VDCW	28480	0180-1746
A28C18	0180-1746		C:FXD ELECT 15 UF 10% 20VDCW	28480	0180-1746
A28C19	0180-0060		C:FXD AL ELECT 200 UF +75-10% 3VDCW	56289	30D2076003CC2-DS4
A28CR1	1901-0040		DIODE:SILICON 30MA 30WV	07263	FDG1088
A28CR2	1901-0040		DIODE:SILICON 30MA 30WV	07263	FDG1088
A28CR3	1901-0040	2	DIODE:SILICON 30MA 30WV	07263	FDG1088
A28CR4	1901-0040		DIODE:SILICON 30MA 30WV	07263	FDG1088
A28CR5	1902-0057		DIODE BREAKDOWN:6.49V	28480	1902-0057
A28CR6	1901-0040		DIODE:SILICON 30MA 30WV	07263	FDG1088
A28CR7	1901-0040		DIODE:SILICON 30MA 30WV	07263	FDG1088
A28CR8	1901-0053	1	DIODE:SILICON 30VDCW	07263	FD3444
A28CR9	1902-0057		DIODE BREAKDOWN:6.49V	28480	1902-0057
A28CR10	1901-0040		DIODE:SILICON 30MA 30WV	07263	FDG1088
A28IC1	1826-0043		IC:LINEAR OPERATIONAL AMPLIFIER	28480	1826-0043
A28IC2	1826-0043		IC:LINEAR OPERATIONAL AMPLIFIER	28480	1826-0043
A28IC3	1820-0203	6	IC:LINEAR OPERATIONAL AMPLIFIER	28480	1826-0203
A28IC4	1820-0207		IC:TTL MONOSTABLE MULTIVIBRATOR	28480	1820-0207
A28IC5	1826-0043		IC:LINEAR OPERATIONAL AMPLIFIER	28480	1826-0043
A28K1	0490-0963		RELAY:MULTI-REED	28480	0490-0963
A28K2	0490-1015		RELAY:REED COIL 10 VA 250V	15636	R2731-2
A28L1	9140-0107	4	COIL:FXD RF 27 UH 10%	99800	1840-38
A28L2	9140-0107		COIL:FXD RF 27 UH 10%	99800	1840-38
A28L3	9100-1618		COIL:MOLDED CHOKE 5.60 UH	28480	9100-1618
A28P1	1250-1195		CONNECTOR:RF SUB-MINIATURE SERIES	98291	52-053-0000
A28Q1	1854-0404		TSTR:SI NPN	28480	1854-0404
A28Q2	1854-0394	2	TSTR:SI NPN	28480	1854-0394
A28Q3	1855-0368		TSTR:FET SI NPN N-CHANNEL	28480	1855-0368
A28Q4	1854-0515		TSTR:SI NPN, DUAL	28480	1854-0515
A28Q5	1854 0019		TSTR:SI NPN	28480	1854-0019
A28Q6	1854-0210		TSTR:SI NPN	80131	2N2222
A28Q7	1854-0404	3	TSTR:SI NPN	28480	1854-0404
A28Q8	1855-0368		TSTR:FET SI NPN N-CHANNEL	28480	1855-0368
A28Q9	1854-0210		TSTR:SI NPN	80131	2N2222
A28Q10	1855-0368		TSTR:FET SI NPN N-CHANNEL	28480	1855-0368
A28Q11	1855-0368		TSTR:FET SI NPN N-CHANNEL	28480	1855-0368

See introduction to this section for ordering information

Table 6-1. Replaceable Parts(Cont'd)

Reference Designation	HP Part Number	Qty	Description	Mfr Code	Mfr Part Number
A28Q12	1854-0404		TSTR:SI NPN	28480	1854-0404
A28Q13	1853-0010		TSTR:SI PNP(SELECTED FROM 2N3251)	28480	1853-0010
A28R1	0757-0446		R:FXD MET FLM 15.0K OHM 1% 1/8W	28480	0757-0446
A28R2	0757-0280		R:FXD MET FLM 1K OHM 1% 1/8W	28480	0757-0280
A28R3	0757-0280		R:FXD MET FLM 1K OHM 1% 1/8W	28480	0757-0280
A28R4	0698-4479		R:FXD FLM 14K OHM 1% 1/8W	28480	0698-4479
A28R5	0757-0452	6	R:FXD MET FLM 27.4K OHM 1% 1/8W	28480	0757-0452
A28R6	0757-0419	1	R:FXD MET FLM 681 OHM 1% 1/8W	28480	0757-0419
A28R7	0757-0406	1	R:FXD MET FLM 182 OHM 1% 1/8W	28480	0757-0406
A28R8	0684-4751	6	R:FXD COMP 4.7 MEGOHM 10% 1/4W	01121	CB 4751
A28R9	0698-4499	1	R:FXD FLM 54.9K OHM 1% 1/8W	28480	0698-4499
A28R10	0664-2251	1	R:FXD COMP 2.2 MEGOHM 10% 1/4W	01121	CB 2251
A28R11			0 OHM, FACTORY SELECTED PART		
A28R12	2100-3056		R:VAR CERMET 5K OHM 10% TYPE P 3/4W	28480	2100-3056
A28R13			0 OHM, FACTORY SELECTED PART		
A28R14	0698-8004	2	R:FXD MET FLM 200K OHM 0.1% 0.1W	28480	0698-8004
A28R15	0698-8004		R:FXD MET FLM 200K OHM 0.1% 0.1W	28480	0698-8004
A28R16	0757-0472	2	R:FXD MET FLM 200K OHM 1% 1/8W	28480	0757-0472
A28R17	0757-0472		R:FXD MET FLM 200K OHM 1% 1/8W	28480	0757-0472
A28R18	0757-0457	3	R:FXD MET FLM 47.5K OHM 1% 1/8W	28480	0757-0457
A28R19	0757-0457		R:FXD MET FLM 47.5K OHM 1% 1/8W	28480	0757-0457
A28R20	0698-4530	1	R:FXD FLM 232K OHM 1% 1/8W	28480	0698-4530
A28R21	0698-4462	1	R:FXD FLM 768 OHM 1% 1/8W	28480	0698-4462
A28R22	0757-0280		R:FXD MET FLM 1K OHM 1% 1/8W	28480	0757-0280
A28R23	0757-0728	1	R:FXD MET FLM 619 OHM 1% 1/4W	28480	0757-0728
A28R24	0757-0428	1	R:FXD MET FLM 1.62K OHM 1% 1/8W	28480	0757-0428
A28R25	0757-0427		R:FXD MET FLM 1.5K OHM 1% 1/8W	28480	0757-0427
A28R26	0757-0454		R:FXD MET FLM 33.2K OHM 1% 1/8W	28480	0757-0454
A28R27	0757-0440		R:FXD MET FLM 7.50K OHM 1% 1/8W	28480	0757-0440
A28R28	0698-8005	2	R:FXD MET FLM 75 OHM 0.1% 0.1W	28480	0698-8005
A28R29	0698-8007	1	R:FXD MET FLM 7.054K OHM 0.1% 0.1W	28480	0698-8007
A28R30	2100-3122	1	R:VAR CERMET 100 OHM 10% 3/4W	28480	2100-3122
A28R31	0757-0274		R:FXD MET FLM 1.21K OHM 1% 1/8W	28480	0757-0274
A28R32	0698-8006	1	R:FXD MET FLM 1.772K OHM 0.1% 0.1W	28480	0698-8006
A28R33	2100-3054	2	R:VAR CERMET 50K OHM 10% 3/4W	28480	2100-3054
A28R34	0698-3582	1	R:FXD MET FLM 41.2K OHM 1% 1/8W	28480	0698-3582
A28R35	0698-3262	3	R:FXD MET FLM 40.2 OHM 1% 1/8W	28480	0698-3262
A28R36	0698-3228		R:FXD MET FLM 49.9K OHM 1% 1/8W	28480	0698-3228
A28R37	0684-1061	1	R:FXD COMP 10 MEGOHM 10% 1/4W	01121	CB 1061
A28R38	0757-0280		R:FXD MET FLM 1K OHM 1% 1/8W	28480	0757-0280
A28R39	0698-3160	1	R:FXD MET FLM 31.6K OHM 1% 1/8W	28480	0698-3160
A28R40	0598-3226	3	R:FXD MET FLM 6.49K OHM 1% 1/8W	28480	0698-3226
A28R41	0684-4751		R:FXD COMP 4.7 MEGOHM 10% 1/4W	01121	CB 4751
A28R42	0757-0433		R:FXD MET FLM 3.32K OHM 1% 1/8W	28480	0757-0433
A28R43	0757-0439	2	R:FXD MET FLM 6.81K OHM 1% 1/8W	28480	0757-0439
A28R44	0757-0457		R:FXD MET FLM 47.5K OHM 1% 1/8W	28480	0757-0457
A28R45	0684-1051	1	R:FXD COMP 1MEGOHM 1% 1/4W	01121	CB 1051
A28R46	0757-0280		R:FXD MET FLM 1K OHM 1% 1/8W	28480	0757-0280
A28R47	0757-0270	2	R:FXD MET FLM 249K OHM 1% 1/8W	28480	0757-0270
A28R48	0684-4751		R:FXD COMP 4.7 MEGOHM 10% 1/4W	01121	CB 4751
A28R49	0698-3499	1	R:FXD FLM 40.2K OHM 1% 1/8W	28480	0698-3499
A28R50	0598-3228		R:FXD MET FLM 49.9K OHM 1% 1/8W	28480	0698-3228
A28R51	0684-4751		R:FXD COMP 4.7 MEGOHM 10% 1/4W	01121	CB 4751
A28R52	0757-0270		R:FXD MET FLM 249K OHM 1% 1/8W	28480	0757-0270
A28TC1	0853-0017	1	THERMOCOUPLE	28480	0853-0017
A29A (A ONLY)	03330-66566	1	PC ASSY:MODULATOR BOARD	28480	03330-66566
	1205-0037	1	HEATSINK:SEMICON	28480	1205-0037
A29C1	0150-0093		C:FXD CER 0.01 UF +80-20% 100VDCW	72982	801-K800011
A29C2	0140-0201	2	C:FXD MICA 12 PF 5%	28480	0140-0201
A29C3	0150-0093		C:FXD CER 0.01 UF +80-20% 100VDCW	72982	801-K800011
A29C4	0150-0093		C:FXD CER 0.01 UF +80-20% 100VDCW	72982	801-K800011
A29C5	0160-2322	4	C:FXD MICA 18 PF 5% 100VDCW	00853	RDML5C180J15
A29C6	0140-0175	4	C:FXD MICA 39 PF 2% 300VDCW	28480	0140-0175
A29C7	0150-0093		C:FXD CER 0.01 UF +80-20% 100VDCW	72982	801-K800011
A29C8	0160-2322		C:FXD MICA 18 PF 5% 100VDCW	00853	RDML5C180J15
A29C9	0140-0175		C:FXD MICA 39 PF 2% 300VDCW	28480	0140-0175
A29C10	0150-0093		C:FXD CER 0.01 UF +80-20% 100VDCW	72982	801-K800011
A29C11*	0150-0022	4	C:FXD TI 3.3 PF 10% 500VDCW	78488	CA
A29C12	0150-0093		C:FXD CER 0.01 UF +80-20% 100VDCW	72982	801-K800011
A29C13	0150-0093		C:FXD CER 0.01 UF +80-20% 100VDCW	72982	801-K800011
A29C14	0140-0217	4	C:FXD MICA 140 PF 2%	28480	0140-0217
A29C15	0150-0093		C:FXD CER 0.01 UF +80-20% 100VDCW	72982	801-K800011
A29C16	0140-0217		C:FXD MICA 140 PF 2%	28480	0140-0217
A29C17	0160-2198	8	C:FXD MICA 20 PF 5%	72136	RDML5C200J3C
A29C18	0160-0363		C:FXD MICA 620PF 5%	28480	0160-0363
A29C19	0160-2150	2	C:FXD MICA 33 PF 5%	28480	0160-2150

See introduction to this section for ordering information

Table 6-1. Replaceable Parts(Cont'd)

Reference Designation	HP Part Number	Qty	Description	Mfr Code	Mfr Part Number
A29C20	0160-2198		C:FXD MICA 20 PF 5%	72136	RDM15C200J3C
A29C21			NOT ASSIGNED		
A29C22	0160-2206	1	C:FXD MICA 160 PF 5%	28480	0160-2206
A29C23	0140-0208		C:FXD MICA 690 PF 5%	72136	RDM15F681J3C
A29C24	0140-0196	3	C:FXD MICA 150 PF 5%	72136	RDM15F151J3C
A29C25	0160-0205		C:FXD MICA 10 PF 5%	28480	0160-0205
A29C26	0140-0196		C:FXD MICA 150 PF 5%	72136	RDM15F151J3C
A29C27	0150-0022		C:FXD TI 3.3 PF 10% 500VDCW	78488	GA
A29C28			NOT ASSIGNED		
A29C29	0140-0196		C:FXD MICA 150 PF 5%	72136	RDM15F151J3C
A29C30	0150-0022		C:FXD TI 3.3 PF 10% 500VDCW	78488	GA
A29C31	0150-0093		C:FXD CER 0.01 UF +80-20% 100VDCW	72982	801-K800011
A29C32	0180-1746		C:FXD ELECT 15 UF 10% 20VDCW	28480	0180-1746
A29C33	0150-0093		C:FXD CER 0.01 UF +80-20% 100VDCW	72982	801-K800011
A29C34	0180-1746		C:FXD ELECT 15 UF 10% 20VDCW	28480	0180-1746
A29Ck1	1902-0777		DIODE:BREAKDOWN 6.2V 5%	04713	1N825
A29C1	1821-0001	2	TRANSISTOR ARRAY:SI NPN	02735	CA3046
A29C2	1820-0223	3	INTEGRATED CIRCUIT:OPERATIONAL AMPL.	28480	1820-0223
A29C3	1820-0223		INTEGRATED CIRCUIT:OPERATIONAL AMPL.	28480	1820-0223
A29C4	1820-0223		INTEGRATED CIRCUIT:OPERATIONAL AMPL.	28480	1820-0223
A29L1	9140-0180	2	COIL/CHOKE 2.70 UH 10%	28480	9140-0180
A29L2	9100-3341	4	COIL/CHOKE 1.0 UH 2%	82142	4425-6C
A29L3	9100-3341		COIL/CHOKE 1.0 UH 2%	82142	4425-6C
A29L4	9100-1614		COIL/CHOKE=0.82 UH 10%	28480	9100-1614
A29L5	9140-0111	5	COIL/CHOKE 3.30 UH 10%	99800	1537-24
A29L6	9140-0120	2	COIL:FXD 0.10 UH 20%	82142	10175-8
A29L7	9140-0111		COIL/CHOKE 3.30 UH 10%	99800	1537-24
A29L8	9100-1669	1	COIL/CHOKE 5600 UH 5%	99800	2500-64
A29L9	9100-1671	1	COIL/CHOKE 4700 UH 5%	82142	24-1313-22J
A29L10	9140-0107		COIL:FXD RF 27 UH 10%	99800	1840-38
A29L11	9140-0107		COIL:FXD RF 27 UH 10%	99800	1840-38
A29Q1	1854-0345		TSTR:SI NPN	80131	2N5179
A29Q2	1854-0345		TSTR:SI NPN	80131	2N5179
A29Q3	1853-0066	4	TSTR:SI PNP	80131	2N4250
A29Q4	1853-0066		TSTR:SI PNP	80131	2N4250
A29Q5	1854-0345		TSTR:SI NPN	80131	2N5179
A29Q6	1854-0019		TSTR:SI NPN	28480	1854-0019
A29Q7	1854-0019		TSTR:SI NPN	28480	1854-0019
A29R1	0757-0280		R:FXD MET FLM 1K OHM 1% 1/8W	28480	0757-0280
A29R2	0757-0438	5	R:FXD MET FLM 5.11K OHM 1% 1/8W	28480	0757-0438
A29R3	0757-0277		R:FXD MET FLM 49.9 OHM 1% 1/8W	28480	0757-0277
A29R4	0757-0277		R:FXD MET FLM 49.9 OHM 1% 1/8W	28480	0757-0277
A29R5	0698-4476	2	R:FXD FLM 10.2K OHM 1% 1/8W	28480	0698-4476
A29R6	0698-4466	2	R:FXD MET FLM 976 OHM 1% 1/8W	28480	0698-4466
A29R7	0757-0381	2	R:FXD FLM 15 OHM 1% 1/8W	28480	0757-0381
A29R8	0698-4123		R:FXD MET FLM 499 OHM 1% 1/8W	28480	0698-4123
A29R9	0698-4123		R:FXD MET FLM 499 OHM 1% 1/8W	28480	0698-4123
A29R10	0698-4123		R:FXD MET FLM 499 OHM 1% 1/8W	28480	0698-4123
A29R11			NOT ASSIGNED		
A29R12	0698-4440	4	R:FXD FLM 3.4K OHM 1% 1/8W	28480	0698-4440
A29R13	0757-0277		R:FXD MET FLM 49.9 OHM 1% 1/8W	28480	0757-0277
A29R14	0698-3202	2	R:FXD MET FLM 1.74K OHM 1% 1/8W	28480	0698-3202
A29R15	0757-0277		R:FXD MET FLM 49.9 OHM 1% 1/8W	28480	0757-0277
A29R16	0698-4440		R:FXD FLM 3.4K OHM 1% 1/8W	28480	0698-4440
A29R17	0698-3447	1	R:FXD MET FLM 422 OHM 1% 1/8W	28480	0698-3447
A29R18	0757-0427		R:FXD MET FLM 1.5K OHM 1% 1/8W	28480	0757-0427
A29R19	0757-0427		R:FXD MET FLM 1.5K OHM 1% 1/8W	28480	0757-0427
A29R20	0757-0277		R:FXD MET FLM 49.9OHM 1% 1/8W	24546	C4-1/8-TO-4992-F
A29R21			NOT ASSIGNED		
A29R22	0757-0408	2	R:FXD MET FLM 243 OHM 1% 1/8W	28480	0757-0408
A29R23	0757-0398	3	R:FXD MET FLM 75 OHM 1% 1/8W	28480	0757-0398
A29R24	0757-0283		R:FXD MET FLM 2.00K OHM 1% 1/8W	28480	0757-0283
A29R25	2100-2633	3	R:VAR CERMET 1K OHM 10% LIN 1/2W	28480	2100-2633
A29R26	0757-0289		R:FXD MET FLM 13.3K OHM 1% 1/8W	28480	0757-0289
A29R27	0757-0476		R:FXD FLM 301 K OHM 1% 1/8W	28480	0757-0476
A29R28	0757-0444	2	R:FXD MET FLM 12.1K OHM 1% 1/8W	28480	0757-0444
A29R29	0698-3558		R:FXD MET FLM 4.02K OHM 1% 1/8W	28480	0698-3558
A29R30	0757-0453		R:FXD MET FLM 30.1K OHM 1% 1/8W	28480	0757-0453
A29R31	0757-0453		R:FXD MET FLM 30.1K OHM 1% 1/8W	28480	0757-0453
A29R32	0698-4453		R:FXD FLM 402 OHM 1% 1/8W	28480	0698-4453
A29R33	0698-4487	1	R:FXD FLM 25.5K OHM 1% 1/8W	28480	0698-4487
A29R34	0698-3497	5	R:FXD FLM 6.04K OHM 1% 1/8W	28480	0698-3497
A29R35	0698-3511		R:FXD FLM 665 OHM 1% 1/8W	28480	0698-3511
A29R36	0698-3449	1	R:FXD MET FLM 28.7K OHM 1% 1/8W	28480	0698-3449
A29R37	2100-2489		R:VAR FLM 5K OHM 10% LIN 1/2W	28480	2100-2489

See introduction to this section for ordering information

Table 6-1. Replaceable Parts(Cont'd)

Reference Designation	HP Part Number	Qty	Description	Mfr Code	Mfr Part Number
A29R38	0757-0288	2	R:FXD MET FLM 9.09K OHM 1% 1/8W	28480	0757-0288
A29B (B ONLY)	03330-66524	1	P.C. ASSY:AMPLITUDE/M BOARD	28480	03330-66524
A29 C1	0180-0374		C:FXD TANT. 10 UF 10% 20VDCW	56289	1500106X9020B2-DYS
A29 C2	0180-1735		C:FXD ELECT 0.22 UF 10% 35VDCW	28480	0180-1735
A29 C3	0180-1735		C:FXD ELECT 0.22 UF 10% 35VDCW	28480	0180-1735
A29 C4	0180-0374		C:FXD TANT. 10 UF 10% 20VDCW	56289	1500106X902032-DYS
A29 C5	0180-0373	1	C:FXD ELECT 0.68 UF 10% 35VDCW	56289	1500684X9035A2-DYS
A29 C6			NOT ASSIGNED		
A29 C7	0180-1743	2	C:FXD ELECT 0.1 UF 10% 35VDCW	56289	1500104X9035A2-DYS
A29 C8	0160-0154	4	C:FXD MICA MY 0.0022 UF 10% 200VDCW	56289	192P22292-PTS
A29 C9	0160-0154		C:FXD MICA MY 0.0022 UF 10% 200VDCW	56289	192P22292-PTS
A29 C10	0180-1743		C:FXD ELECT 0.1 UF 10% 35VDCW	56289	1500104X9035A2-DYS
A29 C11	0160-0159	1	C:FXD MY 0.0068 UF 10% 200VDCW	56289	192P68282-PTS
A29 C12	0150-0084		C:FXD CER 0.1 UF +80-20% 100VDCW	72982	8131-100-651-104Z
A29 C13	0150-0093		C:FXD CER 0.01 UF +80-20% 100VDCW	72982	801-K800011
A29 C14	0140-0201		C:FXD MICA 12 PF 5%	28480	0140-0201
A29 C15	0150-0093		C:FXD CER 0.01 UF +80-20% 100VDCW	72982	801-K800011
A29 C16	0150-0093		C:FXD CER 0.01 UF +80-20% 100VDCW	72982	801-K800011
A29 C17	0140-0175		C:FXD MICA 39 PF 2% 300VDCW	28480	0140-0175
A29 C18	0150-0093		C:FXD CER 0.01 UF +80-20% 100VDCW	72982	801-K800011
A29 C19	0140-0175		C:FXD MICA 39 PF 2% 300VDCW	28480	0140-0175
A29 C20	0150-0093		C:FXD CER 0.01 UF +80-20% 100VDCW	72982	801-K800011
A29 C21	0140-0217		C:FXD MICA 140 PF 2%	28480	0140-0217
A29 C22	0150-0093		C:FXD CER 0.01 UF +80-20% 100VDCW	72982	801-K800011
A29 C23	0140-0217		C:FXD MICA 140 PF 2%	28480	0140-0217
A29 C24	0160-2198		C:FXD MICA 20 PF 5%	72136	RDM15C200J3C
A29 C25	0160-0363		C:FXD MICA 620PF 5%	28480	0160-0363
A29 C26	0180-1746		C:FXD ELECT 15 UF 10% 20VDCW	28480	0180-1746
A29 C27	0180-1746		C:FXD ELECT 15 UF 10% 20VDCW	28480	0180-1746
A29 C28	0150-0093		C:FXD CER 0.01 UF +80-20% 100VDCW	72982	801-K800011
A29 C29	0160-0128	13	C:FXD CER 2.2 UF 20% 25VDCW	56289	5C152C2S-CML
A29 C30	0150-0093		C:FXD CER 0.01 UF +80-20% 100VDCW	72982	801-K800011
A29 C31	0160-2150		C:FXD MICA 33 PF 5%	28480	0160-2150
A29 C32	0160-2198		C:FXD MICA 20 PF 5%	72136	RDM15C200J3C
A29 C33	0150-0022		C:FXD TI 3.3 PF 10% 500VDCW	78488	GA
A29 C34	0160-2322		C:FXD MICA 18 PF 5% 100VDCW	00853	RDM15C180J1S
A29 C35	0160-2322		C:FXD MICA 18 PF 5% 100VDCW	00853	RDM15C190J1S
A29 C36	0150-0093		C:FXD CER 0.01 UF +80-20% 100VDCW	72982	801-K800011
A29 CR1	1901-0040		DIODE:SILICON 30MA 30WV	07263	FDG1088
A29 CR2	1901-0040		DIODE:SILICON 30MA 30WV	07263	FDG1088
A29 CR3	1901-0040		DIODE:SILICON 30MA 30WV	07263	FDG1088
A29 IC1	1826-0043		IC:LINEAR OPERATIONAL AMPLIFIER	28480	1826-0043
A29 IC2	1826-0043		IC:LINEAR OPERATIONAL AMPLIFIER	28480	1826-0043
A29 IC3	1826-0043		IC:LINEAR OPERATIONAL AMPLIFIER	28480	1826-0043
A29 IC4	1826-0043		IC:LINEAR OPERATIONAL AMPLIFIER	28480	1826-0043
A29 IC5	1821-0001		TRANSISTOR ARRAY:SI NPN	02735	CA3046
A29 IC6	1826-0043		IC:LINEAR OPERATIONAL AMPLIFIER	28480	1826-0043
A29 K1	0490-1015		RELAY:REED COIL 10 VA 250V	15636	R2731-2
A29 L1	9140-0180		COIL/CHOKER 2.70 UH 10%	28480	9140-0180
A29 L2	9100-3341		COIL/CHOKER 1.0 UH 2%	82142	4425-6C
A29 L3	9100-3341		COIL/CHOKER 1.0 UH 2%	82142	4425-6C
A29 L4	9100-1614		COIL/CHOKER:0.82 UH 10%	28480	9100-1614
A29 L5	9140-0111		COIL/CHOKER 3.30 UH 10%	99800	1537-24
A29 L6	9140-0120		COIL:FXD 0.10 UH 20%	82142	10175-8
A29 L7	9140-0107		COIL:FXD RF 27 UH 10%	99800	1840-38
A29 L8	9140-0107		COIL:FXD RF 27 UH 10%	99800	1840-38
A29 L9			NOT ASSIGNED		
A29 L10	9140-0111		COIL/CHOKER 3.30 UH 10%	99800	1537-24
A29 Q1	1854-0071		TSTR:SI NPN(SELECTED FROM 2N3704)	28480	1854-0071
A29 Q2	1853-0020		TSTR:SI PNP(SELECTED FROM 2N3702)	28480	1853-0020
A29 Q3	1854-0071		TSTR:SI NPN(SELECTED FROM 2N3704)	28480	1854-0071
A29 Q4	1855-0081		TSTR:SI FET	80131	2N5245
A29 Q5	1855-0081		TSTR:SI FET	80131	2N5245
A29 Q6	1853-0066		TSTR:SI PNP	80131	2N4250
A29 Q7	1853-0066		TSTR:SI PNP	80131	2N4250
A29 Q8	1854-0345		TSTR:SI NPN	80131	2N5179
A29 Q9	1854-0019		TSTR:SI NPN	28480	1854-0019
A29 Q10	1854-0019		TSTR:SI NPN	28480	1854-0019
A29 Q11	1854-0210		TSTR:SI NPN	80131	2N2222
A29 Q12	1854-0345		TSTR:SI NPN	80131	2N5179
A29 Q13	1854-0345		TSTR:SI NPN	80131	2N5179
A29 R1	0698-3518	4	R:FXD FLM 7.32K OHM 1% 1/8W	28480	0698-3518
A29 R2	0698-3518		R:FXD FLM 7.32K OHM 1% 1/8W	28480	0698-3518
A29 R3	0757-0280		R:FXD MET FLM 1K OHM 1% 1/8W	28480	0757-0280
A29 R4	0757-0463		R:FXD MET FLM 82.5K OHM 1% 1/8W	28480	0757-0463

See introduction to this section for ordering information

Table 6-1. Replaceable Parts(Cont'd)

Reference Designation	HP Part Number	Qty	Description	Mfr Code	Mfr Part Number
A29 R5	0757-0444	8	R:FXD MET FLM 12.1K OHM 1% 1/8W	28480	0757-0444
A29 R6	0698-4307		R:FXD FLM 14.3K OHM 1% 1/8W	28480	0698-4307
A29 R7	0698-4482		R:FXD FLM 17.4K OHM 1% 1/8W	28480	0698-4482
A29 R8	0698-3259		R:FXD FLM 7.87K OHM 1% 1/8W	28480	0698-3259
A29 R9	0757-0437	3	R:FXD MET FLM 4750 OHM 1% 1/8W	28480	0757-0437
A29 R10	0757-0452		R:FXD MET FLM 27.4K OHM 1% 1/8W	28480	0757-0452
A29 R11	0757-0452		R:FXD MET FLM 27.4K OHM 1% 1/8W	28480	0757-0452
A29 R12	0757-0452		R:FXD MET FLM 27.4K OHM 1% 1/8W	28480	0757-0452
A29 R13	0684-4751		R:FXD COMP 4.7 MEGOHM 10% 1/4W	01121	CB 4751
A29 R14	0757-0452		R:FXD MET FLM 27.4K OHM 1% 1/8W	28480	0757-0452
A29 R15	0757-0452		R:FXD MET FLM 27.4K OHM 1% 1/8W	28480	0757-0452
A29 R16	0684-4751		R:FXD COMP 4.7 MEGOHM 10% 1/4W	01121	CB 4751
A29 R17	0698-3518		R:FXD FLM 7.32K OHM 1% 1/8W	28480	0698-3518
A29 R18	0698-3518		R:FXD FLM 7.32K OHM 1% 1/8W	28480	0698-3518
A29 R19	0757-0280		R:FXD MET FLM 1K OHM 1% 1/8W	28480	0757-0280
A29 R20	0757-0463		R:FXD MET FLM 82.5K OHM 1% 1/8W	28480	0757-0463
A29 R21	0757-0444		R:FXD MET FLM 12.1K OHM 1% 1/8W	28480	0757-0444
A29 R22	0698-4307		R:FXD FLM 14.3K OHM 1% 1/8W	28480	0698-4307
A29 R23	0698-4482		R:FXD FLM 17.4K OHM 1% 1/8W	28480	0698-4482
A29 R24	0698-3259		R:FXD FLM 7.87K OHM 1% 1/8W	28480	0698-3259
A29 R25	0757-0288		R:FXD MET FLM 9.09K OHM 1% 1/8W	28480	0757-0288
A29 R26	0757-0280		R:FXD MET FLM 1K OHM 1% 1/8W	28480	0757-0280
A29 R27	0757-0438		R:FXD MET FLM 5.11K OHM 1% 1/8W	28480	0757-0438
A29 R28	0757-0381		R:FXD FLM 15 OHM 1% 1/8W	28480	0757-0381
A29 R29	0698-4476		R:FXD FLM 10.2K OHM 1% 1/8W	28480	0698-4476
A29 R30	0698-4123		R:FXD MET FLM 499 OHM 1% 1/8W	28480	0698-4123
A29 R31	0698-4123		R:FXD MET FLM 499 OHM 1% 1/8W	28480	0698-4123
A29 R32	0698-4123		R:FXD MET FLM 499 OHM 1% 1/8W	28480	0698-4123
A29 R33	2100-2633		R:VAR CERMET 1K OHM 10% LIN 1/2W	28480	2100-2633
A29 R34	0698-3223		R:FXD FLM 1.24K OHM 1% 1/8W	28480	0698-3223
A29 R35	0698-4440		R:FXD FLM 3.4K OHM 1% 1/8W	28480	0698-4440
A29 R36	0698-3202		R:FXD MET FLM 1.74K OHM 1% 1/8W	28480	0698-3202
A29 R37	0698-4440		R:FXD FLM 3.4K OHM 1% 1/8W	28480	0698-4440
A29 R38	0757-0277		R:FXD MET FLM 49.9 OHM 1% 1/8W	28480	0757-0277
A29 R39	0757-0277		R:FXD MET FLM 49.9 OHM 1% 1/8W	28480	0757-0277
A29 R40	0698-3488		1	R:FXD MET FLM 442 OHM 1% 1/8W	28480
A29 R41	0757-0427	R:FXD MET FLM 1.5K OHM 1% 1/8W		28480	0757-0427
A29 R42	0757-0277	R:FXD MET FLM 49.9 OHM 1% 1/8W		24546	C4-1/8-T0-4992-F
A29 R43	0757-0427	R:FXD MET FLM 1.5K OHM 1% 1/8W		28480	0757-0427
A29 R44	0757-0408		R:FXD MET FLM 243 OHM 1% 1/8W	28480	0757-0408
A29 R45	0757-0398		R:FXD MET FLM 75 OHM 1% 1/8W	28480	0757-0398
A29 R46	0757-0283		R:FXD MET FLM 2.00K OHM 1% 1/8W	28480	0757-0283
A29 R47	0698-3700		R:FXD FLM 715 OHM 1% 1/8W	28480	0698-3700
A29 R48	0757-0434	1	R:FXD MET FLM 3.65K OHM 1% 1/8W	28480	0757-0434
A29 R49	0757-0398		R:FXD MET FLM 75 OHM 1% 1/8W	28480	0757-0398
A29 R50	0757-0273		R:FXD MET FLM 3.01K OHM 1% 1/8W	28480	0757-0273
A29 R51	0757-0277		R:FXD MET FLM 49.9 OHM 1% 1/8W	28480	0757-0277
A29 R52	0757-0277		R:FXD MET FLM 49.9 OHM 1% 1/8W	28480	0757-0277
A29 R53	0698-4466		R:FXD MET FLM 976 OHM 1% 1/8W	28480	0698-4466
A29 SW1	3101-1341		SWITCH:SLIDE SPDT 0.5A 125V AC/DC	79727	C-111-0004
A30	03330-66525		1	PC ASSY:OUTPUT MIXER BOARD	28480
A30C1	0180-0374	C:FXD TANT. 10 UF 10% 20VDCW		56289	150D106X902082-DYS
A30C2	0180-0374	C:FXD TANT. 10 UF 10% 20VDCW		56289	150D106X902082-DYS
A30C3		NOT ASSIGNED			
A30C4	0180-0291	2	C:FXD ELECT 1.0 UF 10% 35VDCW	56289	150D105X9035A2-DYS
A30C5	0150-0121		C:FXD CER 0.1 UF +80-20% 50VDCW	56289	5C503IS-CML
A30C6	0150-0093		C:FXD CER 0.01 UF +80-20% 100VDCW	72982	801-K800011
A30C7	0150-0093		C:FXD CER 0.01 UF +80-20% 100VDCW	72982	801-K800011
A30C8	0150-0093	1	C:FXD CER 0.01 UF +80-20% 100VDCW	72982	801-K800011
A30C9	0140-0195		C:FXD MICA 130 PF 5% 300VDCW	14655	DM15F131J-300V
A30C10	0160-0373		C:FXD MICA 27PF 5%	72136	RDML5E270J5S
A30C11	0150-0093		C:FXD CER 0.01 UF +80-20% 100VDCW	72982	801-K800011
A30C12	0140-0197		C:FXD MICA 180 PF 5% 300VDCW	14655	RDML5F181J3C
A30C13	0150-0093		C:FXD CER 0.01 UF +80-20% 100VDCW	72982	801-K800011
A30C14	0150-0093		C:FXD CER 0.01 UF +80-20% 100VDCW	72982	801-K800011
A30C15	0160-2198		C:FXD MICA 20 PF 5%	72136	RDML5C200J3C
A30C16	0160-2135	1	C:FXD PDRG 4.3 PF 500VDCW	95275	VY04C4R38
A30C17	0160-2256		C:FXD CER 9.1 PF 500VDCW	72982	301-000-C0K0-919C
A30C18	0121-0105		C:VAR CER 9-35 PF NPD	28480	0121-0105
A30C19	0121-0059		C:VAR CER 2-8 PF 300VDCW	28480	0121-0059
A30C20	0180-0291		C:FXD ELECT 1.0 UF 10% 35VDCW	56289	150D105X9035A2-DYS
A30C21	0140-0198		C:FXD MICA 200 PF 5%	72136	RDML5F201J3C
A30C22	0180-0374		C:FXD TANT. 10 UF 10% 20VDCW	56289	150D106X902082-DYS
A30C23			NOT ASSIGNED		
A30C24	0180-0291		C:FXD ELECT 1.0 UF 10% 35VDCW	56289	150D105X9035A2-DYS

See introduction to this section for ordering information

Table 6-1. Replaceable Parts(Cont'd)

Reference Designation	HP Part Number	Qty	Description	Mfr Code	Mfr Part Number
A30C25	0180-0291	1	C:FXD ELECT 1.0 UF 10% 35VDCW	56289	1500105X9035A2-DYS
A30C26	0160-2204		C:FXD MICA 100PF 5%	72136	RDM15F101J3C
A30C27	0160-0157		C:FXD MY 0.0047 UF 10% 200VDCW	56289	192P47252-PTS
A30C28	0140-0198		C:FXD MICA 200 PF 5%	72136	RDM15F201J3C
A30C29	0160-0174		C:FXD CER 0.47 UF +80-20% 25VDCW	56289	5C11875-CML
A30C30	0180-0291	1	C:FXD ELECT 1.0 UF 10% 35VDCW	56289	1500105X9035A2-DYS
A30C31	0180-1746		C:FXD ELECT 15 UF 10% 20VDCW	28480	0180-1746
A30C32	0180-1746		C:FXD ELECT 15 UF 10% 20VDCW	28480	0180-1746
A30C33	0180-1746		C:FXD ELECT 15 UF 10% 20VDCW	28480	0180-1746
A30C34	0150-0093		C:FXD CER 0.01 UF +80-20% 100VDCW	72982	801-K800011
A30C35	0150-0093	1	C:FXD CER 0.01 UF +80-20% 100VDCW	72982	801-K800011
A30C36	0150-0093		C:FXD CER 0.01 UF +80-20% 100VDCW	72982	801-K800011
A30C37	0180-0309		C:FXD ELECT 4.7 UF 20% 10VDCW	56289	1500475X0010A2-DYS
A30C38	0150-0029		C:FXD TI 1 PF 10% 500VDCW	78488	TYPE GA
A30C39	0150-0121		C:FXD CER 0.1 UF +80-20% 50VDCW	56289	5C5081S-CML
A30C40, C41	0150-0084	1	C:FXD .1UF +80-20%	28480	0150-0084
A30CR1	1901-0044		DIODE:SILICON 20MA/1V	28480	1901-0044
A30CR2			UNASSIGNED		
A30CR3	1901-0044		DIODE:SILICON 20MA/1V	28480	1901-0044
A30IC1	1826-0043		IC:LINEAR OPERATIONAL AMPLIFIER	28480	1826-0043
A30IC2	1826-0043	1	IC:LINEAR OPERATIONAL AMPLIFIER	28480	1826-0043
A30IC3	1826-0043		IC:LINEAR OPERATIONAL AMPLIFIER	28480	1826-0043
A30IC4	1826-0062		IC	28480	1826-0062
A30IC5	1858-0015		IC	28480	1858-0015
A30P1	1250-1195		CONNECTOR:RF SUB-MINIATURE SERIES	98291	52-053-0000
A30L1	9100-1611	2	COIL:FXD 0.22 UH 20%	28480	9100-1611
A30L2	9100-1616		COIL/CHOKO 1.50 UH 10%	99800	1537-16
A30L3	9100-1611		COIL:FXD 0.22 UH 20%	28480	9100-1611
A30L4	9100-3316		COIL:FXD 5.6 UH	28480	9100-3316
A30L5	9100-3311		COIL:FXD 6.0 UH	28480	9100-3311
A30L6	9140-0107	1	COIL:FXD RF 27 UH 10%	99800	1840-38
A30L7	9140-0107		COIL:FXD RF 27 UH 10%	99800	1840-38
A30L8			NOT ASSIGNED		
A30L9	9140-0111		COIL/CHOKO 3.30 UH 10%	99800	1537-24
A30Q1	1854-0404		TSTR:SI NPN	28480	1854-0404
A30Q2	1854-0457	1	TSTR:SI NPN	28480	1854-0457
A30Q3	1853-0036		TSTR:SI PNP	28480	1853-0036
A30Q4	1854-0215		TSTR:SI NPN	04713	SPS 3611
A30Q5	1854-0215		TSTR:SI NPN	04713	SPS 3611
A30Q6	1853-0036		TSTR:SI PNP	28480	1853-0036
A30Q7	1853-0010	TSTR:SI PNP(SELECTED FROM 2N3251)	28480	1853-0010	
A30Q8	1853-0010	5	TSTR:SI PNP(SELECTED FROM 2N3251)	28480	1853-0010
A30R1	0757-0442		R:FXD MET FLM 10.0K OHM 1% 1/8W	28480	0757-0442
A30R2	0698-3279		R:FXD MET FLM 4990 OHM 1% 1/8W	28480	0698-3279
A30R3	0584-3911		R:FXD COMP 39J OHM 10% 1/4W	01121	CB 3911
A30R4	1810-0078		RESISTIVE NETWORK	28480	1810-0078
A30R5	0757-0438	1	R:FXD MET FLM 5.11K OHM 1% 1/8W	28480	0757-0438
A30R6	0757-0449		R:FXD FLM 20K OHM 1% 1/8W	28480	0757-0449
A30R7	2100-2633		R:VAR CERMET 1K OHM 10% LIN 1/2W	28480	2100-2633
A30R8	0757-0449		R:FXD FLM 20K OHM 1% 1/8W	28480	0757-0449
A30R9	0757-0277		R:FXD MET FLM 49.9 OHM 1% 1/8W	28480	0757-0277
A30R10	0757-0277	2	R:FXD MET FLM 49.9 OHM 1% 1/8W	28480	0757-0277
A30R11	0757-0289		R:FXD MET FLM 13.3K OHM 1% 1/8W	28480	0757-0289
A30R12	0757-0281		R:FXD MET FLM 2.74K OHM 1% 1/8W	28480	0757-0281
A30R13	0757-0281		R:FXD MET FLM 2.74K OHM 1% 1/8W	28480	0757-0281
A30R14	0757-0289		R:FXD MET FLM 13.3K OHM 1% 1/8W	28480	0757-0289
A30R15	0757-0401	1	R:FXD MET FLM 100 OHM 1% 1/8W	28480	0757-0401
A30R16	0698-4422		R:FXD FLM 1.27K OHM 1% 1/8W	28480	0698-4422
A30R17	0757-0401		R:FXD MET FLM 100 OHM 1% 1/8W	28480	0757-0401
A30R18	2100-2574		R:VAR CERMET 500 OHM 10% LIN 1/2W	28480	2100-2574
A30R19	0698-4426		R:FXD FLM 1580 OHM 1% 1/8W	28480	0698-4426
A30R20	0757-0434	1	R:FXD MET FLM 3.65K OHM 1% 1/8W	28480	0757-0434
A30R21	0698-3223		R:FXD FLM 1.24K OHM 1% 1/8W	28480	0698-3223
A30R22	0757-0401		R:FXD MET FLM 100 OHM 1% 1/8W	28480	0757-0401
A30R23	0757-0401		R:FXD MET FLM 100 OHM 1% 1/8W	28480	0757-0401
A30R24	0698-4123		R:FXD MET FLM 499 OHM 1% 1/8W	28480	0698-4123
A30R25	0757-0439	1	R:FXD MET FLM 6.81K OHM 1% 1/8W	28480	0757-0439
A30R26	0757-0441		R:FXD MET FLM 8.25K OHM 1% 1/8W	28480	0757-0441
A30R27	0757-0389		R:FXD MET FLM 33.2 OHM 1% 1/8W	28480	0757-0389
A30R28	0757-0401		R:FXD MET FLM 100 OHM 1% 1/8W	28480	0757-0401
A30R29	0698-4435		R:FXD FLM 2.49K OHM 1% 1/8W	28480	0698-4435
A30R30	0757-0401	1	R:FXD MET FLM 100 OHM 1% 1/8W	28480	0757-0401
A30R31	0698-4433		R:FXD FLM 2260 OHM 1% 1/8W	28480	0698-4433
A30R32	0698-3151		R:FXD MET FLM 2.87K OHM 1% 1/8W	28480	0698-3151
A30R33	0698-3151		R:FXD MET FLM 2.87K OHM 1% 1/8W	28480	0698-3151
A30R34	0757-0401		R:FXD MET FLM 100 OHM 1% 1/8W	28480	0757-0401

See introduction to this section for ordering information

Table 6-1. Replaceable Parts(Cont'd)

Reference Designation	HP Part Number	Qty	Description	Mfr Code	Mfr Part Number
A30R35	2100-3154		R:VAR CERMET 1000 OHM 10% TYPE P 3/4W	28480	2100-3154
A30R36	0698-4123		R:FXD MET FLM 499 OHM 1% 1/8W	28480	0698-4123
A30R37	0757-0402	1	R:FXD MET FLM 110 OHM 1% 1/8W	28480	0757-0402
A30R38	0698-4123		R:FXD MET FLM 499 OHM 1% 1/8W	28480	0698-4123
A30R39	0757-0401		R:FXD MET FLM 100 OHM 1% 1/8W	28480	0757-0401
A30R40	2100-3054		R:VAR CERMET 50K OHM 10% 3/4W	28480	2100-3054
A30R41	0698-4211	1	R:FXD FLM 158K OHM 1% 1/8W	28480	0698-4211
A30R42	0698-4508	1	R:FXD FLM 78.7K OHM 1% 1/8W	28480	0698-4508
A30R43	0757-0278	1	R:FXD MET FLM 1.78K OHM 1% 1/8W	29480	0757-0278
A30R44	0698-3268	1	R:FXD FLM 11.5K OHM 1% 1/8W	28480	0698-3268
A30R45	0698-4457		R:FXD FLM 576 OHM 1% 1/8W	28480	0698-4457
A30R46	0757-0277	2	R:FXD MET FLM 49.9 OHM 1% 1/8W	28480	0757-0277
A30R47	0757-0438		R:FXD MET FLM 5.11K OHM 1% 1/8W	28480	0757-0438
A30R48	0757-0280		R:FXD MET FLM 1K OHM 1% 1/8W	28480	0757-0280
A30R49	0698-3151		R:FXD MET FLM 2.87K OHM 1% 1/8W	28480	0698-3151
A30R50	0757-0277		R:FXD MET FLM 49.9 OHM 1% 1/8W	28480	0757-0277
A30R51	2100-2413	1	R:VAR FLM 200 OHM 10% LIN 1/2W	28480	2100-2413
A30R52	0698-3151		R:FXD MET FLM 2.87K OHM 1% 1/8W	28480	0698-3151
A30R53	0698-4451	4	R:FXD FLM 340 OHM 1% 1/8W	28480	0698-4451
A30R54	0757-0438		R:FXD MET FLM 5.11K OHM 1% 1/8W	28480	0757-0438
A30R55	0757-0442		R:FXD MET FLM 10.0K OHM 1% 1/8W	28480	0757-0442
A30R56	0757-0442		R:FXD MET FLM 10.0K OHM 1% 1/8W	28480	0757-0442
A30R57	0684-5641	1	R:FXD COMP 560K OHM 10% 1/4W	01121	CB 5641
A30R58	0757-0437		R:FXD MET FLM 4750 OHM 1% 1/8W	28480	0757-0437
A30R59	0757-0277		R:FXD MET FLM 49.9 OHM 1% 1/8W	28480	0757-0277
A30R60	0757-0277		R:FXD MET FLM 49.9 OHM 1% 1/8W	28480	0757-0277
A30R61	0698-4123		R:FXD MET FLM 499 OHM 1% 1/8W	28480	0698-4123
A30R62	0698-3262		R:FXD MET FLM 40.2 OHM 1% 1/8W	28480	0698-3262
A30R63	0698-3558		R:FXD MET FLM 4.02K OHM 1% 1/8W	28480	0698-3558
A30R64	0757-0277		R:FXD MET FLM 49.9 OHM 1% 1/8W	28480	0757-0277
A30R65	0698-3262		R:FXD MET FLM 40.2 OHM 1% 1/8W	28480	0698-3262
A30R66	0757-0277		R:FXD MET FLM 49.9 OHM 1% 1/8W	28480	0757-0277
A30R67	0698-4452	7	R:FXD FLM 374 OHM 1% 1/8W	28480	0698-4452
A30R68	0698-4123		R:FXD MET FLM 499 OHM 1% 1/8W	28480	0698-4123
A30R69	0757-0453		R:FXD MET FLM 30.1K OHM 1% 1/8W	28480	0757-0453
A30R100* Δ8	0757-0405	1	R:FXD 162 OHM 1%	24546	C4-1/8-T0-162R-F
A30SW1	3101-1341		SWITCH:SLIDE SPDT 0.5A 125V AC/DC	79727	C-111-0004
A30T1	9100-1393		TRANSFORMER:T0R01D	28480	9100-1393
A31(B ONLY)	03330-66526	1	PC ASSY:ATTENUATOR BOARD	28480	03330-66526
A31(B ONLY)	03330-66570	1	(OPTION 001)	28480	03330-66570
A31C1	0150-0093		C:FXD CER 0.01 UF +80-20% 100VDCW	72982	3J1-K800011
A31C2	0150-0093		C:FXD CER 0.01 UF +80-20% 100VDCW	72982	80L-K300011
A31C3	0150-0093		C:FXD CER 0.01 UF +80-20% 100VDCW	72982	80L-K800011
A31C4	0150-0093		C:FXD CER 0.01 UF +80-20% 100VDCW	72982	80L-K800011
A31C5	0180-1746		C:FXD ELECT 15 UF 10% 20VDCW	28480	0180-1746
A31CR1	1901-0040		DIODE:SILICON 30MA 30WV	07263	FDG1088
A31CR2	1901-0040		DIODE:SILICON 30MA 30WV	07263	FDG1088
A31CR3	1901-0040		DIODE:SILICON 30MA 30WV	07263	FDG1088
A31CR4	1901-0040		DIODE:SILICON 30MA 30WV	07263	FDG1088
A31IC1	1820-0583		IC:TTL LP QUAD 2-INPT NAND GATE	12040	DM74L00N
A31IC2	1820-0782		IC:TTL TRIPLE 3-INPT NOR GATE	01295	SN7427N
A31IC3	1820-0511		IC:TTL QUAD 2-INPT AND GATE	01295	SN7408N
A31J1	1250-1357	1	CONNECTOR:CDAX SUBMINIATURE, JACK	98291	52-052-0000
A31K1	0490-0963		RELAY:MULTI-REED	28480	0490-0963
A31K2	0490-0963		RELAY:MULTI-REED	28480	0490-0963
A31K3	0490-0963		RELAY:MULTI-REED	28480	0490-0963
A31K4	0490-0963		RELAY:MULTI-REED	28480	0490-0963
A31K5	0490-0963		RELAY:MULTI-REED	28480	0490-0963
A31L1	9100-1618		COIL:MOLDED CHOKE 5.60 UH	28480	9100-1618
A31P1	1250-1195		CONNECTOR:RF SUB-MINIATURE SERIES	98291	52-053-0000
A31D1	1854-0394		TSTR:SI NPN	28480	1854-0394
A31Q2	1854-0354		TSTR:SI NPN	28480	1854-0354
A31Q3	1854-0354		TSTR:SI NPN	28480	1854-0354
A31Q4	1854-0354		TSTR:SI NPN	28480	1854-0354
A31R1	0684-3911		R:FXD COMP 390 OHM 10% 1/4W	01121	CB 3911
A31R2	0684-3911		R:FXD COMP 390 OHM 10% 1/4W	01121	CB 3911
A31R3	0684-3911		R:FXD COMP 390 OHM 10% 1/4W	01121	CB 3911
A31R4	0684-3911		R:FXD COMP 390 OHM 10% 1/4W	01121	CB 3911
A31R5	0698-7984	8	R:FXD FLM 61.1 OHM .01% 1/2W	28480	0698-7984
A31R6	0698-8258	4	R:FXD FLM 247.5 OHM 1% 1/4W	30983	MF52C1/4-T9-247R5-8
A31R7	0698-7984		R:FXD FLM 61.1 OHM .01% 1/2W	28480	0698-7984
A31R8	0698-8390	2	R:FXD FLM 96.25 OHM 0.1% 1/4W	30983	MF7C1/2-T2-96R25-8
A31R9	0698-7982	1	R:FXD FLM 71.16 OHM 0.1% 1/4W	28480	0698-7982
A31R10	0698-8390		R:FXD FLM 96.25 OHM 0.1% 1/4W	30983	MF7C1/2-T2-96R25-8
A31R11	0698-7984		R:FXD FLM 61.1 OHM .01% 1/2W	28480	0698-7984
A31R12	0698-8258		R:FXD FLM 247.5 OHM 1% 1/4W	30983	MF52C-1/4-T9-247R5-8

See introduction to this section for ordering information

Table 6-1. Replaceable Parts(Cont'd)

Reference Designation	HP Part Number	Qty	Description	Mfr Code	Mfr Part Number
A31R13	0698-7984		R:FXD FLM 61.1 OHM .01% 1/2W	28480	0698-7984
A31R14	0698-7984		R:FXD FLM 61.1 OHM .01% 1/2W	28480	0698-7984
A31R15	0698-8258		R:FXD FLM247.5 OHM 1% 1/4W	30983	MF52C-1/4-T9-247R5-8
A31R16	0698-7984		R:FXD FLM 61.1 OHM .01% 1/2W	28480	0698-7984
A31R17	0698-7984		R:FXD FLM 61.1 OHM .01% 1/2W	28480	0698-7984
A31R18	0698-8258		R:FXD FLM247.5 OHM 1% 1/4W	30983	MF52C-1/4-T9-247R5-8
A31R19	0698-7984		R:FXD FLM 61.1 OHM .01% 1/2W	28480	0698-7984
A31R20	0698-8011	1	R:FXD FLM 25 OHM 0.1% 1/4W	28480	0698-8011
A32A (A ONLY)	03330-66571	1	PC ASSY:OUTPUT AMPLIFIER BOARD (OPTION 001)	28240	03330-66571
A32 C1	0160-2198		C:FXD MICA 20 PF 5%	72136	RDM15C200J3C
A32 C2	0160-0990	6	C:FXD MICA 100 PF 2% 300VDCW	00853	RDM15F101G3S
A32 C3	0160-2203		C:FXD MICA 91 PF 5%	72136	RDM15F910J3C
A32 C4	0160-0194	3	C:FXD MY 0.015 UF 10%	56289	192P15392-PTS
A32 C5	0140-0218	3	C:FXD MICA 160 PF 2%	28480	0140-0218
A32 C6	0160-0958	3	C:FXD MICA 390 PF 5% 300VDCW	00853	RDM15F391J3S
A32 C7	0160-2209	3	C:FXD MICA 360 PF 5%	72136	RDM15F361J3C
A32 C8	0140-0206	3	C:FXD MICA 270 PF 5%	72136	RDM15F2715 500V
A32 C9	0160-0128		C:FXD CER 2.2 UF 20% 25VDCW	56289	5C152C25-CML
A32 C10	0160-0128		C:FXD CER 2.2 UF 20% 25VDCW	56289	5C152C25-CML
A32 C11	0150-0093		C:FXD CER 0.01 UF +80-20% 100VDCW	72982	801-K800011
A32 C12	0150-0093		C:FXD CER 0.01 UF +80-20% 100VDCW	72982	801-K800011
A32 C13	0170-0079		C:FXD MY 0.047UF 20% 50VDCW	84411	STYLE 3 TYPE 601PE
A32 C14	0160-0990		C:FXD MICA 100 PF 2% 300VDCW	00853	RDM15F101G3S
A32 C15	0160-0127	3	C:FXD CER 1.0 UF 20% 25VDCW	56289	5C13CS-CML
A32 C16	0160-2605	3	C:FXD CER 0.02 MFD +80-20% 25VDCW	72982	5835000-Y5U 203Z
A32 C17	0150-0084		C:FXD CER 0.1 UF +80-20% 100VDCW	72982	8131-100-651-104Z
A32 C18	0150-0084		C:FXD CER 0.1 UF +80-20% 100VDCW	72982	8131-100-651-104Z
A32 C19	0150-0084		C:FXD CER 0.1 UF +80-20% 100VDCW	72982	8131-100-651-104Z
A32 C21	0180-0104	6	C:FXD ELECT 200 UF +75-10% 15VDCW	56289	30D2076015DF4-DSM
A32 C22	0160-0128		C:FXD CER 2.2 UF 20% 25VDCW	56289	5C152C25-CML
A32 C23	0160-0128		C:FXD CER 2.2 UF 20% 25VDCW	56289	5C152C25-CML
A32 C25	0150-0084		C:FXD CER 0.1 UF +80-20% 100VDCW	72982	8131-100-651-104Z
A32 C27	0180-0104		C:FXD ELECT 200 UF +75-10% 15VDCW	56289	30D2076015DF4-DSM
A32 C28	0180-1746		C:FXD ELECT 15 UF 10% 20VDCW	28480	0180-1746
A32 C29	0180-1746		C:FXD ELECT 15 UF 10% 20VDCW	28480	0180-1746
A32 CR1	1901-0040		DIODE:SILICON 30MA 30WV	07263	FDG1088
A32 CR2	1901-0040		DIODE:SILICON 30MA 30WV	07263	FDG1088
A32 CR3	1901-0040		DIODE:SILICON 30MA 30WV	07263	FDG1088
A32 CR4	1901-0040		DIODE:SILICON 30MA 30WV	07263	FDG1088
A32 CR5	1901-0040		DIODE:SILICON 30MA 30WV	07263	FDG1088
A32 CR6	1901-0040		DIODE:SILICON 30MA 30WV	07263	FDG1088
A32 CR7	1901-0040		DIODE:SILICON 30MA 30WV	07263	FDG1088
A32 CR8	1902-0025		DIODE,BREAKDOWN:10.0V 5% 400 MW	28480	1902-0025
A32 CR9	1901-0040		DIODE:SILICON 30MA 30WV	07263	FDG1088
A32 CR10	1902-0025		DIODE,BREAKDOWN:10.0V 5% 400 MW	28480	1902-0025
A32 IC1	1826-0043		IC:LINEAR OPERATIONAL AMPLIFIER	28480	1826-0043
A32 L1	9100-3319		COIL: MLD CHOKE 0.74 UH 2%	82142	08D
A32 L2	9100-3318	6	COIL:FXD 0.58 UH	28480	9100-3318
A32 L3	9100-3318		COIL:FXD 0.58 UH	28480	9100-3318
A32 L4	9100-1627		COIL/CHOKE 39 UH 5%	82142	15-1315-2J
A32 L5	9140-0107		COIL:FXD RF 27 UH 10%	99800	1840-38
A32 L6	9140-0107		COIL:FXD RF 27 UH 10%	99800	1840-38
A32 P1	1250-1339	3	CONNECTOR:COAX RF SUSMINIATURE	98291	52-051-0000
A32 Q1	1854-0345		TSTR:SI NPN	80131	2N5179
A32 Q2	1854-0345		TSTR:SI NPN	80131	2N5179
A32 Q3	1853-0203		TSTR:SI PNP	28480	1853-0203
A32 Q4	1854-0019		TSTR:SI NPN	28480	1854-0019
A32 Q5	1854-0053	3	TSTR:SI NPN	80131	2N2218
A32 Q6	1854-0345		TSTR:SI NPN	80131	2N5179
A32 Q7	1853-0203		TSTR:SI PNP	28480	1853-0203
A32 Q8	1853-0012	3	TSTR:SI PNP	80131	2N2904A
A32 R1	0698-8177	6	R:FXD FLM 1.5 OHM 5% 1/4W	28480	0698-8177
A32 R2	0698-4464	3	R:FXD FLM 887 OHM 1% 1/8W	28480	0698-4464
A32 R3	0698-8177		R:FXD FLM 1.5 OHM 5% 1/4W	28480	0698-8177
A32 R4	0698-4354	3	R:FXD FLM 11.8 OHM 1% 1/8W	28480	0698-4354
A32 R5	0698-3441	3	R:FXD MET FLM 215 OHM 1% 1/8W	28480	0698-3441
A32 R6	0757-0395	3	R:FXD MET FLM 56.2 OHM 1% 1/8W	28480	0757-0395
A32 R7	0698-3443	3	R:FXD MET FLM 287 OHM 1% 1/8W	28480	0698-3443
A32 R8	0757-0280		R:FXD MET FLM 1K OHM 1% 1/8W	28480	0757-0280
A32 R9	0757-0393	24	R:FXD FLM 47.5 OHM 1% 1/8W	28480	0757-0393
A32 R10	0757-0739	6	R:FXD MET FLM 2.00K OHM 1% 1/4W	28480	0757-0739
A32 R11	0757-0393		R:FXD FLM 47.5 OHM 1% 1/8W	28480	0757-0393
A32 R12	0757-0739		R:FXD MET FLM 2.00K OHM 1% 1/4W	28480	0757-0739
A32 R13	0757-0378	3	R:FXD MET FLM 11.0 OHM 1% 1/8W	28480	0757-0378
A32 R14	0757-0280		R:FXD MET FLM 1K OHM 1% 1/8W	28480	0757-0280

See introduction to this section for ordering information

Table 6-1. Replaceable Parts(Cont'd)

Reference Designation	HP Part Number	Qty	Description	Mfr Code	Mfr Part Number
A32 R15	0757-0277		R:FXD MET FLM 49.9 OHM 1% 1/8W	28480	0757-0277
A32 R16	0757-0280		R:FXD MET FLM 1K OHM 1% 1/8W	28480	0757-0280
A32 R17	0698-4307		R:FXD FLM 14.3K OHM 1% 1/8W	28480	0698-4307
A32 R18	0757-0393		R:FXD FLM 47.5 OHM 1% 1/8W	28480	0757-0393
A32 K14	0698-4585	3	R:FXD FLM 348 OHM 1% 1/4W	28480	0698-4585
A32 R22	0757-0393		R:FXD FLM 47.5 OHM 1% 1/8W	28480	0757-0393
A32 K23	0698-4480	6	R:FXD MET FLM 15.8K OHM 1% 1/8W	28480	0698-4480
A32 K24	0698-4480		R:FXD MET FLM 15.8K OHM 1% 1/8W	28480	0698-4480
A32 K25	0698-4473	7	R:FXD FLM 8.06K OHM 1% 1/8W	28480	0698-4473
A32 K26	0698-4473		R:FXD FLM 8.06K OHM 1% 1/8W	28480	0698-4473
A32 K27	0698-4539		R:FXD MET FLM 402K OHM 1% 1/8W	19701	MF4C-1/8 TO-4023-F
A32 K28	0757-0393		R:FXD FLM 47.5 OHM 1% 1/8W	28480	0757-0393
A32 K29	0698-4307		R:FXD FLM 14.3K OHM 1% 1/8W	28480	0698-4307
A32 R30	0698-4595	3	R:FXD FLM 523 OHM 1% 1/4W	28480	0698-4595
A32 K31	0698-4451		R:FXD FLM 340 OHM 1% 1/8W	28480	0698-4451
A32 R32	0757-0393		R:FXD FLM 47.5 OHM 1% 1/8W	28480	0757-0393
A32 R33	0698-4452		R:FXD FLM 374 OHM 1% 1/8W	28480	0698-4452
A32 R36	0757-0393		R:FXD FLM 47.5 OHM 1% 1/8W	28480	0757-0393
A32 R37	0757-0409	3	R:FXD MET FLM 274 OHM 1% 1/8W	28480	0757-0409
A32 R38	0757-0393		R:FXD FLM 47.5 OHM 1% 1/8W	28480	0757-0393
A32 R39	0698-4452		R:FXD FLM 374 OHM 1% 1/8W	28480	0698-4452
A32 R40	0757-0284	6	R:FXD MET FLM 150 OHM 1% 1/8W	28480	0757-0284
A32 K41	0757-0389		R:FXD MET FLM 33.2 OHM 1% 1/8W	28480	0757-0389
A32 K42	0757-0346		R:FXD MET FLM 10 OHM 1% 1/8W	28480	0757-0346
A32 K43	0757-0346		R:FXD MET FLM 10 OHM 1% 1/8W	28480	0757-0346
A32 K44	0757-0389		R:FXD MET FLM 33.2 OHM 1% 1/8W	28480	0757-0389
A32 K45	0757-0284		R:FXD MET FLM 150 OHM 1% 1/8W	28480	0757-0284
A32 R47	0757-0437	2	R:FXD MET FLM 4750 OHM 1% 1/8W	28480	0757-0437
A32 K48	0698-6774		R:FXD FLM 150 OHM 0.1% 1/8W	28480	0698-6774
A32 K49	0698-6774		R:FXD FLM 150 OHM 0.1% 1/8W	28480	0698-6774
A32 K51	0757-0437		R:FXD MET FLM 4750 OHM 1% 1/8W	28480	0757-0437
A32 B (B ONLY)	03330-66527	1	PC ASSY:OUTPUT AMPLIFIER BOARD	28480	03330-66527
A32 C1	0160-2198		C:FXD MICA 20 PF 5%	72136	RDM15C200J3C
A32 C2	0160-0990		C:FXD MICA 100 PF 2% 300VDCW	00853	RDM15F101G3S
A32 C3	0160-2203		C:FXD MICA 91 PF 5%	72136	RDM15F910J3C
A32 C4	0160-0194		C:FXD MY 0.015 UF 10%	56289	192P15392-PTS
A32 C5	0140-0218		C:FXD MICA 160 PF 2%	28480	0140-0218
A32 C6	0160-0958		C:FXD MICA 390 PF 5% 300VDCW	00853	RDM15F391J3S
A32 C7	0160-2209		C:FXD MICA 360 PF 5%	72136	RDM15F361J3C
A32 C8	0140-0206		C:FXD MICA 270 PF 5%	72136	RDM15F2715 500V
A32 C9	0160-0128		C:FXD CER 2.2 UF 20% 25VDCW	56289	5C152C25-CML
A32 C10	0160-0128		C:FXD CER 2.2 UF 20% 25VDCW	56289	5C152C25-CML
A32 C11	0150-0093		C:FXD CER 0.01 UF +80-20% 100VDCW	72982	801-K800011
A32 C12	0150-0093		C:FXD CER 0.01 UF +80-20% 100VDCW	72982	801-K800011
A32 C13	0170-0079		C:FXD MY 0.047UF 20% 50VDCW	84411	STYLE 3 TYPE 601PE
A32 C14	0160-0990		C:FXD MICA 100 PF 2% 300VDCW	00853	RDM15F101G3S
A32 C15	0160-0127		C:FXD CER 1.0 UF 20% 25VDCW	56289	5C13CS-CML
A32 C16	0160-2605		C:FXD CER 0.02 MFD +80-20% 25VDCW	72982	5835000-Y5U 203Z
A32 C17	0150-0084		C:FXD CER 0.1 UF +80-20% 100VDCW	72982	8131-100-651-104Z
A32 C18	0150-0084		C:FXD CER 0.1 UF +80-20% 100VDCW	72982	8131-100-651-104Z
A32 C19	0150-0084		C:FXD CER 0.1 UF +80-20% 100VDCW	72982	8131-100-651-104Z
A32 C20			NOT ASSIGNED		
A32 C21	0180-0104		C:FXD ELECT 200 UF +75-10% 15VDCW	56289	30D207G0150F4-DSM
A32 C22	0160-0128		C:FXD CER 2.2 UF 20% 25VDCW	56289	5C152C25-CML
A32 C23	0160-0128		C:FXD CER 2.2 UF 20% 25VDCW	56289	5C152C25-CML
A32 C24			NOT ASSIGNED		
A32 C25	0150-0084		C:FXD CER 0.1 UF +80-20% 100VDCW	72982	8131-100-651-104Z
A32 C26			NOT ASSIGNED		
A32 C27	0180-0104		C:FXD ELECT 200 UF +75-10% 15VDCW	56289	30D207G0150F4-DSM
A32 C28	0180-1746		C:FXD ELECT 15 UF 10% 20VDCW	28480	0180-1746
A32 C29	0180-1746		C:FXD ELECT 15 UF 10% 20VDCW	28480	0180-1746
A32 CK1	1901-0040		DIODE:SILICON 30MA 30WV	07263	FDG1088
A32 CK2	1901-0040		DIODE:SILICON 30MA 30WV	07263	FDG1088
A32 CK3	1901-0040		DIODE:SILICON 30MA 30WV	07263	FDG1088
A32 CK4	1901-0040		DIODE:SILICON 30MA 30WV	07263	FDG1088
A32 CK5	1901-0040		DIODE:SILICON 30MA 30WV	07263	FDG1088
A32 CK6	1901-0040		DIODE:SILICON 30MA 30WV	07263	FDG1088
A32 CK7	1901-0040		DIODE:SILICON 30MA 30WV	07263	FDG1088
A32 CR8	1902-0025		DIODE,BREAKDOWN:10.0V 5% 400 MW	28480	1902-0025
A32 CR9	1901-0040		DIODE:SILICON 30MA 30WV	07263	FDG1088
A32 CR10	1902-0025		DIODE,BREAKDOWN:10.0V 5% 400 MW	28480	1902-0025
A32 CR11	1901-0040		DIODE:SILICON 30MA 30WV	07263	FDG1088
A32 IC1	1826-0043		IC:LINEAR OPERATIONAL AMPLIFIER	28480	1826-0043
A32 K1	0490-0753	1	REED:SWITCH	28480	0490-0753
A32 K11	0490-1025	1	RELAY:REED 6 FORM A CONTACT	71482	PR68-3004

See introduction to this section for ordering information

Table 6-1. Replaceable Parts(Cont'd)

Reference Designation	HP Part Number	Qty	Description	Mfr Code	Mfr Part Number
A32 L1	9100-3319	2	COIL:FXD 0.74 UH	28480	9100-3319
A32 L2	9100-3318		COIL:FXD 0.58 UH	28480	9100-3318
A32 L3	9100-3318		COIL:FXD 0.58 UH	28480	9100-3318
A32 L4	9100-1627		COIL/CHOKE 39 UH 5%	82142	15-1315-2J
A32 L5	9140-0107		COIL:FXD RF 27 UH 10%	99800	1840-38
A32 L6	9140-0107		COIL:FXD RF 27 UH 10%	99800	1840-38
A32 P1	1250-1339		CONNECTOR:COAX RF SUBMINIATURE	98291	52-051-0000
A32 P2	1250-1195		CONNECTOR:RF SUB-MINIATURE SERIES	98291	52-053-0000
A32 Q1	1854-0345		TSTR:SI NPN	80131	2N5179
A32 Q2	1854-0345		TSTR:SI NPN	80131	2N5179
A32 Q3	1853-0203		TSTR:SI PNP	28480	1853-0203
A32 Q4	1854-0019		TSTR:SI NPN	28480	1854-0019
A32 Q5	1854-0053		TSTR:SI NPN	80131	2N2218
A32 Q6	1854-0345		TSTR:SI NPN	80131	2N5179
A32 Q7	1853-0203		TSTR:SI PNP	28480	1853-0203
A32 Q8	1853-0012		TSTR:SI PNP	80131	2N2904A
A32 Q9	1853-0010		TSTR:SI PNP(SELECTED FROM 2N3251)	28480	1853-0010
A32 R1	0698-8177		R:FXD FLM 1.5 OHM 5% 1/4W	28480	0698-8177
A32 R2	0698-4464		R:FXD FLM 887 OHM 1% 1/8W	28480	0698-4464
A32 R3	0698-8177		R:FXD FLM 1.5 OHM 5% 1/4W	28480	0698-8177
A32 R4	0698-4354		R:FXD FLM 11.8 OHM 1% 1/8W	28480	0698-4354
A32 R5	0698-3441		R:FXD MET FLM 215 OHM 1% 1/8W	28480	0698-3441
A32 R6	0757-0395		R:FXD MET FLM 56.2 OHM 1% 1/8W	28480	0757-0395
A32 R7	0698-3443		R:FXD MET FLM 287 OHM 1% 1/8W	28480	0698-3443
A32 R8	0757-0280		R:FXD MET FLM 1K OHM 1% 1/8W	28480	0757-0280
A32 R9	0757-0393		R:FXD FLM 47.5 OHM 1% 1/8W	28480	0757-0393
A32 R10	0757-0739		R:FXD MET FLM 2.00K OHM 1% 1/4W	28480	0757-0739
A32 R11	0757-0393		R:FXD FLM 47.5 OHM 1% 1/8W	28480	0757-0393
A32 R12	0757-0739		R:FXD MET FLM 2.00K OHM 1% 1/4W	28480	0757-0739
A32 R13	0757-0378		R:FXD MET FLM 11.0 OHM 1% 1/8W	28480	0757-0378
A32 R14	0757-0280		R:FXD MET FLM 1K OHM 1% 1/8W	28480	0757-0280
A32 R15	0757-0277		R:FXD MET FLM 49.9 OHM 1% 1/8W	28480	0757-0277
A32 R16	0757-0280		R:FXD MET FLM 1K OHM 1% 1/8W	28480	0757-0280
A32 R17	0698-4307		R:FXD FLM 14.3K OHM 1% 1/8W	28480	0698-4307
A32 R18	0757-0393		R:FXD FLM 47.5 OHM 1% 1/8W	28480	0757-0393
A32 R19	0698-4585		R:FXD FLM 348 OHM 1% 1/4W	28480	0698-4585
A32 R20			NOT ASSIGNED		
A32 R21			NOT ASSIGNED		
A32 R22	0757-0393		R:FXD FLM 47.5 OHM 1% 1/8W	28480	0757-0393
A32 R23	0698-4480		R:FXD MET FLM 15.8K OHM 1% 1/8W	28480	0698-4480
A32 R24	0698-4480		R:FXD MET FLM 15.8K OHM 1% 1/8W	28480	0698-4480
A32 R25	0698-4473		R:FXD FLM 8.06K OHM 1% 1/8W	28480	0698-4473
A32 R26	0698-4473		R:FXD FLM 8.06K OHM 1% 1/8W	28480	0698-4473
A32 R27	0698-4539		R:FXD MET FLM 402K OHM 1% 1/8W	19701	MF4C-1/8-T0-4023-F
A32 R28	0757-0393		R:FXD FLM 47.5 OHM 1% 1/8W	28480	0757-0393
A32 R29	0698-4307		R:FXD FLM 14.3K OHM 1% 1/8W	28480	0698-4307
A32 R30	0698-4595		R:FXD FLM 523 OHM 1% 1/4W	28480	0698-4595
A32 R31	0698-4451		R:FXD FLM 340 OHM 1% 1/8W	28480	0698-4451
A32 R32	0757-0393		R:FXD FLM 47.5 OHM 1% 1/8W	28480	0757-0393
A32 R33	0698-4452		R:FXD FLM 374 OHM 1% 1/8W	28480	0698-4452
A32 R34			NOT ASSIGNED		
A32 R35			NOT ASSIGNED		
A32 R36	0757-0393		R:FXD FLM 47.5 OHM 1% 1/8W	28480	0757-0393
A32 R37	0757-0409		R:FXD MET FLM 274 OHM 1% 1/8W	28480	0757-0409
A32 R38	0757-0393		R:FXD FLM 47.5 OHM 1% 1/8W	28480	0757-0393
A32 R39	0698-4452		R:FXD FLM 374 OHM 1% 1/8W	28480	0698-4452
A32 R40	0757-0284		R:FXD MET FLM 150 OHM 1% 1/8W	28480	0757-0284
A32 R41	0757-0389		R:FXD MET FLM 33.2 OHM 1% 1/8W	28480	0757-0389
A32 R42	0757-0346		R:FXD MET FLM 10 OHM 1% 1/8W	28480	0757-0346
A32 R43	0757-0346		R:FXD MET FLM 10 OHM 1% 1/8W	28480	0757-0346
A32 R44	0757-0389		R:FXD MET FLM 33.2 OHM 1% 1/8W	28480	0757-0389
A32 R45	0757-0284		R:FXD MET FLM 150 OHM 1% 1/8W	28480	0757-0284
A32 R46			NOT ASSIGNED		
A32 R47	0757-0437		R:FXD MET FLM 4750 OHM 1% 1/8W	28480	0757-0437
A32 R48	0698-7448	4	R:FXD FLM 100 OHM 0.1% 1/4W	28480	0698-7448
A32 R49	0698-7448		R:FXD FLM 100 OHM 0.1% 1/4W	28480	0698-7448
A32 R50	0698-8005		R:FXD MET FLM 75 OHM 0.1% 0.1W	28480	0698-8005
A32 R51	0757-0437		R:FXD MET FLM 4750 OHM 1% 1/8W	28480	0757-0437
A32 R52	0698-4479		R:FXD FLM 14K OHM 1% 1/8W	28480	0698-4479
A32 R53	0757-0280		R:FXD MET FLM 1K OHM 1% 1/8W	28480	0757-0280
A32A (A ONLY)	03330-66572	1	PC ASSY:OUTPUT AMPLIFIER BOARD	28480	03330-66572
A32 C1	0160-2198		C:FXD MICA 20 PF 5%	72136	RDML5C200J3C
A32 C2	0160-0990		C:FXD MICA 100 PF 5% 300VDCW	00853	RDML5F101G3S
A32 C3	0160-2203		C:FXD MICA 91 PF 5%	72136	RDML5F910J3C
A32 C4	0160-0194		C:FXD MY 0.015 UF 10%	56289	192P15392-PTS

See introduction to this section for ordering information

Table 6-1. Replaceable Parts(Cont'd)

Reference Designation	HP Part Number	Qty	Description	Mfr Code	Mfr Part Number
A32 C5	0140-0218		C:FXD MICA 160 PF 2%	28480	0140-0218
A32 C6	0160-0958		C:FXD MICA 390 PF 5% 300VDCW	00853	RDM15F391J3S
A32 C7	0160-2209		C:FXD MICA 360 PF 5%	72136	RDM15F361J3C
A32 C8	0140-0206		C:FXD MICA 270 PF 5%	72136	RDM15F2715 500V
A32 C9	0160-0128		C:FXD CER 2.2 UF 20% 25VDCW	56289	5C152C25-CML
A32 C10	0160-0128		C:FXD CER 2.2 UF 20% 25VDCW	56289	5C152C25-CML
A32 C11	0150-0093		C:FXD CER 0.01 UF +80-20% 100VDCW	72982	801-K800011
A32 C12	0150-0093		C:FXD CER 0.01 UF +80-20% 100VDCW	72982	801-K800011
A32 C13	0170-0079		C:FXD MY 0.047UF 20% 50VDCW	84411	STYLE 3 TYPE 601PE
A32 C14	0160-0990		C:FXD MICA 100 PF 2% 300VDCW	00853	RDM15F101G3S
A32 C15	0160-0127		C:FXD CER 1.0 UF 20% 25VDCW	56289	5C13CS-CML
A32 C16	0160-2605		C:FXD CER 0.02 MFD +80-20% 25VDCW	72982	5835000-Y5U 203Z
A32 C17	0150-0084		C:FXD CER 0.1 UF +80-20% 100VDCW	72982	8131-100-651-104Z
A32 C18	0150-0084		C:FXD CER 0.1 UF +80-20% 100VDCW	72982	8131-100-651-104Z
A32 C19	0150-0084		C:FXD CER 0.1 UF +80-20% 100VDCW	72982	8131-100-651-104Z
A32 C20			NOT ASSIGNED		
A32 C21	0180-0104		C:FXD ELECT 200 UF +75-10% 15VDCW	56289	300207G015DF4-DSM
A32 C22	0160-0128		C:FXD CER 2.2 UF 20% 25VDCW	56289	5C152C25-CML
A32 C23	0160-0128		C:FXD CER 2.2 UF 20% 25VDCW	56289	5C152C25-CML
A32 C24			NOT ASSIGNED		
A32 C25	0150-0084		C:FXD CER 0.1 UF +80-20% 100VDCW	72982	8131-100-651-104Z
A32 C26			NOT ASSIGNED		
A32 C27	0180-0104		C:FXD ELECT 200 UF +75-10% 15VDCW	56289	300207G015DF4-DSM
A32 C28	0180-1746		C:FXD ELECT 15 UF 10% 20VDCW	28480	0180-1746
A32 C29	0180-1746		C:FXD ELECT 15 UF 10% 20VDCW	28480	0180-1746
A32 CR1	1901-0040		DIODE:SILICON 30MA 30WV	07263	FDG1088
A32 CR2	1901-0040		DIODE:SILICON 30MA 30WV	07263	FDG1088
A32 CR3	1901-0040		DIODE:SILICON 30MA 30WV	07263	FDG1088
A32 CR4	1901-0040		DIODE:SILICON 30MA 30WV	07263	FDG1088
A32 CR5	1901-0040		DIODE:SILICON 30MA 30WV	07263	FDG1088
A32 CR6	1901-0040		DIODE:SILICON 30MA 30WV	07263	FDG1088
A32 CR7	1901-0040		DIODE:SILICON 30MA 30WV	07263	FDG1088
A32 CR8	1902-0025		DIODE,BREAKDOWN:10.0V 5% 400 MW	28480	1902-0025
A32 CR9	1901-0040		DIODE:SILICON 30MA 30WV	07263	FDG1088
A32 CR10	1902-0025		DIODE,BREAKDOWN:10.0V 5% 400 MW	28480	1902-0025
A32 IC1	1826-0043		IC:LINEAR OPERATIONAL AMPLIFIER	28480	1826-0043
A32 L1	9100-3319		COIL:FXD 0.74 UH	28480	9100-3319
A32 L2	9100-3318		COIL:FXD 0.58 UH	28480	9100-3318
A32 L3	9100-3318		COIL:FXD 0.58 UH	28480	9100-3318
A32 L4	9100-1627		COIL/CHUKE 39 UH 5%	82142	15-1315-2J
A32 L5	9140-0107		COIL:FXD RF 27 UH 10%	99800	1840-38
A32 L6	9140-0107		COIL:FXD RF 27 UH 10%	99800	1840-38
A32 P1	1250-1339		CONNECTOR:COAX RF SUBMINIATURE	98291	52-051-0000
A32 Q1	1854-0345		TSTR:SI NPN	80131	2N5179
A32 Q2	1854-0345		TSTR:SI NPN	80131	2N5179
A32 Q3	1853-0203		TSTR:SI PNP	28480	1853-0203
A32 Q4	1854-0019		TSTR:SI NPN	28480	1854-0019
A32 Q5	1854-0053		TSTR:SI NPN	80131	2N2218
A32 Q6	1854-0345		TSTR:SI NPN	80131	2N5179
A32 Q7	1853-0203		TSTR:SI PNP	28480	1853-0203
A32 Q8	1853-0012		TSTR:SI PNP	80131	2N2904A
A32 R1	0698-8177		R:FXD FLM 1.5 OHM 5% 1/4W	28480	0698-8177
A32 R2	0698-4464		R:FXD FLM 887 OHM 1% 1/8W	28480	0698-4464
A32 R3	0698-8177		R:FXD FLM 1.5 OHM 5% 1/4W	28480	0698-8177
A32 R4	0698-4354		R:FXD FLM 11.8 OHM 1% 1/8W	28480	0698-4354
A32 R5	0698-3441		R:FXD MET FLM 215 OHM 1% 1/8W	28480	0698-3441
A32 R6	0757-0395		R:FXD MET FLM 56.2 OHM 1% 1/8W	28480	0757-0395
A32 R7	0698-3443		R:FXD MET FLM 287 OHM 1% 1/8W	28480	0698-3443
A32 R8	0757-0280		R:FXD MET FLM 1K OHM 1% 1/8W	28480	0757-0280
A32 R9	0757-0393		R:FXD FLM 47.5 OHM 1% 1/8W	28480	0757-0393
A32 R10	0757-0739		R:FXD MET FLM 2.00K OHM 1% 1/4W	28480	0757-0739
A32 R11	0757-0393		R:FXD FLM 47.5 OHM 1% 1/8W	28480	0757-0393
A32 R12	0757-0739		R:FXD MET FLM 2.00K OHM 1% 1/4W	28480	0757-0739
A32 R13	0757-0378		R:FXD MET FLM 11.0 OHM 1% 1/8W	28480	0757-0378
A32 R14	0757-0280		R:FXD MET FLM 1K OHM 1% 1/8W	28480	0757-0280
A32 R15	0757-0277		R:FXD MET FLM 49.9 OHM 1% 1/8W	28480	0757-0277
A32 R16	0757-0280		R:FXD MET FLM 1K OHM 1% 1/8W	28480	0757-0280
A32 R17	0698-4307		R:FXD FLM 14.3K OHM 1% 1/8W	28480	0698-4307
A32 R18	0757-0393		R:FXD FLM 47.5 OHM 1% 1/8W	28480	0757-0393
A32 R19	0698-4585		R:FXD FLM 348 OHM 1% 1/4W	28480	0698-4585
A32 R21			NOT ASSIGNED		
A32 R22	0757-0393		R:FXD FLM 47.5 OHM 1% 1/8W	28480	0757-0393
A32 R23	0698-4480		R:FXD MET FLM 15.8K OHM 1% 1/8W	28480	0698-4480
A32 R24	0698-4480		R:FXD MET FLM 15.8K OHM 1% 1/8W	28480	0698-4480
A32 R25	0698-4473		R:FXD FLM 8.06K OHM 1% 1/8W	28480	0698-4473

See introduction to this section for ordering information

Table 6-1. Replaceable Parts(Cont'd)

Reference Designation	HP Part Number	Qty	Description	Mfr Code	Mfr Part Number
A32 R26	0698-4473		R:FXD FLM 8.06K OHM 1% 1/8W	28480	0698-4473
A32 R27	0698-4539		R:FXD MET FLM 402K OHM 1% 1/8W	28480	0698-4539
A32 R28	0757-0393		R:FXD FLM 47.5 OHM 1% 1/8W	28480	0757-0393
A32 R29	0698-4307		R:FXD FLM 14.3K OHM 1% 1/8W	28480	0698-4307
A32 R30	0698-4595		R:FXD FLM 523 OHM 1% 1/4W	28480	0698-4595
A32 R31	0698-4451		R:FXD FLM 340 OHM 1% 1/8W	28480	0698-4451
A32 R32	0757-0393		R:FXD FLM 47.5 OHM 1% 1/8W	28480	0757-0393
A32 R33	0698-4452		R:FXD FLM 374 OHM 1% 1/8W	28480	0698-4452
A32 R34			NOT ASSIGNED		
A32 R35			NOT ASSIGNED		
A32 R36	0757-0393		R:FXD FLM 47.5 OHM 1% 1/8W	28480	0757-0393
A32 R37	0757-0409		R:FXD MET FLM 274 OHM 1% 1/8W	28480	0757-0409
A32 R38	0757-0393		R:FXD FLM 47.5 OHM 1% 1/8W	28480	0757-0393
A32 R39	0698-4452		R:FXD FLM 374 OHM 1% 1/8W	28480	0698-4452
A32 R40	0757-0284		R:FXD MET FLM 150 OHM 1% 1/8W	28480	0757-0284
A32 R41	0757-0389		R:FXD MET FLM 33.2 OHM 1% 1/8W	28480	0757-0389
A32 R42	0757-0346		R:FXD MET FLM 10 OHM 1% 1/8W	28480	0757-0346
A32 R43	0757-0346		R:FXD MET FLM 10 OHM 1% 1/8W	28480	0757-0346
A32 R44	0757-0389		R:FXD MET FLM 33.2 OHM 1% 1/8W	28480	0757-0389
A32 R45	0757-0284		R:FXD MET FLM 150 OHM 1% 1/8W	28480	0757-0284
A32 R46			NOT ASSIGNED		
A32 R47	0757-0437		R:FXD MET FLM 4750 OHM 1% 1/8W	28480	0757-0437
A32 R48	0698-7448		R:FXD FLM 100 OHM 0.1% 1/4W	28480	0698-7448
A32 R49	0698-7448		R:FXD FLM 100 OHM 0.1% 1/4W	28480	0698-7448
A32 R50			NOT ASSIGNED		
A32 R51	0757-0437		R:FXD MET FLM 4750 OHM 1% 1/8W	28480	0757-0437
A32A/B	03330-66564		PC ASSY: OUTPUT AMPLIFIER BOARD (OPTION 005)	28480	03330-66564
A32 C1	0140-0218		C: FXD MICA 160PF 2%	28480	0140-0218
A32 C2	0160-2198		C: FXD MICA 20PF 5%	72136	RDM15C200J3C
A32 C3	0140-0200		C: FXD MICA 390 PF 5%	72136	RDM15F391-J3C
A32 C4	0160-0990		C: FXD MICA 100 PF 2% 300VDCW	00853	RDM15F101G35
A32 C5	0140-0220		C: FXD MICA 200 PF 1% 300VDCW	28480	0140-0220
A32 C6	0140-0218		C: FXD MICA 160 PF 2%	28480	0140-0218
A32 C7	0160-2203		C: FXD MICA 91 PF 5%	72136	RDM15F910J3C
A32 C8	0140-0210		C: FXD MICA 270 PF 5%	28480	0140-0210
A32 C9, C10	0180-0291		C: FXD ELECT 1.0 UF 10% 35VDCW	56289	150D105X9035A2-DYS
A32 C11, C12	0160-0127		C: FXD CER 1.0 UF 20% 25VDCW	56289	5C13CS-CML
A32 C13	0150-0093		C: FXD CER 0.01 UF +80-20% 100VDCW	72982	801-K800611
A32 C14	0180-0376		C: FXD ELECT 0.47 UF 10% 35VDCW	56289	150D474X9035A2-DYS
A32 C15 THRU C18	0180-0291		C: FXD ELECT 1.0 UF 10% 35VDCW	56289	150D105X9035A2-DYS
A32 C19	0150-0042		C: FXD T1 4.7 PF 5% 500VDCW	78488	TYPE GA
A32 C20, C21	0160-0127		C: FXD CER 1.0 UF 20% 25VDCW	56289	5C13CS-CML
A32 C22 THRU C24	0180-0116		C: FXD ELECT 6.8 UF 10% 35VDCW	56289	150D685X9035B2-DYS
A32 C25	0180-0097		C: FXD TA 47 UF 10% 35VDCW	56289	150D476X9035S2-DYS
A32 C26, C27	0180-0116		C: FXD ELEC 6.8 UF 10% 35VDCW	56289	150D685X9035B2-DYS
A32 C28	0180-0376		C: FXD ELECT 0.47 UF 10% 35VDCW	56289	150D474X9035A2-DYS
A32 CR1, CR2	1902-0556		DIODE: BRKDNW 20.0 V 5% 1W	28480	1902-0556
A32 CR3, CR4	1901-0044		DIODE: SI 20MA/1V	28480	1901-0044
A32 CR5 THRU CR8	1901-0040		DIODE: SI 30MA 30WV	07263	F0G1088
A32 CR9 THRU CR12	1901-0044		DIODE: SI 20MA/1V	28480	1901-0044
A32 CR13 THRU CR18	1901-0040		DIODE: SI 30MA 30WV	07263	F0G1088
A32 CR19	1901 0050		DIODE: SI 200MA AT 1V	07263	F0A 6308
A32 CR20, CR21	1902-0556		DIODE: BRKDNW 20.0 V 5% 1W	28480	1902-0556
A32 CR22	1901-0050		DIODE: SI 200MA AT 1V	07263	F0A 6308
A32 CR23, CR24	1902-3205		DIODE: BRKDNW 15.0 V 5%	28480	1902-3205
A32 IC1	1826-0043		IC: LINEAR OPERATIONAL AMPLIFIER	12040	SL12795
A32 L1	9100-3319		COIL: FXD 0.74 UH	28480	9100-3319
A32 L2, L3	9100-3318		COIL: FXD 0.58 UH	28480	9100-3318
A32 L4	9140-0107		COIL: FXD RF 27 UH 10%	99800	1840-38
A32 L5, L6	9140-0137		COIL: FXD RF 1000 UH 5%	28480	9140-0137
A32 L7	9140-0107		COIL: FXD RF 27 UH 10%	99800	1840-38
A32 P1	1250-1339		CONN: COAXIAL SUBMINIATURE 50 OHM	28480	1250-1339
A32 P2	1250-1195		CONN: RF SUBMINIATURE SERIES	98291	52-053-0000
A32 Q1	1853-0010		TSTR: SI PNP (SELECT FROM 2N3251)	28480	1853-0010
A32 Q2, Q3	5080-9041		TSTR: SELECTED	28480	5080-9041
A32 Q4, Q5	5080-9042		TSTR: SELECTED	28480	5080-9042
A32 Q6	1854-0351		TSTR: SI NPN	04713	2N3904
A32 Q7	1853-0312		TSTR: SI PNP	04713	2N5160
A32 Q8, Q9	1854-0531		TSTR: SI NPN	28480	1854-0531
A32 Q10	1853-0312		TSTR: SI PNP	04713	2N5160
A32 Q11	1854-0308		TSTR: SI NPN	80131	2N3553
A32 Q12	1853-0313		TSTR: SI PNP	04713	MM 4019
A32 Q13	1854-0351		TSTR: SI NPN	04713	2N3904

Table 6-1. Replaceable Parts(Cont'd)

Reference Designation	HP Part Number	Qty	Description	Mfr Code	Mfr Part Number
A32 Q14	1854-0039		TSTR: SI NPN	80131	2N3053
A32 Q15	1853-0010		TSTR: SI PNP (SELECT FROM 2N3251)	28480	1853 0010
A32 Q16	1853-0051		TSTR: SI PNP	80131	2N4037
A32 R1	0757-0277		R: FXD MET FLM 49.9 OHM 1% 1/8W	28480	0757-0277
A32 R2	0757-0283		R: FXD MET FLM 2.00K OHM 1% 1/8W	28480	0757-0283
A32 R3	0757-0384		R: FXD FLM 20 OHM 1% 1/8W	28480	0757-0384
A32 R4	0757-0277		R: FXD MET FLM 49.9 OHM 1% 1/8W	28480	0757-0277
A32 R5	0757-0747		R: FXD FLM 5110 OHM 1% 1/4W	28480	0757-0747
A32 R6	0757-0283		R: FXD MET FLM 2.00K OHM 1% 1/8W	28480	0757-0283
A32 R7	0757-0428		R: FXD MET FLM 1.62K OHM 1% 1/8W	28480	0757-0428
A32 R8, R9	0683-0685		R: FXD COMP 6.8 OHM 5% 1/4W	01121	CB 68G5
A32 R10 THRU R12	0757-0277		R: FXD MET FLM 49.9 OHM 1% 1/8W	28480	0757-0277
A32 R13	0757-0760		R: FXD FLM 20K OHM 1% 1/4W	28480	0757-0760
A32 R14	0757-0291		R: FXD FLM 24.9 OHM 1% 1/8W	28480	0757-0291
A32 R15	2100-2060		R: VAR FLM 50 OHM 20% LIN 1/2W	28480	2100-2060
A32 R16, R17	0757-0442		R: FXD MET FLM 10.0K OHM 1% 1/8W	28480	0757-0442
A32 R18	0698-4135		R: FXD MET FLM 8.87K OHM 1.0% 1/2W	28480	0698 4135
A32 R19, R20	0757-0277		R: FXD MET FLM 49.9 OHM 1% 1/8W	28480	0757-0277
A32 R21, R22	0683-0685		R: FXD COMP 6.8 OHM 5% 1/4W	01121	CB 68G5
A32 R23	0757-0277		R: FXD MET FLM 49.9 OHM 1% 1/8W	28480	0757-0277
A32 R24	0757-0428		R: FXD MET FLM 1.62K OHM 1% 1/8W	28480	0757-0428
A32 R25	0757-0283		R: FXD MET FLM 2.00K OHM 1% 1/8W	28480	0757-0283
A32 R26	0757-0747		R: FXD FLM 5110 OHM 1% 1/4W	28480	0757-0747
A32 R27	0757-0277		R: FXD MET FLM 49.9 OHM 1% 1/8W	28480	0757-0277
A32 R28	0757-0384		R: FXD FLM 20 OHM 1% 1/8W	28480	0757-0384
A32 R29	0757-0283		R: FXD MET FLM 2.00K OHM 1% 1/8W	28480	0757-0283
A32 R30	0757-0442		R: FXD MET FLM 10.0K OHM 1% 1/8W	28480	0757-0442
A32 R31	0757-0270		R: FXD MET FLM 249K OHM 1% 1/8W	28480	0757-0270
A32 R32	0757-0442		R: FXD MET FLM 10.0K OHM 1% 1/8W	28480	0757-0442
A32 R33	0757-0280		R: FXD MET FLM 1K OHM 1% 1/8W	28480	0757-0280
A32 R34	0757-0277		R: FXD MET FLM 49.9 OHM 1% 1/8W	28480	0757-0277
A32 R35	0698-3468		R: FXD FLM 1.07K OHM 1.0% 1/4W	01738	CMF 60-1, T-2
A32 R36	0687-1521		R: FXD FLM COMP 1500 OHM 10% 1/2W	01121	EB 1521
A32 R37	0687-1001		R: FXD COMP 10 OHM 10% 1/2W	01121	EB 1001
A32 R38	0698-3259		R: FXD FLM 7.87K OHM 1% 1/8W	28480	0698-3259
A32 R39	0698-7985		R: FXD FLM 2 OHM 5% 1/4W	28480	0698-7985
A32 R40	0684-3321		R: FXD COMP 3300 OHM 10% 1/4W	01121	CB 3321
A32 R41	0757-0277		R: FXD MET FLM 49.9 OHM 1% 1/8W	28480	0757-0277
A32 R42, R43	0698-0001		R: FXD COMP 4.7 OHM 5% 1/2W	01121	EB 47G5
A32 R44 THRU R47	0698-7990		R: FXD MET FLM 200 OHM .01% 1/2W	28480	0698-7990
A32 R48	0698-8008		R: FXD MET FLM 357 OHM 0.1% 1/4W	28480	0698-8008
A32 R49	0698-8009		R: FXD MET FLM 95 OHM 0.1% 0.1W	28480	0698-8009
A32 R50	0698-7985		R: FXD FLM 2 OHM 5% 1/4W	28480	0698-7985
A32 R51	0698-3259		R: FXD FLM 7.87K OHM 1% 1/8W	28480	0698 3259
A32 R52	0687-1521		R: FXD COMP 1500 OHM 10% 1/2W	01121	EB 1521
A32 R53	0687-1001		R: FXD COMP 10 OHM 10% 1/2W	01121	EB 1001
A32 R54	0684-3321		R: FXD COMP 3300 OHM 10% 1/4W	01121	CB 3321
A32 R55, R56	0757-0277		R: FXD MET FLM 49.9 OHM 1% 1/8W	28480	0757-0277
A32 R57, R58	0684-1521		R: FXD COMP 1500 OHM 10% 1/4W	01121	CB 1521
A33	03330-66528	1	PC ASSY:REFERENCE OSCILLATOR BOARD	28480	03330-66528
A33C1	0180-1746		C:FXD ELECT 15 UF 10% 20VDCW	28480	0180-1746
A33C2	0180-1746		C:FXD ELECT 15 UF 10% 20VDCW	28480	0180-1746
A33C3	0180-1746		C:FXD ELECT 15 UF 10% 20VDCW	28480	0180-1746
A33CR1	1901-0040		DIODE:SILICON 30MA 30WV	07263	FDG1088
A33IC1	1826-0043		IC:LINEAR OPERATIONAL AMPLIFIER	28480	1826-0043
A33J1	1251-2969		CONNECTOR:PHONO, SINGLE JACK	27264	15-24-0501
A33J2	1251-2969		CONNECTOR:PHONO, SINGLE JACK	27264	15-24-0501
A33J3	1251-2969		CONNECTOR:PHONO, SINGLE JACK	27264	15-24-0501
A33J4	1251-2969		CONNECTOR:PHONO, SINGLE JACK	27264	15-24-0501
A33J5	1251-2969		CONNECTOR:PHONO, SINGLE JACK	27264	15-24-0501
A33K1	0490-0399	1	RELAY:REED 1200 OHM 12VDC	02116	282-1A-12
A33L1	9140-0107	1	COIL:FXD RF 27 OH 10%	99800	1840-38
A33P1	1251-3132	1	CONNECTOR:UTILITY TYPE 3-CONTACT	12881	A-1840-3-2
A33R1	0698-4474	2	R:FXD FLM 8450 OHM 1% 1/8W	28480	0698-4474
A33R2	0698-4474		R:FXD FLM 8450 OHM 1% 1/8W	28480	0698-4474
A33R3	2100-3204	1	R:VAR COMP 10K OHM 10% LIN 1/4W	28480	2100-3204
A33R4	0757-0442		R:FXD MET FLM 10.0K OHM 1% 1/8W	28480	0757-0442
A33R5	0757-0465		R:FXD MET FLM 100K OHM 1% 1/8W	28480	0757-0465
A33R6	0757-0465		R:FXD MET FLM 100K OHM 1% 1/8W	28480	0757-0465
A33R7	0698-3228		R:FXD MET FLM 49.9K OHM 1% 1/8W	28480	0698-3228
A33R8	0757-0280		R:FXD MET FLM 1K OHM 1% 1/8W	28480	0757-0280
A33SW1	3100-2730	1	SWITCH:ROTARY	28480	3100-2730
A33A1	0410-0457	1	OSCILLATOR (STD, OPTION 001, 004, 005)	28480	0410-0457

Table 6-1. Replaceable Parts(Cont'd)

Reference Designation	HP Part Number	Qty	Description	Mfr Code	Mfr Part Number
A33A1	11452A	1	OSCILLATOR HI-STABILITY(OPT 002)	28480	11452A
A34	03330-66529	1	PC ASSY: REMOTE IN/OUT	28480	03330-66529
A35	03330-66530	1	PC ASSY:30-25 VOLT BOARD	28480	03330-66530
A35C1	0180-0228	6	C:FXD ELECT 22 JF 10% 15VDCW	56289	150D226X901582-DYS
A35C2	0160-0157		C:FXD MY 0.0047 UF 10% 200VDCW	56289	192P47292-PTS
A35C3	0180-0228		C:FXD ELECT 22 UF 10% 15VDCW	56289	150D226X901582-DYS
A35C4	0160-2207	2	C:FXD MICA 300 PF 5%	28480	0160-2207
A35C5	0160-0182	2	C:FXD MICA 47PF 5% 300VDCW	14655	ROM15E470J3S
A35C6	0160-0153		C:FXD MY 0.001 UF 10% 200VDCW	56289	192P10292-PTS
A35C7	0140-0214		C:FXD MICA 60 PF 5%	28480	0140-0214
A35C8	0160-0363		C:FXD MICA 620PF 5%	28480	0160-0363
A35C9	0160-2204		C:FXD MICA 100PF 5%	72136	RDM15F101J3C
A35C10	0160-0153		C:FXD MY 0.001 UF 10% 200VDCW	56289	192P10292-PTS
A35C11	0180-0228		C:FXD ELECT 22 UF 10% 15VDCW	56289	150D226X901582-DYS
A35C12			NOT ASSIGNED		
A35C13	0160-3622		C:FXD CER 0.1 UF +80-20% 100VDCW	72982	8131-100-651-104Z
A35C14	0180-1743		C:FXD .1UF 35V	56289	150D104X9035A2
A35CR1	1902-3306	2	C:FXD MICA 100PF 5%	72136	RDM15F101J3C
A35CR2	1901-0158	18	C:FXD MY 0.001 UF 10% 200VDCW	56289	192P10292-PTS
A35CR3	1901-0158		DIODE:SILICON 0.75A 200 PIV	28480	1901-0158
A35CR4	1902-0041		DIODE:BREAKDOWN 5.11V 5%	04713	SZ10939-98
A35CR5	1902-0041		DIODE:BREAKDOWN 5.11V 5%	04713	SZ10939-98
A35CR6	1901-0158		DIODE:SILICON 0.75A 200 PIV	28480	1901-0158
A35CR7			NOT ASSIGNED		
A35CR8			NOT ASSIGNED		
A35CR9			NOT ASSIGNED		
A35CR10			NOT ASSIGNED		
A35CR11			NOT ASSIGNED		
A35CR12	1901-0158		DIODE:SILICON 0.75A 200 PIV	28480	1901-0158
A35CR13	1901-0040		DIODE:SILICON 30MA 30WV	07263	FDG1088
A35CR14	1901-0040		DIODE:SILICON 30MA 30WV	07263	FDG1088
A35CR15	1902-0792	2	DIODE:T.C. REF. 11.7V 5% 500MW	04713	1N943
A35CR16	1901-0040		DIODE:SILICON 30MA 30WV	07263	FDG1088
A35CR17	1901-0158		DIODE:SILICON 0.75A 200 PIV	28480	1901-0158
A35CR18	1902-3246	2	DIODE BREAKDOWN:21.5V 2% 400MW	28480	1902-3246
A35IC1	1820-0196	6	IC:LINEAR VOLTAGE REGULATOR(INPUT)	28480	1820-0196
A35IC2	1820-0196		IC:LINEAR VOLTAGE REGULATOR(INPUT)	28480	1820-0196
A35IC3	1820-0203	6	IC:OPERATIONAL AMPLIFIER	07263	SL8940
A35IC4			NOT ASSIGNED		
A35IC5	1826-0043		IC:LINEAR OPERATIONAL AMPLIFIER	28480	1826-0043
A35Q1	1854-0087		TSTR:SI NPN	80131	2N3417
A35Q2	1854-0087		TSTR:SI NPN	80131	2N3417
A35Q3	1853-0052	6	TSTR:SI PNP	80131	2N3740
A35Q4	1853-0086		TSTR:SI PNP	80131	2N5087
A35Q5	1853-0086		TSTR:SI PNP	80131	2N5087
A35Q6	1853-0086		TSTR:SI PNP	80131	2N5087
A35Q7	1853-0086		TSTR:SI PNP	80131	2N5087
A35Q8	1853-0052		TSTR:SI PNP	80131	2N3740
A35Q9	1854-0404		TSTR:SI NPN	28480	1854-0404
A35R1	0757-0277		R:FXD MET FLM 49.9 OHM 1% 1/8W	28480	0757-0277
A35R2	0813-0028	2	R:FXD DEPC ALLOY FLM 1 OHM 1% 1/2W	91637	RS1A-T2-1R0-K
A35R3	0683-2735		R:FXD COMP 27K OHM 5% 1/4W	01121	EB 2735
A35R4	0757-0349		R:FXD MET FLM 22.6K OHM 1% 1/8W	28480	0757-0349
A35R5	0698-4471	4	R:FXD FLM 7.15K OHM 1% 1/8W	28480	0698-4471
A35R6	0757-0430		R:FXD MET FLM 2.21K OHM 1% 1/8W	28480	0757-0430
A35R7	0757-0430		R:FXD MET FLM 2.21K OHM 1% 1/8W	28480	0757-0430
A35R8	0757-0277		R:FXD MET FLM 49.9 OHM 1% 1/8W	28480	0757-0277
A35R9	0757-0427		R:FXD MET FLM 1.5K OHM 1% 1/8W	28480	0757-0427
A35R10	0687-2731	6	R:FXD COMP 27K OHM 10% 1/2W	01121	EB 2731
A35R11			NOT ASSIGNED		
A35R12	0757-0277		R:FXD MET FLM 49.9 OHM 1% 1/8W	28480	0757-0277
A35R13	0687-2731		R:FXD COMP 27K OHM 10% 1/2W	01121	EB 2731
A35R14	0757-0430		R:FXD MET FLM 2.21K OHM 1% 1/8W	28480	0757-0430
A35R15	0757-0430		R:FXD MET FLM 2.21K OHM 1% 1/8W	28480	0757-0430
A35R16	0757-0161	2	R:FXD FLM 604 OHM 1% 1/8W	28480	0757-0161
A35R17	0757-0451	4	R:FXD MET FLM 24.3K OHM 1% 1/8W	28480	0757-0451
A35R18	0811-1733	2	R:FXD WW 3 OHM 1% 1W	28480	0811-1733
A35R19	0757-0349		R:FXD MET FLM 22.6K OHM 1% 1/8W	28480	0757-0349
A35R20	0698-3226		R:FXD MET FLM 6.49K OHM 1% 1/8W	28480	0698-3226
A35R21	2100-1758	2	R:VAR WW 1K OHM 5% TYPE V 1W	28480	2100-1758
A35R22	0757-0271	2	R:FXD MET FLM 124K OHM 1% 1/8W	28480	0757-0271
A35R23	0757-0349		R:FXD MET FLM 22.6K OHM 1% 1/8W	28480	0757-0349
A35R24	0698-4471		R:FXD FLM 7.15K OHM 1% 1/8W	28480	0698-4471
A35R25	0757-0277		R:FXD MET FLM 49.9 OHM 1% 1/8W	28480	0757-0277
A35R26	0687-2731		R:FXD COMP 27K OHM 10% 1/2W	01121	EB 2731
A35R27	0812-0095	2	R:FXD WW 2K OHM 3% 3W	01738	RS28-95
A35R28	0757-0458	2	R:FXD MET FLM 51.1K OHM 1% 1/8W	28480	0757-0458
A35R29	0757-0277		R:FXD MET FLM 49.9 OHM 1% 1/8W	28480	0757-0277
A35R30	0698-3279		R:FXD MET FLM 4990 OHM 1% 1/8W	28480	0698-3279

Table 6-1. Replaceable Parts(Cont'd)

Reference Designation	HP Part Number	Qty	Description	Mfr Code	Mfr Part Number
A35K31	0698-4435		R:FXD FLM 2.49K OHM 1% 1/8W	28480	0698-4435
A35K32	0698-0085	2	R:FXD MET FLM 2.61K OHM 1% 1/8W	28480	0698-0085
A35K33	0812-0015	2	R:FXD WW 8 OHM 3% 3W	91637	RS23-95
A35K34	0757-0349		R:FXD MET FLM 22.5K OHM 1% 1/8W	28480	0757-0349
A35K35	0757-0468	2	R:FXD FLM 130K OHM 1% 1/8W	28480	0757-0468
A35R36	0757-0349		R:FXD MET FLM 22.5K OHM 1% 1/8W	28480	0757-0349
A35R37	0698-4442	9	R:FXD MET FLM 4.42K OHM 1% 1/8W	28480	0698-4442
A35R38	0698-4121	4	R:FXD FLM 11.3K OHM 1% 1/8W	28480	0698-4121
A35R39	0813-0009	4	R:FXD WW 125 OHM 3% 4W	28480	0813-0009
A35R40	0811-1335	2	R:FXD WW 11K OHM 3% 3W	28450	0811-1335
A35R41	0811-1336	2	R:FXD WW 13K OHM 3% 3W	28480	0811-1336
A35R42	2100-0806	2	R:VAR WW 5K OHM 5%	28480	2100-0806
A35R43	0698-4509	2	R:FXD FLM 80.5K OHM 1% 1/8W	28480	0698-4509
A35R44	0698-3140	2	R:FXD MET FLM 2.49K OHM 1.0% 1/2W	28480	0698-3140
A35R45	0698-3497		R:FXD FLM 6.04K OHM 1% 1/8W	28480	0698-3497
A35R46	0757-0401		R:FXD MET FLM 100 OHM 1% 1/8W	28480	0757-0401
A35R47	0812-0015		R:FXD WW 8 OHM 3% 3W	91637	RS-23-95
A35R48	0683-4725		R:FXD COMP 4700 OHM 5% 1/4W	01121	CB 4725
A35R49	0757-0277		R:FXD MET FLM 49.9 OHM 1% 1/8W	28480	0757-0277
A35R50	0813-0009		R:FXD WW 125 OHM 3% 4W	28480	0813-0009
A35R51	0698-4121		R:FXD FLM 11.3K OHM 1% 1/8W	28480	0698-4121
A35	03330-66561	1	PC ASSY:30-25 VOLT BOARD (OPT 004)	28480	03330-66561
A35 C1	0160-0228		C:FXD ELECT 22 UF 10% 15VDCW	56289	150D226X901582-DYS
A35 C2	0160-0157		C:FXD MY 0.0047 UF 10% 200VDCW	56289	192P47292-PTS
A35 C3	0160-0228		C:FXD ELECT 22 UF 10% 15VDCW	56289	150D226X901582-DYS
A35 C4	0160-2207		C:FXD MICA 300 PF 5%	28480	0160-2207
A35 C5	0160-0182		C:FXD MICA 47PF 5% 300VDCW	14655	RDM15E470J35
A35 C6	0160-0153		C:FXD MY 0.001 UF 10% 200VDCW	56289	192P10292-PTS
A35 C7	0140-0214		C:FXD MICA 60 PF 5%	28480	0140-0214
A35 C8	0160-0363		C:FXD MICA 620PF 5%	28480	0160-0363
A35 C9	0160-2204		C:FXD MICA 100PF 5%	72136	RDM15F101J3C
A35 C10	0160-0153		C:FXD MY 0.001 UF 10% 200VDCW	56289	192P10292-PTS
A35 C11	0160-0228		C:FXD ELECT 22 UF 10% 15VDCW	56289	150D226X901582-DYS
A35 C12	0180-2398	1	C:FXD AL ELECT 600 UF +75-10% 15VDCW	56289	3808076015EL4
A35 C13	0160-3622		C:FXD CER 0.1 UF +80-20% 100VDCW	72082	8131 100 651-104Z
A35 C14 Δ2	0180-1743		C:FXD .1UF 35V	56289	150D104X9035A2
A35 CR1	1902-3306		DIODE BREAKDOWN:36.5V 5% 400MW	28480	1902-3306
A35 CR2	1901-0158		DIODE:SILICON 0.75A 200 PIV	28480	1901-0158
A35 CR3	1901-0158		DIODE:SILICON 0.75A 200 PIV	28480	1901-0158
A35 CR4	1902-0041		DIODE:BREAKDOWN 5.11V 5%	04713	S710939-98
A35 CR5	1902-0041		DIODE:BREAKDOWN 5.11V 5%	04713	S710939-98
A35 CR6	1901-0158		DIODE:SILICON 0.75A 200 PIV	28480	1901-0158
A35 CR7	1901-0158		DIODE:SILICON 0.75A 200 PIV	28480	1901-0158
A35 CR8	1901-0158		DIODE:SILICON 0.75A 200 PIV	28480	1901-0158
A35 CR9	1901-0158		DIODE:SILICON 0.75A 200 PIV	28480	1901-0158
A35 CR10	1901-0158		DIODE:SILICON 0.75A 200 PIV	28480	1901-0158
A35 CR11			NOT ASSIGNED		
A35 CR12	1901-0158		DIODE:SILICON 0.75A 200 PIV	28480	1901-0158
A35 CR13	1901-0040		DIODE:SILICON 30MA 30WV	07263	F0G1088
A35 CR14	1901-0040		DIODE:SILICON 30MA 30WV	07263	F0G1088
A35 CR15	1902-0792		DIODE:T.C. REF. 11.7V 5% 500MW	04713	1N943
A35 CR16	1901-0040		DIODE:SILICON 30MA 30WV	07263	F0G1088
A35 CR17	1901-0158		DIODE:SILICON 0.75A 200 PIV	28480	1901-0158
A35 CR18	1902-3246		DIODE BREAKDOWN:21.5V 2% 400MW	28480	1902-3246
A35 IC1	1820-0196		IC:LINEAR VOLTAGE REGULATOR(INPUT)	28480	1820-0196
A35 IC2	1820-0196		IC:LINEAR VOLTAGE REGULATOR(INPUT)	28480	1820-0196
A35 IC3	1820-0203		IC:OPERATIONAL AMPLIFIER	07263	SL8940
A35 IC4	1820-0430	1	IC:LINEAR, VOLTAGE REGULATOR 5V	28480	1820-0430
A35 IC5	1826-0043		IC:LINEAR OPERATIONAL AMPLIFIER	28480	1826-0043
A35 Q1	1854-0087		TSTR:SI NPN	80131	2N3417
A35 Q2	1854-0087		TSTR:SI NPN	80131	2N3417
A35 Q3	1853-0052		TSTR:SI PNP	80131	2N3740
A35 Q4	1853-0086		TSTR:SI PNP	80131	2N5087
A35 Q5	1853-0086		TSTR:SI PNP	80131	2N5087
A35 Q6	1853-0086		TSTR:SI PNP	80131	2N5087
A35 Q7	1853-0086		TSTR:SI PNP	80131	2N5087
A35 Q8	1853-0052		TSTR:SI PNP	80131	2N3740
A35 Q9	1854-0404		TSTR:SI NPN	28480	1854-0404
A35 R1	0757-0277		R:FXD MET FLM 49.9 OHM 1% 1/8W	28480	0757-0277
A35 R2 Δ7	0813-0028		R:FXD DEPC ALLOY FLM 1 OHM 1% 1/2W	91637	RS1A-T2 1R0-K
A35 R3	0683-2735		R:FXD COMP 27K OHM 5% 1/4W	01121	CB 2735
A35 R4	0757-0349		R:FXD MET FLM 22.6K OHM 1% 1/8W	28480	0757-0349
A35 R5	0698-4471		R:FXD FLM 7.15K OHM 1% 1/8W	28480	0698-4471
A35 R6	0757-0430		R:FXD MET FLM 2.21K OHM 1% 1/8W	28480	0757-0430
A35 R7	0757-0430		R:FXD MET FLM 2.21K OHM 1% 1/8W	28480	0757-0430
A35 R8	0757-0277		R:FXD MET FLM 49.9 OHM 1% 1/8W	28480	0757-0277
A35 R9	0698-4445	1	R:FXD FLM 5.76K OHM 1% 1/8W	28480	0698-4445
A35 R10	0687-2731		R:FXD COMP 27K OHM 10% 1/2W	01121	EB 2731
A35 R11			NOT ASSIGNED		
A35 R12	0757-0277		R:FXD MET FLM 49.9 OHM 1% 1/8W	28480	0757-0277

Table 6-1. Replaceable Parts(Cont'd)

Reference Designation	HP Part Number	Qty	Description	Mfr Code	Mfr Part Number
A35 R13	0687-2731		R:FXD COMP 27K OHM 10% 1/2W	01121	EB 2731
A35 R14	0757-0430		R:FXD MET FLM 2.21K OHM 1% 1/8W	28480	0757-0430
A35 R15	0757-0430		R:FXD MET FLM 2.21K OHM 1% 1/8W	28480	0757-0430
A35 R16	0757-0161		R:FXD FLM 604 OHM 1% 1/8W	28480	0757-0161
A35 R17	0757-0451		R:FXD MET FLM 24.3K OHM 1% 1/8W	28480	0757-0451
A35 R18	0811-1733		R:FXD WW 3 OHM 1% 1W	28480	0811-1733
A35 R19	0757-0349		R:FXD MET FLM 22.6K OHM 1% 1/8W	28480	0757-0349
A35 R20	0698-3226		R:FXD MET FLM 6.49K OHM 1% 1/8W	28480	0698-3226
A35 R21	2100-1758		R:VAR WW 1K OHM 5% TYPE V 1W	28480	2100-1758
A35 R22	0757-0271		R:FXD MET FLM 124K OHM 1% 1/8W	28480	0757-0271
A35 R23	0757-0349		R:FXD MET FLM 22.6K OHM 1% 1/8W	28480	0757-0349
A35 R24	0698-4471		R:FXD FLM 7.15K OHM 1% 1/8W	28480	0698-4471
A35 R25	0757-0277		R:FXD MET FLM 49.9 OHM 1% 1/8W	28480	0757-0277
A35 R26	0687-2731		R:FXD COMP 27K OHM 10% 1/2W	01121	EB 2731
A35 R27	0812-0095		R:FXD WW 2K OHM 3% 3W	01738	RS28-95
A35 R28	0757-0458		R:FXD MET FLM 51.1K OHM 1% 1/8W	28480	0757-0458
A35 R29	0757-0277		R:FXD MET FLM 49.9 OHM 1% 1/8W	28480	0757-0277
A35 R30	0698-3279		R:FXD MET FLM 4990 OHM 1% 1/8W	28480	0698-3279
A35 R31	0698-4435		R:FXD FLM 2.49K OHM 1% 1/8W	28480	0698-4435
A35 R32	0698-0085		R:FXD MET FLM 2.61K OHM 1% 1/8W	28480	0698-0085
A35 R33	0812-0015	2	R:FXD WW 8 OHM 3% 3W	28480	0812-0015
A35 R34	0757-0349		R:FXD MET FLM 22.6K OHM 1% 1/8W	28480	0757-0349
A35 R35	0757-0468		R:FXD FLM 130K OHM 1% 1/8W	28480	0757-0468
A35 R36	0757-0349		R:FXD MET FLM 22.6K OHM 1% 1/8W	28480	0757-0349
A35 R37	0698-4442		R:FXD MET FLM 4.42K OHM 1% 1/8W	28480	0698-4442
A35 R38	0698-4121		R:FXD FLM 11.3K OHM 1% 1/8W	28480	0698-4121
A35 R39	0813-0009		R:FXD WW 125 OHM 3% 4W	28480	0813-0009
A35 R40	0811-1335		R:FXD WW 11K OHM 3% 3W	28480	0811-1335
A35 R41	0811-1336		R:FXD WW 13K OHM 3% 3W	28480	0811-1336
A35 R42	2100-0806		R:VAR WW 5K OHM 5%	28480	2100-0806
A35 R43	0698-4509		R:FXD FLM 80.6K OHM 1% 1/8W	28480	0698-4509
A35 R44	0698-3140		R:FXD MET FLM 2.49K OHM 1.0% 1/2W	28480	0698-3140
A35 R45	0698-3497		R:FXD FLM 6.04K OHM 1% 1/8W	28480	0698-3497
A35 R46	0757-0401		R:FXD MET FLM 100 OHM 1% 1/8W	28480	0757-0401
A35 R47	0812-0015		R:FXD WW 8 OHM 3% 3W	28480	0812-0015
A35 R48	0683-4725		R:FXD COMP 4700 OHM 5% 1/4W	01121	CB 4725
A35 R49	0757-0277		R:FXD MET FLM 49.9 OHM 1% 1/8W	28480	0757-0277
A35 R50	0813-0009		R:FXD WW 125 OHM 3% 4W	28480	0813-0009
A35 R51	0698-4121		R:FXD FLM 11.3K OHM 1% 1/8W	28480	0698-4121
A36	03330-66531	1	PC ASSY: 15.5 VOLT BOARD	28480	03330-66531
A36C1	0140-0199	2	C:FXD MICA 240 PF 5%	28480	0140-0199
A36C2	0160-0154		C:FXD MICA MY 0.0022 UF 10% 200VDCW	56289	192P22292-PTS
A36C3	0160-0154		C:FXD MICA MY 0.0022 UF 10% 200VDCW	56289	192P22292-PTS
A36C4	0140-0199		C:FXD MICA 240 PF 5%	28480	0140-0199
A36C5	0180-0291		C:FXD ELECT 1.0 UF 10% 35VDCW	56289	150D105X9035A2-DYS
A36C6	0170-0040	1	C:FXD MY 0.047 UF 10% 200VDCW	56289	192P47392-PTS
A36C7	0160-0155		C:FXD MY 0.0033 UF 10% 200VDCW	56289	192P33292-PTS
A36C8	0160-0157		C:FXD MY 0.0047 UF 10% 200VDCW	56289	192P47292-PTS
A36C9	0160-0168		C:FXD MY 0.1 UF 10% 200VDCW	56289	192P10492-PTS
A36C10	0160-0155		C:FXD MY 0.0033 UF 10% 200VDCW	56289	192P33292-PTS
A36C11	0160-0157		C:FXD MY 0.0047 UF 10% 200VDCW	56289	192P47292-PTS
A36C12	0160-3847		C:FXD .01 UF 25V	28480	0160-3847
A36CR1	1901-0040		DIODE:SILICON 30MA 30WV	07263	FDG1088
A36CR2	1901-0158		DIODE:SILICON 0.75A 200 PIV	28480	1901-0158
A36CR3	1901-0158		DIODE:SILICON 0.75A 200 PIV	28480	1901-0158
A36CR4	1901-0040		DIODE:SILICON 30MA 30WV	07263	FDG1088
A36CR5	1901-0040		DIODE:SILICON 30MA 30WV	07263	FDG1088
A36CR6	1884-0213	2	THYRISTOR-SCR	04713	1884-0213
A36CR7	1901-0200	2	DIODE:SILICON 100 PIV 3A	02735	1N4998
A36CR8	1901-0040		DIODE:SILICON 30MA 30WV	07263	FDG1088
A36CR9	1902-0049	2	DIODE:BREAKDOWN 6.19V 5%	04713	SZ10939-122
A36CR10	1901-0158		DIODE:SILICON 0.75A 200 PIV	28480	1901-0158
A36CR11	1901-0040		DIODE:SILICON 30MA 30WV	07263	FDG1088
A36CR12	1884-0213		THYRISTOR-SCR	04713	1884-0213
A36CR13	1901-0200		DIODE:SILICON 100 PIV 3A	02735	1N4998
A36CR14	1902-0049		DIODE:BREAKDOWN 6.19V 5%	04713	SZ10939-122
A36CR15	1901-0158		DIODE:SILICON 0.75A 200 PIV	28480	1901-0158
A36CR16	1901-0040		DIODE:SILICON 30MA 30WV	07263	FDG1088
A36F1	2110-0417	2	FUSE:10 AMP AT 130V	71400	G88-10
A36F2	2110-0417		FUSE:10 AMP AT 130V	71400	G88-10
A36IC1	1820-0203		IC:OPERATIONAL AMPLIFIER	07263	SL8940
A36IC2	1820-0203		IC:OPERATIONAL AMPLIFIER	07263	SL8940
A36IC3	1820-0196		IC:LINEAR VOLTAGE REGULATOR(INPUT)	28480	1820-0196
A36IC4	1820-0203		IC:OPERATIONAL AMPLIFIER	07263	SL8940
A36IC5	1820-0196		IC:LINEAR VOLTAGE REGULATOR(INPUT)	28480	1820-0196
A36IC6	1820-0203		IC:OPERATIONAL AMPLIFIER	07263	SL8940

Table 6-1. Replaceable Parts(Cont'd)

Reference Designation	HP Part Number	Qty	Description	Mfr Code	Mfr Part Number		
A36Q1	1854-0404	1	TSTR:SI NPN	28480	1854-0404		
A36Q2	1854-0039		TSTR:SI NPN	80131	2N3053		
A36Q3	1853-0086		TSTR:SI PNP	80131	2N5037		
A36Q4	1853-0052		TSTR:SI PNP	80131	2N3740		
A36Q5	1854-0072		TSTR:SI NPN	80131	2N3054		
A36R1	0811-2466	1	R:FXD WW 1.2 OHM 5% 1/2W	28480	0811-2466		
A36R2	0757-0401		R:FXD MET FLM 100 OHM 1% 1/8W	26480	0757-0401		
A36R3	0687-1231		R:FXD COMP 12K OHM 10% 1/2W	01121	E8 1231		
A36R4	0757-0455		R:FXD FLM 36.5K OHM 1% 1/8W	28480	0757-0455		
A36R5	0698-3497		R:FXD FLM 6.04K OHM 1% 1/8W	28480	0698-3497		
A36R6	0698-4442	1	R:FXD MET FLM 4.42K OHM 1% 1/8W	28480	0698-4442		
A36R7	0812-0039		R:FXD WW 2.2 OHM 3% 3W	28480	0812-0039		
A36R8	0698-4457		R:FXD FLM 576 OHM 1% 1/8W	28480	0698-4457		
A36R9	0698-3259		R:FXD FLM 7.87K OHM 1% 1/8W	28480	0698-3259		
A36R10	0757-0346		R:FXD MET FLM 10 OHM 1% 1/8W	28480	0757-0346		
A36R11	0687-1231		R:FXD COMP 12K OHM 10% 1/2W	01121	E8 1231		
A36R12	0757-0401		R:FXD MET FLM 100 OHM 1% 1/8W	28480	0757-0401		
A36R13	0757-0455		R:FXD FLM 36.5K OHM 1% 1/8W	28480	0757-0455		
A36R14	0698-3497		R:FXD FLM 6.04K OHM 1% 1/8W	28480	0698-3497		
A36R15	0698-4473		R:FXD FLM 8.06K OHM 1% 1/8W	28480	0698-4473		
A36R16	0698-3279		R:FXD MET FLM 4990 OHM 1% 1/8W	28480	0698-3279		
A36R17	0757-0446		R:FXD MET FLM 15.0K OHM 1% 1/8W	28480	0757-0446		
A36R18	0698-4123		R:FXD MET FLM 499 OHM 1% 1/8W	28480	0698-4123		
A36R19	0757-0401		R:FXD MET FLM 100 OHM 1% 1/8W	28480	0757-0401		
A36R20	0757-0451		R:FXD MET FLM 24.3K OHM 1% 1/8W	28480	0757-0451		
A36R21	0698-4482	4	R:FXD FLM 17.4K OHM 1% 1/8W	28480	0698-4482		
A36R22	0698-4442		R:FXD MET FLM 4.42K OHM 1% 1/8W	28480	0698-4442		
A36R23			NOT ASSIGNED				
A36R24	0811-1200		R:FXD WW 0.10 OHM 10% 2W	28480	0811-1200		
A36R25	0687-1511		R:FXD COMP 150 OHM 10% 1/2W	01121	E8 1511		
A36R26	0757-0346		R:FXD MET FLM 10 OHM 1% 1/8W	28480	0757-0346		
A36R27	0757-0280		R:FXD MET FLM 1K OHM 1% 1/8W	28480	0757-0280		
A36R28	0698-4442		R:FXD MET FLM 4.42K OHM 1% 1/8W	28480	0698-4442		
A36R29	0698-4442		R:FXD MET FLM 4.42K OHM 1% 1/8W	28480	0698-4442		
A36R30	0698-4123		R:FXD MET FLM 499 OHM 1% 1/8W	28480	0698-4123		
A36R31			NOT ASSIGNED				
A36R32	0757-0466		R:FXD MET FLM 110K OHM 1% 1/8W	28480	0757-0466		
A36R33	0698-3498		R:FXD MET FLM 8.66K OHM 1% 1/8W	28480	0698-3498		
A36R34	0687-1231		R:FXD COMP 12K OHM 10% 1/2W	01121	E8 1231		
A36R35	0698-3615		R:FXD MET OX 47 OHM 5% 2W	28480	0698-3615		
A36R36	0698-4123	1	R:FXD MET FLM 499 OHM 1% 1/8W	28480	0698-4123		
A36R37	0757-0401		R:FXD MET FLM 100 OHM 1% 1/8W	28480	0757-0401		
A36R38	0757-0451		R:FXD MET FLM 24.3K OHM 1% 1/8W	28480	0757-0451		
A36R39	0811-1200		R:FXD WW 0.10 OHM 10% 2W	28480	0811-1200		
A36R40	0811-1200		R:FXD WW 0.10 OHM 10% 2W	28480	0811-1200		
A36R41	0811-1200		R:FXD WW 0.10 OHM 10% 2W	28480	0811-1200		
A36R42	0698-4442		R:FXD MET FLM 4.42K OHM 1% 1/8W	28480	0698-4442		
A36R43	0757-0346		R:FXD MET FLM 10 OHM 1% 1/8W	28480	0757-0346		
A36R44	0757-0280		R:FXD MET FLM 1K OHM 1% 1/8W	28480	0757-0280		
A36R45	0698-4442		R:FXD MET FLM 4.42K OHM 1% 1/8W	28480	0698-4442		
A36R46	0698-4123		1	R:FXD MET FLM 499 OHM 1% 1/8W	28480	0698-4123	
A36R47	0698-4442			R:FXD MET FLM 4.42K OHM 1% 1/8W	28480	0698-4442	
A36R48	0698-4482			R:FXD FLM 17.4K OHM 1% 1/8W	28480	0698-4482	
A36R49	0698-4517			R:FXD FLM 127K OHM 1% 1/8W	28480	0698-4517	
A36R50	0698-3519			R:FXD MET FLM 12.4K OHM 1% 1/8W	28480	0698-3519	
A40	11452A	1		OSCILLATOR: HI STABILITY OPTION 002 (includes the following)	28480	11452A	
A40C1,C2	0180-1794	2		C:FXD 22UF 35V	28480	0180-1794	
A40CR1	1901-0527	1		DIODE:CURRENT REGULATOR	28480	1901-0527	
A40CR2	1902-0018			DIODE:BRKDOWN 11.7V 5%	04713	IN 941	
A40CR3	1902-3073			DIODE:BRKDOWN 4.32V 5%	04713	SZ 10939-77	
A40J1	1251-1633	1		CONN:PC 15 PIN	71785	252-15-30-310	
A40Q1	1854-0071	1		TSTR:SI NPN (selected from 2N3704)	28480	1854-0071	
A40R1,R2	0811-3143	2		R:FXD 10 OHM 1%	28480	0811-3143	
	11452-66501			1	PC ADAPTER	28480	11452-66501
	10544-60011			1	CRYSTAL OSCILLATOR	28480	10544-60011

Table 6-1. Replaceable Parts(Cont'd)

Reference Designation	HP Part Number	Qty	Description	Mfr Code	Mfr Part Number	
CHASSIS MOUNTED COMPONENTS						
C1	0180-2432	2	C:FxD AL ELECT 3000 UF +100-10% 55VDCW	56289	62D10362	
C2	0180-2432		C:FxD AL ELECT 3000 UF +100-10% 55VDCW	56289	62D10362	
C3	0180-2431	2	C:FxD AL ELECT 5000 UF +100-10% 35VDCW	56289	62D10361	
C4	0180-2431		C:FxD AL ELECT 5000 UF +100-10% 35VDCW	56289	62D10361	
C5	0180-2469	1	C:FxD AL ELECT 65000 UF +75-10% 15VDCW	56289	36D7059	
CR1	1901-0526	3	DIODE ASSY:SI 100V	14099	SCAJ1	
CR2	1901-0526		DIODE ASSY:SI 100V	14099	SCAJ1	
CR3	1901-0526		DIODE ASSY:SI 100V	14099	SCAJ1	
CR4	1906-0037	1	DIODE ASSY:SINGLE PHASE F/W BRIDGE	04713	MDA 990-1	
J1	1250-0102	8	CONNECTOR:BNC	28480	1250-0102	
J2	1250-0102		CONNECTOR:BNC	28480	1250-0102	
J3	1250-0102		CONNECTOR:BNC	28480	1250-0102	
J4	1250-0102		CONNECTOR:BNC	28480	1250-0102	
J5	1250-0102		CONNECTOR:BNC	28480	1250-0102	
J6	1250-0102		CONNECTOR:BNC	28480	1250-0102	
J7	1250-0102		CONNECTOR:BNC	28480	1250-0102	
J8	1250-0102		CONNECTOR:BNC	28480	1250-0102	
B1	03330-69501	1	FAN	28480	3160-0259	
Q1	1854-0072		TSTR:SI NPN	80131	2N3054	
Q2	1854-0072		TSTR:SI NPN	80131	2N3054	
Q3	1854-0072		TSTR:SI NPN	80131	2N3054	
Q4	1853-0052		TSTR:SI PNP	80131	2N3740	
Q5	1854-0439	2	TSTR:SI NPN	04713	2N3055	
Q6	1854-0439		TSTR:SI NPN	04713	2N3055	
R1	2100-3267	1	R:VAR 5K OHM (3330A LEVEL)	28480	2100-3267	
S1	3100-2731	1	SWITCH:LINE	28480	3100-2731	
S2 (B ONLY)	3100-2732	1	SWITCH:LEVELING	28480	3100-2732	
S3	3103-0016	1	SWITCH: THERMAL	14604	3450	
T1	9100-3271	1	TRANSFORMER	28480	9100-3271	
T2	9100-3272	1	TRANSFORMER (ISOLATION) (OPTION 004)	28480	9100-3272	
MISCELLANEOUS						
A10	1250-0083	1	CONNECTOR:RF	24931	28JR-130-1	
	0960-0443	1	MODULE:POWER INPUT	28480	0960-0443	
	8120-1538	1	CABLE:AC POWER	28480	8120-1538	
	9320-1632	1	OPERATING CARD	28480	9320-1632	
	0370-1005	1	KNOB: POINTER (REF TUNE)	28480	0370-1005	
	0370-1107	1	KNOB: POINTER BAR (LINE)	28480	0370-1107	
	0370-1099 (B ONLY)	2	KNOB: POINTER (REF OSC)(LEVEL)	28480	0370-1099	
	0370-1099 (A ONLY)	1	KNOB: POINTER (REF OSC)	28480	0370-1099	
	0370-2252	1	KNOB: 1/2 BAR/SKT (KEYBOARD RELEASE)	28480	0370-2252	
	0370-2256 (A ONLY)	1	KNOB: AMPLITUDE	28480	0370-2256	
	0370-2369 (001)(A ONLY)	1	KNOB: AMPLITUDE	28480	0370-2369	
	0370-2370 (005)(A ONLY)	1	KNOB: AMPLITUDE	28480	0370-2370	
	CABLE ASSEMBLIES					
		03330-61606	1	CABLE ASSY: CLEAR	28480	03330-61606
	03330-61607	1	CABLE ASSY: WHITE (8 IN)	28480	03330-61607	
	03330-61608	1	CABLE ASSY: BROWN (9 IN)	28480	03330-61608	
	03330-61609	1	CABLE ASSY: RED	28480	03330-61609	
	03330-61610	1	CABLE ASSY: YELLOW	28480	03330-61610	
	03330-61621	1	CABLE ASSY: VIOLET	28480	03330-61621	
	03330-61612	1	CABLE ASSY: GRAY (7 IN)	28480	03330-61612	
	03330-61613	1	CABLE ASSY: WHITE (10 IN)	28480	03330-61613	
	03330-61614	1	CABLE ASSY: BROWN (10 IN)	28480	03330-61614	
	03330-61615	1	CABLE ASSY: ORANGE	28480	03330-61615	
	03330-61616	1	CABLE ASSY: GREEN	28480	03330-61616	
	03330-61617	1	CABLE ASSY: BLUE	28480	03330-61617	
	03330-61618	1	CABLE ASSY: GRAY (15 IN)	28480	03330-61618	
	03330-61622	1	CABLE ASSY: OPTION 001	28480	03330-61622	

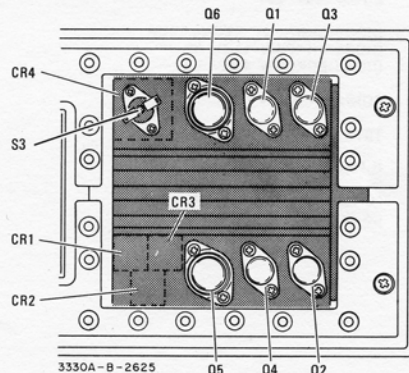

p/o Figure 6-1. Chassis Mounted Components.

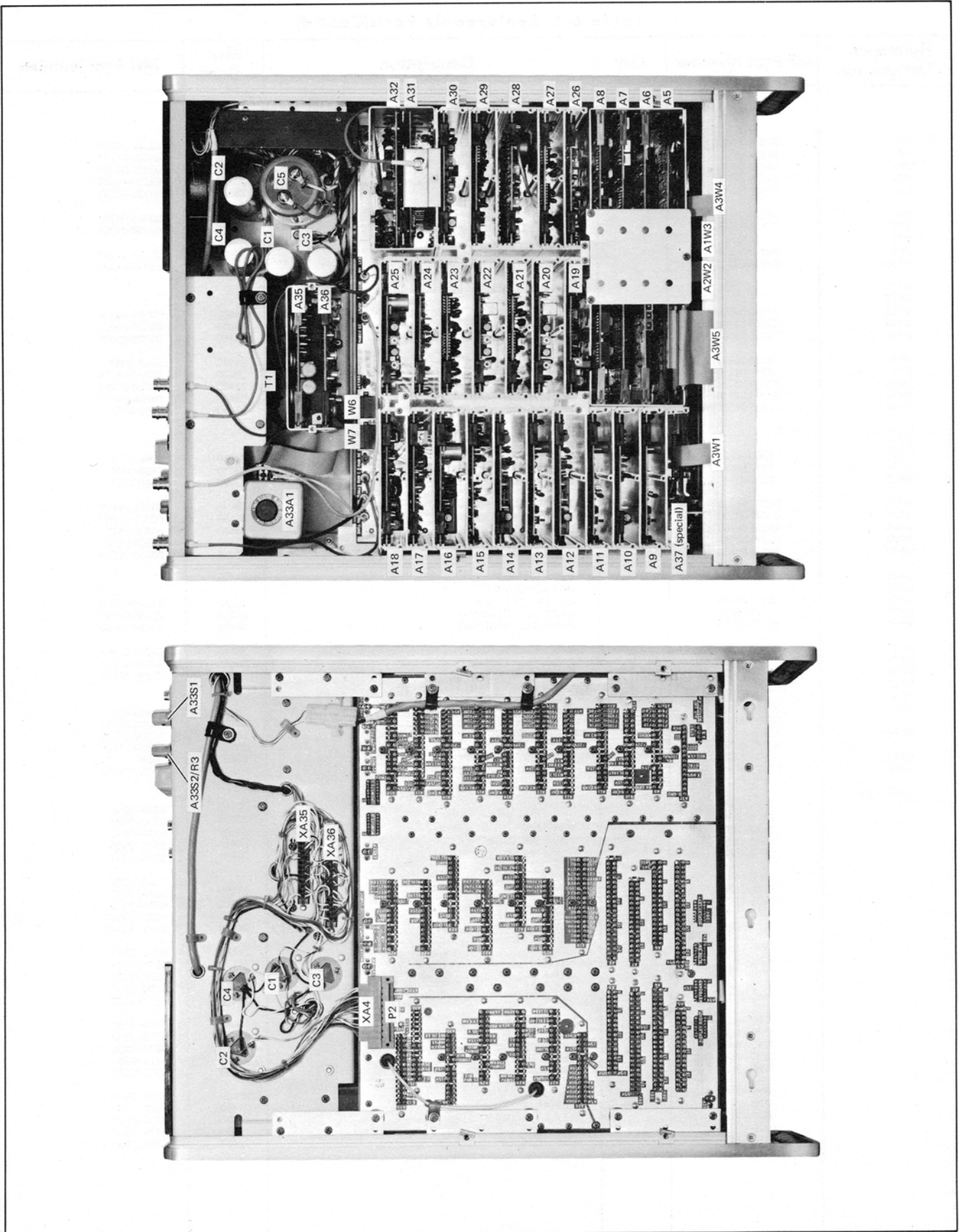

p/o Figure 6-1. Chassis Mounted Components.

Table 6-1. Replaceable Parts(Cont'd)

Reference Designation	HP Part Number	Qty	Description	Mfr Code	Mfr Part Number
MECHANICAL PARTS LIST					
MP1	03330-24703		TRIM:TOP FRONT PANEL	28480	03330-24703
MP2	03330-04117		COVER:TOP	28480	03330-04117
MP3	03330-04101		COVER:CARD NEST	28480	03330-04101
MP4	03330-64108		COVER:CARD NEST	28480	03330-64108
MP5	03330-04102		COVER:CARD NEST	28480	03330-04102
MP6	03330-04103		COVER:CARD NEST	28480	03330-04103
MP7	03330-01204		BRACKET:LEFT FRONT-REAR	28480	03330-01204
MP8			NOT ASSIGNED		
MP9	03330-01206		BRACKET:RIGHT REAR	28480	03330-01206
MP10	03330-01208		BRACKET:RIGHT FRONT	28480	03330-01208
MP11			NOT ASSIGNED		
MP12			NOT ASSIGNED		
MP13	03330-66604		ATTENUATOR ASSY: CONSTRUCTION	28480	03330-66604
MP14	03330-01205		BRACKET:HEAT SINK	28480	03330-01205
MP15	03330-22001		FRAME:SIDE	28480	03330-22001
MP16	5000-0052		TRIM	28480	5000-0052
MP17	03330-04118		COVER:BOTTOM	28480	03330-04118
MP18	03330-01201		BRACKET:MOTHER BOARD	28480	03330-01201
MP19	03330-04115		COVER:RIGHT SIDE	28480	03330-04115
MP20	5060-8735		HANDLE ASSY: RETAINER	28480	5060-8735
MP21			NOT ASSIGNED		
MP22			NOT ASSIGNED		
MP23	5060-0222		HANDLE ASSY	28480	5060-0222
MP24	1490-0030		STAND TILT	28480	1490-0030
MP25	5060-0767		FOOT ASSY	28480	5060-0767
MP26	03330-24710		TRIM:BOTTOM FRONT PANEL	28480	03330-24710
MP27	03330-60202		PLATE:DIGITAL CARD NEST	28480	03330-60202
MP28	03330-24701		SPACER:FRONT PANEL	28480	03330-24701
MP29	03330-04301		TRIM:STRIP	28480	03330-04301
MP30	03330-66603		CARD NEST:DIGITAL	28480	03330-66603
MP31			NOT ASSIGNED		
MP32			NOT ASSIGNED		
MP33	03330-04116		COVER:LEFT SIDE	28480	03330-04116
MP34	03330-26606		CARD NEST SEGMENT	28480	03330-26606
MP35	03330-26603		CARD NEST SEGMENT	28480	03330-26603
MP36	03330-26604		CARD NEST SEGMENT	28480	03330-26604
MP37	03330-26605		CARD NEST SEGMENT	28480	03330-26605
MP38	03330-26607		CARD NEST SEGMENT	28480	03330-26607
MP39			NOT ASSIGNED		
MP40			NOT ASSIGNED		
MP41	03330-09302		LENS DISPLAY (B ONLY)	28480	03330-09302
	03330-09301		LENS DISPLAY (A ONLY)	28480	03330-09301
MP42	03330-24301		PANEL:ANNUNCIATOR (B ONLY)	28480	03330-24301
	03330-24302		PANEL:ANNUNCIATOR (A ONLY)	28480	03330-24302
MP43	0403-0029		BUMPER:RUBBER 1/2"	70485	366W
MP44	03330-04703		SPACER:READOUT SUPPORT	28480	03330-04703
MP45 Δ14			KEYBOARD KEYS (SEE FIGURE 6-3)		
	0370-2940		KEY:FREQ	28480	0370-2940
	0370-2941		KEY:FREQ STEP	28480	0370-2941
	0370-2942		KEY:AMPL	28480	0370-2942
	0370-2928		KEY:AMPL STEP	28480	0370-2928
	0370-2321		KEY:0 (B ONLY)	28480	0370-2321
	0370-2207				0370-2207
	0370-2312		KEY:1	28480	0370-2312
	0370-2313		KEY:2	28480	0370-2313
	0370-2314		KEY:3	28480	0370-2314
	0370-2315		KEY:4	28480	0370-2315
	0370-2929		KEY:5	28480	0370-2929
	0370-2317		KEY:6	28480	0370-2317
	0370-2318		KEY:7	28480	0370-2318
	0370-2319		KEY:8	28480	0370-2319
	0370-2320		KEY:9	28480	0370-2320
	0370-2322		KEY:.(DECIMAL)	28480	0370-2322
	0370-2218				0370-2218
	0370-2930		KEY: + DBM	28480	0370-2930
	0370-2931		KEY: - DBM	28480	0370-2931
	0370-2932		KEY: HZ	28480	0370-2932
	0370-2933		KEY: KHZ	28480	0370-2933
	0370-2934		KEY: MHZ	28480	0370-2934
	0370-2935		KEY:FREQ DIV 2	28480	0370-2935
	0370-2936		KEY:FREQ DIV 10	28480	0370-2936
	0370-2937		KEY:FREQ UP	28480	0370-2937

Table 6-1. Replaceable Parts(Cont'd)

Reference Designation	HP Part Number	Qty	Description	Mfr Code	Mfr Part Number
			KEYBOARD KEYS (CONTINUED)		
	0370-2938		KEY:FREQ X 2	28480	0370-2938
	0370-2939		KEY:FREQ X 10	28480	0370-2939
	0370-2918		KEY:FREQ DN	28480	0370-2918
	0370-2919		KEY:AMPL DIV 2	28480	0370-2919
	0370-2920		KEY:AMPL DIV 10	28480	0370-2920
	0370-2921		KEY:AMPL UP	28480	0370-2921
	0370-2922		KEY:AMPL X 2	28480	0370-2922
	0370-2923		KEY:AMPL X 10	28480	0370-2923
	0370-2924		KEY:AMPL DN	28480	0370-2924
	0370-2925		KEY:1ST POINT	28480	0370-2925
	0370-2926		KEY:START SGL	28480	0370-2926
	0370-2927		KEY:START CONT	28480	0370-2927
	0370-2943		KEY:STOP	28480	0370-2943
MP46	03330-68301		COVER ASSEMBLY:KEYBOARD	28480	03330-68301
MP47			NOT ASSIGNED		
MP48			NOT ASSIGNED		
MP49			NOT ASSIGNED		
MP50	5040-5982		LATCH KEYBOARD	28480	5040-5982
MP51	03330-61202		BRACKET ASSY:LATCH	28480	03330-61202
MP52	1390-0245		LATCH SHAFT	28480	1390-0245
MP53	03330-20203		PANEL:FRONT LEFT (A, B 50 OHM)	28480	03330-20203
	03330-20204		PANEL:FRONT LEFT (A, B 75 OHM)	28480	03330-20204
MP54			NOT ASSIGNED		
MP55	03330-64702		SUPPORT:LOWER PIVOT	28480	03330-64702
MP56	03330-40202		HOUSING:KEYBOARD (B ONLY)	28480	03330-40202
	03330-40201		HOUSING:KEYBOARD (A ONLY)	28480	03330-40201
MP57			NOT ASSIGNED		
MP58	03330-20202		PANEL:FRONT LEFT	28480	03330-20202
MP59			NOT ASSIGNED		
MP60	1250-0102		CONNECTOR:BNC (2 EA.)	28480	1250-0102
MP61	03330-01207		CLAMP:CABLE CONNECTOR	28480	03330-01207
MP62	1460-1325		SPRING:EXTENDER	28480	1460-1325
MP63	03330-61204		BRACKET ASSY:BUSHING	28480	03330-61204
MP64	5040-5980		FOLLOWER:DETENT	28480	5040-5980
MP65	03330-64705		SUPPORT:READOUT	28480	03330-64705
MP66			NOT ASSIGNED		
MP67			NOT ASSIGNED		
MP68			NOT ASSIGNED		
MP69			NOT ASSIGNED		
MP70	03330-04109		COVER:TRANSFORMER SUPPORT	28480	03330-04109
MP71	03330-24708		SUPPORT:TRANSFORMER RIGHT HAND SIDE	28480	03330-24708
MP72	03330-61101		HEAT-SINK ASSY	28480	03330-61101
MP73	03330-04303		PLATE:HOLE TRIM	28480	03330-04303
MP74	03330-69501		FAN:TUBEAXIAL	28480	03330-69501
MP75	09101-04601		SCREEN:FILTER	28480	09101-04601
MP76	3150-0044		FILTER:AIR	28480	3150-0044
MP77	5040-6681		FRAME AIR FILTER	28480	5040-6681
MP78	03330-24702		SPACER:REAR PANEL	28480	03330-24702
MP79	03330-60201		PANEL:REAR	28480	03330-60201
MP80	0180-0078		CLAMP:CAPACITOR MOUNTING	28480	0180-0078
MP81			NOT ASSIGNED		
MP82			NOT ASSIGNED		
MP83	03330-66605		CARD NEST ASSY	28480	03330-66605
MP84	05216-4007		SOCKET:CONNECTOR	28480	05216-4007
MP85	03330-04110		COVER:CARD NEST	28480	03330-04110
MP86	03330-24709		SUPPORT:TRANSFORMER LEFT HAND SIDE	28480	03330-24709

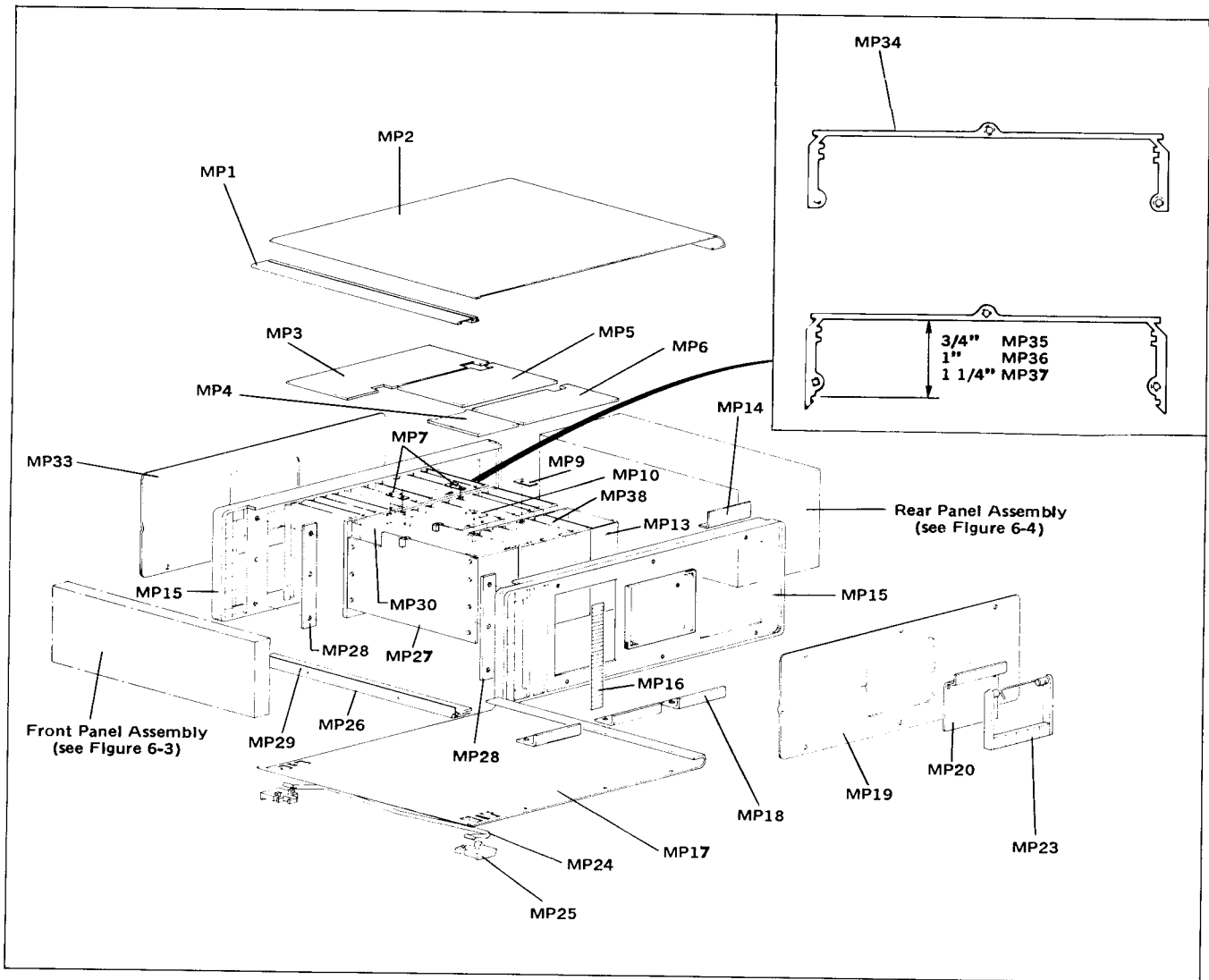

Figure 6-2. Main Assembly Mechanical Parts.

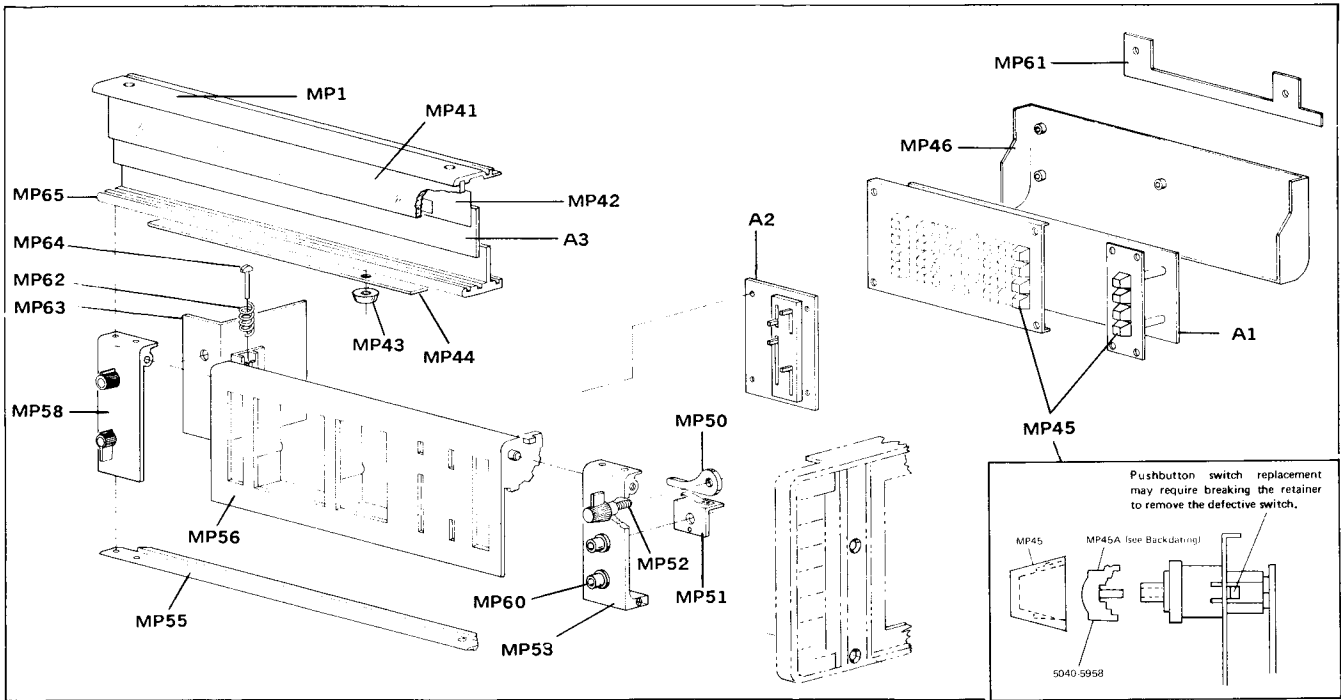

Figure 6-3. Front Panel Mechanical Parts.

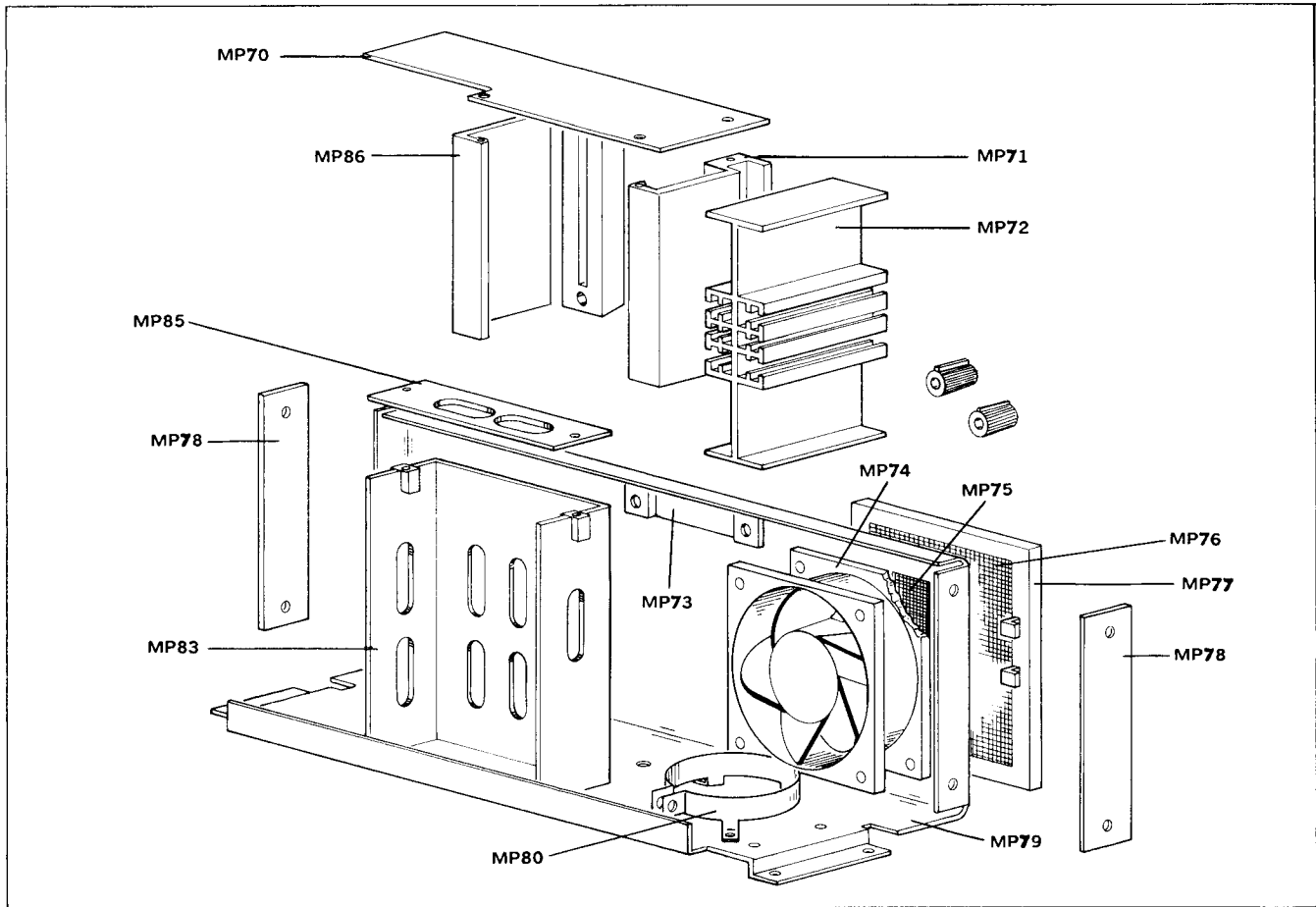

Figure 6-4. Rear Panel Mechanical Parts.

SECTION VII CIRCUIT DIAGRAMS

7-1. INTRODUCTION.

NOTE

7-2. This section of the manual contains troubleshooting information and circuit diagrams for the 3330A/B Automatic Synthesizer. Included are troubleshooting trees, a functional block diagram, schematic diagrams and component location diagrams.

Use the troubleshooting trees in the sequence in which they appear in the manual.

7-3. TROUBLESHOOTING.

7-6. The Symptoms Troubleshooting Table (Table 7-2) can be used to quickly locate known problems.

7-4. The following troubleshooting information is designed to eliminate needless unrelated checks in locating instrument malfunctions. It should first be determined that a malfunction does exist and that it does not exist external to the 3330A/B. Before troubleshooting the 3330A/B, become familiar with the principles of operation (Section III) and the functional composition (Section IV) of the instrument.

7-7. FUNCTIONAL BLOCK DIAGRAM.

7-8. The functional block diagram (Figure 7-5) is simplified and shows the blocks at a board level. It contains waveforms which should prove beneficial in troubleshooting the instrument to a board level. Figure 7-23 is a block diagram of the controller circuits.

7-5. To isolate the malfunction to an assembly, use the Block Diagram (Figure 7-5) and/or the troubleshooting trees (Figures 7-1 through 7-4). To further isolate the malfunction to a component, use the schematic diagrams (Figures 7-6 through 7-34).

7-9. SCHEMATIC DIAGRAMS.

7-10. The schematic diagrams (Figure 7-6 through Figure 7-34) contained in this section show the detailed circuits of the 3330A/B. Components marked with an asterisk are those that are critical in value. The value of these components may vary from one instrument to another. The optimum value is selected at the factory. All options available with the 3330A/B are shown.

REFERENCE DESIGNATIONS

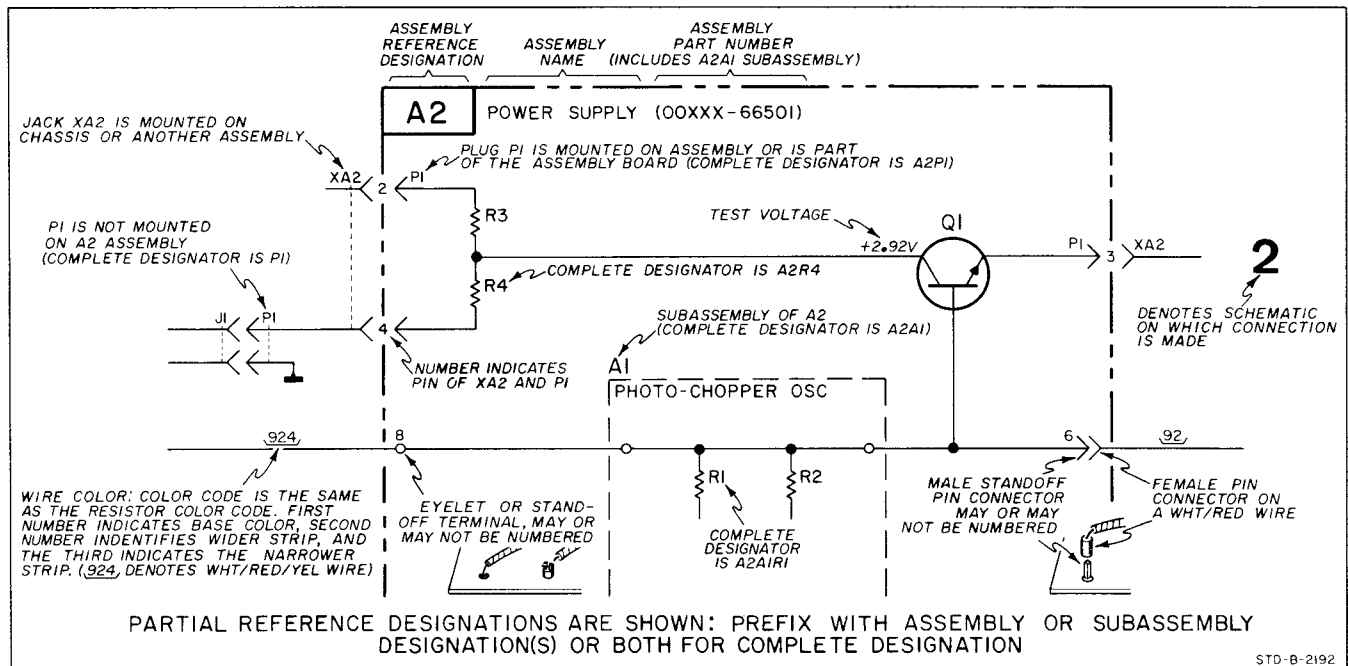

Table 7-1. Assembly Identification and Location.

Assembly	-hp- Part No.	Name	Model	Schematic
A1A	03330-66567	Keyboard	3330A	1
A1B	03330-66501	Keyboard	3330B	1
A2A	03330-66568	Slide Switch	3330A	1
A2B	03330-66502	Slide Switch	3330B	1
A3A	03330-66569	Display	3330A	2
A3B	03330-66503	Display	3330B	2
A4	03330-66504	Mother Board	3330A-3330B	
A5	03330-66505	Digital Output	3330A-3330B	28
A6B	03330-66576	Digital Input	3330B	24
A6B	03330-66577	Digital Input (Option 004)	3330B	25
A6A	03330-66578	Digital Input	3330A	24
A6A	03330-66579	Digital Input (Option 004)	3330A	25
A7	03330-66507	CPU	3330A-3330B	27
A8	03330-66575	Control	3330A-3330B	26
A9	03330-66510	N4 Counter/Sampler	3330A-3330B	5
A10	03330-66509	N4 VTO	3330A-3330B	3
A11	03330-66510	N3 Counter/Sampler	3330A-3330B	5
A12	03330-66511	N3 VTO	3330A-3330B	4
A13	03330-66510	N2 Counter/Sampler	3330A-3330B	5
A14	03330-66511	N2 VTO	3330A-3330B	4
A15	03330-66513	N1 Counter/Sampler	3330A-3330B	7
A16	03330-66512	N1 VTO	3330A-3330B	6
A17	03330-66514	20 MHz VCXO	3330A-3330B	19
A18	03330-66515	Ref Freq Sampler	3330A-3330B	18
A19	03330-66516	Sweep Generator	3330A-3330B	20
A20	03330-66517	SL3 VTO	3330A-3330B	9
A21	03330-66532	SL2 Mixer/Phase Detector	3330A-3330B	8
A22	03330-66517	SL2 VTO	3330A-3330B	9
A23	03330-66533	SL1 Phase Detector	3330A-3330B	10
A24	03330-66520	SL1 Mixer	3330A-3330B	10
A25	03330-66521	SL1 VTO	3330A-3330B	11
A26	03330-66522	Amplitude Reference	3330A-3330B	14
A27	03330-66532	SL3 Mixer/Phase Det.	3330A-3330B	8
A28	03330-66523	Amplitude Detector/Comparator	3330A-3330B	15
A29A	03330-66566	Amplitude Modulator	3330A	16
A29B	03330-66524	Amplitude Modulator	3330B	17
A30	03330-66525	Output Mixer	3330A-3330B	12
A31B	03330-66570	Attenuator 75 Ω (Option 001)	3330B	13
A31B	03330-66526	Attenuator 50 Ω	3330B	13
A32A	03330-66572	Output Amplifier 50 Ω	3330A	13
A32A	03330-66571	Output Amplifier 75 Ω (Option 001)	3330A	13
A32B	03330-66527	Output Amplifier	3330B	13
A32A/B	03330-66564	Output Amplifier 50 Ω (Option 005)	3330A-3330B	22
A33	03330-66528	Reference Oscillator	3330A-3330B	18
A34	03330-66529	Remote Input/Output	3330A-3330B	20
A35	03330-66530	Power Supply	3330A-3330B	21
A35	03330-66561	Power Supply (Option 004)	3330A-3330B	21
A36	03330-66531	Power Supply	3330A-3330B	21
A37	03330-66562	BCD Output (Option H03)	3330A-3330B	Special

Table 7-2. Table of Symptoms.

<p>1. SWEEP OUTPUT does not work properly, but OUTPUT 50 Ω is sweeping when viewed on an oscilloscope</p>	<p>Sweep Generator (A19) is defective.</p>
<p>2. "OUT OF RANGE" does not light when unit goes out of range.</p>	<p>a. Press the following keys: (1) FREQ (3) 5 (2) 1 (4) MHz b. Check XA6B pin J. (1) If XA6B pin J is LOW, check A3CR20 thru A3CR24. (2) If XA6B pin J is HIGH, replace A6.</p>
<p>3. "CTR" does not light when a frequency sweep is in progress and FREQ is pressed:</p>	<p>a. Set : (1) TIME/STEP to 3000 msec. (2) SWEEP to: FREQ BOTH (3) STEPS to 10. b. Press the following keys: (1) FREQ (5) FREQ (8) FIRST (2) 5 STEP POINT (3) . (6) 1 (9) START (4) MHz (7) MHz (10) FREQ c. Connect a logic probe to XA6B pin 11. If pin 11 is HIGH, replace A6. If pin 11 is LOW, check A3CR1.</p>
<p>4. "CTR" does not light when an amplitude sweep is in progress and AMPL is pressed.</p>	<p>a. Set : (1) TIME/STEP to 3000 msec: (2) SWEEP to: AMPL BOTH (3) STEPS to 10 b. Press the following keys: (1) AMPL (5) 1 (8) START (2) 0 (6) + dBm CONT (3) + dBm (7) FIRST (9) AMPL POINT (4) AMPL STEP c. Connect A Logic Probe to XA6B pin M. Pin M should be low. If pin M is HIGH, replace A6. If pin M is LOW, check A3CR25.</p>
<p>5. "MIN" does not light at the end of a frequency sweep.</p>	<p>a. Set: (1) TIME/STEP to 3000 msec: (2) SWEEP to: FREQ UP (3) STEPS to 10. b. Press the following keys: (1) FREQ (4) FREQ (6) MHz (2) 5 STEP (7) FIRST (3) MHz (5) 1 POINT c. Check XA6B pin 15. If pin 15 is HIGH, replace A6. If pin 15 is LOW, check A3CR2.</p>
<p>6. "MAX" does not light at the end of a frequency sweep.</p>	<p>a. Set: (1) TIME/STEP to 3000 msec. (2) SWEEP to: FREQ DOWN (3) STEPS to 10. b. Press the following keys:</p>

(Continued)

Table 7-2. Table of Symptoms (Cont'd).

		(1) FREQ (2) 5 (3) MHz	(4) FREQ STEP (5) 1	(6) MHz (7) FIRST POINT	c. Check XA6B pin 16. If pin 16 is HIGH, replace A6. If pin 16 is LOW, check A3CR3.
7. "MIN" does not light at the end of an amplitude sweep.					a. Set: (1) TIME/STEP to 3000 msec. (2) SWEEP to: AMPL UP (3) STEPS to 10. b. Press the following keys: (1) AMPL (4) AMPL (6) + dBm (2) 0 STEP (7) FIRST (3) + dBm (5) 1 POINT c. Connect Logic Probe to XA6B pin T. If pin T is HIGH, replace A6. If pin T is LOW, check A3CR26.
8. "MAX" does not light at the end of an amplitude sweep.					a. Set: (1) TIME/STEP to 3000 msec. (2) SWEEP to: AMPL DOWN (3) STEPS to 10 b. Press the following keys: (1) AMPL (4) AMPL (6) + dBm (2) 0 STEP (7) FIRST (3) + dBm (5) 1 POINT c. Check XA6B pin U. If pin U is HIGH, replace A6. If pin U is LOW, check A3CR27.
9. "STEP" does not light when is pressed. Display shows a new frequency step when entered.	FREQ STEP				a. Press: FREQ STEP b. Check XA6B pin 10. If pin 10 is HIGH, replace A6. If pin 10 is LOW, check A3CR8 and A3CR9.
10. "STEP" does not light when is pressed. Display shows a new amplitude step when entered.	AMPL STEP				a. Press: AMPL STEP b. Check XA6B pin S. If pin S is HIGH, replace A6. If pin S is LOW, A3CR28 and A3CR29.
11. Output frequency is correct but display is incorrect.					One or more numeric digits are probably defective. Try exchanging the digit with one that is displaying the correct number. If the problem is transferred to the new position, replace the defective numeric digit. If the problem is not transferred, check the W5 cable.
12. Output amplitude is correct but display is incorrect.					One or more numeric digits are probably defective. Try exchanging the digit with one that is displaying the correct number. If the problem is transferred to the new position, replace the defective digit. If the problem is not transferred, check the W5 cable.
13. Sweep functions do not work properly. For example: a. When the mode switch is changed from AMPL to FREQ, the unit continues to sweep amplitude. b. When the mode switch is changed from FREQ to AMPL, the unit continues to sweep frequency. c. Sweep direction (UP, BOTH, DOWN) and STEPS appear to have no effect. TIME/STEP appears to have no effect when changed.					Check the following in order: 1. Check all front panel slide switches to see that they are securely in their detents. 2. Check to see that the cable is securely fastened to the SLIDE SW Connector on the Mother Board. 3. Go to Step 7 of the Controller Troubleshooting.
14. 3330A/B will operate satisfactorily from the front panel but WILL NOT operate properly when programmed remotely.					1. Check the programming source to see that it is working properly. 2. Replace A6. Could also be A7 or A8.

REFERENCE FREQUENCY NOTES

p/o Figure 7-1

- 1,2. This check insures that the 100 kHz Reference Signal is being supplied to each of the N-loops. be performed, but is only necessary when the 100 kHz reference is incorrect for all the N-loops.)
3. This check insures that the 1 MHz signal is correct. If this 1 MHz signal is correct, then the 2 MHz signal for the Amplitude Reference (A26) and the digital controller is correct.
5. The 20 MHz Oscillator is working properly, yet the 100 kHz signal is not correct. Therefore, the problem must be in the dividing circuitry on the A17 assembly.
4. The purpose of this check is to determine if the 20 MHz VCXO is working. (This check should always
- 9,10. The purpose of this check is to verify that the 20 MHz oscillator can be tuned by a dc voltage.

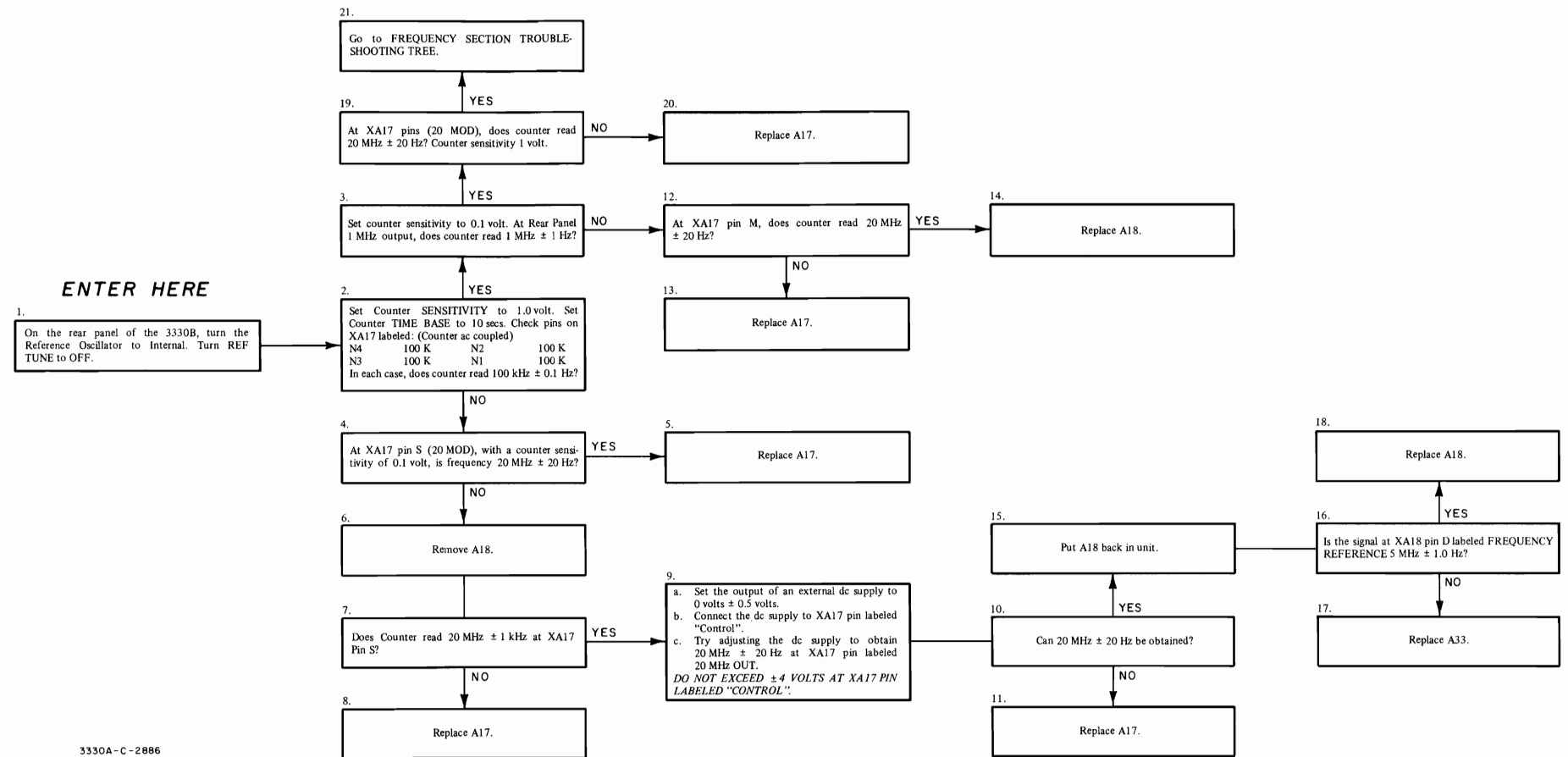

3330A-C-2886

NOTE

The number in the upper left-hand corner of each box on the troubleshooting tree corresponds to the number in the troubleshooting tree notes. These notes contain additional information concerning the procedure to be performed.

Figure 7-1. Reference Frequency Troubleshooting Tree.

INSTRUCTIONS FOR CONTROLLER TROUBLESHOOTING

p/o Figure 7-2

The 3330A/B Digital Controller is a small Digital Computer. A very simple action on the part of an operator (such as pressing a key on the front panel) will initiate a number of sequential operations inside the Controller. Such operations are not characterized by repetitive waveforms, stable logic states or any other characteristics which are normally the basis for conventional troubleshooting techniques. For this reason, such techniques are not effective for troubleshooting the Controller.

Before performing the troubleshooting procedures on this page, check the Table of Symptoms, Table 7-2. This gives possible solutions based on a number of visible symptoms.

Two possible methods of Controller troubleshooting are presented here. To repair the Controller in a minimum amount of time, the board substitution method of troubleshooting is recommended, because of the complexity of the circuits and the resultant difficulty of troubleshooting to component level. This method requires a replacement set of Controller assemblies (A5, A6, A7, and A8). Use the following procedure to isolate the problem.

1. Perform the checks outlined in the Reference Frequency Troubleshooting Tree, Figure 7-1. This will verify that the 2 MHz clock is working.
2. Perform Step 1 of the Controller Troubleshooting Tree.
3. If the instrument does not start up properly,
 - a. Proceed in the Controller Troubleshooting Tree as far as Step 3. This step checks to see if the start-up pulse is being applied to the Controller.
 - b. If the start-up pulse is not being applied to the Controller, replace A19 as indicated in Step 4.
 - c. If the start-up pulse is being applied to the Controller, determine which Controller assembly is defective by substituting Controller boards.
 - d. Order a replacement assembly and return the defective assembly to your nearest -hp- Sales and Service Office.
4. If the unit does start up properly, continue through the troubleshooting trees.
 - a. If a tree indicates a return to Controller troubleshooting, try substituting Controller boards to locate the defective assembly.
 - b. Order a replacement assembly and return the defective assembly to your nearest -hp- Sales and Service Office.

In the event that troubleshooting by the board substitution method is not possible or practical in a given situation, the following method is suggested. This method requires the use of a logic state analyzer in conjunction with the Controller flowcharts. The flowchart on this page is the normal 3330A/B start-up routine, which exercises approximately 80% of the Controller circuits. Complete flowcharts are given in Figures 7-35 through 7-39. A block diagram and schematic diagrams for all the Controller assemblies are shown in Figures 7-29 through 7-34.

1. Perform the checks outlined in the Reference Frequency Troubleshooting Tree, Figure 7-1. This will verify that the 2 MHz clock is working.
2. Connect the data inputs of a logic state analyzer, such as the -hp- Model 1601A, to the ROM address bits as shown in the diagram of A8 Test Jack F, shown at right. An adapter, such as Cambion Part No. 702-3728-01-03-00 (16-pin), and an IC clip, such as Pomona Electric DIP Clip, Part No. 3916, are very useful in making these connections. If an IC DIP Clip but no adapter is available, this may be clipped to one of the ROM IC's. Refer to the Control Assembly schematic diagram, Figure 7-32, for the proper connections. The Control Assembly, A8, must be mounted on extender boards to make these connections. Assembly locations are shown in Figure 5-8, and component locations are shown on the schematic diagrams.
3. Connect the logic state analyzer clock input to the Control Clock signal at pin 14 of Test Jack C on the CPU Assembly, A7. A 14-pin adapter that can be used in this test jack is Cambion Part No. 702-3725-01-03-00. The Control Clock (CC) signal is also available at A7U6 pin 3, A8U14 pin 9, or A8U16 pin 9.
4. Set the logic state analyzer Trigger Word switches to ROM state address 200 as follows:

8 and above	7	6	5	4	3	2	1	0
OFF	HI	LO	LO	LO	LO	LO	LO	LO
5. Set other logic state analyzer controls as follows:

LOGIC	POS
CLOCK	POS
THRESHOLD	TTL
SAMPLE MODE	SINGLE
TRIGGER MODE	START DISPLAY
DELAY SET switches	ZERO

Adjust COLUMN BLANKING to display eight columns.
6. Turn 3330A/B power switch to STDBY. Press logic state analyzer RESET button, then turn 3330A/B on.

7. Compare the analyzer display sequence to the ROM state addresses shown on the Start-Up Routine flowchart. If all 16 states are correct, set the DELAY SET switches to 16, turn 3330A/B power to STDBY, press analyzer RESET, and turn 3330A/B on. Analyzer display should continue to follow the flowchart. The numbers at the left side of the rectangular blocks on the flowchart are the decimal sequence in which the analyzer should read the states.

If, at the first turn-on, the analyzer display remains blank, check the clock connection and/or reverse the position of

the clock polarity switch.

If the display is all zeros, check the level of the start-up pulse at XA8B pin E. The level should be a TTL low. If not, the trouble may be on the Sweep Generator Assembly, A19.

8. Proceed through the flowchart in the above manner. If, at any point, the sequence of states deviates from the flowchart, the complete flowcharts, Figures 7-35 through 7-39 may be used to help determine the cause.

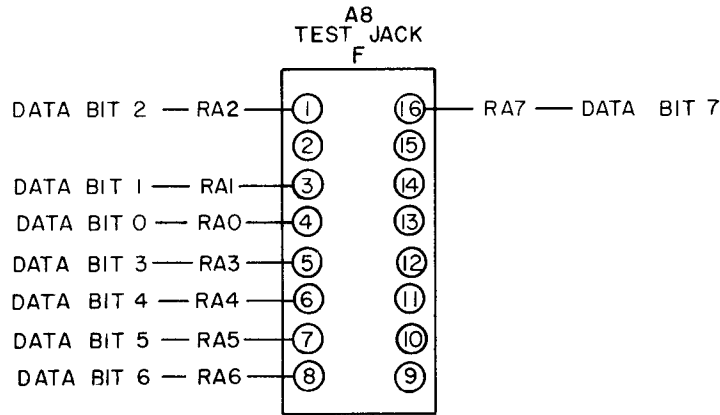

CONTROLLER TROUBLESHOOTING TREE

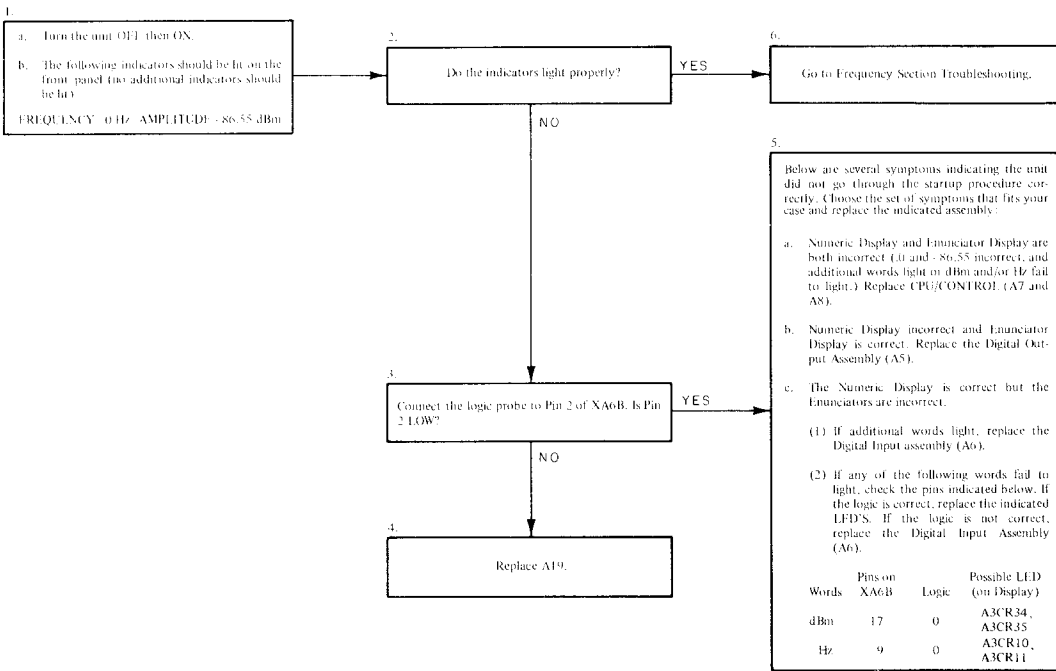

7. Disconnect KEYBOARD and SLIDE SW at connectors on front of the Motherboard.
8. Try to program with a card reader the same Frequency or Amplitude which failed in previous tree.
9. The following is a list of possible results. Choose one (a or b) that best fits your observations.
 - a. Instrument will program neither remotely nor from the front panel.

Solution:

 - (1) First, try replacing the Digital Input Assembly (A6).
 - (2) If (1) does not solve the problem, try replacing the CPU/Control Assembly (A7 and A8).
 - b. Instrument operates properly when programmed from the rear panel.
 - (1) Perform Controller-Keybaord Isolation Checks.
 - (2) If the Controller-Keybaord Isolation checks indicate the problem is in the Controller, replace the Digital Input assembly (A6).

Words	Pins on XA6B	Logic	Possible LED (on Display)
dBm	17	0	A3CR34, A3CR35
Hz	9	0	A3CR10, A3CR11

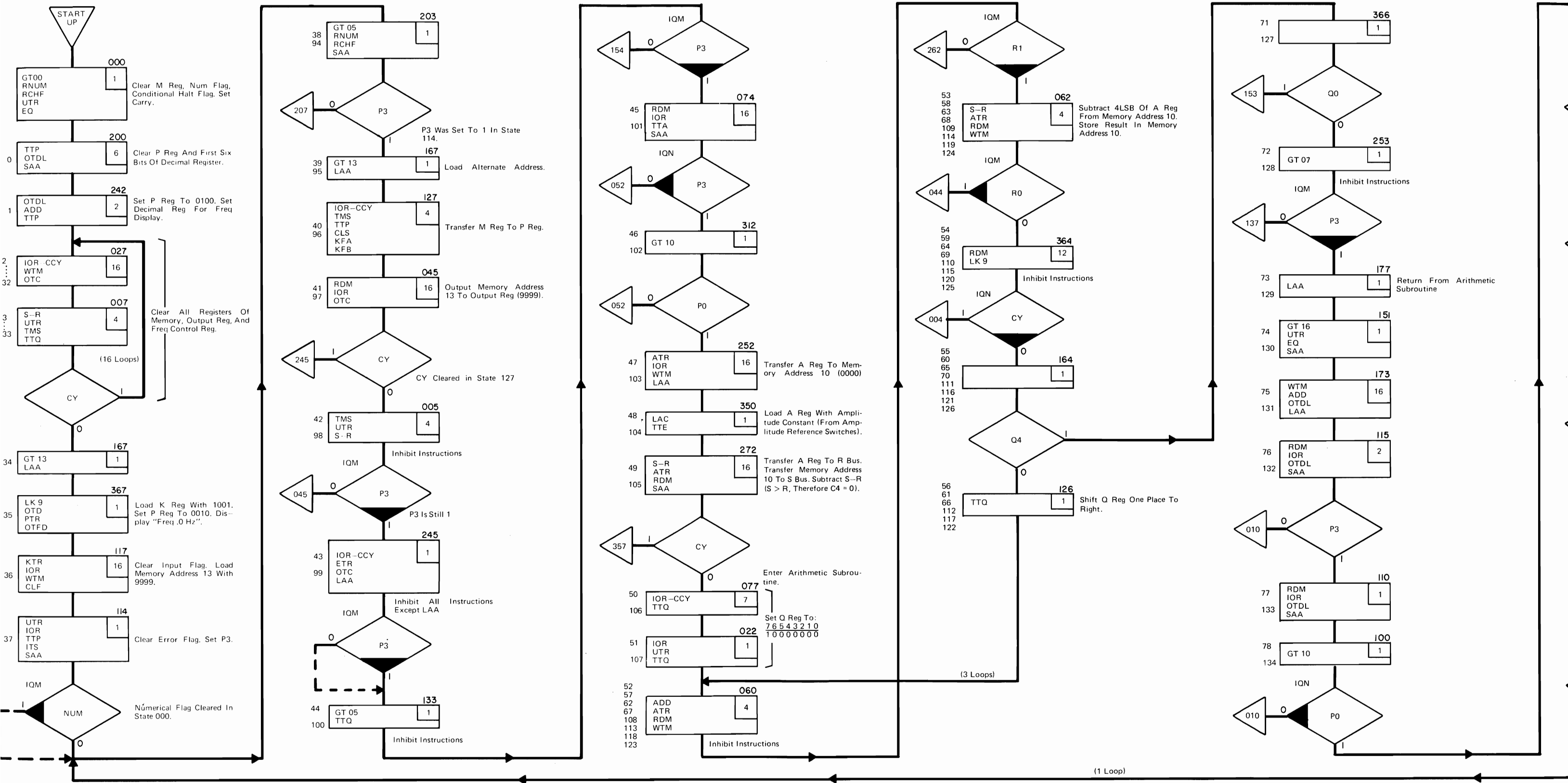

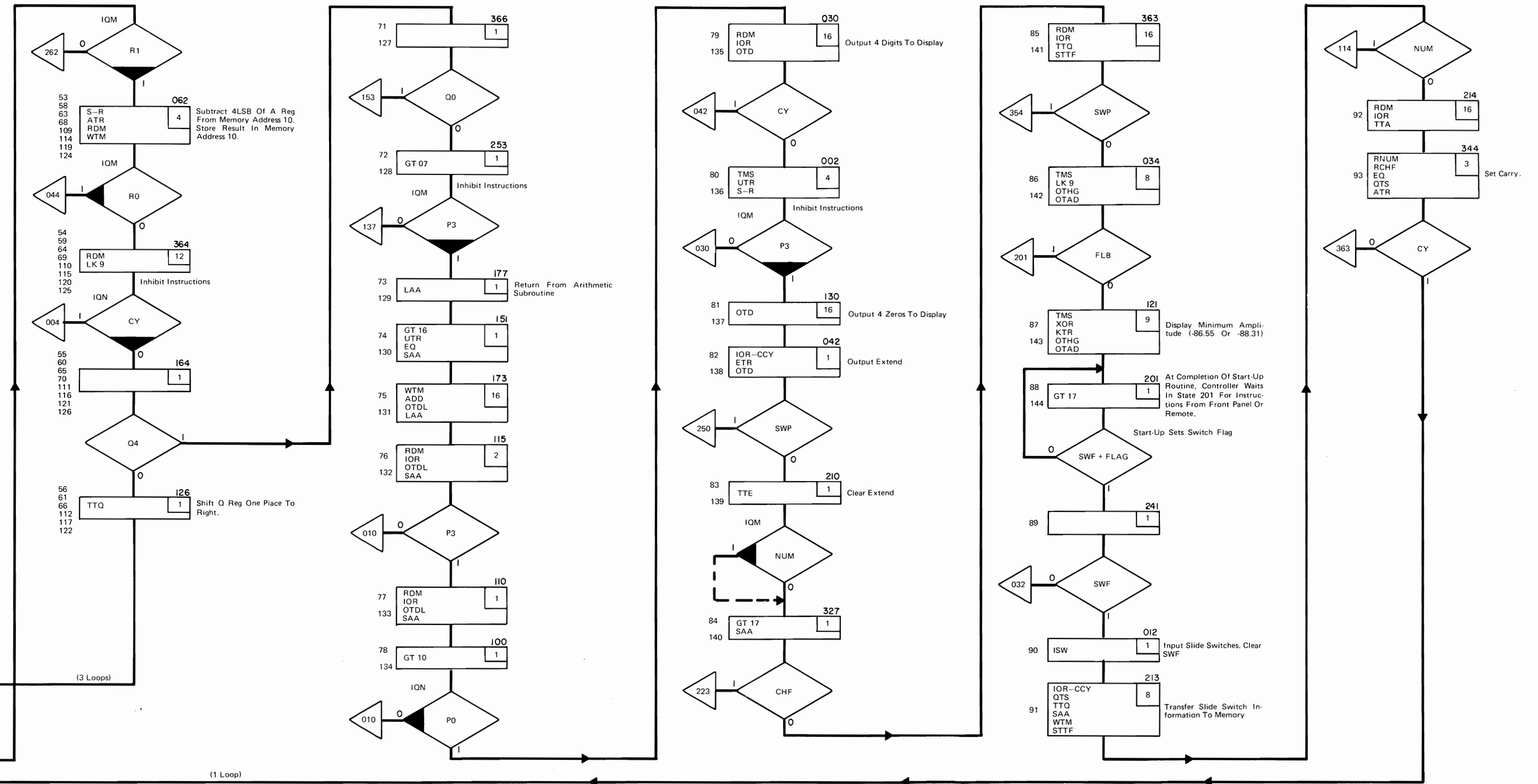

Figure 7-2. Controller Troubleshooting.

FREQUENCY GENERATING NOTES

p/o Figure 7-3

- 1,2. Setting the instrument to the frequencies 12777777.7 Hz, 8888888.8 Hz and 5000000.0 Hz checks the ability of the $\div N$ loops to respond to different bit patterns. These frequencies also check the display and output register of the Controller.
4. The purpose of this check is to see if the display is working properly.
5. See Note 1, 2.
7. See Note 4.
8. See Note 1, 2.
10. See Note 4.
12. The output is correct; yet the display is not correct. Therefore, there is a problem in the display.
13. See Note 12.
14. See Note 12.
- 15,16. The output frequency is wrong. However, it is possible that the display could still be correct. If the display is correct, this means that the keyboard is functioning properly. If the display is not correct, there is a possibility that the keyboard is malfunctioning.
- 17,18. See Note 15, 16.
- 19,20. See Note 15, 16.
- 21,22. The purpose of this check is to see if the problem is in the Frequency or the Amplitude Section.
- 23,24. See Note 21, 22.
- 25,26. The purpose of this check is to determine if the N-loops are functioning properly.
- 30,31. This test assumes that, if the VTO is oscillating at approximately the correct frequency, then the problem must be in the VMC.
- 32,33. The N4 loop is working properly. However, the N3 loop is not. Since the N4 VMC and the N3 VMC are identical except for the position of S1, interchange these boards and see if the problem is solved.
43. Here the frequency is set to 0 Hz; then later in Step 67 it is set to 9.9999999 MHz. The purpose of this is to force the SL loops to operate at both ends of their range.
44. a. At SL3RF on A20 is frequency 20 MHz \pm 100 Hz? If no, go to Step 59. If yes, go to part b of this note.
 - b. Use the following procedure to determine if the frequency at SL2REF on A20 is equal to the frequency at SL3RF divided by 10.
 - (1) Connect a $\div 10$ probe to each channel of an oscilloscope.
 - (2) Connect Channel A to SL3RF on 3330 Mother Board.
 - (3) Connect Channel B to SL2REF on 3330 Mother Board.
 - (4) Is the frequency of the signal on Channel A equal to 10 times the frequency of the signal on Channel B, as shown in Figure 1. If yes, go to Step 63. If no, go to Step 59.
60. a. Can frequency at SL3RF on A20 be set to 20.00 MHz to 20.001 MHz using the following procedure?
 - (1) Set an adjustable dc supply to +1 vdc.
 - (2) Connect the supply to SL3 ERR on A20.
 - (3) Monitor the frequency at SL3 RF on A20 with a counter.
 - (4) Carefully adjust the dc supply through a range of 0 to +4 volts until the counter reads 20.0 MHz to 20.001 MHz.

If the counter does not read in the above range, go to Step 62.

If the counter does read in this range, go to part b of this note.

 - b. Use the following procedure to determine if the frequency at SL2REF on A20 is equal to the frequency at SL3RF divided by 10.
 - (1) Connect a $\div 10$ probe to each channel of an oscilloscope.
 - (2) Connect Channel A to SL3RF on 3330 Mother Board.
 - (3) Connect Channel B to SL2REF on 3330 Mother Board.
 - (4) Is the frequency of the signal on Channel A equal to 10 times the frequency of the signal on Channel B, as shown in Figure 1. If yes, go to Step 61. If no, go to Step 62.

FREQUENCY GENERATING NOTES (Cont'd)

p/o Figure 7-3

63. a. At SL2RF on A22 is frequency 20 MHz \pm 1 Hz? If no, go to Step 64. If yes, go to part b of this note. signal on Channel B, as shown in Figure 1. If yes, go to Step 66. If no, go to Step 67.
- b. Use the following procedure to determine if the frequency at SL1REF on A22 is equal to the frequency at SL2RF divided by 10.
- (1) Connect a \div 10 probe to each channel of an oscilloscope.
 - (2) Connect Channel A to SL2RF on 3330 Mother Board.
 - (3) Connect Channel B to SL1REF on 3330 Mother Board.
 - (4) Is the frequency of the signal on Channel A equal to 10 times the frequency of the signal on Channel B, as shown in Figure 1? If yes, go to Step 68. If no, go to Step 64.
65. a. Can frequency at SL2RF on A22 be set to 20.0 MHz to 20.001 MHz using the following procedure?
- (1) Set an adjustable dc supply to + 1 vdc.
 - (2) Connect the supply to SL2 ERR on A22.
 - (3) Monitor the frequency at SL2 RF on A22 with a counter.
 - (4) Carefully adjust the dc supply through a range of 0 to + 4 volts until the counter reads 20.0 MHz to 20.001 MHz.
- If the counter does not read in the above range, go to Step 67.
- If the counter does read in this range, go to part b of this note.
- b. Use the following procedure to determine if the frequency at SL1REF on A22 is equal to the frequency at SL2 RF divided by 10.
- (1) Connect a \div 10 probe to each channel of an oscilloscope.
 - (2) Connect Channel A to SL2RF on 3330 Mother Board.
 - (3) Connect Channel B to SL1REF on 3330 Mother Board.
 - (4) Is the frequency of the signal on Channel A equal to 10 times the frequency of the
69. a. At SL3RF on A20 is frequency 29.999 MHz \pm 100 Hz? If no, go to Step 70. If yes, go to part b of this note.
- b. Use the following procedure to determine if the frequency at SL2REF on A20 is equal to the frequency at SL3RF divided by 10.
- (1) Connect a \div 10 probe to each channel of an oscilloscope.
 - (2) Connect Channel A to SL3RF on 3330 Mother Board.
 - (3) Connect Channel B to SL2REF on 3330 Mother Board.
 - (4) Is the frequency of the signal on Channel A equal to 10 times the frequency of the signal on Channel B, as shown in Figure 1. If yes, go to Step 74. If no, go to Step 70.
71. a. Can frequency at SL3RF on A20 be set to 29.999 MHz to 30.000 MHz using the following procedure?
- (1) Set an adjustable dc supply to + 1 vdc.
 - (2) Connect the supply to SL3ERR on A20.
 - (3) Monitor the frequency at SL3RF on A20 with a counter.
 - (4) Carefully adjust the dc supply through a range of 0 to + 4 volts until the counter reads 29.999 MHz to 30.0 MHz.
- If the counter does not read in the above range, go to Step 73.
- If the counter does read in this range, go to part b of this note.
- b. Use the following procedure to determine if the frequency at SL2REF on A20 is equal to the frequency at SL3RF divided by 10.
- (1) Connect a \div 10 probe to each channel of an oscilloscope.
 - (2) Connect Channel A to SL3RF on 3330 Mother Board.

FREQUENCY GENERATING NOTES (Cont'd)

p/o Figure 7-3

- (3) Connect Channel B to SL2REF on 3330 Mother Board.
- (4) Is the frequency of the signal on Channel A equal to 10 times the frequency of the signal on Channel B, as shown in Figure 1. If yes, go to Step 72. If no, go to Step 73.
74. a. At SL2RF on A22 is frequency 29.999990 MHz \pm 1 Hz? If no, go to Step 75. If yes, go to part b of this note.
- b. Use the following procedure to determine if the frequency at SL1REF on A22 is equal to the frequency at SL2RF divided by 10.
- (1) Connect a \div 10 probe to each channel of an oscilloscope.
 - (2) Connect Channel A to SL2RF on 3330 Mother Board.
 - (3) Connect Channel B to SL1 REF on 3330 Mother Board.
 - (4) Is the frequency of the signal on Channel A equal to 10 times the frequency of the signal on Channel B, as shown in Figure 1. If yes, go to Step 79. If no, go to Step 75.
76. a. Can frequency at SL2RF on A22 be set to 29.99999 MHz to 30.00099 MHz using the following procedure?
- (1) Set an adjustable dc supply to + 1 vdc.
 - (2) Connect the supply to SL2ERR on A22.
 - (3) Monitor the frequency at SL2RF on A22 with a counter.
 - (4) Carefully adjust the dc supply through a range of 0 to + 4 volts until the counter reads 29.99999 MHz to 30.00099 MHz.
- If the counter does not read in the above range, go to Step 78.
- If the counter does read in this range, go to part b of this note.
- b. Use the following procedure to determine if the frequency at SL1REF on A22 is equal to the frequency at SL2RF divided by 10.
- (1) Connect a \div 10 probe to each channel of an oscilloscope.
- (2) Connect Channel A to SL2RF on 3330 Mother Board.
- (3) Connect Channel B to SL1REF on 3330 Mother Board.
- (4) Is the frequency of the signal on Channel A equal to 10 times the frequency of the signal on Channel B, as shown in Figure 1. If yes, go to Step 77. If no, go to Step 78.
80. Can the frequency at RF + 20 MHz and "20 MHz MIX" on XA25 be set to 29.9999999 MHz to 30.0009999 MHz using the following procedure.
- a. Set an adjustable dc supply to + 1 volt.
 - b. Connect the supply to SL1ERR on XA25.
 - c. Monitor the frequency at SL1RF on XA25 with a counter.
 - d. Carefully adjust the dc supply through a range of 0 to + 4 volts until the counter reads 29.9999999 to 30.0009999 MHz.
- If the instrument passes this check, go to Step 82. If the instrument fails this check, go to Step 81.
83. Can the frequency at RF + 20 MHz and "20 MHz MIX" on XA25 be set to 20.000 MHz to 20.0001 MHz using the following procedure:
- a. Set an adjustable dc supply to + 1 volt.
 - b. Connect the supply to SL1ERR on XA25.
 - c. Monitor the frequency at SL1RF on XA25 with a counter.
 - d. Carefully adjust the dc supply through a range of 0 to + 4 volts until the counter reads 20.000 to 20.0001 MHz.
- If the instrument passes this check, go to Step 85. If the instrument fails this check, go to Step 84.
86. a. Set frequency on front panel to 9.9999999 MHz.
- b. Using the procedure outlined in Note 80, set the frequency at SL1RF on XA25 to 29.9999999 MHz to 30.0009999 MHz. Record the frequency at SL1RF.
- c. At XA24 Pin S does the frequency = frequency at SL1RF - 29.7 MHz?

FREQUENCY GENERATING NOTES (Cont'd)

p/o Figure 7-3

90. All the N-loops have failed. In order to troubleshoot the unit, remove A9, A11, A13 and A15. Use the following procedure for checking A10, A12, A14, and A16.

a. Procedure for checking A10.

- (1) Set front panel to 12.7777777 MHz.
- (2) Set the output of an external power supply to +1 volt.
- (3) Connect the output of the supply to N4ERR on XA10.
- (4) Connect the counter to N4RF on XA10. By slowly adjusting the output of the dc supply from 0 to +4 volts, attempt to set the frequency at N4RF to 27.7 MHz ± 0.1 MHz. If it is not possible to set the frequency at N4RF to within ± 100 kHz of the correct frequency, replace A10. If it is possible to set the frequency at N4RF to within ± 100 kHz of the correct frequency, perform Steps 1 thru 4 for 8.8888888 MHz and 5.0000000 MHz. Then go to Step 5.

Front Panel Frequency Setting	Frequency at N4RF
8.8888888 MHz	28.8 MHz ± 100 kHz
5.0000000 MHz	20.0 MHz ± 100 kHz

(5) If the unit passes checks 1 thru 4, replace A9.

b. Procedure for checking A12:

- (1) Set front panel to 12.7777777 MHz.
- (2) Set the output of an external power supply to +1 volt.
- (3) Connect the output of the supply to N3ERR on XA12.
- (4) Connect the counter to N3RF on XA12. By slowly adjusting the output of the dc supply from 0 to +4 volts, attempt to set the frequency at N3RF to 27.5 MHz ± 0.1 MHz. If it is not possible to set the frequency at N3RF to within ± 100 kHz of the correct frequency, replace A12. If it is possible to set the frequency at N3RF to within ± 100 kHz of the correct frequency, perform Steps 1 thru 4 for 8.8888888 MHz and 5.0000000 MHz. Then go to Step 5.

Front Panel Frequency Setting	Frequency at N3RF
8.8888888 MHz	28.6 MHz ± 100 kHz
5.0000000 MHz	19.8 MHz ± 100 kHz

(5) If the unit passes checks 1 thru 4, replace A11.

c. Procedure for checking A14.

- (1) Set front panel to 12.7777777 MHz.
- (2) Set the output of an external power supply to +1 volt.
- (3) Connect the output of the supply to N2ERR on XA14.
- (4) Connect the counter to N2RF on XA14. By slowly adjusting the output of the dc supply from 0 to +4 volts, attempt to set the frequency at N2RF to 27.5 MHz ± 0.1 MHz. If it is not possible to set the frequency at N2RF to within ± 100 kHz of the correct frequency, replace A14. If it is possible to set the frequency at N2RF to within ± 100 kHz of the correct frequency, perform Steps 1 thru 4 for 8.8888888 MHz and 5.0000000 MHz. Then go to Step 5.

Front Panel Frequency Setting	Frequency at N2RF
8.8888888 MHz	28.6 MHz ± 100 kHz
5.0000000 MHz	19.8 MHz ± 100 kHz

(5) If the unit passes checks 1 thru 4, replace A13.

d. Procedure for checking A16.

- (1) Set front panel to 12.7777777 MHz.
- (2) Set the output of an external power supply to +1 volt.
- (3) Connect the output of the supply to N1ERR on XA16.
- (4) Connect the counter to N1RF on XA16. By slowly adjusting the output of the dc supply from 0 to +4 volts, attempt to set the frequency at N1RF to 32.5 MHz ± 0.1 MHz. If it is not possible to set the frequency at N1RF to within ± 100 kHz of the correct frequency, replace A16. If it is possible to set the frequency at N1RF to within ± 100 kHz of the correct frequency, perform Steps 1 thru 4 for 8.8888888 MHz and 5.0000000 MHz. Then go to Step 5.

Front Panel Frequency Setting	Frequency at N1RF
8.8888888 MHz	28.6 MHz ± 100 kHz
5.0000000 MHz	19.8 MHz ± 100 kHz

(5) If the unit passes checks 1 thru 4, replace A15.

Table 1. Test for N Loop Outputs.

Instructions:

1. Pin names are located at the assembly number on the Mother Board.
2. Note which assemblies fail and at which frequency.
3. Perform test with Counter to 0.1 V sensitivity and 0.1 sec Time Base. All frequencies should be accurate to ± 1 count on the counter display.
4. Use 11002A Test Leads (split pair) to make all frequency measurements.

Board Name	Assembly Number	Frequency Programmed (Hz)	Pin Name (1)	Frequency at Pin Name(1)(MHz)	Pin Name (2)	Frequency at Pin Name(2)(MHz)
N4 VTO	A10	12 777 777.7	N4RF	27.7	SL3REF	2.77
		8 888 888.8	N4RF	28.8	SL3REF	2.88
		5 000 000.0	N4RF	20.0	SL3REF	2.00
N3 VTO	A12	12 777 777.7	N3RF	27.5	N3SL3RF	27.5
		8 888 888.8	N3RF	28.6	N3SL3RF	28.6
		5 000 000.0	N3RF	19.8	N3SL3RF	19.8
N2 VTO	A14	12 777 777.7	N2RF	27.5	NLSL2RF	27.5
		8 888 888.8	N2RF	28.6	N2SL2RF	28.6
		5 000 000.0	N2RF	19.8	N2SL2RF	19.8
N1 VTO	A16	12 777 777.7	N1RF	32.5	N1SL1RF	32.5
		8 888 888.8	N1RF	28.6	N1SL1RF	28.6
		5 000 000.0	N1RF	24.8	N1SL1RF	24.8

Table 4. Logic for N2 Loop.

Frequency (MHz)	The Points Below are Labeled on A13 on Mother Board							
	F800K	F400K	F200K	F100K	F80K	F40K	F20K	F10K
12.777 777 7	0	1	1	1	0	1	1	1
8.888 888 8	1	0	0	0	1	0	0	0
5.000 000 0	0	0	0	0	0	0	0	0

Table 2. Test for N1 Loop VTO.

Board Name	Assembly Number	Pin Name	Frequency Programmed	Frequency at Pin (± 0.3 MHz)
N1 VTO	A16	N1RF	12.777 777 7 MHz	32.5 MHz
			8.888 888 8 MHz	28.6 MHz
			5.000 000 0 MHz	24.8 MHz

If the frequency at Pin (N1RF) is not within the limits given, try adjusting A16R11. If the desired frequency is not obtainable by adjusting A16R11, the N1 VTO fails this test.

Table 5. Logic for N3 Loop.

Frequency (MHz)	The Points Below are Labeled on A11 on Mother Board							
	F8K	F4K	F2K	F1K	F800	F400	F200	F100
12.777 777 7	0	1	1	1	0	1	1	1
8.888 888 8	1	0	0	0	1	0	0	0
5.000 000 0	0	0	0	0	0	0	0	0

Table 3. Logic for N1 Loop.

Frequency (MHz)	The Points Below are Labeled on XA15 on Mother Board								
	F100M	F80M	F40M	F20M	F10M	F8M	F4M	F2M	F1M
12.777 777 7	1	0	0	1	0	0	1	1	1
8.888 888 8	0	1	0	0	0	1	0	0	0
5.000 000 0	0	0	1	0	1	0	1	0	1

Table 6. Logic for N4 Loop.

Frequency (MHz)	The Points Below are Labeled on A9 on Mother Board							
	F80	F40	F20	F10	F8	F4	F2	F1
12.777 777 7	0	1	1	1	0	1	1	1
8.888 888 8	1	0	0	0	1	0	0	0
5.000 000 0	0	0	0	0	0	0	0	0

ENTER HERE
NOTE
The number in the upper left-hand corner of each box on the troubleshooting tree corresponds to the number in the troubleshooting tree notes. These notes contain additional information concerning the procedure to be performed.

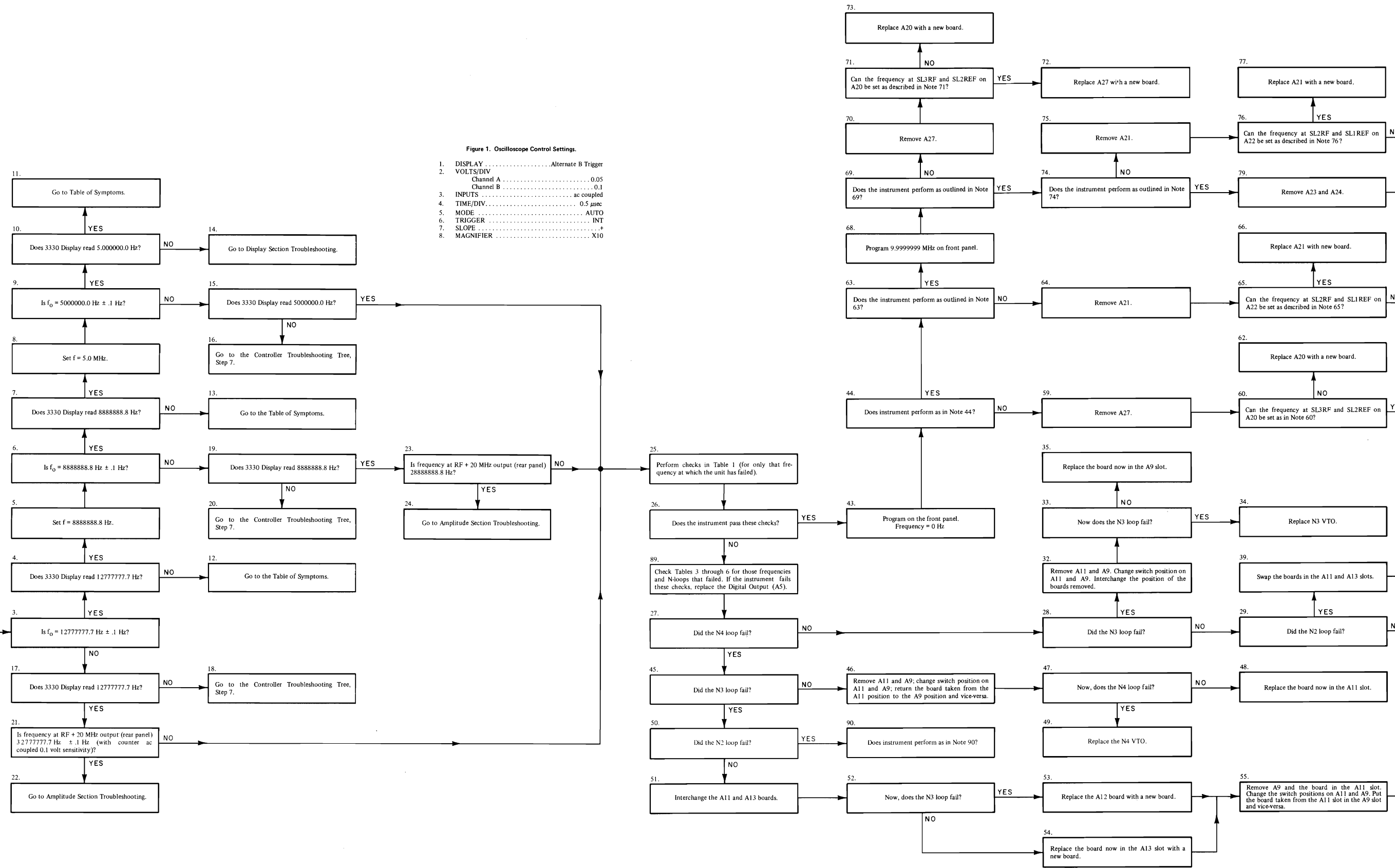

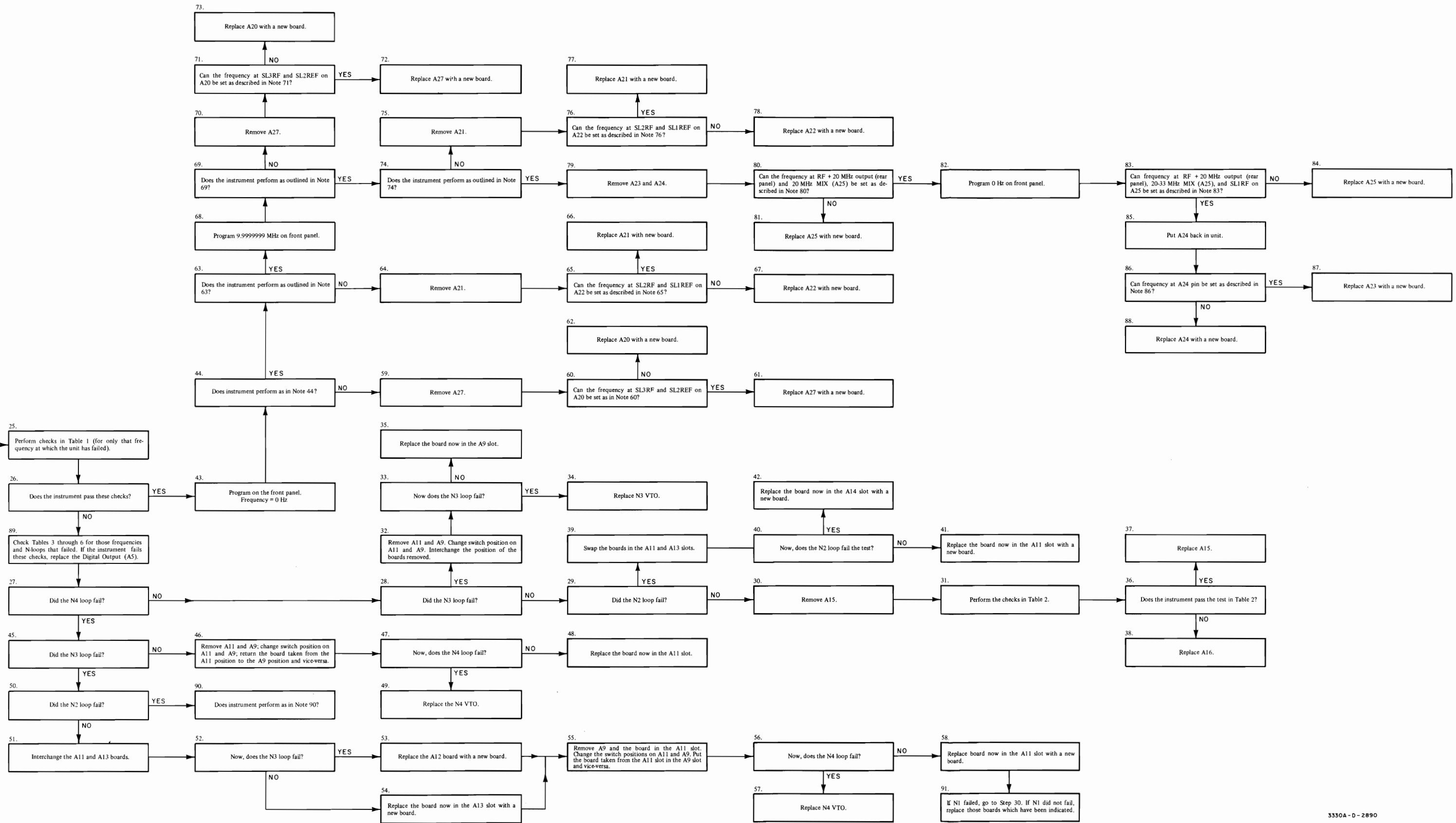

3330A-D-2890

NOTE

The number in the upper left-hand corner of each box on the troubleshooting tree corresponds to the number in the troubleshooting tree notes. These notes contain additional information concerning the procedure to be performed.

Figure 7-3. Frequency Generating Troubleshooting Tree.

SL1 PHASE DETECTOR

The following procedure may be used for verification and troubleshooting of the SL1 Phase Detector. The procedure forces the Phase Detector into certain operating conditions and checks for the appropriate outputs. Assembly location is shown in Figure 5-8.

- a. Disconnect ac power from the instrument.
- b. Remove A9, N4 Counter/Sampler, from the instrument and move the slide switch A9S1 off the N4 position. Replace A9.
- c. Remove A25, SL1 VTO, from the instrument.
- d. Near the left rear of the instrument, disconnect the red cable from the 1 MHz jack and connect it to the 20 MHz jack. This places a 20 MHz signal on the rear panel 1 MHz OUT connector.

e. Connect a BNC-to-split-pair cable to the rear panel 1 MHz OUT connector. Connect the ground side of the split pair to the 3330A/B chassis, and connect the high side to A24TP2 (see component locator drawing of Schematic No. 10).

f. Mount A23, SL1 Phase Detector, on a printed circuit extender.

g. Connect ac power to the instrument and turn front panel switch to ON.

h. Set front panel controls as follows:

FREQ 0.2 Hz
 FREQ STEP 0.1 Hz
 TIME/STEP 3000 ms

i. Connect Channel A of a dual channel oscilloscope to A23TP3, and connect Channel B to A23TP6. Internally trigger oscilloscope on Channel B. The following waveforms should be present (each 200 kHz, TTL levels):

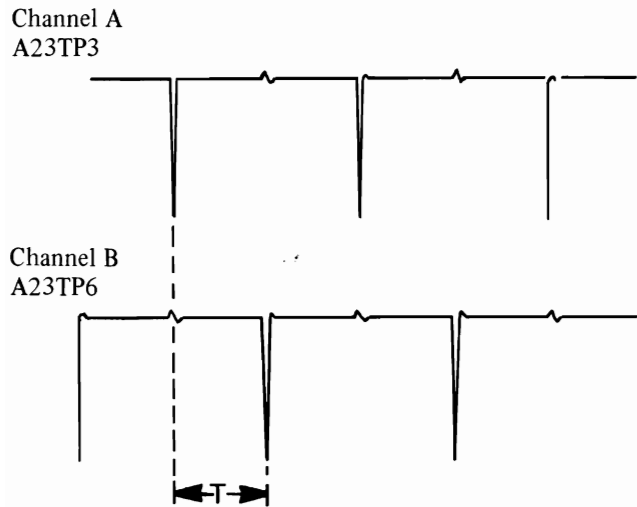

The time "T" is not critical, but the two pulses should not be coincident, and "T" should remain constant. If these conditions are not met, troubleshoot the circuits which precede test points 3 and 6.

j. If the previous check (Step i) is correct, increment the frequency to 0.3 Hz by momentarily pressing FREQ ↑. Channel A (TP3) should drift to the right relative to Channel B (TP6). When the pulses on Channel A and Channel B coincide, they should both disappear momentarily, then reappear. If this does not occur, troubleshoot the blanking circuit (between A23TP2/TP5 and TP14).

k. Connect Channel B of the oscilloscope to A23TP7 (Channel A still connected to A23TP3). Trigger the oscilloscope on Channel A.

l. Set front panel controls as follows:

FREQ 0.2 Hz
 FREQ STEP 0.1 Hz
 TIME/STEP 3000 ms

m. The waveform on Channel A should be as shown below. The waveform on Channel B may be as in either (1), (2), or (3). If Channel B appears as in (2), press FREQ ↓ momentarily. The waveform should drift through a pulse display similar to (1) and then go to 0 V. If not, see Step q. If Channel B appears as in (3), press FREQ ↑ momentarily. The waveform should drift through a pulse display similar to (1), and then go to + 5 V. If not, see Step q.

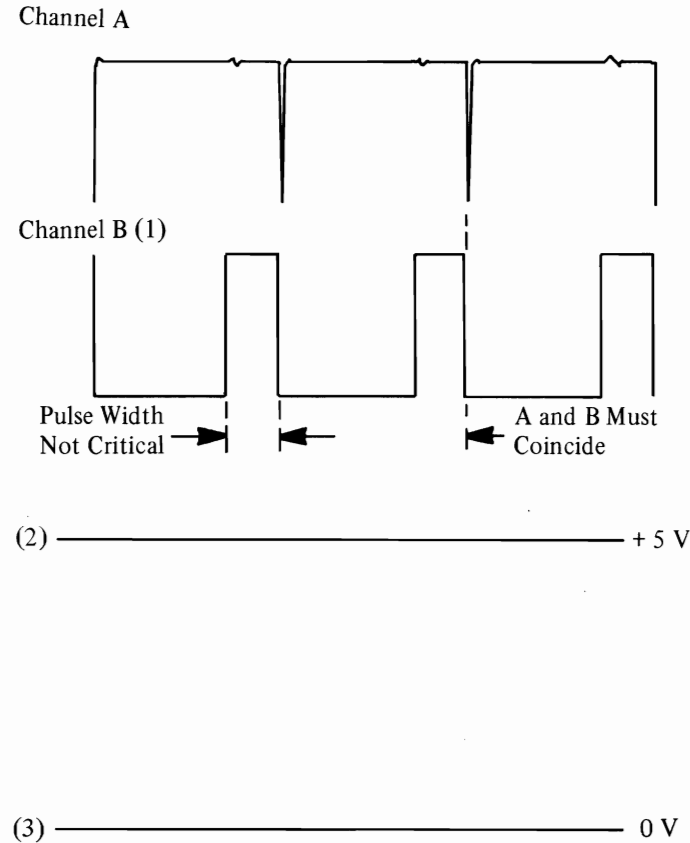

n. If the waveform in (1) appears on Channel B in Step m, the time relationship between A and B should be as shown. If the relationship is not correct, see Step q.

o. If the waveform relationship in Step n is correct, press FREQ ↑ momentarily. Channel B should go to + 5 V (2) and remain. If not, see Step q.

p. If Step o is correct, press FREQ ↓ twice. Channel B should go through a pulse display to 0 V (3) and remain. If not, see Step q.

q. If the conditions of Steps m, n, o, or p are not correct, troubleshoot the diplexer, A23IC7, the ROM, A23IC8, or the J-K flip-flops, A23IC9 and 11.

r. When all of the preceding tests are met, the SL1 Phase Detector is operating correctly. Replace A23 and A25 in the instrument, and return the red cable from the 20 MHz jack to the 1 MHz jack. Return the A9 slide switch to the N4 position.

SL2 PHASE DETECTOR

The following procedure may be used for verification and troubleshooting of the SL2 Phase Detector. The procedure forces the Phase Detector into certain operating conditions and checks for the appropriate outputs. Assembly location is shown in Figure 5-8.

a. Disconnect ac power from the instrument.

b. Remove A9, N4 Counter/Sampler, from the instrument and move the slide switch A9S1 off the N4 position. Replace A9.

c. Remove A22, SL2 VTO, from the instrument.

d. Near the left rear of the instrument, disconnect the red cable from the 1 MHz jack and connect it to the 20 MHz jack. This places a 20 MHz signal on the rear panel 1 MHz OUT connector.

e. Connect a BNC-to-split-pair cable to the rear panel 1 MHz OUT connector. Connect the ground side of the split pair to the 3330A/B chassis, and connect the high side to A21TP12 (see component locator drawing of Schematic No. 8).

f. Mount A21, SL2 Mixer/Phase Detector, on a printed circuit extender.

g. Connect ac power to the instrument and turn front panel switch to ON.

h. Set front panel controls as follows:

FREQ 4000.2 Hz
 FREQ STEP 0.1 Hz
 TIME/STEP 3000 ms

i. Connect Channel A of a dual channel oscilloscope to A21TP6, and connect Channel B to A21TP7. Internally trigger the oscilloscope on Channel B. The following waveforms should be present (each 200 kHz, TTL levels):

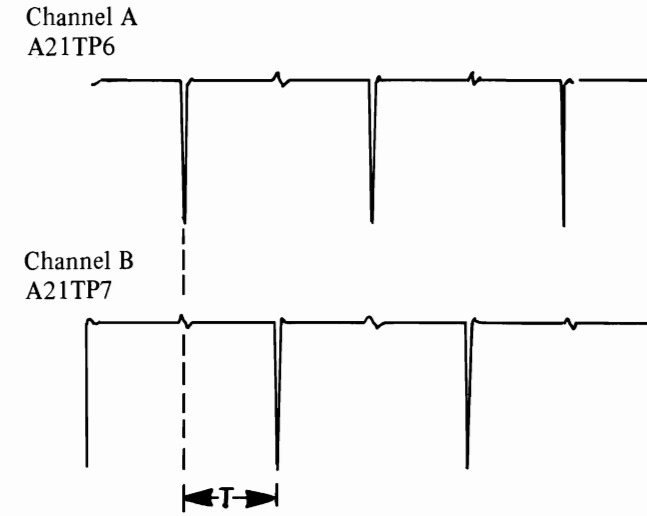

The time "T" is not critical, but the two pulses should not be coincident, and "T" should remain constant. If these conditions are not met, troubleshoot the circuits which precede test points 6 and 7.

j. Change front panel FREQ setting to 4002.0 Hz.

k. Connect Channel B of the oscilloscope to A21TP14.

l. Set the oscilloscope time base to 5 ms/div. The following waveform should be observed on Channel B.

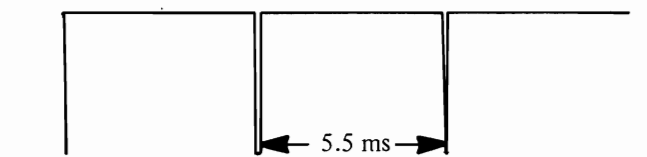

m. Change oscilloscope time base to 2 μs/div. The following waveform should be observed on Channel B.

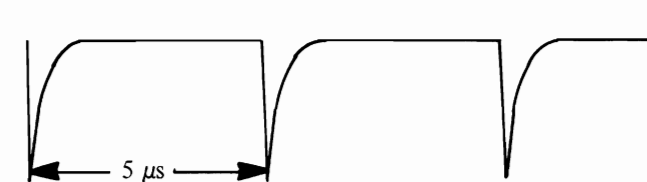

n. If these waveforms are not correct, troubleshoot the pulse blanking circuit (between A21TP4/TP5 and TP14).

o. Connect Channel B of the oscilloscope to A21TP15 (Channel A still connected to A21TP6). Internally trigger the oscilloscope on Channel A.

p. Set front panel controls as follows:

FREQ
 FREQ STEP
 TIME/STEP

q. Set the oscilloscope time base to 2

r. A21TP15 (Channel B) should be low (approximately + 5 V or 0 V). If square wave present, see Step u.

s. If Channel B is at + 5 V in Step once. A square wave should appear for trace should go to 0 V and remain. If FREQ ↑ twice. The square wave should moment, then the trace should go to

p. Set front panel controls as follows:

FREQ 4000.2 Hz
FREQ STEP 0.1 Hz
TIME/STEP 3000 ms

q. Set the oscilloscope time base to 2 μ s/div.

r. A21TP15 (Channel B) should be either a TTL high or low (approximately + 5 V or 0 V). If not, or if there is a square wave present, see Step u.

s. If Channel B is at + 5 V in Step r, press FREQ \downarrow once. A square wave should appear for a moment, then the trace should go to 0 V and remain. If this occurs, press FREQ \uparrow twice. The square wave should reappear for a moment, then the trace should go to + 5 V and remain.

If these results are not obtained, see Step u.

t. If Channel B is at 0 V in Step r, press FREQ \uparrow once. A square wave should appear for a moment, then the trace should go to + 5 V and remain. If this occurs, press FREQ \downarrow twice. The square wave should reappear for a moment, then the trace should go to 0 V and remain. If these results are not obtained, see Step u.

u. If the proper results are not obtained in Steps r, s, or t, troubleshoot the Diplexer, A21IC8, the ROM, A21IC9, or the J-K Flip-Flops, A21IC10 and 11.

v. When all of the preceding tests are met, the SL2 Phase Detector is operating correctly. Replace A21 and A22 in the instrument, and return the red cable from the 20 MHz jack to the 1 MHz jack. Return the A9 slide switch to the N4 position.

AMPLITUDE NOTES

p/o Figure 7-4

2. This check verifies the ability of the unit to deliver full output into a 50 ohm load. Under these conditions, all logic levels into both the Attenuator and the Amplitude Reference are low.
- 3,4. It has been verified that the instrument is delivering full output into a 50 ohm load. This means that, if there are any problems in the Output Section, they must be due either to the Attenuator or the Amplitude Reference. By setting the output to + 5.67 dBm, the number sent to the Amplitude Reference from the Controller is changed from 000 to 777. This change in amplitude setting checks the ability of the Amplitude Reference to respond to a change in bit patterns.
- Before performing this check, it is recommended that Paragraph 5-37 Amplitude Reference (3330B) be performed. If this adjustment cannot be made, proceed to Step 13.
- 5,6. This new amplitude setting further checks the ability of the Amplitude Reference to respond to changing bit patterns.
- 7,8. This setting checks the Controller to see if it is providing the proper information to the Attenuator.
- 9,10. See Note 7,8.
16. Since the display is correct, the problem is in the Controller and must be on the Digital Output board of the Controller. It is possible for the display to be correct while the digital information sent to the Output Section is incorrect. This is because the digital information for the displays comes from a different point than the information which is sent to the Output Section.
17. Since both the display and the digital output to the Output Section are incorrect, the Controller or the Keyboard is faulty (see Note 16).
21. See Note 16.
22. See Note 17.
23. Since the Controller is not providing the correct information to the Attenuator and the display is working correctly, the problem must be on the Digital Output (A5) of the Controller. This is because the digital information to the display from the Controller and the information from the Controller to the Output Section come from different points on the A5 assembly.
24. See Note 17.
28. See Note 23.
29. See Note 17.
- 30,31. *NOTE*
You may put A32B on the extender without removing A31 from A32B. An extender for A31 is not necessary since A31 does not need to be in the circuit for this test.
- The instrument is not delivering the correct voltage into a 50 ohm load. This step checks the input to the Attenuator.
32. See Note 7,8.
35. See Note 23.
36. See Note 17.
- 37,38. The voltage at the input to the Attenuator is incorrect. The purpose of this check is to determine if the Amplitude Reference is functioning properly.
- If the voltage at AL6TP25 is $10 \pm .007$ Vdc, proceed to Step 50.
 - If the voltage at A26TP25 is not within the limits, try adjusting A26R17.
 - If the voltage cannot be set between the limits, proceed to Step 39.
 - If the voltage can be set between the limits, return to Step 1.
- 39,40. The output of the Amplitude Reference is incorrect. The purpose of this check is to remove those circuits which might load the output of the Amplitude Reference.
- If the voltage at A26TP25 is $10 \pm .007$ Vdc, proceed to Step 44.
 - If the voltage at A26TP25 is not within the limits, try adjusting A26R17.
 - If the voltage cannot be set between the limits, proceed to Step 41.
 - If the voltage can be set between the limits, proceed to Step 44.
- 41,42. This checks the logic from the controller to the Amplitude Reference.
- 44,45. Apparently, one of the boards was loading the Amplitude Reference. The purpose of these checks is to determine which board is loading.
53. If the output voltage is low, the Amplitude Reference should try to correct the error by applying a positive voltage greater than + 5.5 Vdc to the Amplitude Modulator.

AMPLITUDE NOTES (Cont'd)

p/o Figure 7-4

54. If the output voltage is high, the Amplitude Reference should try to correct the error by applying a voltage of 0 to -1 volt dc to the Amplitude Modulator.
57. The following procedure is for checking the ability of the Modulator to operate over a 10 dB range. When A29SW1 is in the open position, the leveling loop is broken. The pretune signal from the Amplitude Reference is then used to check the ability of the Modulator to operate over a 10 dB range.
- a. Move the switch on A29 to the open position.
 - b. Set the the amplitude to +13.44 dBm.
 - c. Record the peak-to-peak amplitude of the signal at XA29 pin labeled 20 MHz Mix.
 - d. Set amplitude to +3.45 dBm. Record the peak-to-peak Amplitude at XA29 pin labeled 20 MHz.
 - e. In Steps c and d is the following ratio

$$\text{ratio} = \frac{\text{amplitude at } +3.45 \text{ dBm}}{\text{amplitude at } +13.44 \text{ dBm}}$$
58. With A29SW1 open:
- a. Remove A28 (set Amplitude to any level)
 - b. Ground XA29 pin labeled AERR
 - c. At A29TP2, is the voltage 0 Vdc to -1.0 Vdc? If no, go to Step 61. If yes, go to Step d.
 - d. Remove ground from XA29 pin labeled AERR.
 - e. Put A28 in unit.
 - f. Set Amplitude to +13.44 dBm.
 - g. Ground XA29 pin labeled 20MHz MIX.
 - h. At A29TP2 is voltage greater than +5.5 Vdc?
60. See Note 57.
66. See Note 23.
67. See Note 17.
70. The purpose of this check is to determine if the leveling circuitry is working properly.
71. The purpose of this check is to determine if the problem is in the LEVELING switch or in the Controller. One of these must be defective since logic applied to the leveling loop by the Controller was incorrect.
74. The purpose of this check is to determine if the relay on the Output Amplifier board (A32) is switching properly.
76. The purpose of this check is to see if the relay K1 on the Amplitude Detector/Comparator is working properly.

Table 1. Logic Weights for A26.
(all available on Motherboard)

Amplitude setting (dBm)	Logic Weights											
	800A	400A	200A	100A	80A	40A	20A	A10	A8	A4	A2	A1
+ 4.56	1	0	0	0	1	0	0	0	1	0	0	0
+ 5.67	0	1	1	1	0	1	1	1	0	1	1	1
+ 13.44	0	0	0	0	0	0	0	0	0	0	0	0

Table 2. Logic Weights for A31.
(all available on Motherboard)

Amplitude setting (dBm)	Logic Weights			
	8K	4K	2K	1K
+ 13.44	0	0	0	0
- 60.00	0	1	1	1
- 70.00	1	0	0	0

Check XA31 pin labeled SU. If this pin is LOW, replace A19.

Table 3. Control Logic.

Leveling	AC1	AC2
OFF	1	1
SLOW	0	0
FAST	1	0

Perform this check for each setting of leveling switch.

Table 4. Switch Logic.

Leveling	A	B
OFF	1	1
SLOW	0	0
FAST	1	0

Perform this check for each setting of the leveling switch.

ENTER HERE

NOTE

The number in the upper left-hand corner of each box on the troubleshooting tree corresponds to the number in the troubleshooting tree notes. These notes contain additional information concerning the procedure to be performed.

1. Program the 3330B as follows:
AMPL +13.44 dBm
FREQ 10 kHz
LEVELING FAST (> 1 kHz)

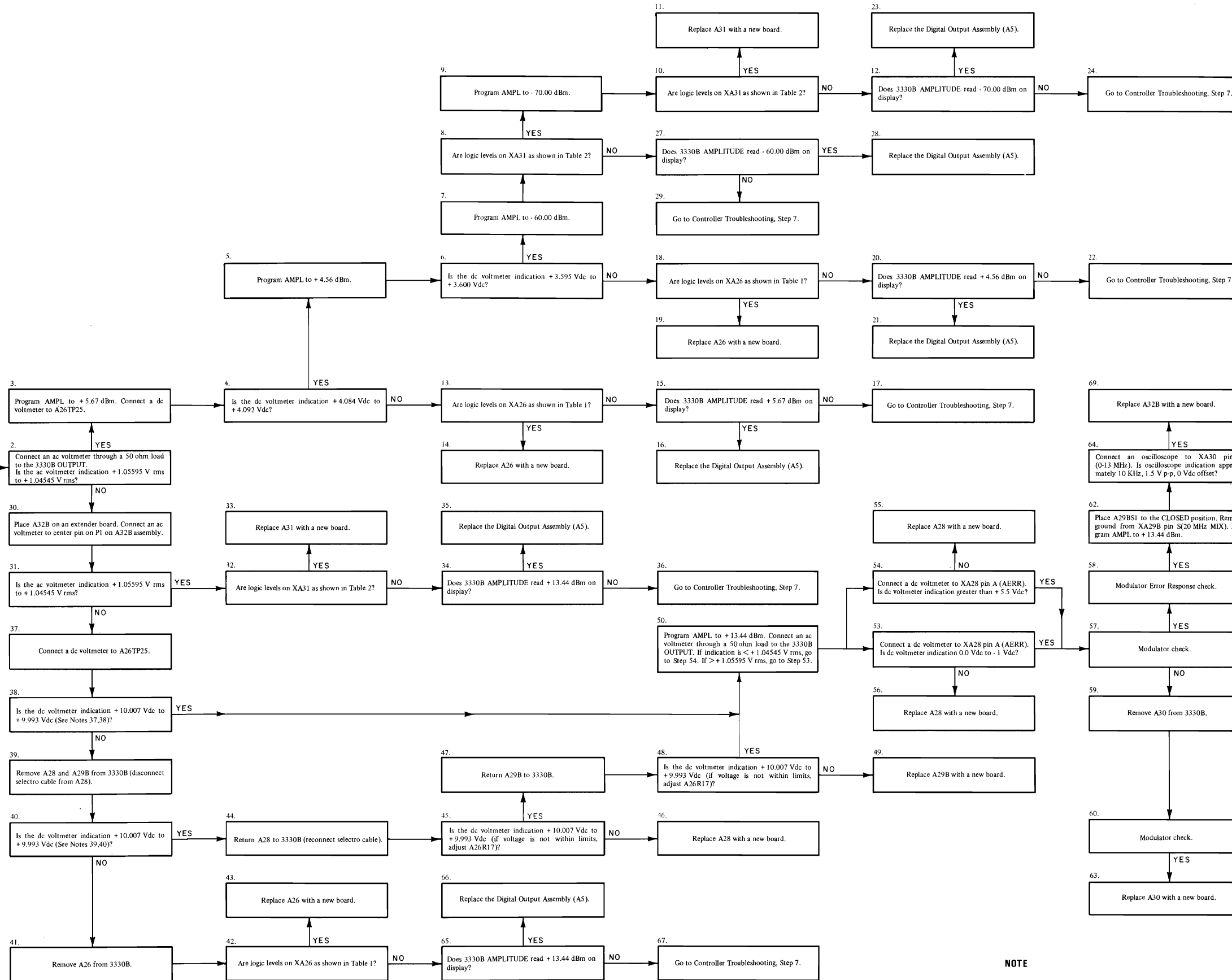

NOTE

The number in the upper left-hand corner of each box on the troubleshooting tree corresponds to the number in the troubleshooting tree notes. These notes contain additional information concerning the procedure to be performed.

corner of each
responds to the
notes. These
concerning the

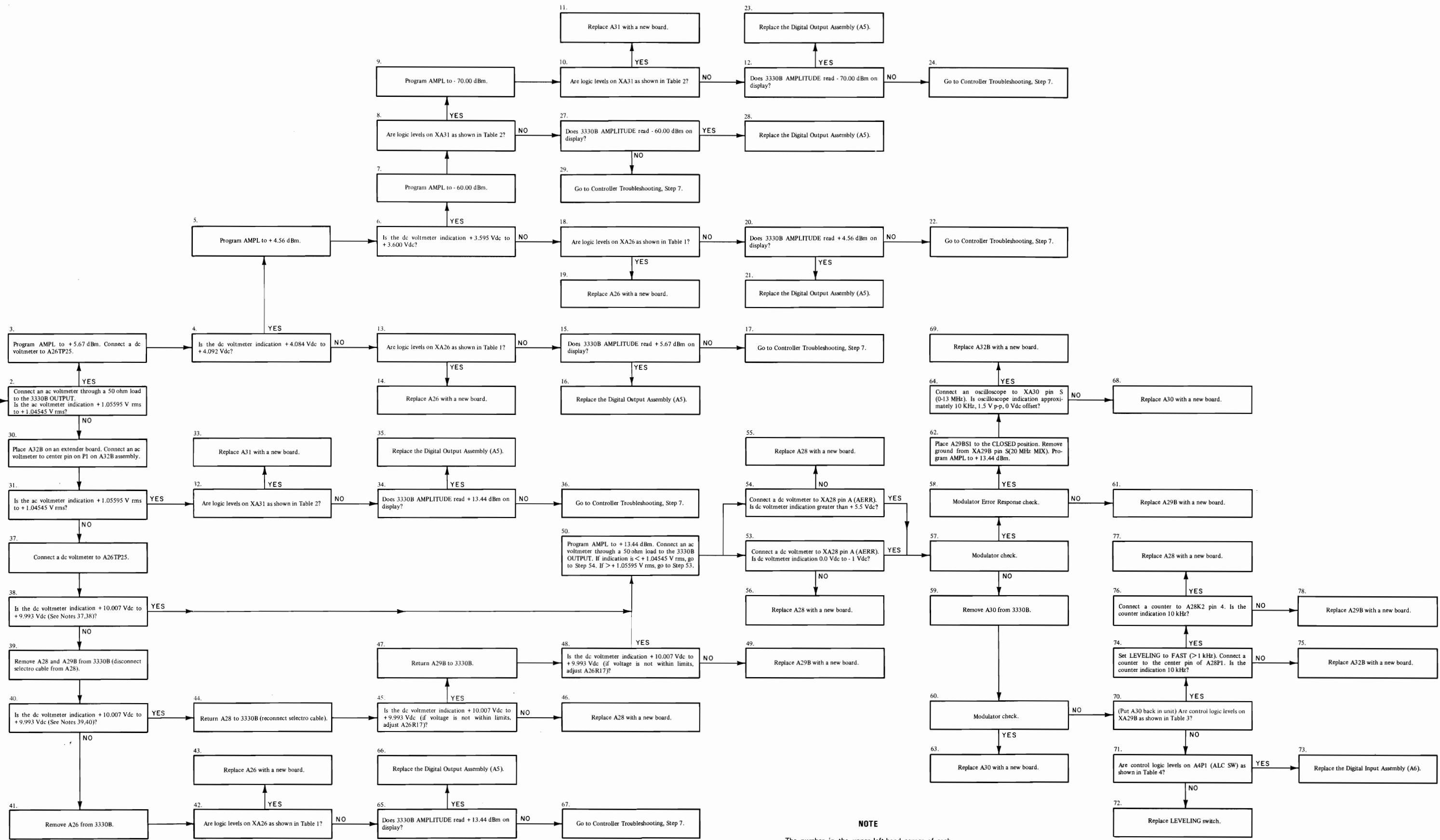

NOTE
The number in the upper left-hand corner of each box on the troubleshooting tree corresponds to the number in the troubleshooting tree notes. These notes contain additional information concerning the procedure to be performed.

Figure 7-4. Amplitude Troubleshooting Tree. 7-17/7-18

CONTROLLER-KEYBOARD ISOLATION

You should have arrived at this check through either the Controller Troubleshooting, the Frequency Section Troubleshooting, the Amplitude Section Troubleshooting, or the observation that the unit will not sweep Frequency and/or Amplitude. Perform the following checks in the order in which they are presented.

move any of the other sweep function switches when checking Pin 2.

If the logic levels for Pin 2 are as shown in Table 2, perform Steps a and b for the next pin.

1. Check Pin 10 of the KEYBOARD connector at the front of the Mother Board (A4). (This is a 14 pin connector on the Mother Board and is labeled with the words KEYBOARD. (Pin 1 is also labeled.) With the unit in local, Pin 10 should be low (logic probe light OFF). If this pin is high, replace the Digital Input Assembly (A6). If this Pin is low, proceed to Check 2.
2. The purpose of this check is to determine if the keys and their associated circuitry are functioning properly. The following procedure explains the use of Table 1 to accomplish this objective:
 - a. Press the first key (FREQ) in Table 1.
 - b. With FREQ pressed, check Pins 1 thru 6 on the KEYBOARD connector with the -hp- Logic probe. If the logic levels for Pins 1 thru 6 are not as shown in Table 1, the Keyboard (A1) is faulty. If the logic levels are correct, proceed to Step c.
 - c. With FREQ pressed, connect the logic probe to Pin 9. Now release FREQ. The light on the logic probe should go ON. If this does not happen, the Keyboard (A1) is faulty. If the light does go ON, proceed to Step d.
 - d. Repeat Steps a thru c for the remaining keys. If all keys produce the required Logic States at the Keyboard connector, proceed to Check 3. If not; replace Keyboard.
3. The purpose of this check is to verify that the front panel slide switches are functioning properly. The following procedure uses Table 2 to verify proper operation of the slide switches. The “ ” in Table 2 represents a “don’t care” situation. All of the pins listed in Table 2 are located on the 14-pin SLIDE SW Connector at the front of the Mother Board. On the bottom of this connector, the Mother Board is labeled SLIDE SW, and Pin 1 is labeled.
 - a. Place the logic probe on Pin 2 of the SLIDE SW connector.
 - b. Move the TIME/STEP slide switch through each of the positions under the Switch Position column in Table 2. (The switch should be moved through the positions 3000, 1000, 300, 100, 30, 10, 3, and 1.) It is not necessary to

Table 1. Keyboard.

Key	Code	Pins on KEYBOARD Connector (See Bottom of Mother Board)						9 when released
		1	2	3	4	5	6	
FREQ	14	0	1	1	0	1	1	0-1
FREQ STEP	15	0	1	1	0	1	0	0-1
AMPL	16	0	1	1	0	0	1	0-1
AMPL STEP	17	0	1	1	0	0	0	0-1
0	60	1	0	0	1	1	1	0-1
1	61	1	0	0	1	1	0	0-1
2	62	1	0	0	1	0	1	0-1
3	63	1	0	0	1	0	0	0-1
4	64	1	0	0	0	1	1	0-1
5	65	1	0	0	0	1	0	0-1
6	66	1	0	0	0	0	1	0-1
7	67	1	0	0	0	0	0	0-1
8	70	0	0	0	1	1	1	0-1
9	71	0	0	0	1	1	0	0-1
.	72	0	0	0	1	0	1	0-1
Hz	75	0	0	0	0	1	0	0-1
kHz	76	0	0	0	0	0	1	0-1
MHz	77	0	0	0	0	0	0	0-1
+ dBm	73	0	0	0	1	0	0	0-1
- dBm	74	0	0	0	0	1	1	0-1
FREQ STEP X10	40	1	1	0	1	1	1	0-1
FREQ STEP ÷10	41	1	1	0	1	1	0	0-1
FREQ STEP X2	44	1	1	0	0	1	1	0-1
FREQ STEP ÷2	45	1	1	0	0	1	0	0-1
AMPL STEP X10	42	1	1	0	1	0	1	0-1
AMPL STEP ÷10	43	1	1	0	1	0	0	0-1
AMPL STEP X2	46	1	1	0	0	0	1	0-1
AMPL STEP ÷2	47	1	1	0	0	0	0	0-1
FREQ ↑	52	0	1	0	1	0	1	0-1
FREQ ↓	53	0	1	0	1	0	0	0-1
AMPL ↑	51	0	1	0	1	1	0	0-1
AMPL ↓	50	0	1	0	1	1	1	0-1
STOP	30	0	0	1	1	1	1	0-1
START CONT	31	0	0	1	1	1	0	0-1
START SINGLE	33	0	0	1	1	0	0	0-1
FIRST POINT	32	0	0	1	1	0	1	0-1

CONTROLLER-KEYBOARD ISOLATION

If the logic levels are not as shown in Table 2 for all pins, there is a problem on the SLIDE SWITCH BOARD (A2). If you have checked all the indicated pins and no failures were indicated, proceed to Step c.

- c. Connect the logic probe to Pin 6. Then, move each of the following switches through each of its positions. Note if the logic probe blinks high momentarily as each switch is moved from one position to the next.

Switch Functions to be checked

Mode (AMP - FREQ)

STEPS

Direction (UP, BOTH, DOWN)

If the unit passes this check, proceed to Step d. If the unit does not pass this check, the slide switch board (A2) is faulty.

- d. Follow the instructions for Step c. Except, check Pin 7 instead of 6. The logic probe should be high and blink momentarily low in this case. The TIME/STEP switch, in addition to the switch functions listed in Step c, should be checked. If the unit passes this check, proceed to Step e. If the unit does not pass this test, the problem is in the Controller.

- e. Check Pin 4 on the SLIDE SW connector. With the unit in local, Pin 4 should be high. If the unit fails this check, there is a problem in

the Controller. If the unit passes this check, proceed to Step f.

- f. Connect the logic probe to Pin 5 of the SLIDE SW connector. Turn the front panel LINE switch to OFF. The logic probe light should be ON. Turn the LINE to OFF. The logic probe should blink OFF momentarily, then come back ON. If this does not happen, there is a problem on A19. Replace A19.
4. If the unit has passed all these checks, the keyboard is working properly.

Table 2. Slide Switches.

Sweep Function Switches	Switch Position	Pin Numbers							
		2	3	9	10	11	12	13	14
SWEEP Direction	UP	-	-	-	-	-	0	-	1
	BOTH	-	-	-	-	-	1	-	1
	DOWN	-	-	-	-	-	1	-	0
Number of STEPS	1000	-	-	1	-	1	-	-	-
	100	-	-	0	-	1	-	-	-
	10	-	-	0	-	0	-	-	-
SWEEP Mode	FREQ	-	-	-	-	-	-	0	-
	AMPL	-	-	-	-	-	-	1	-
TIME/STEP	3000	1	1	-	1	-	-	-	-
	1000	1	1	-	0	-	-	-	-
	300	1	0	-	1	-	-	-	-
	100	1	0	-	0	-	-	-	-
	30	0	1	-	1	-	-	-	-
	10	0	1	-	0	-	-	-	-
	3	0	0	-	1	-	-	-	-
1	0	0	-	0	-	-	-	-	

SCHEMATIC NOTES

1. PARTIAL REFERENCE DESIGNATIONS ARE SHOWN. PREFIX WITH ASSEMBLY OR SUBASSEMBLY DESIGNATION(S) OR BOTH FOR COMPLETE DESIGNATION.

2. COMPONENT VALUES ARE SHOWN AS FOLLOWS UNLESS OTHERWISE NOTED.

RESISTANCE IN OHMS
CAPACITANCE IN MICROFARADS
INDUCTANCE IN MICROHENRYS

3.  DENOTES FLOATABLE CIRCUIT GROUND.

4.  DENOTES ASSEMBLY CIRCUIT GROUND.

5.  DENOTES CHASSIS CIRCUIT GROUND.

6.  DENOTES POWER LINE GROUND.

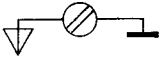
7.  DENOTES SCREWDRIVER GROUND.

8.  DENOTES ASSEMBLY.

9. **7** DENOTES SIGNAL DESTINATION.

10.  DENOTES FRONT PANEL MARKING.

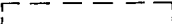
11.  DENOTES SIDE AND REAR PANEL MARKING.

12.  DENOTES SCREWDRIVER ADJUST.

13.  DENOTES WIRE COLOR; COLOR CODE SAME AS RESISTOR COLOR CODE. FIRST NUMBER IDENTIFIES BASE COLOR, SECOND NUMBER IDENTIFIES WIDER STRIP, THIRD NUMBER IDENTIFIES NARROWER STRIP.

(e.g.  = WHITE, RED, YELLOW.)

14. * AVERAGE VALUE SHOWN, OPTIMUM VALUE SELECTED AT FACTORY.

15. SCHEMATIC DIAGRAMS INCLUDE ALL OPTIONS.

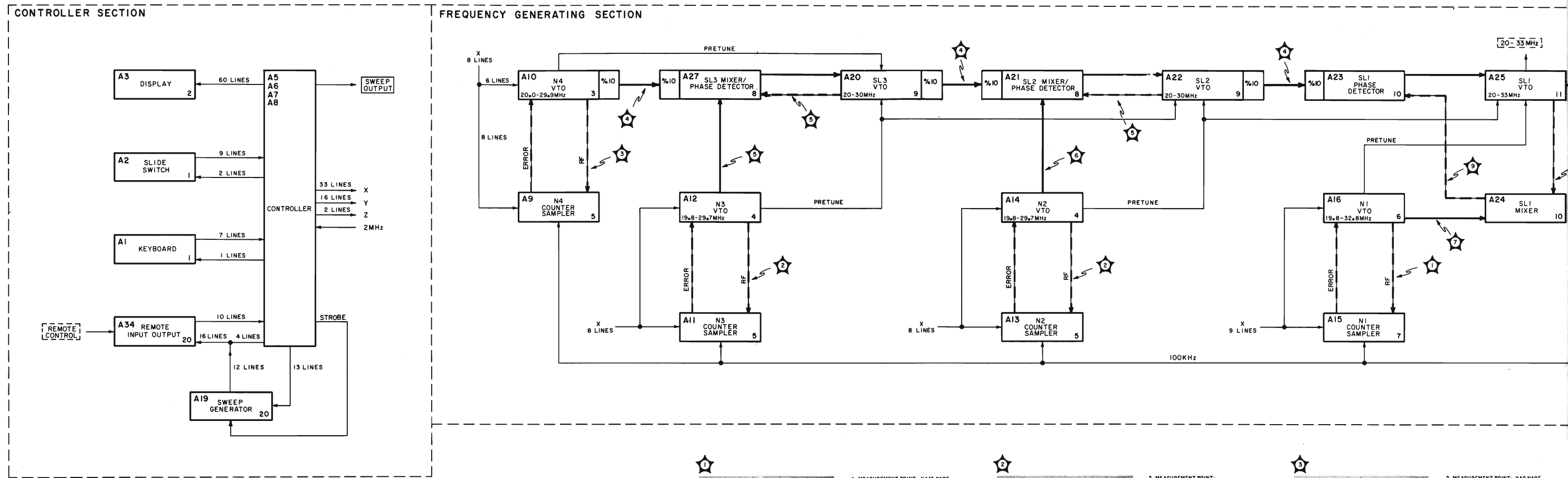

NOTE
 FOR ALL WAVEFORMS, THE 3330A/B SHOULD BE PROGRAMMED FOR MAXIMUM OUTPUT VOLTAGE AT 12.777777 MHz. ALL WAVEFORM MEASUREMENTS WERE MADE WITH RESPECT TO CHASSIS GROUND USING AN OSCILLOSCOPE WITH A 10:1 PROBE. A VARIATION OF 10% SHOULD BE ALLOWED IN ALL VOLTAGE INDICATIONS. ALL MEASUREMENT POINTS DESIGNATED ARE AVAILABLE ON BOTTOM OF MOTHER BOARD.

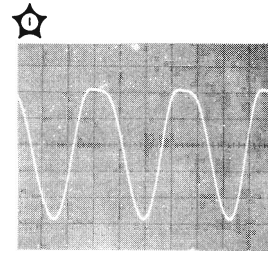
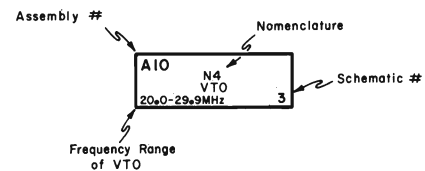

1. MEASUREMENT POINT: XA15 N1RF
 OSCILLOSCOPE SETTINGS:
 VOLTS/DIV .01
 TIME/DIV .1 μsec
 HORIZONTAL MAG X10

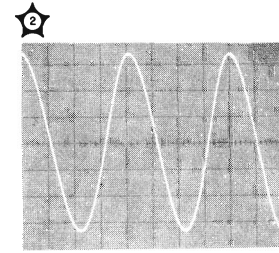

2. MEASUREMENT POINT: XA13 N2RF, XA11 N3RF
 OSCILLOSCOPE SETTINGS:
 VOLTS/DIV .01
 TIME/DIV .1 μsec
 dc OFFSET 0.62 V
 HORIZONTAL MAG X10

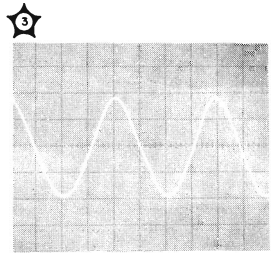

3. MEASUREMENT POINT: XA9 N4RF
 OSCILLOSCOPE SETTINGS:
 VOLTS/DIV .01
 TIME/DIV .1 μsec
 dc OFFSET 0.7 V
 HORIZONTAL MAG X10

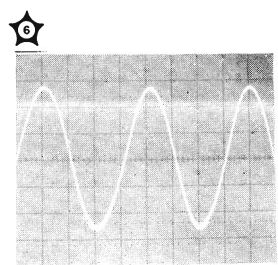

6. MEASUREMENT POINT: XA21 N2SL2RF
 OSCILLOSCOPE SETTINGS:
 VOLTS/DIV .005
 TIME/DIV .1 μsec
 HORIZONTAL MAG X10

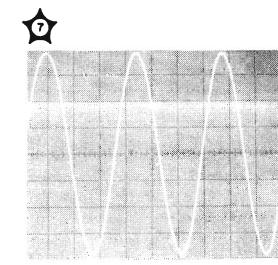

7. MEASUREMENT POINT: XA24 N1SL1RF
 OSCILLOSCOPE SETTINGS:
 VOLTS/DIV .005
 TIME/DIV .1 μsec
 HORIZONTAL MAG X10

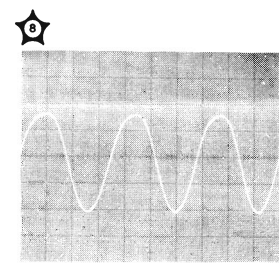

8. MEASUREMENT POINT: XA24 SL1RF
 OSCILLOSCOPE SETTINGS:
 VOLTS/DIV .01
 TIME/DIV .1 μsec
 HORIZONTAL MAG X10

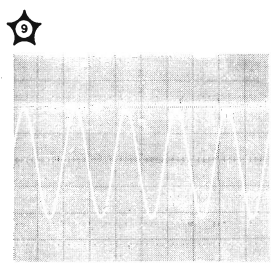

9. MEASUREMENT POINT: XA23 IF
 OSCILLOSCOPE SETTINGS:
 VOLTS/DIV .05
 TIME/DIV 2 μsec
 HORIZONTAL MAG X1
 dc OFFSET 7.75 V

[20-33 MHz]

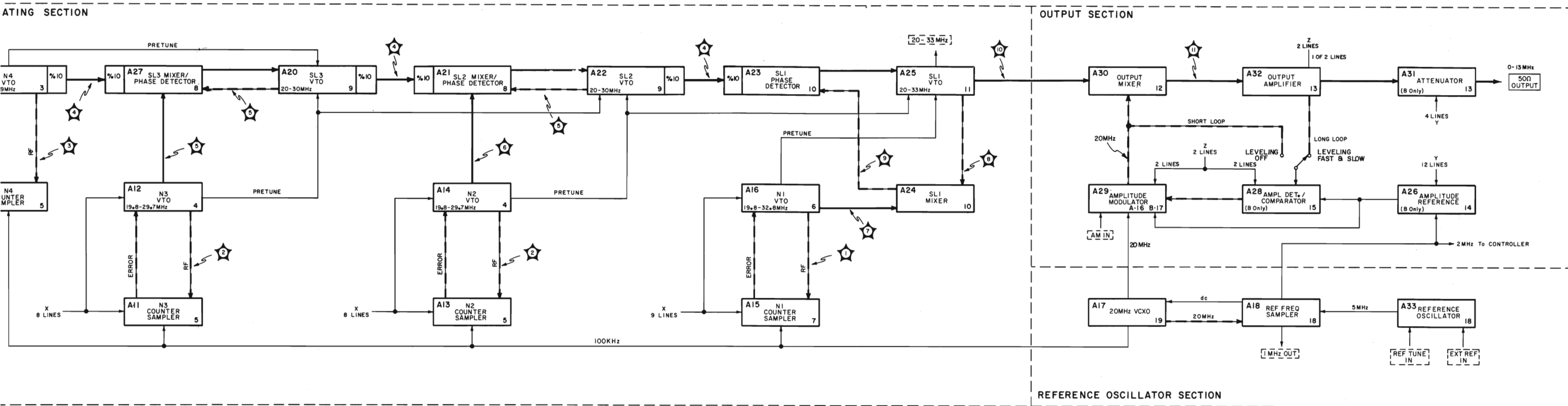

3350A-J-2887

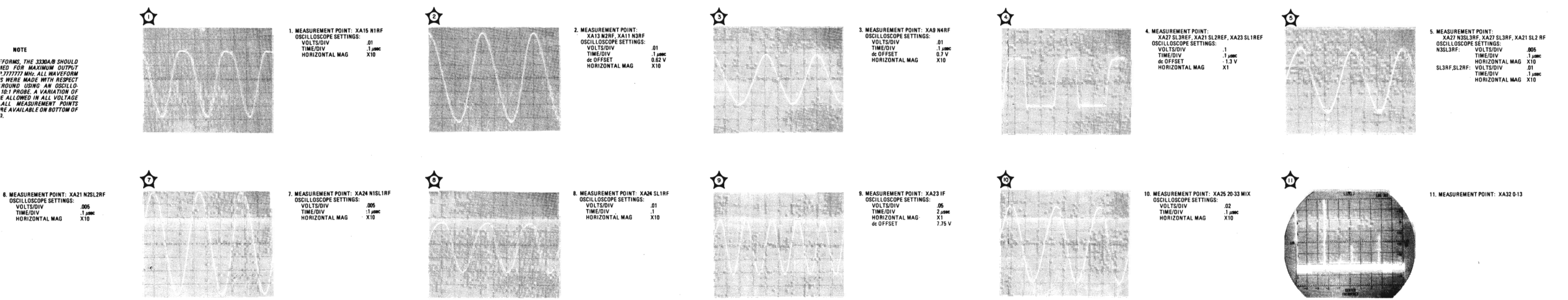
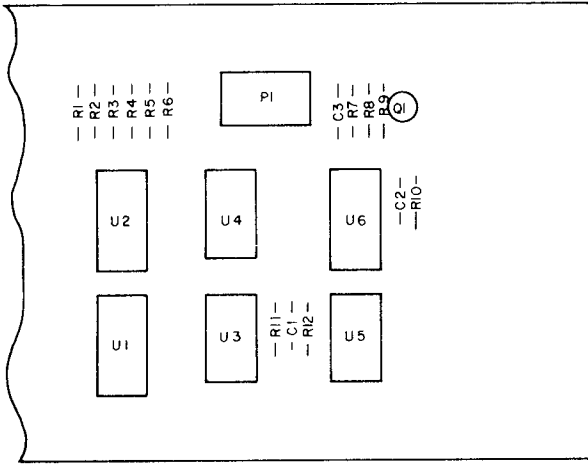
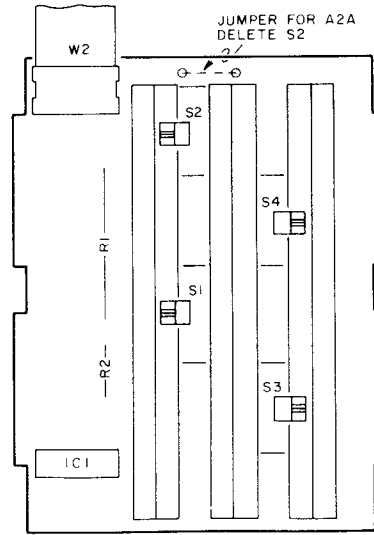

Figure 7-5. Functional Block Diagram and Schematic Notes. 7-21/7-22



AIB
hp Part No 03330-66580



A2B
hp Part No 03330-66502

A2A
hp Part No 03330-66568

A1U1 Decoder

Inputs			Outputs							
C	B	A	0	1	2	3	4	5	6	7
L	L	L	H	H	H	H	H	H	H	H
L	L	H	H	L	H	H	H	H	H	H
L	H	L	H	H	L	H	H	H	H	H
L	H	H	H	H	H	L	H	H	H	H
H	L	L	H	H	H	H	L	H	H	H
H	L	H	H	H	H	H	H	L	H	H
H	H	L	H	H	H	H	H	H	L	H
H	H	H	H	H	H	H	H	H	H	L

A1U2 Data Selector

Inputs			Output
C	B	A	Y
L	L	L	D0
L	L	H	D1
L	H	L	D2
L	H	H	D3
H	L	L	D4
H	L	H	D5*
H	H	L	D6
H	H	H	D7*

*These outputs not used.

A1U3, U4 Counter

Count	Outputs			Octal Coded* Output To Digital Control
	D	C	B	
0	L	L	L	7
1	L	L	H	6
2	L	H	L	5
3	L	H	H	4
4	H	L	L	3
5	H	L	H	2
6	H	H	L	1
7	H	H	H	0

*Low True Logic Output

AIB KEYBOARD 03330-66580 (B Model)

AIA SEE BACKDATING

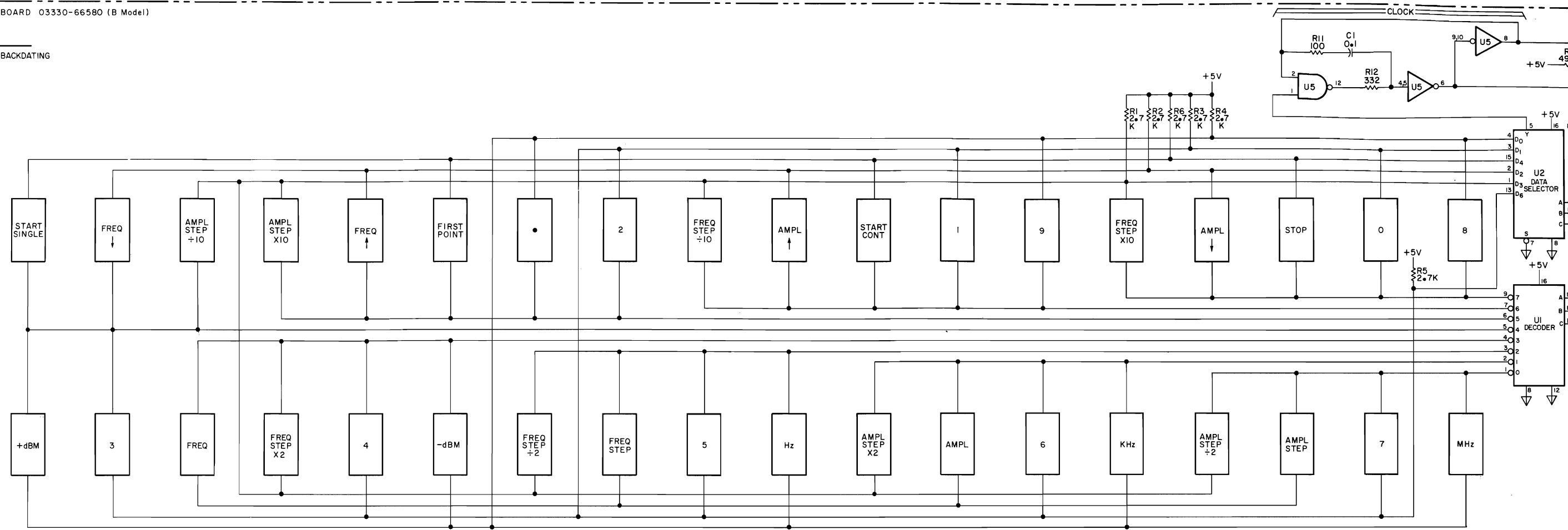

NOTE 1

03330-66576 (3330B STANDARD)
03330-66577 (3330B OPTION 004)
03330-66578 (3330B STANDARD)
03330-66579 (3330B OPTION 004)

A2B SLIDE SWITCH 03330-66502 (B Model)

A2A SLIDE SWITCH 03330-66568 (A Model)

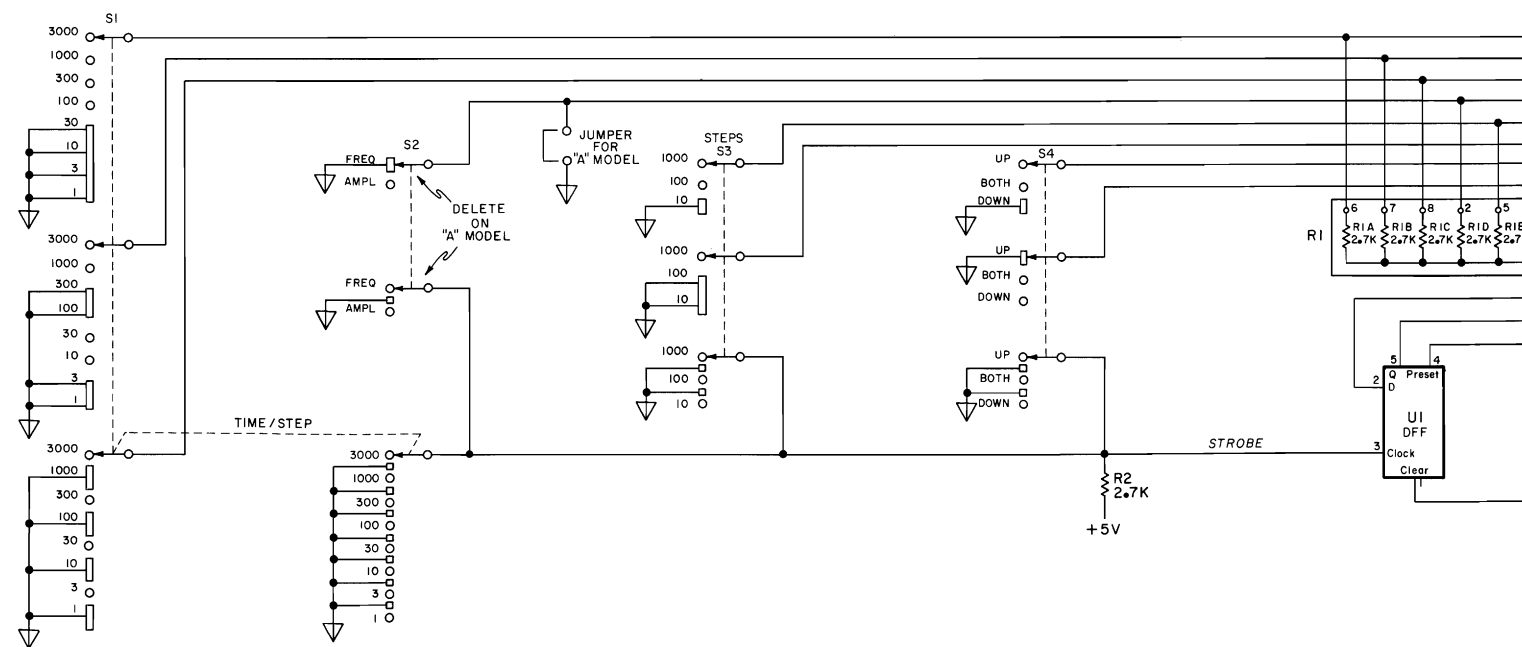
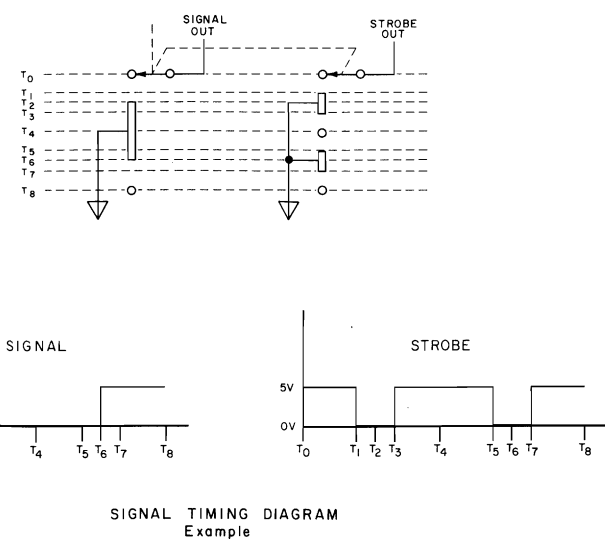

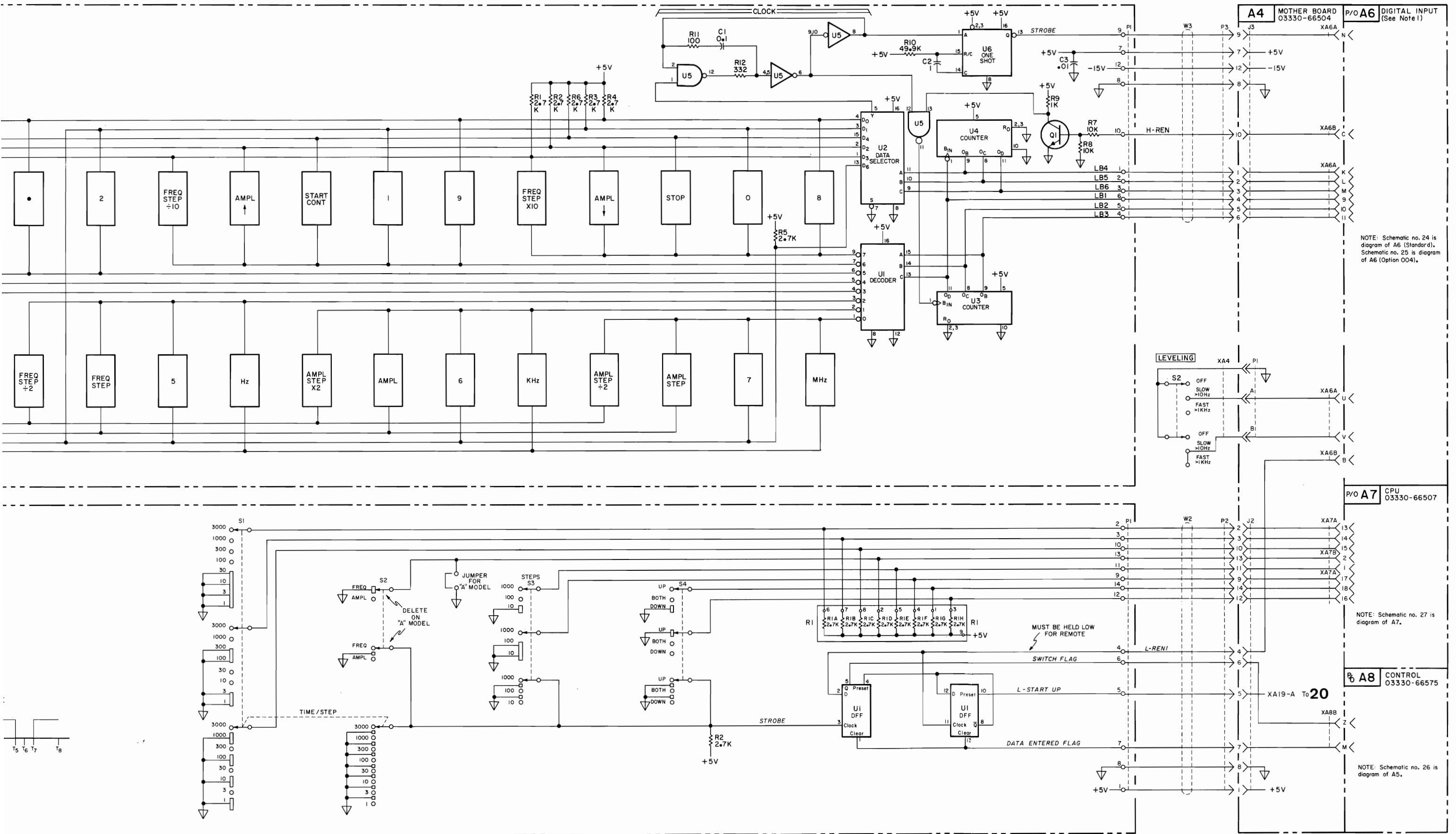

NOTE: Schematic no. 24 is diagram of A6 (Standard). Schematic no. 25 is diagram of A6 (Option 004).

P/O A7 CPU 03330-66507

NOTE: Schematic no. 27 is diagram of A7.

A8 CONTROL 03330-66575

NOTE: Schematic no. 26 is diagram of A5.

3330A-J-2752

Figure 7-6. Keyboard A1A, A1B Slide Switch A2A, A2B. 7-23/7-24

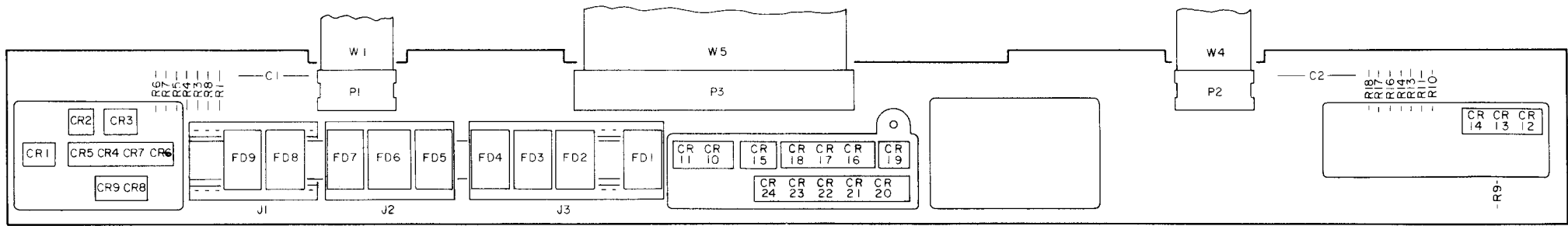

3330A-B-2798

A3A
hp Part No. 03330-66569

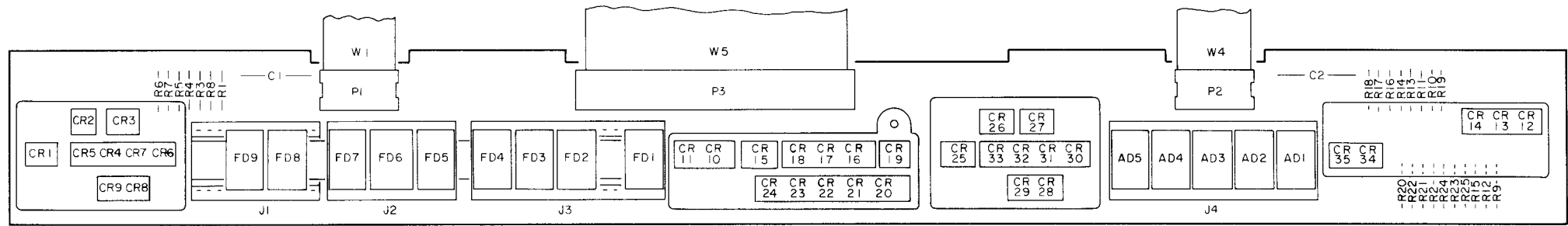

3330A-B-2798

A3B
hp Part No. 03330-66503

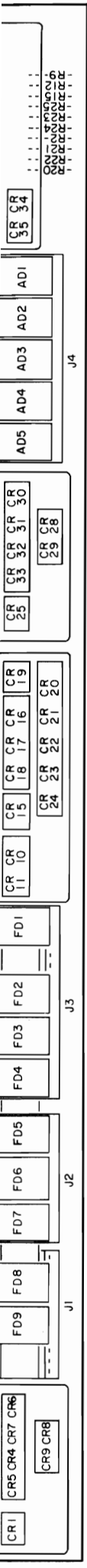

A3B
hp Part No. 03330-66503

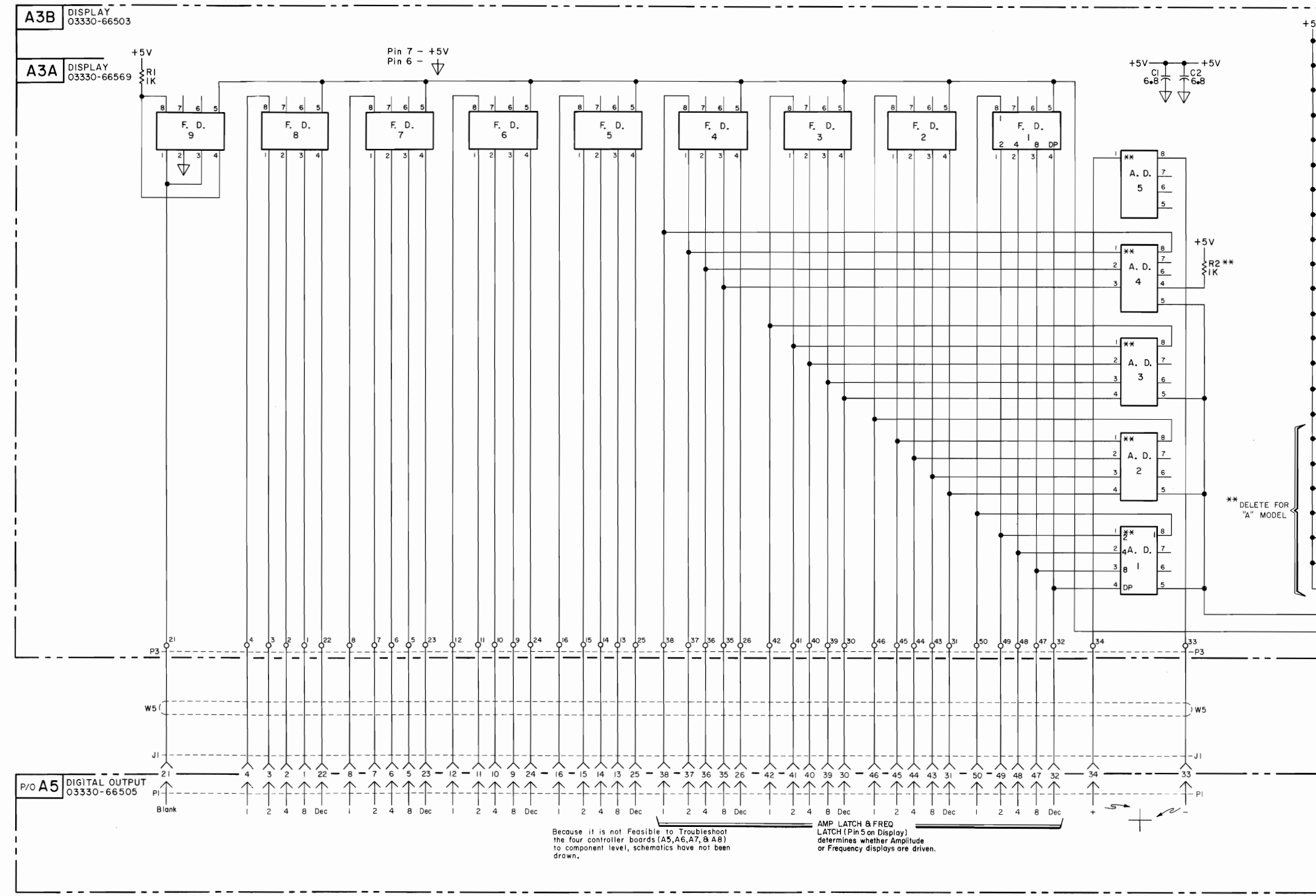
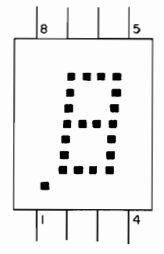

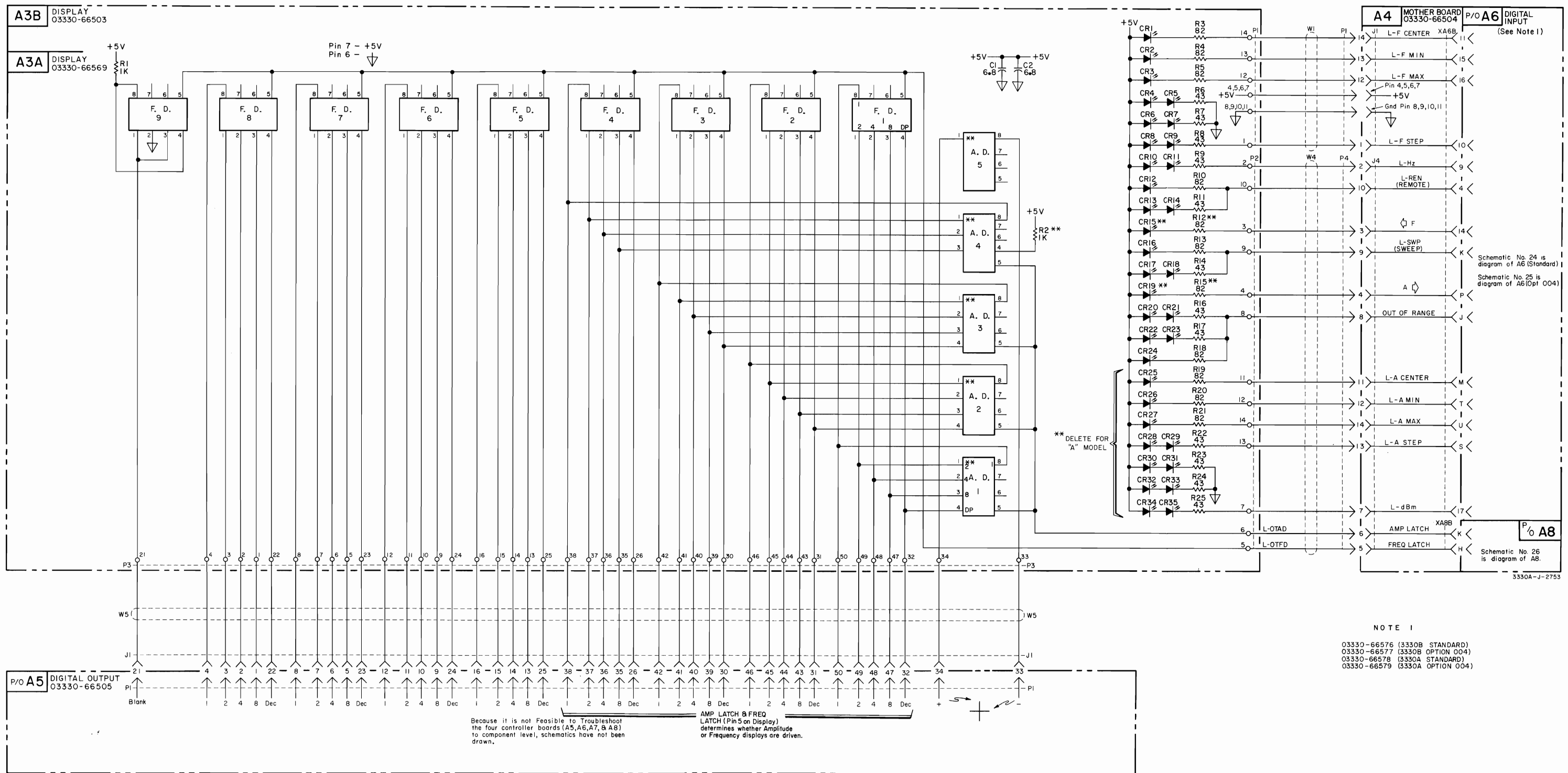

COPYRIGHT 1972 BY HEWLETT-PACKARD COMPANY

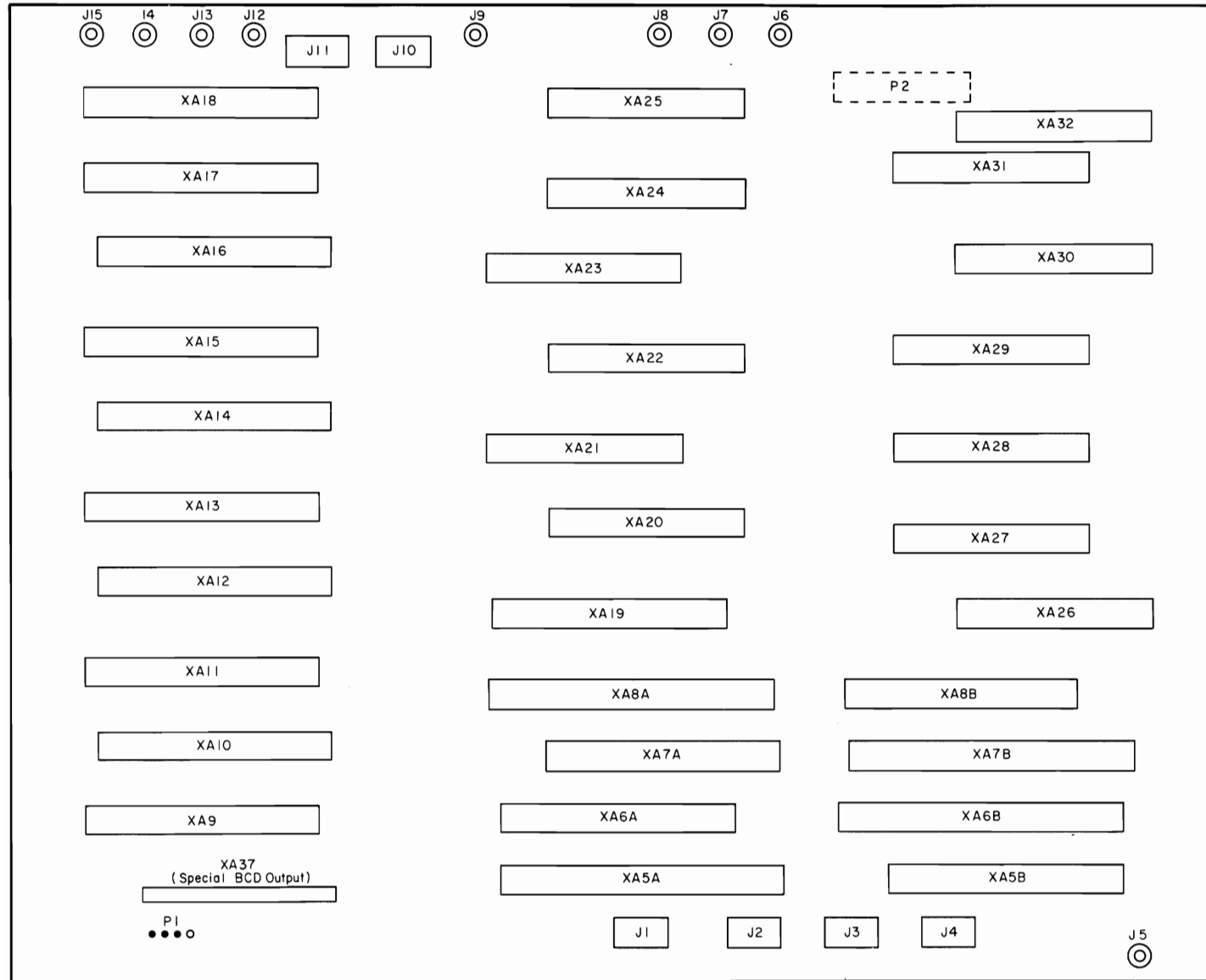

3330A-C-2877

A4
hp Part No. 03330-66504

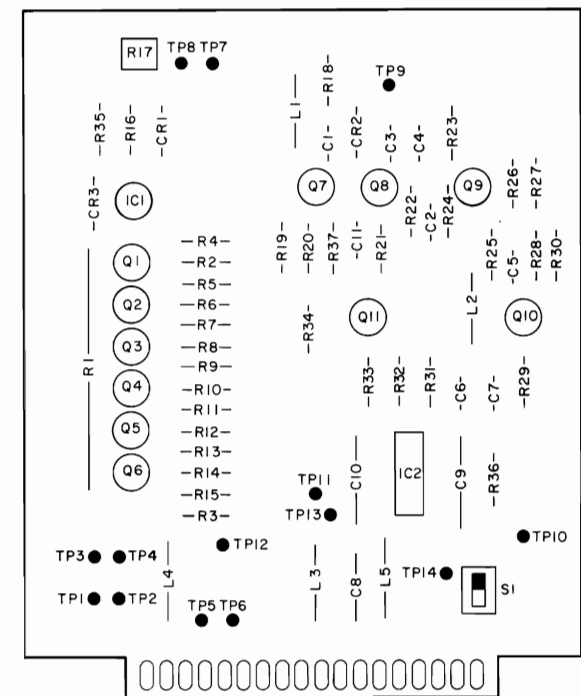

3330A-B-2782

A10
hp Part No. 03330-66509

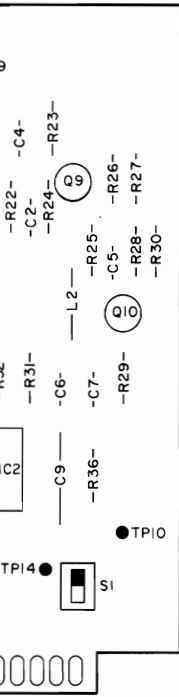
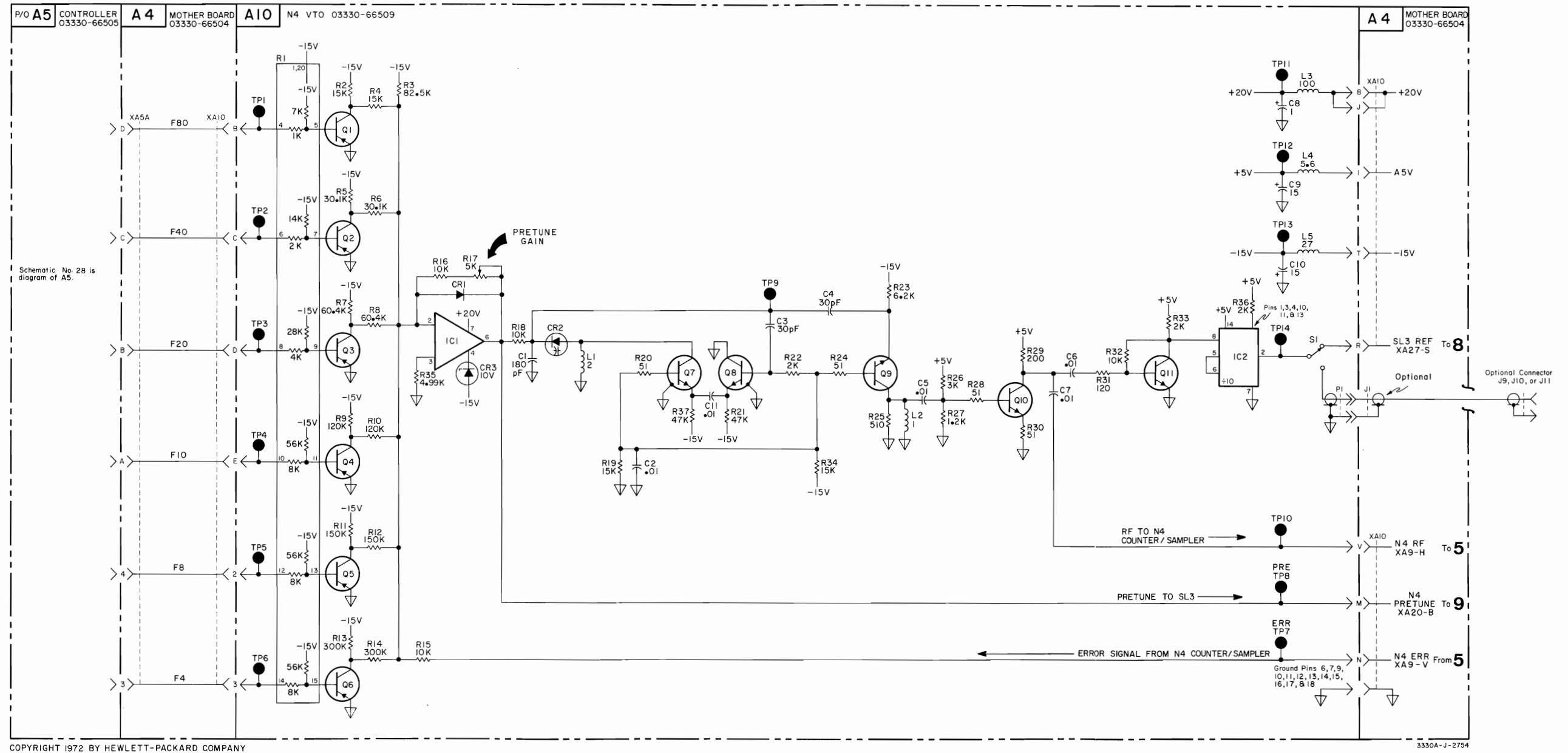

6509

Figure 7-8. N4 VTO A10. 7-27/7-28

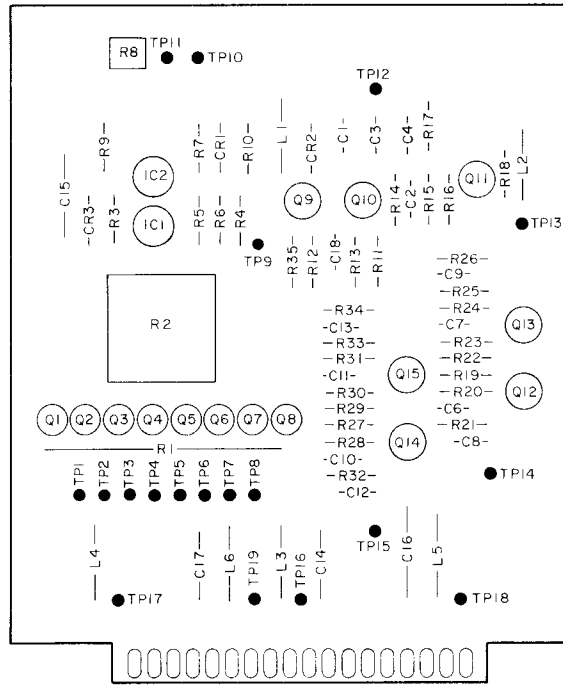

3330A-B-2784

A12, A14

hp Part No. 03330-66511

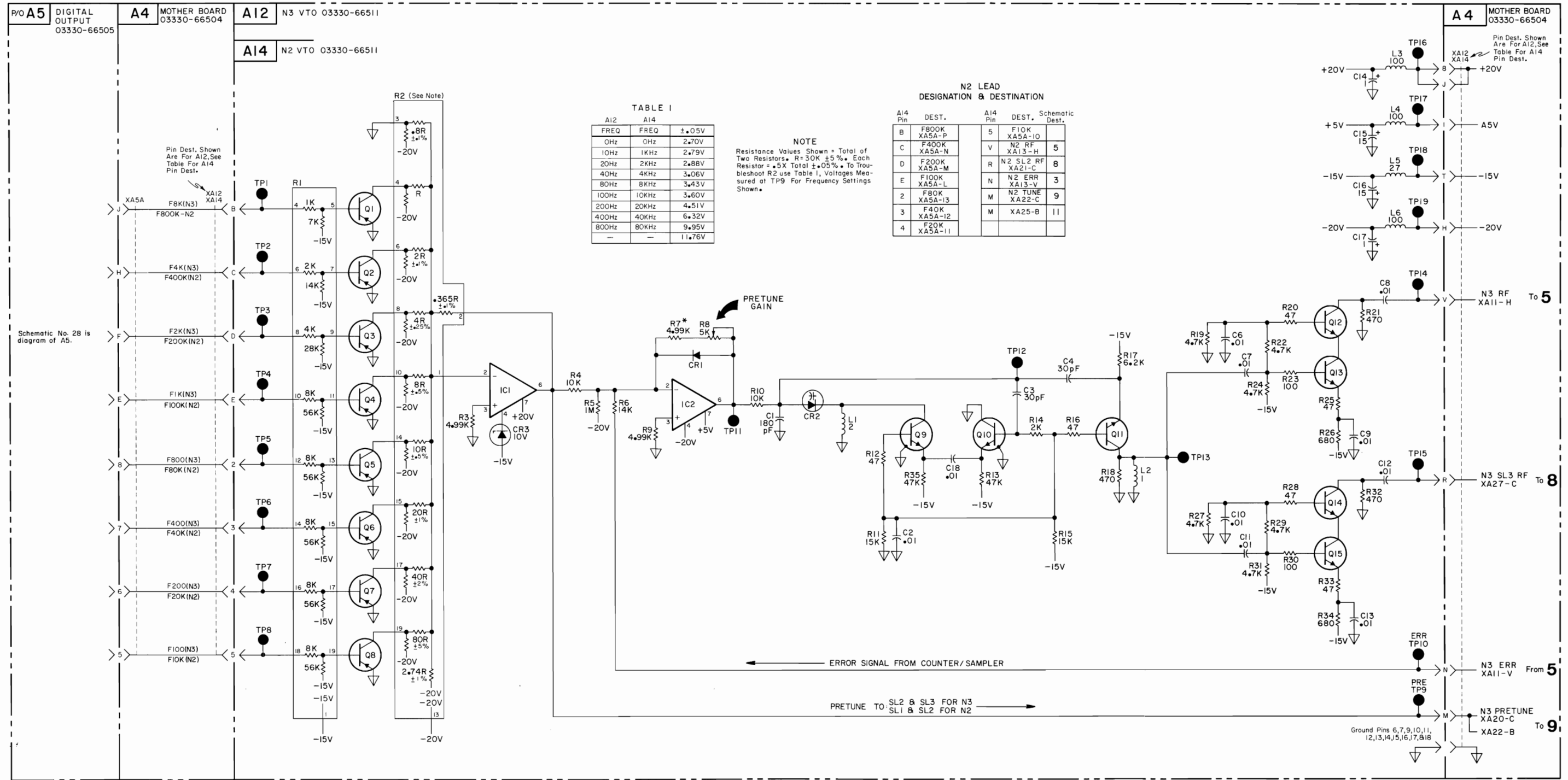

TABLE I

A12 FREQ	A14 FREQ	$\pm 0.5V$
0Hz	0Hz	2.70V
10Hz	1KHz	2.79V
20Hz	2KHz	2.88V
40Hz	4KHz	3.06V
80Hz	8KHz	3.43V
100Hz	10KHz	3.60V
200Hz	20KHz	4.51V
400Hz	40KHz	6.32V
800Hz	80KHz	9.95V
-	-	11.76V

NOTE
Resistance Values Shown = Total of Two Resistors. R = 30K $\pm 5\%$. Each Resistor = $\pm 5\%$ Total $\pm 0.5\%$. To Troubleshoot R2 use Table I, Voltages Measured at TP9 For Frequency Settings Shown.

N2 LEAD DESIGNATION & DESTINATION

A14 Pin	DEST.	A14 Pin	DEST.	Schematic Dest.
B	F800K XA5A-P	5	F10K XA5A-10	5
C	F400K XA5A-N	V	N2 RF XA13-H	5
D	F200K XA5A-M	R	N2 SL2 RF XA21-C	8
E	F100K XA5A-L	N	N2 ERR XA13-V	3
2	F80K XA5A-13	M	N2 TUNE XA22-C	9
3	F40K XA5A-12	M	XA25-B	11
4	F20K XA5A-11			

Schematic No. 28 is diagram of A5.

Figure 7-9. N3 VTO A12, N2 VTO A14.
7-29/7-30

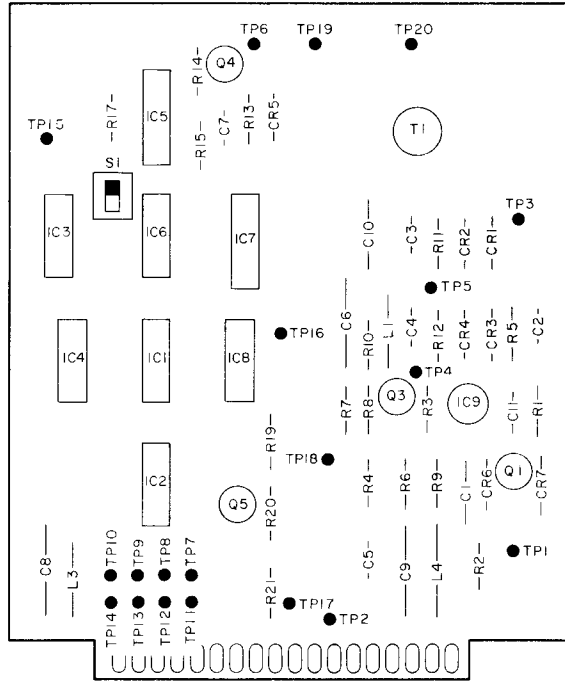

3350A-B-2785

A9, A11, A13
 hp Part No. 03330-66510

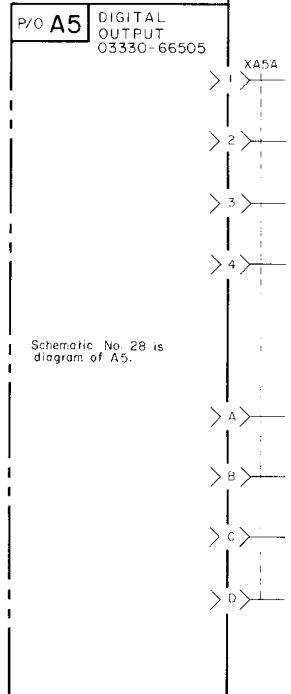

Schematic No. 28 is diagram of A5.

COPYRIGHT 1972 BY HEWLETT-PA

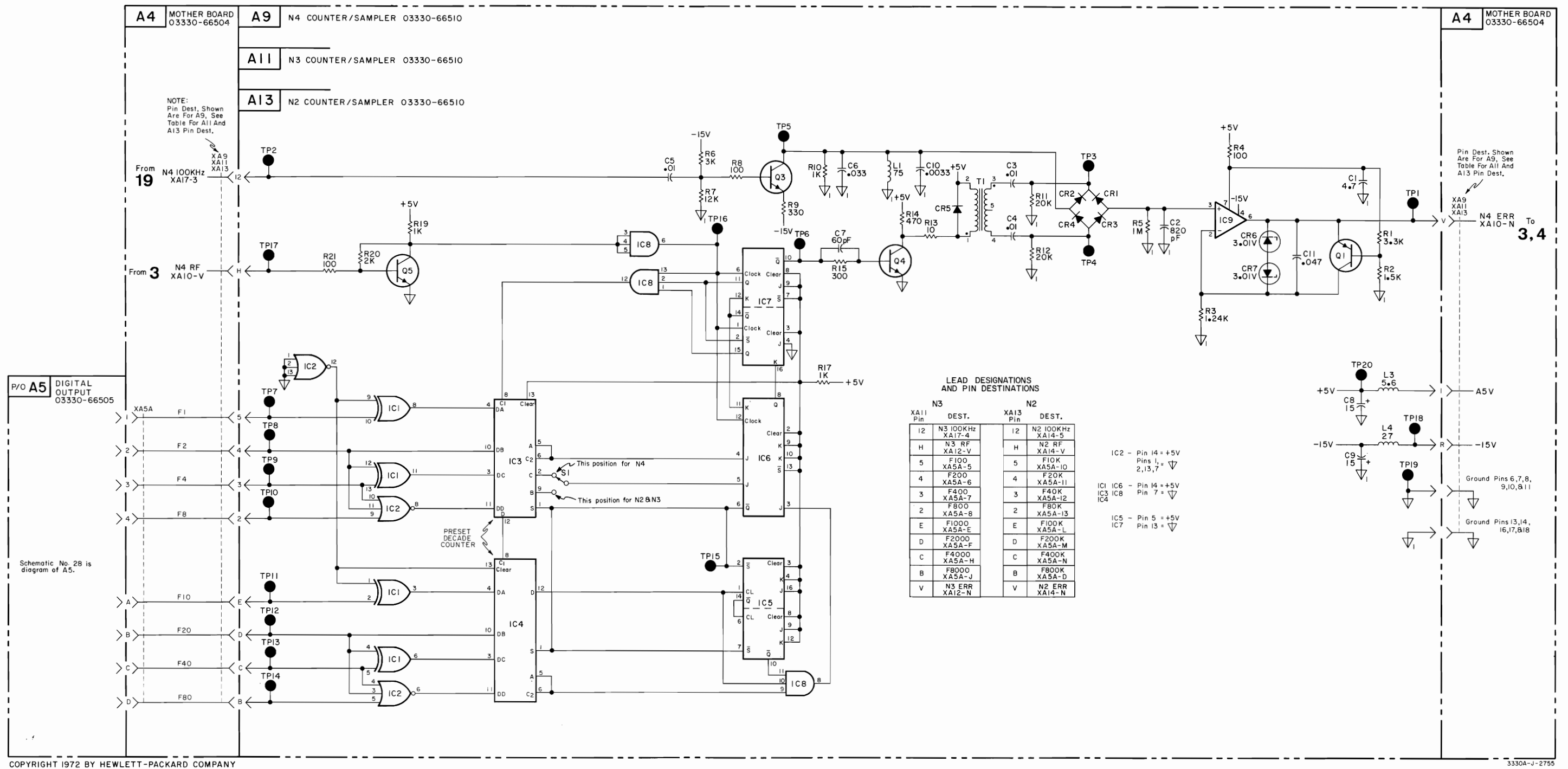
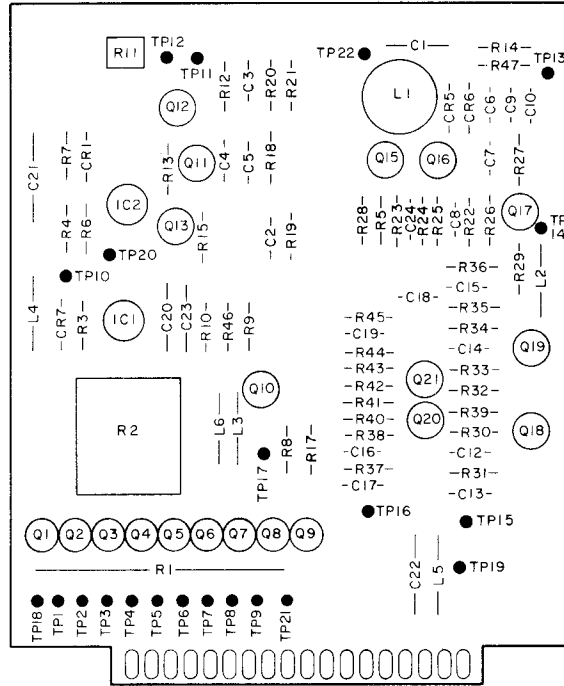

Figure 7-10. N4 Counter/Sampler A9, N3 Counter/Sampler A11, N2 Counter/Sampler A13.



3330A-B-2785

A16

hp Part No. 03330-66512

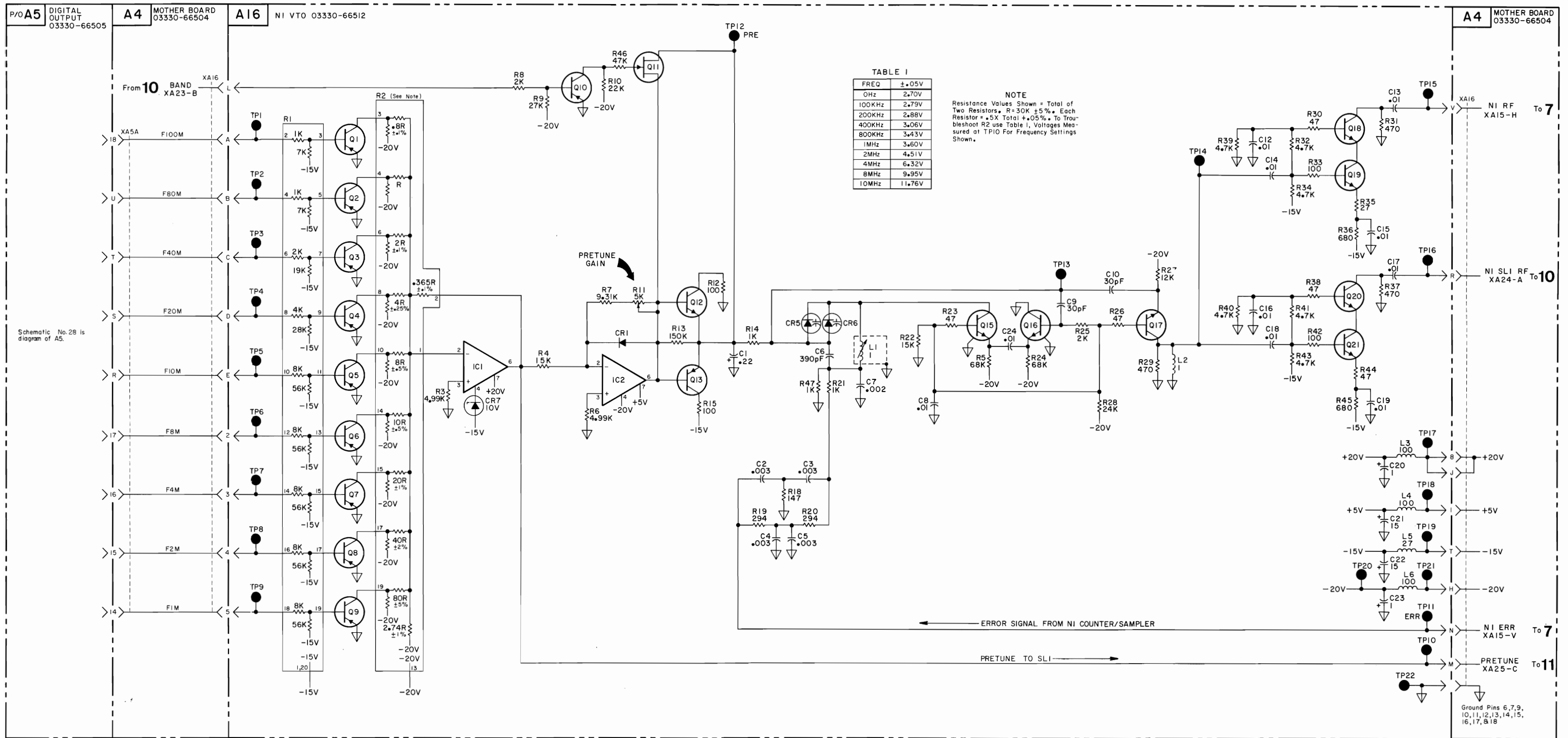

TABLE I

FREQ	±.05V
0Hz	2.70V
100KHz	2.79V
200KHz	2.88V
400KHz	3.06V
800KHz	3.43V
1MHz	3.60V
2MHz	4.51V
4MHz	6.32V
8MHz	9.95V
10MHz	11.76V

NOTE
Resistance Values Shown = Total of Two Resistors. R = 30K ± 5%. Each Resistor = .5X Total ± .05%. To Troubleshoot R2 use Table I, Voltages Measured at TP10 For Frequency Settings Shown.

Schematic No. 28 is diagram of A5.

Ground Pins 6, 7, 9, 10, 11, 12, 13, 14, 15, 16, 17, & 18

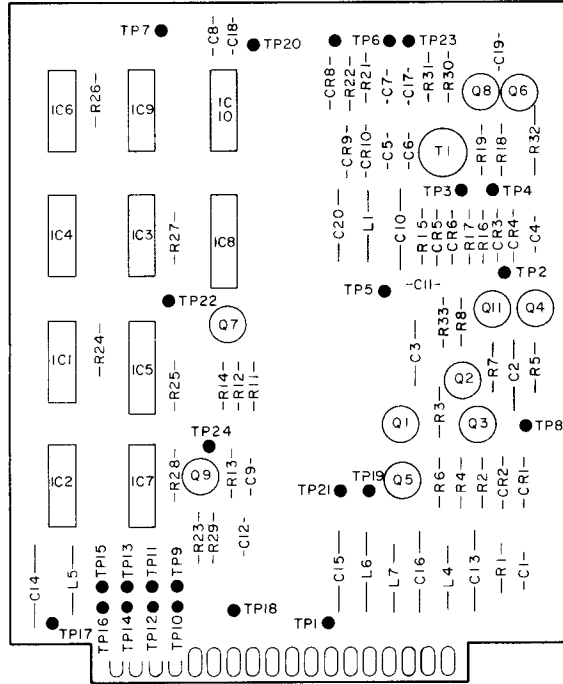

3330A-B-2786

A15

hp Part No. 03330-66513

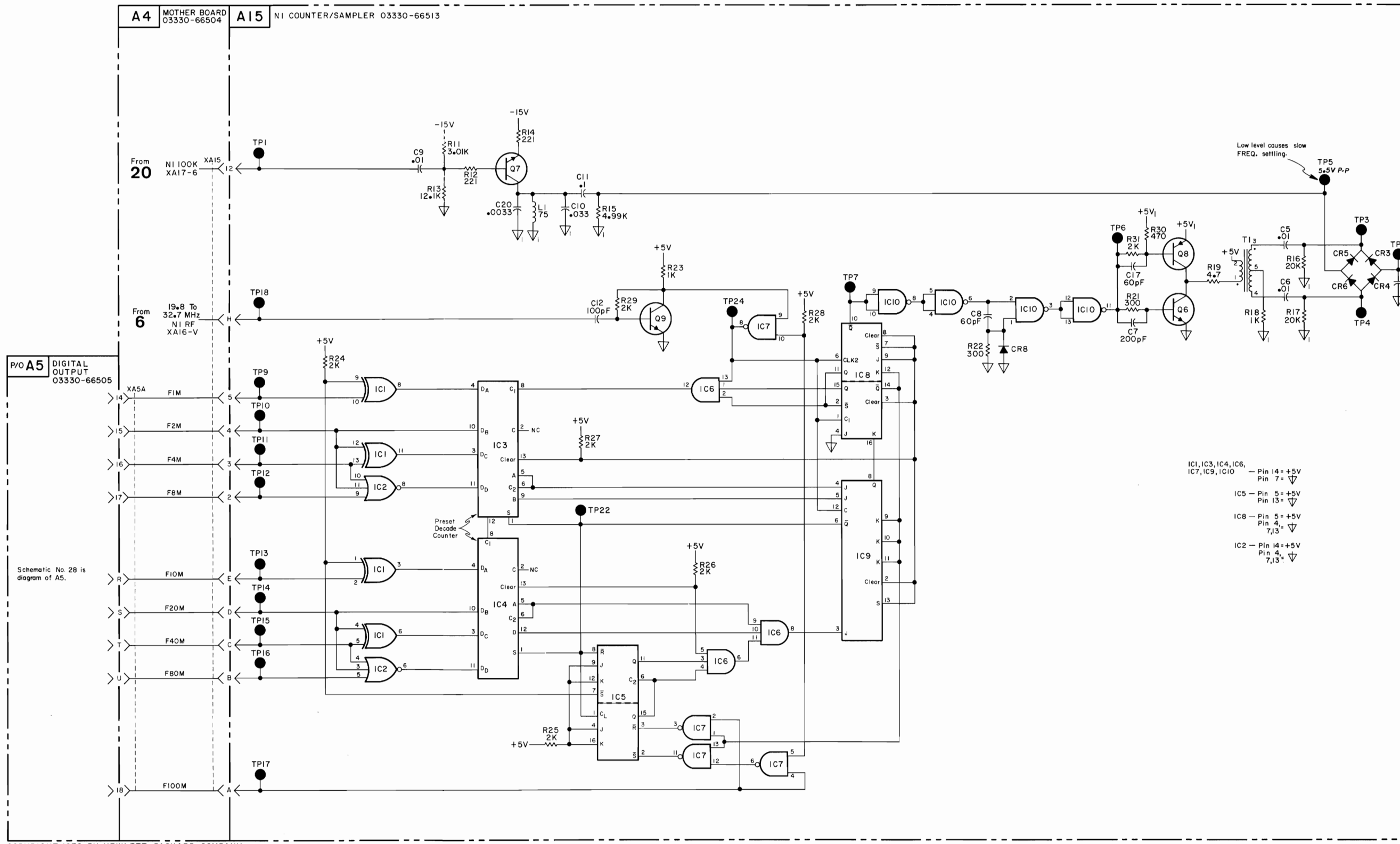

Schematic No. 28 is diagram of A5.

- IC1, IC3, IC4, IC6, IC7, IC9, IC10 - Pin 14 = +5V
Pin 7 = ∇
- IC5 - Pin 5 = +5V
Pin 13 = ∇
- IC8 - Pin 5 = +5V
Pin 4, 7, 13 = ∇
- IC2 - Pin 14 = +5V
Pin 4, 7, 13 = ∇

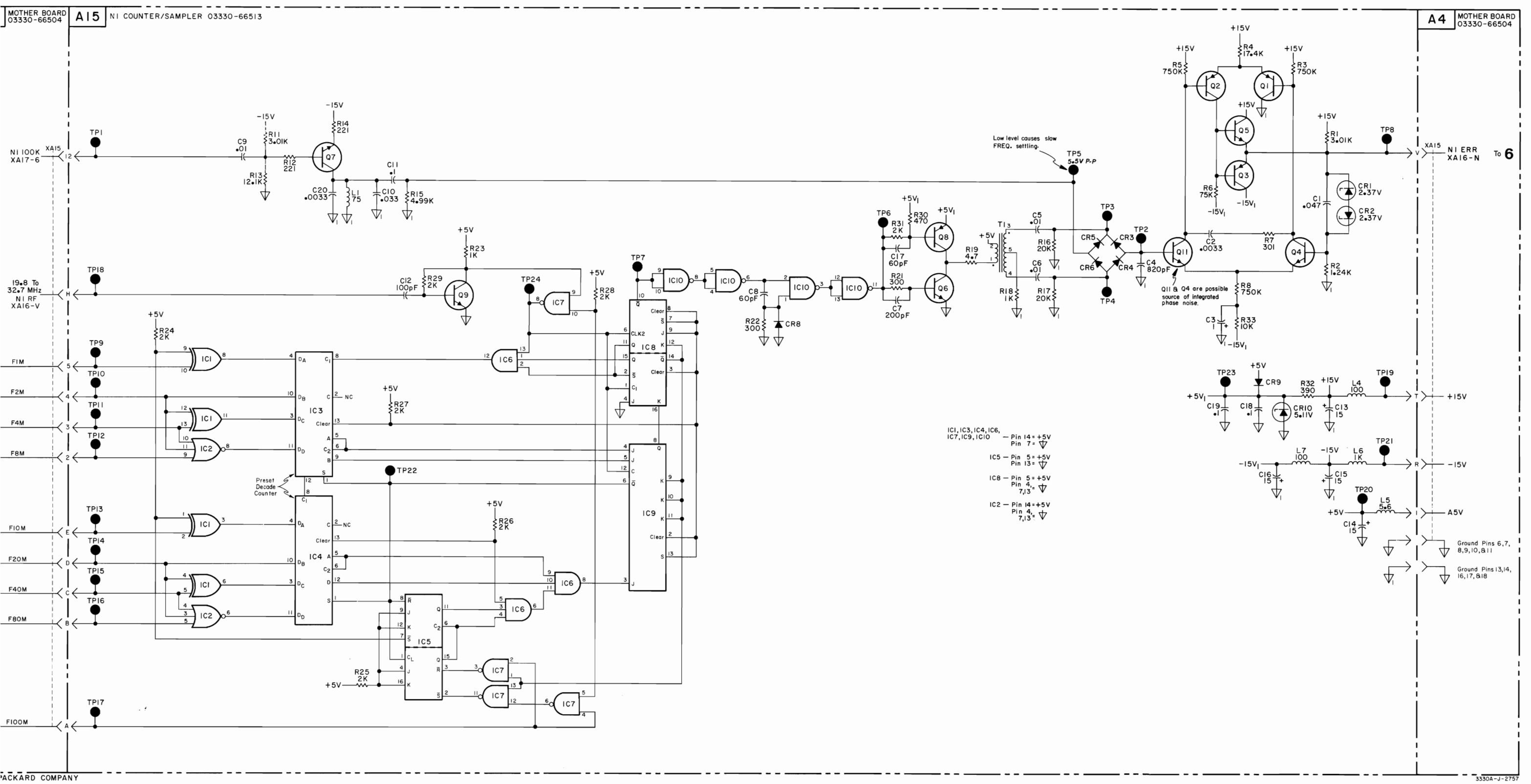
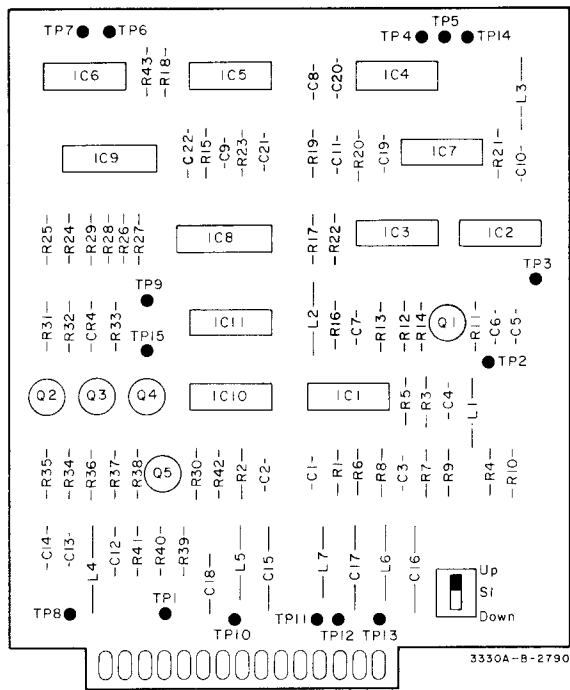
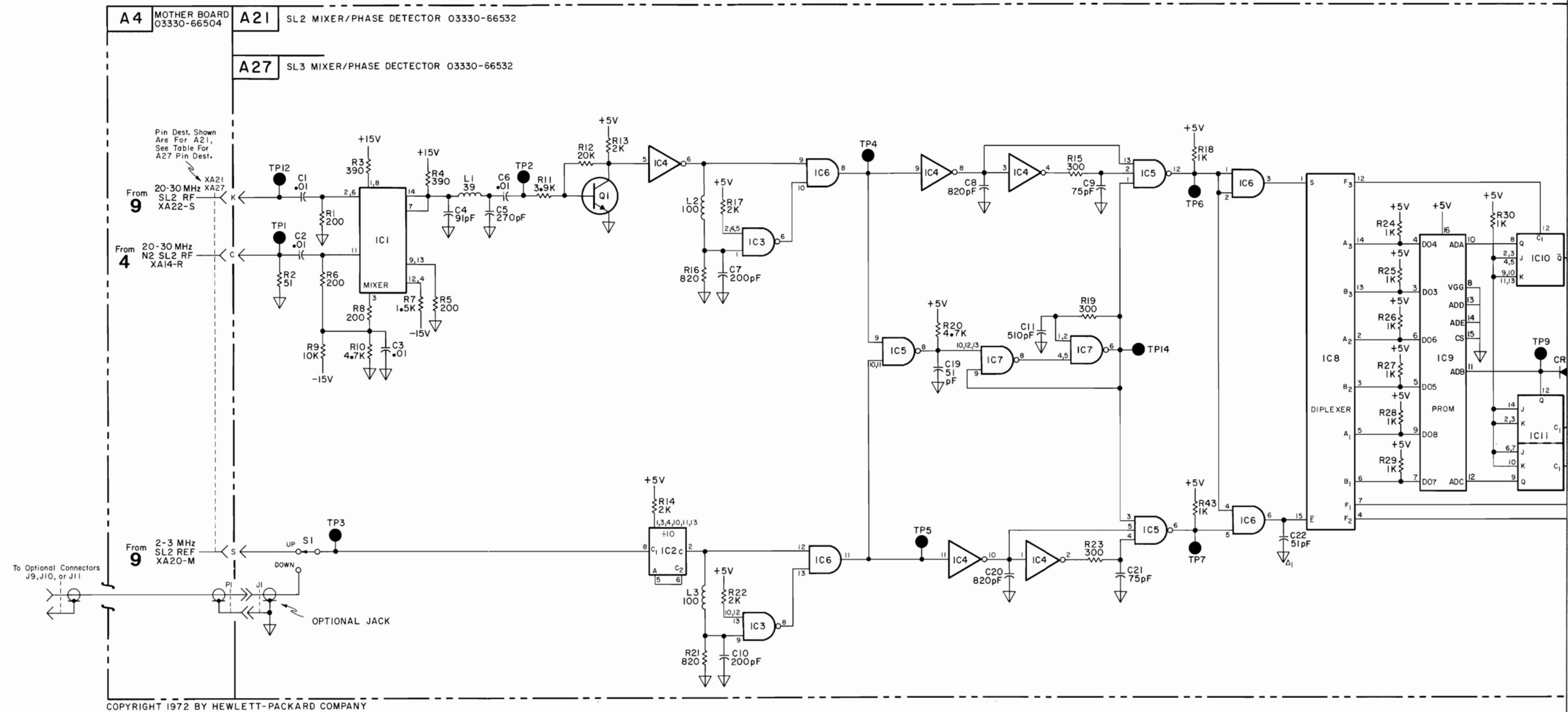

Figure 7-12. NI Counter/Sampler A15.
7-35/7-36



A21, A27

hp Part No. 03330-66532
Rev. B



COPYRIGHT 1972 BY HEWLETT-PACKARD COMPANY

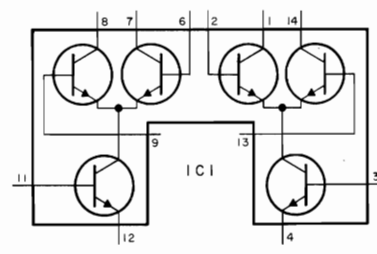

XA27 Pin	DEST.	Schematic No.
K	SL3 RF XA20-S	9
C	N3 SL3 RF XA12-R	4
S	SL3 REF XA10-R	3
A	SL3 ERR XA20-A	9

IC2 Thru IC7 & IC10
 Pin 14 = +5V
 Pin 7 = ∇

IC8 & IC9
 Pin 16 = +5V
 Pin 8 = ∇

IC11
 Pin 11 = +5V
 Pin 4 = ∇

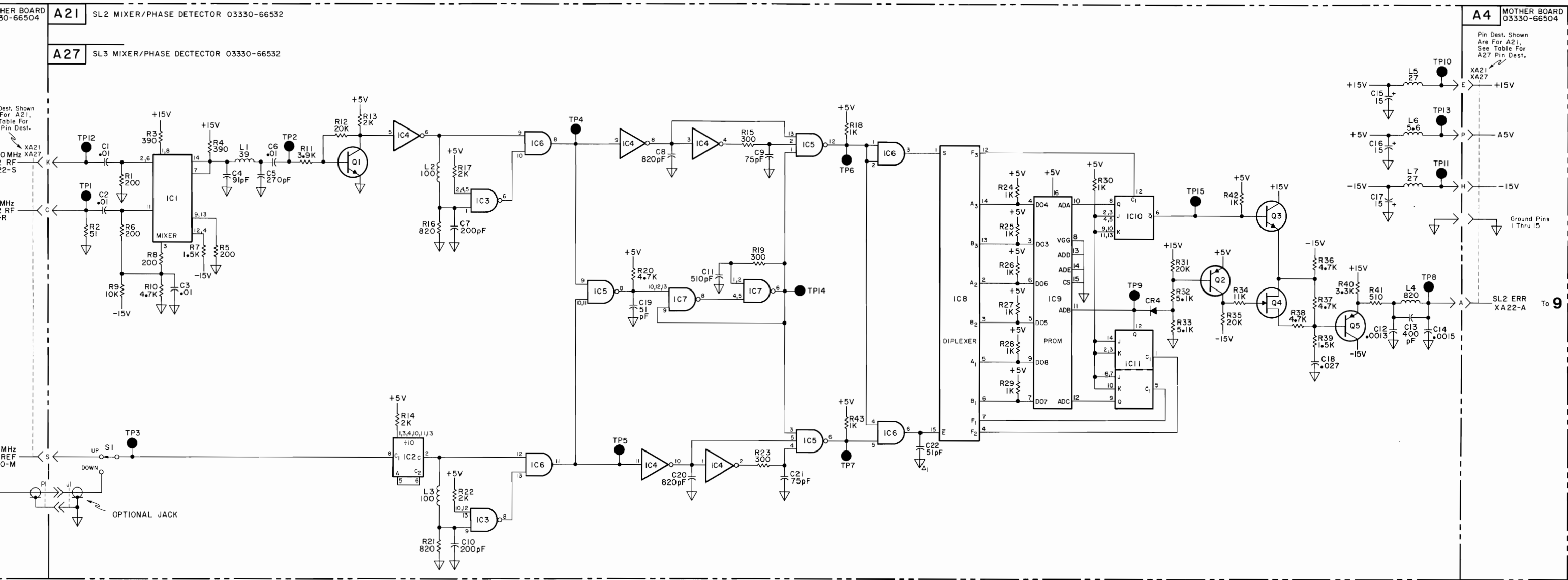

72 BY HEWLETT-PACKARD COMPANY 3330A-J-2758

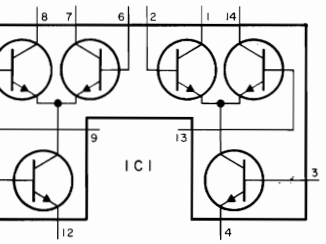

XA27 Pin	DEST.	Schematic No.
K	SL3 RF XA20-S	9
C	N3 SL3 RF XA12-R	4
S	SL3 REF XA10-R	3
A	SL3 ERR XA20-A	9

IC2 Thru IC7 & IC10 Pin 14 = +5V
 Pin 7 = ∇
 IC8 & IC9 Pin 16 = +5V
 Pin 8 = ∇
 IC11 Pin 11 = +5V
 Pin 4 = ∇

Figure 7-13. SL2 Mixer/Phase Detector A21
 SL3 Mixer/Phase Detector A27.
 7-37/7-38

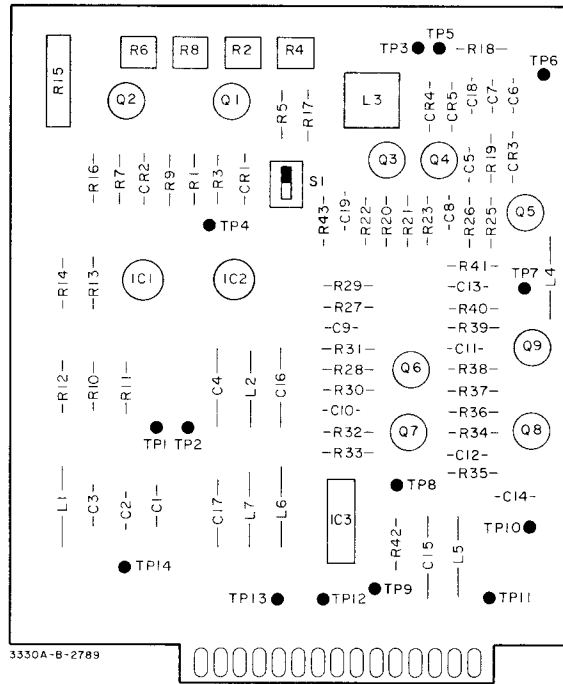

A20, A22
hp Part No. 03330-66517

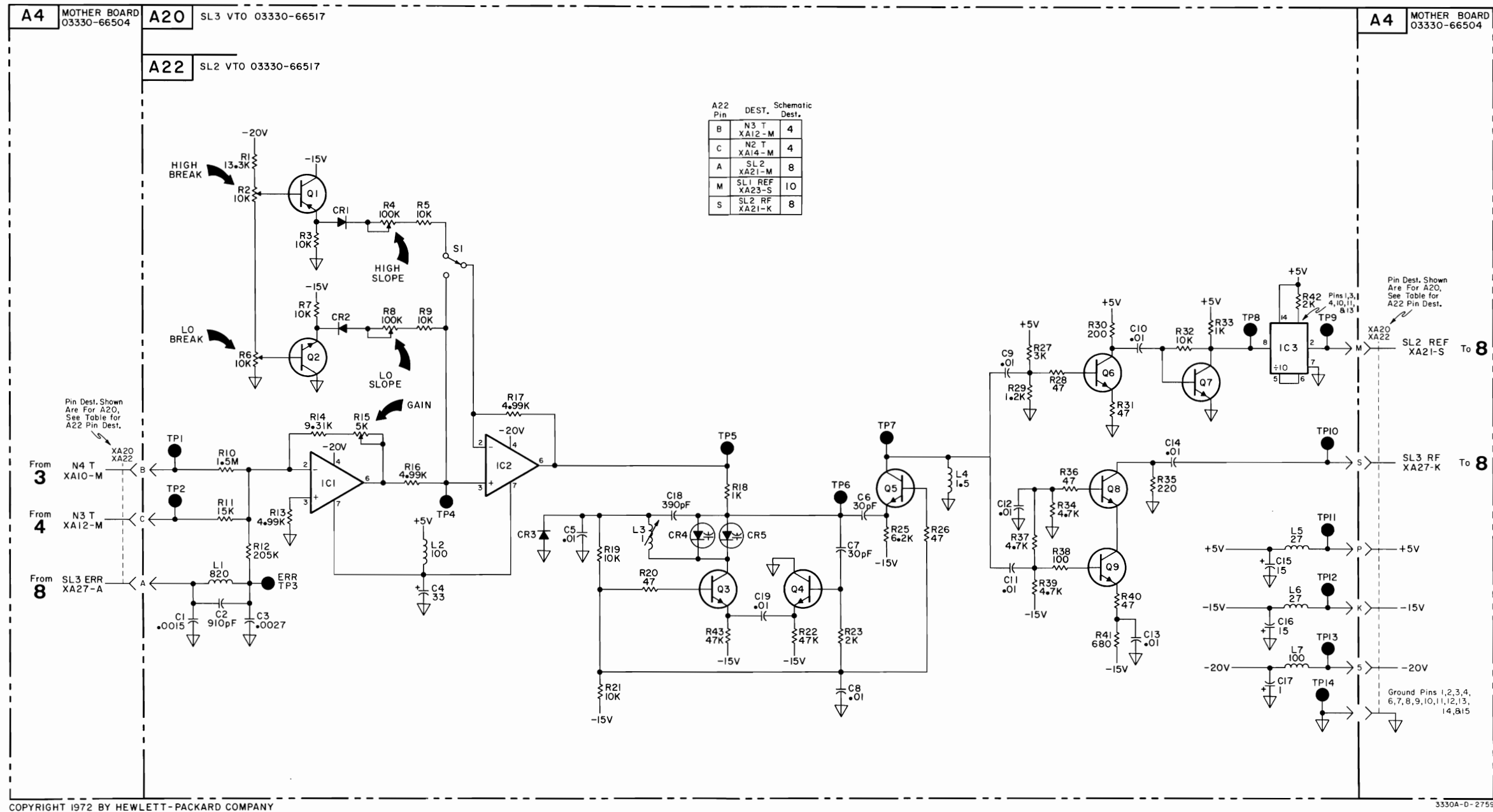

COPYRIGHT 1972 BY HEWLETT-PACKARD COMPANY

3330A-D-2759

Figure 7-14. SL3 VTO A20, SL2 VTO A22.

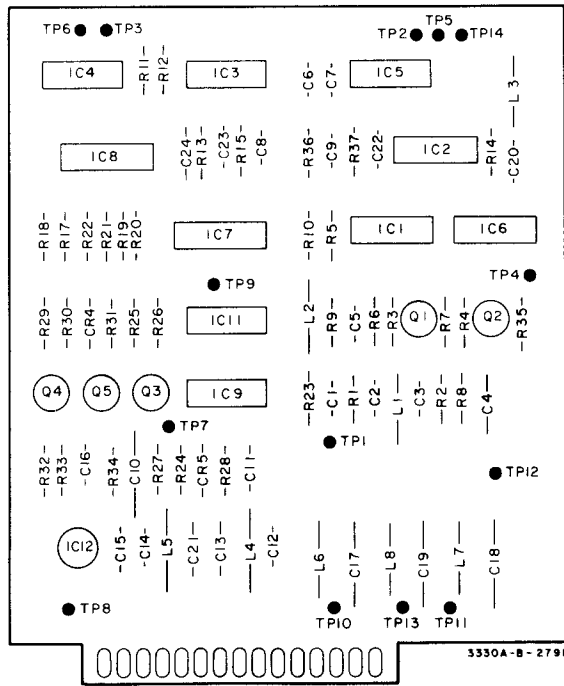

A23
hp Part No 03330-66533
Rev. B

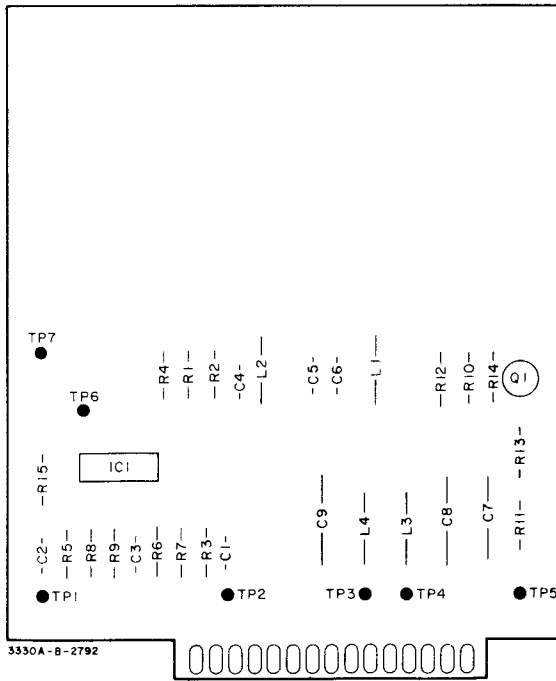

A24
hp Part No 03330-66520

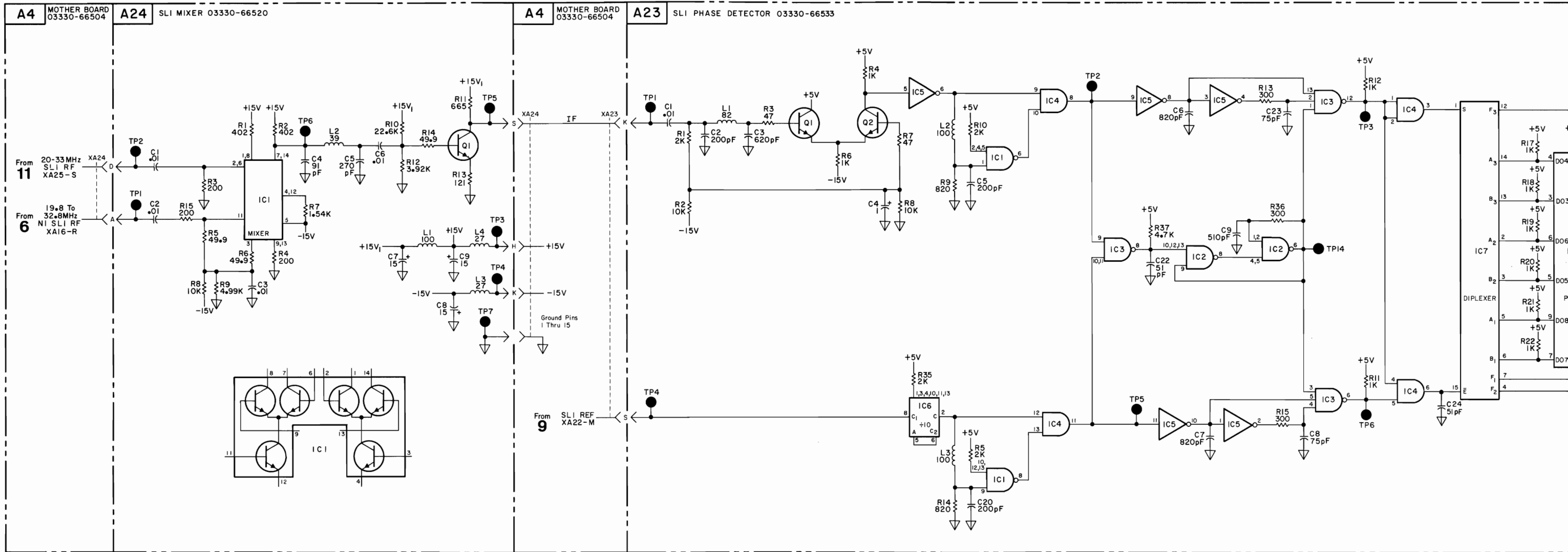

COPYRIGHT 1972 BY HEWLETT-PACKARD COMPANY

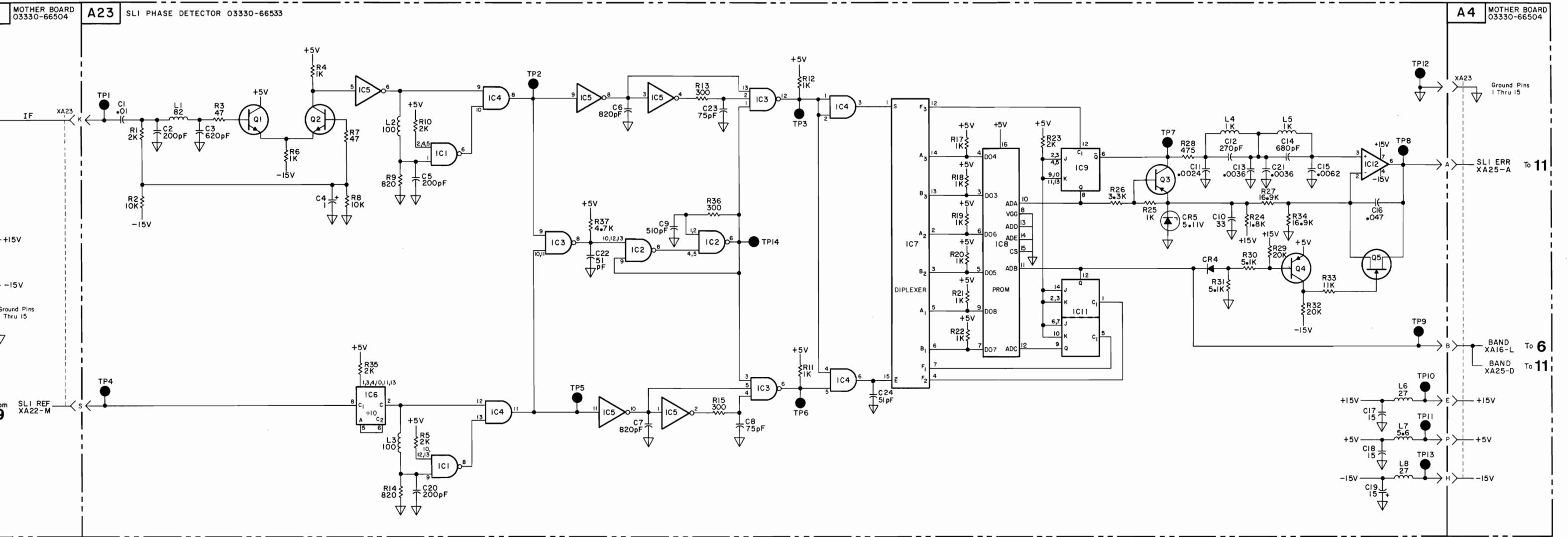

3330A-J-2760

Figure 7-15. SL1 Phase Detector A23, SL1 Mixer A24.
7-41/7-42

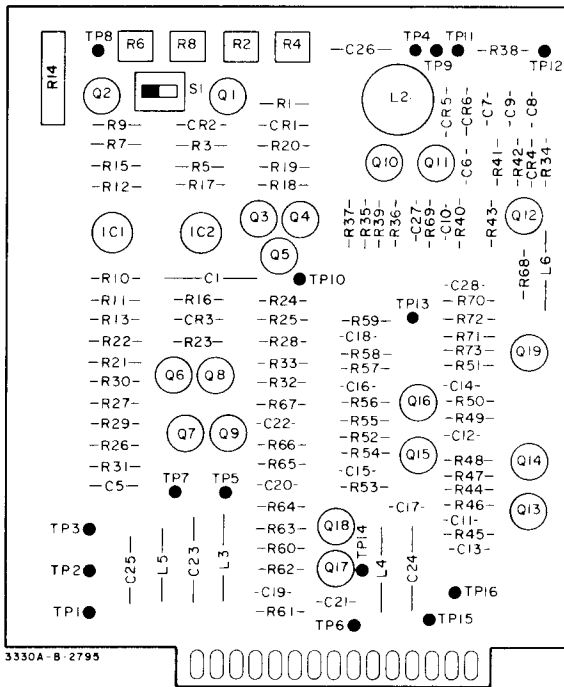

A25

hp Part No 03330-66521

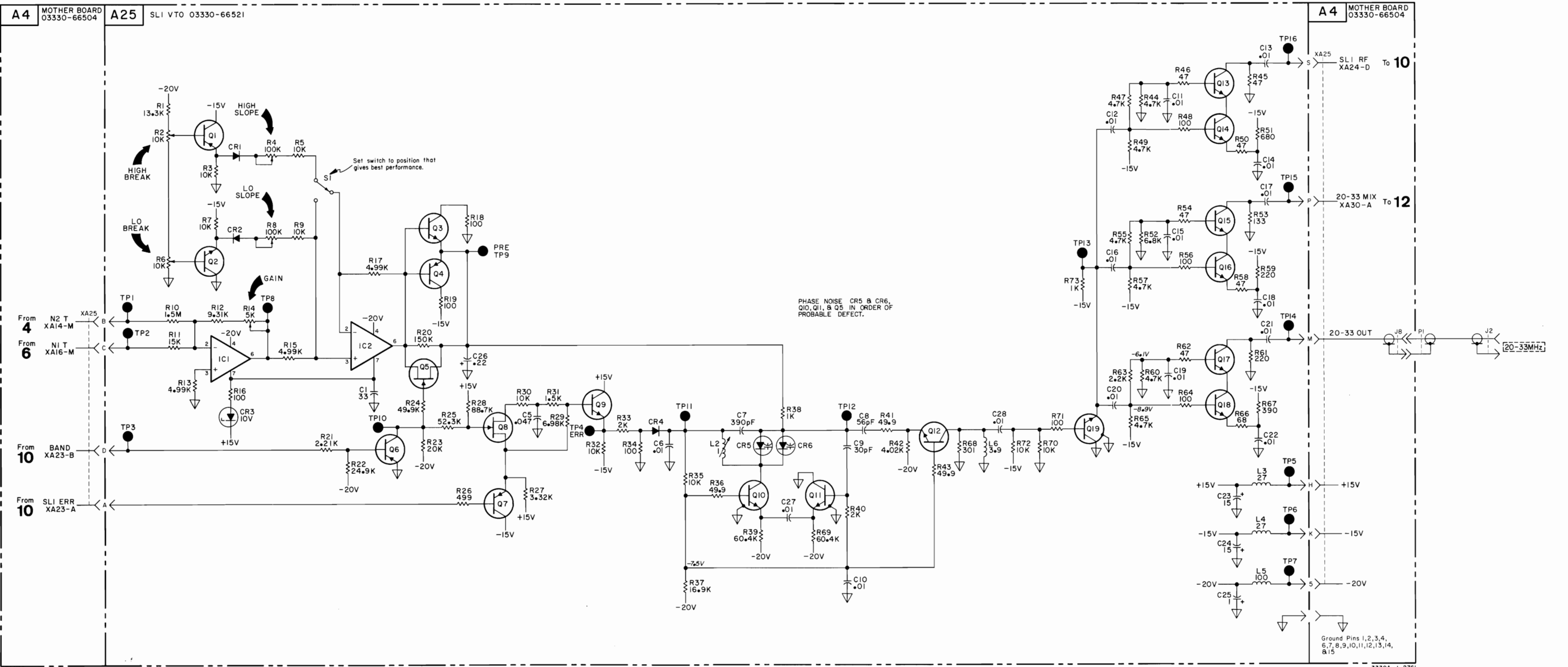

COPYRIGHT 1972 BY HEWLETT - PACKARD COMPANY

3330A-J-2761

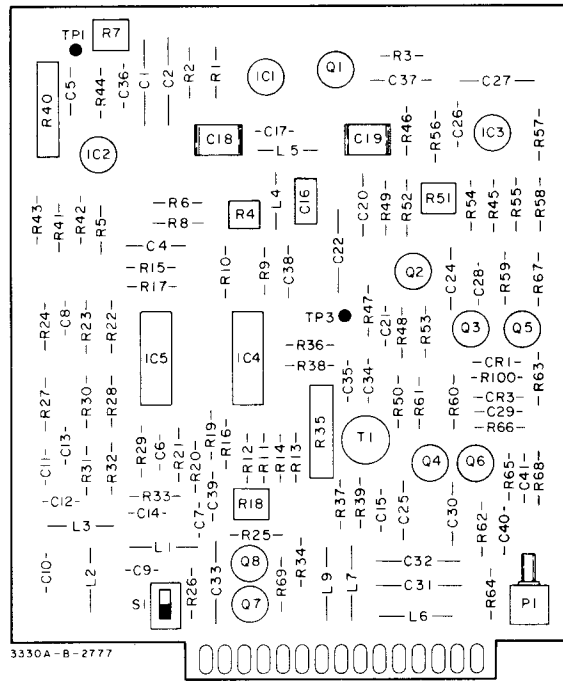

A30

hp Part No. 03330-66525

Rev. B

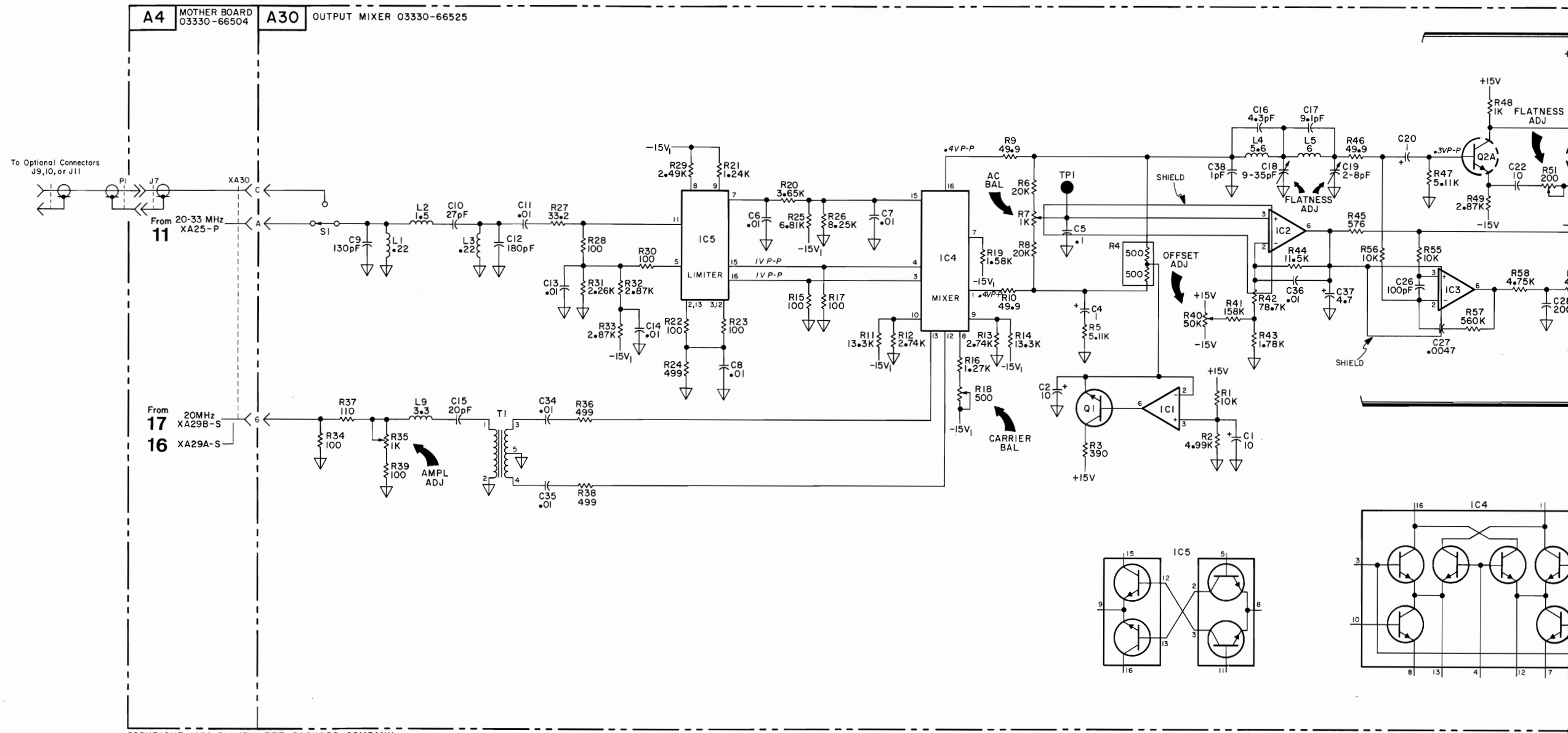

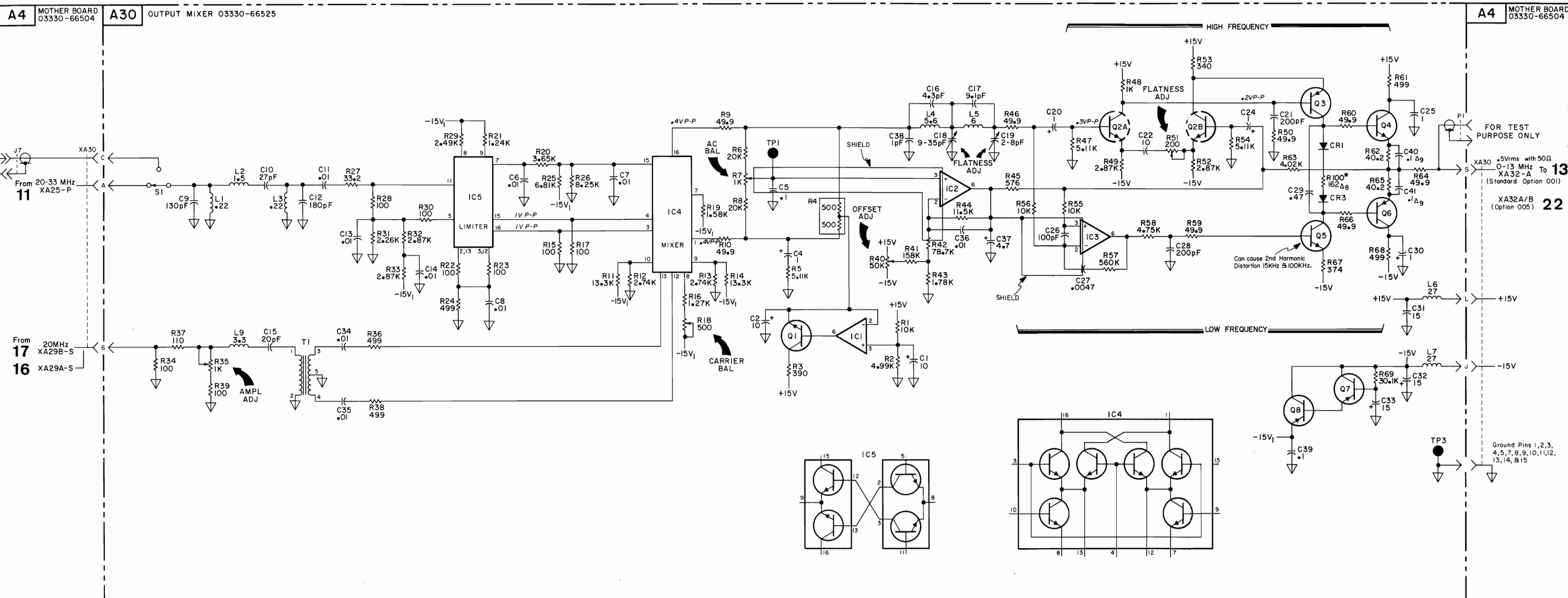
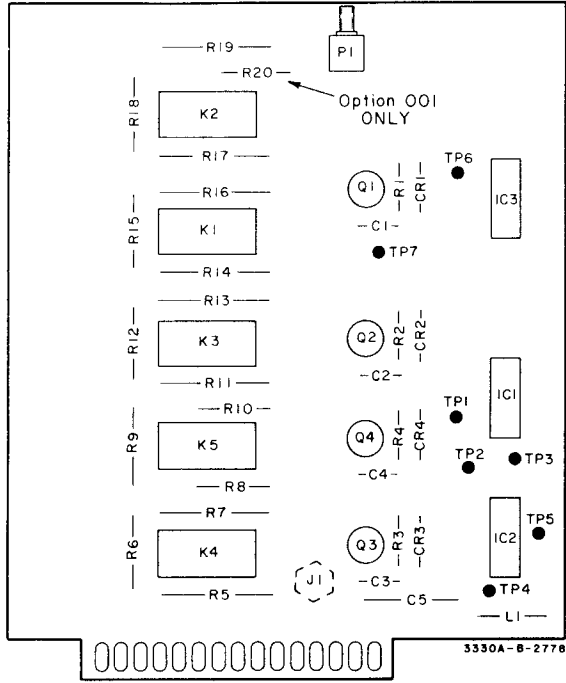

Figure 7-17. Output Mixer A30.
7-45/7-46



A31

hp Part No. 03330-66526

"OPTION 001"

hp Part No. 03330-66570

NOTE

SEE SCHEMATIC NO. 24 OR 25 FOR AMPLITUDE CONSTANT SELECTION.

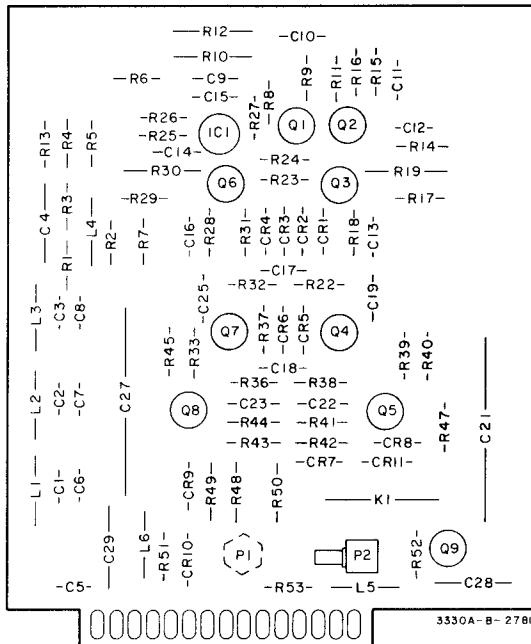

A32B

hp Part No. 03330-66527

A32A

hp Part No. 03330-66572

Delete R50, R52, R53, CR11, Q9, & K1

"OPTION 001"

hp Part No. 03330-66571

Change R48 and R49 From 100Ω to 150Ω

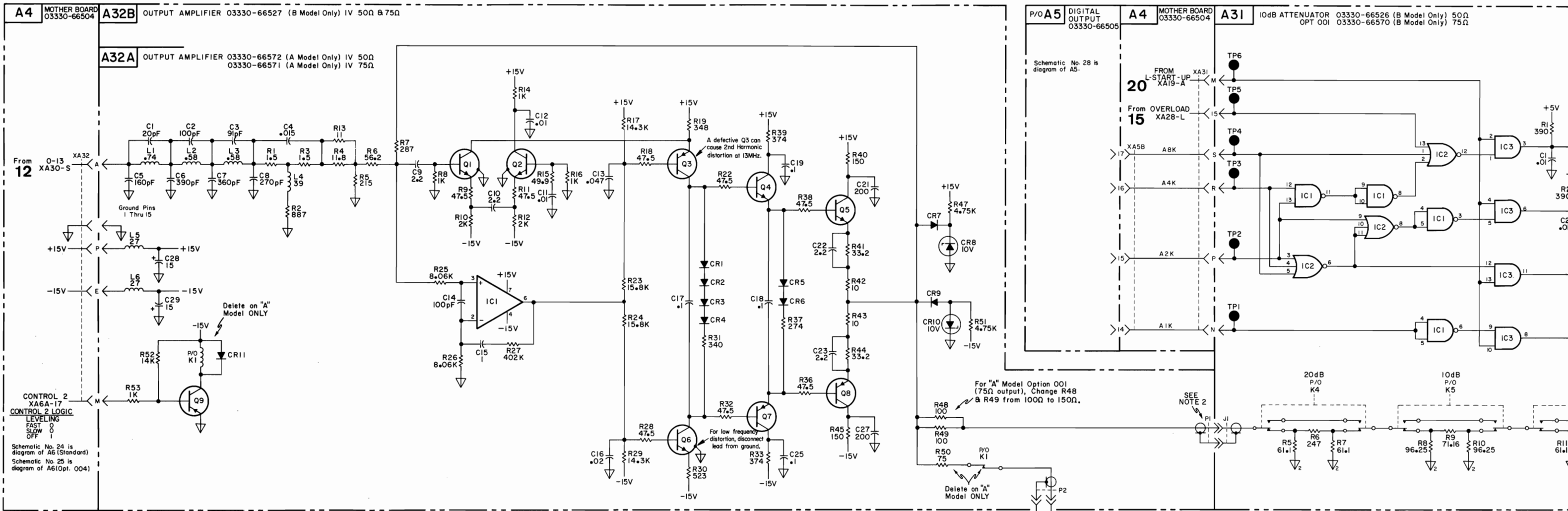

COPYRIGHT 1972 BY HEWLETT-PACKARD COMPANY

NOTE 2:
For "A" model A32A P/O connects directly to panel OUTPUT or red panel ALT OUTPUT.

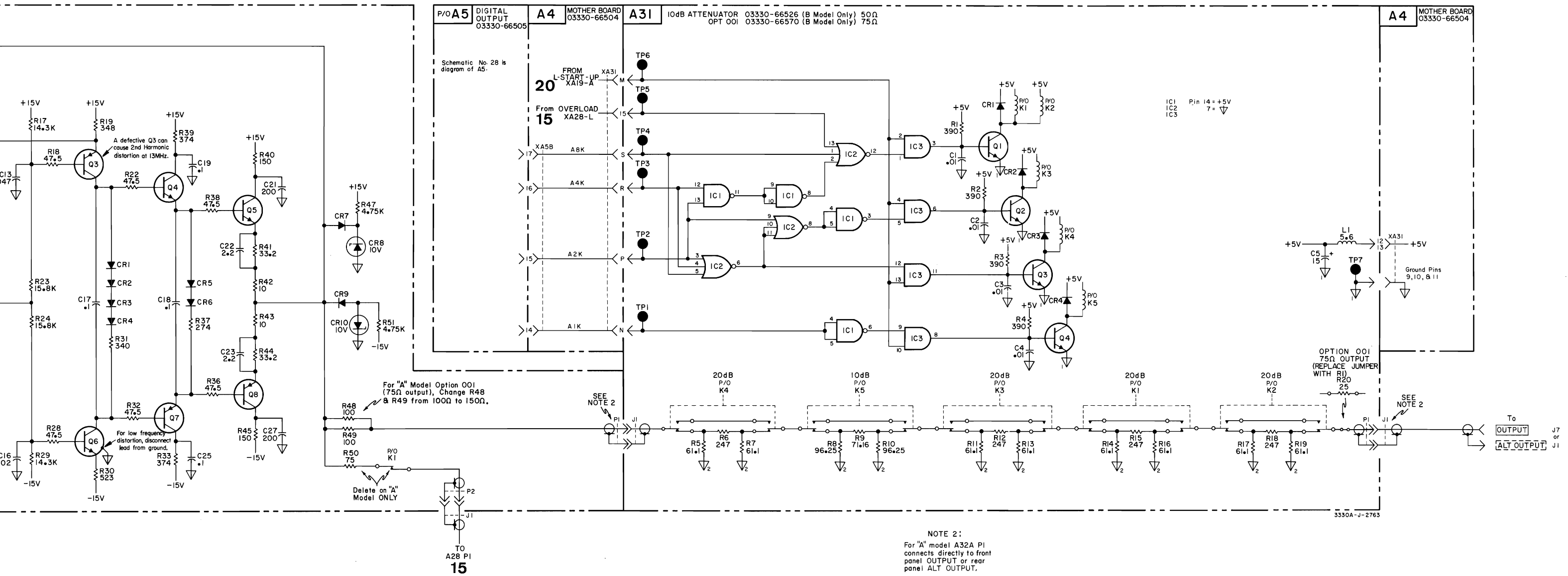
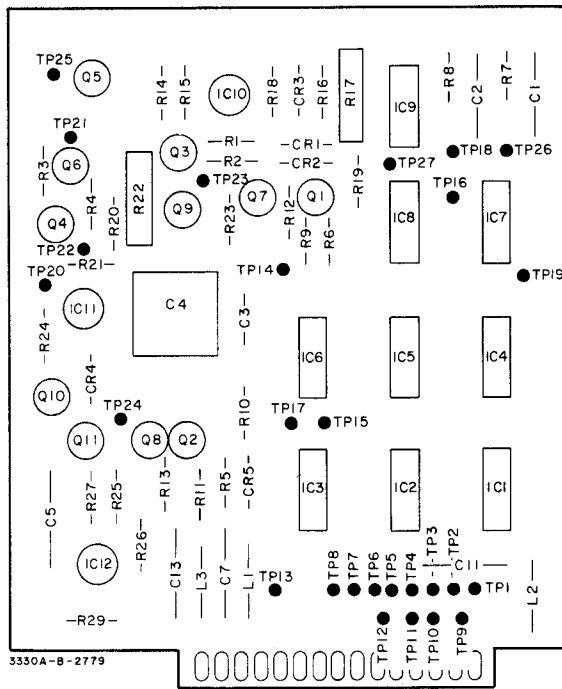

Figure 7-18. Attenuator A31 (standard, 75 Ω) Output Amplifier A32A (standard, 75 Ω) Output Amplifier A32B. 7-47/7-48



A26

hp Part No. 03330-66522

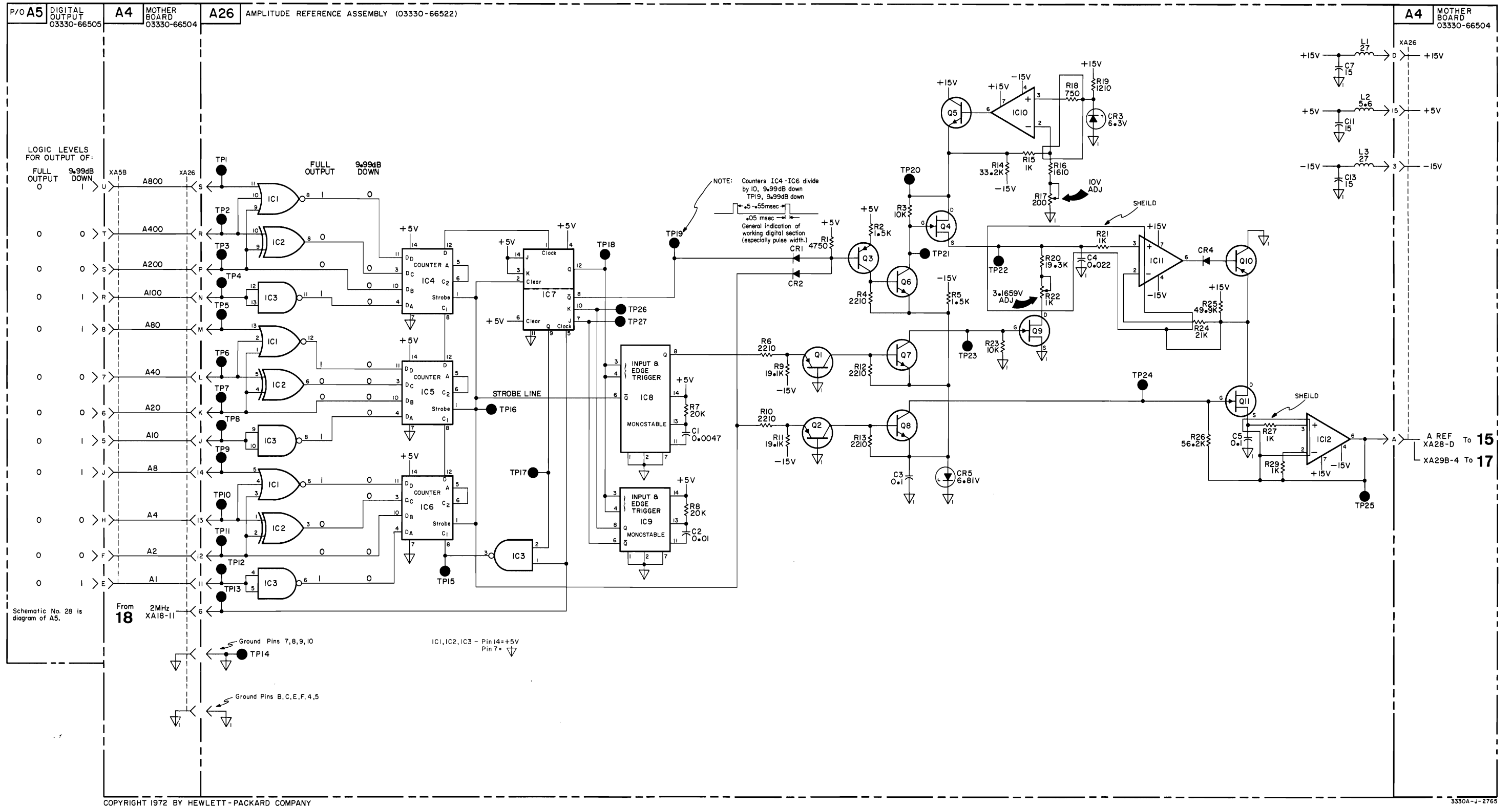
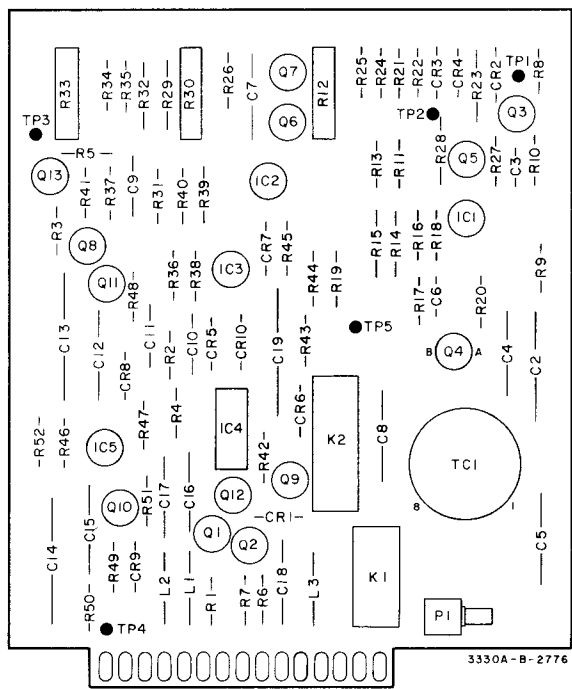

Figure 7-19. Amplitude Reference A26. 7-49/7-50



A28

hp Part No. 03330-66523

NOTE 1

- 03330-66576 (3330B STANDARD)
- 03330-66577 (3330B OPTION 004)
- 03330-66578 (3330A STANDARD)
- 03330-66579 (3330A OPTION 004)

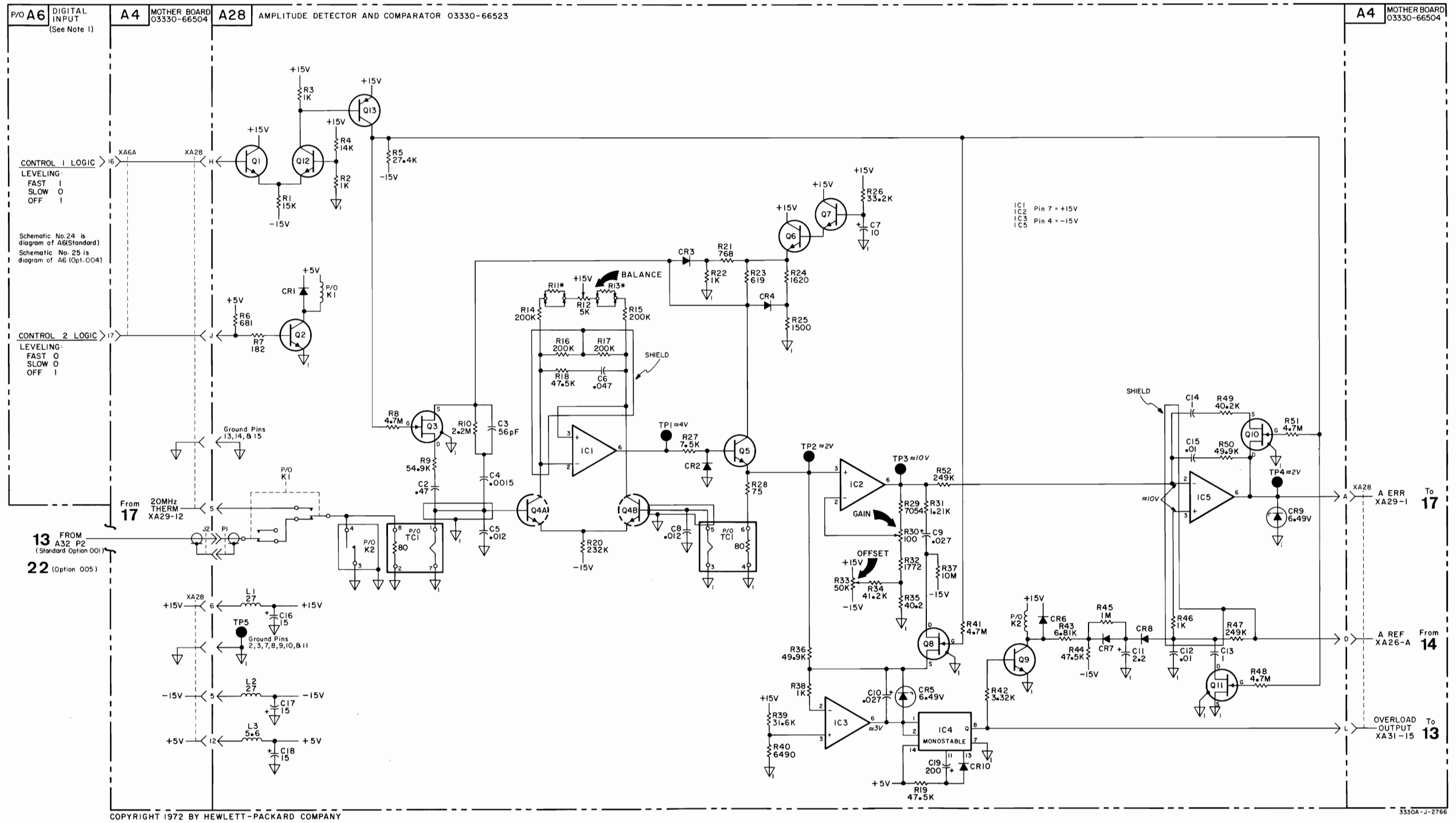
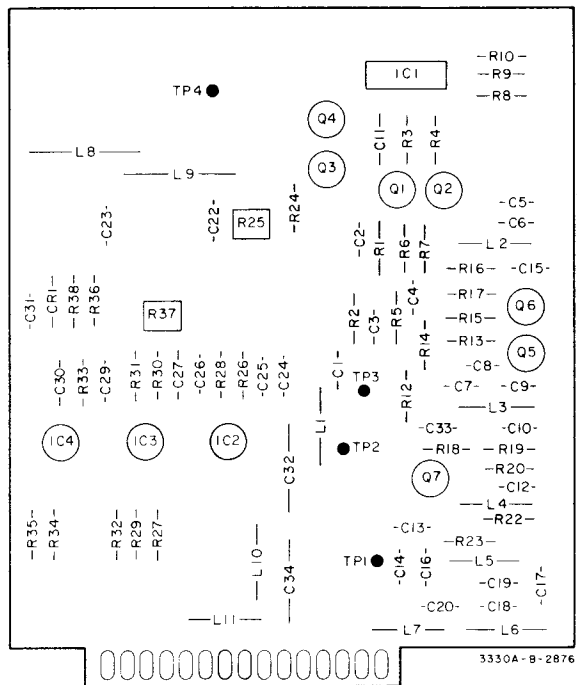
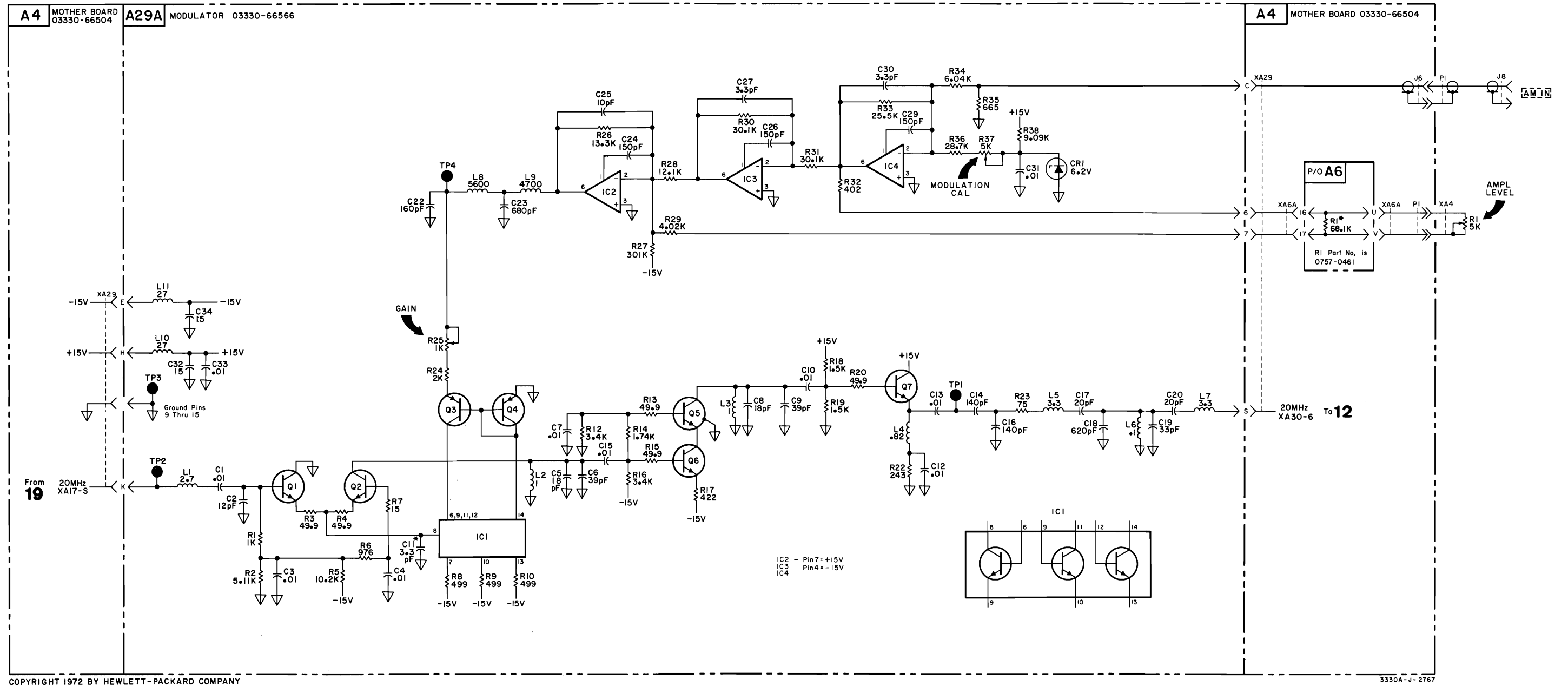

Figure 7-20. Amplitude Detector/Comparator A28.
7-51/7-52



A29A

hp Part No. 03330-66566



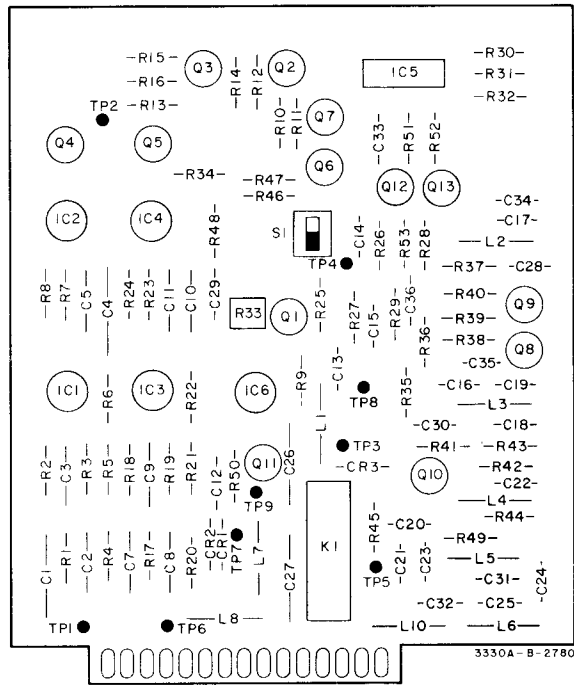

A29B

hp Part No. 03330-66524

NOTE 1

- 03330-66576 (3330B STANDARD)
- 03330-66577 (3330B OPTION 004)
- 03330-66578 (3330A STANDARD)
- 03330-66579 (3330A OPTION 004)

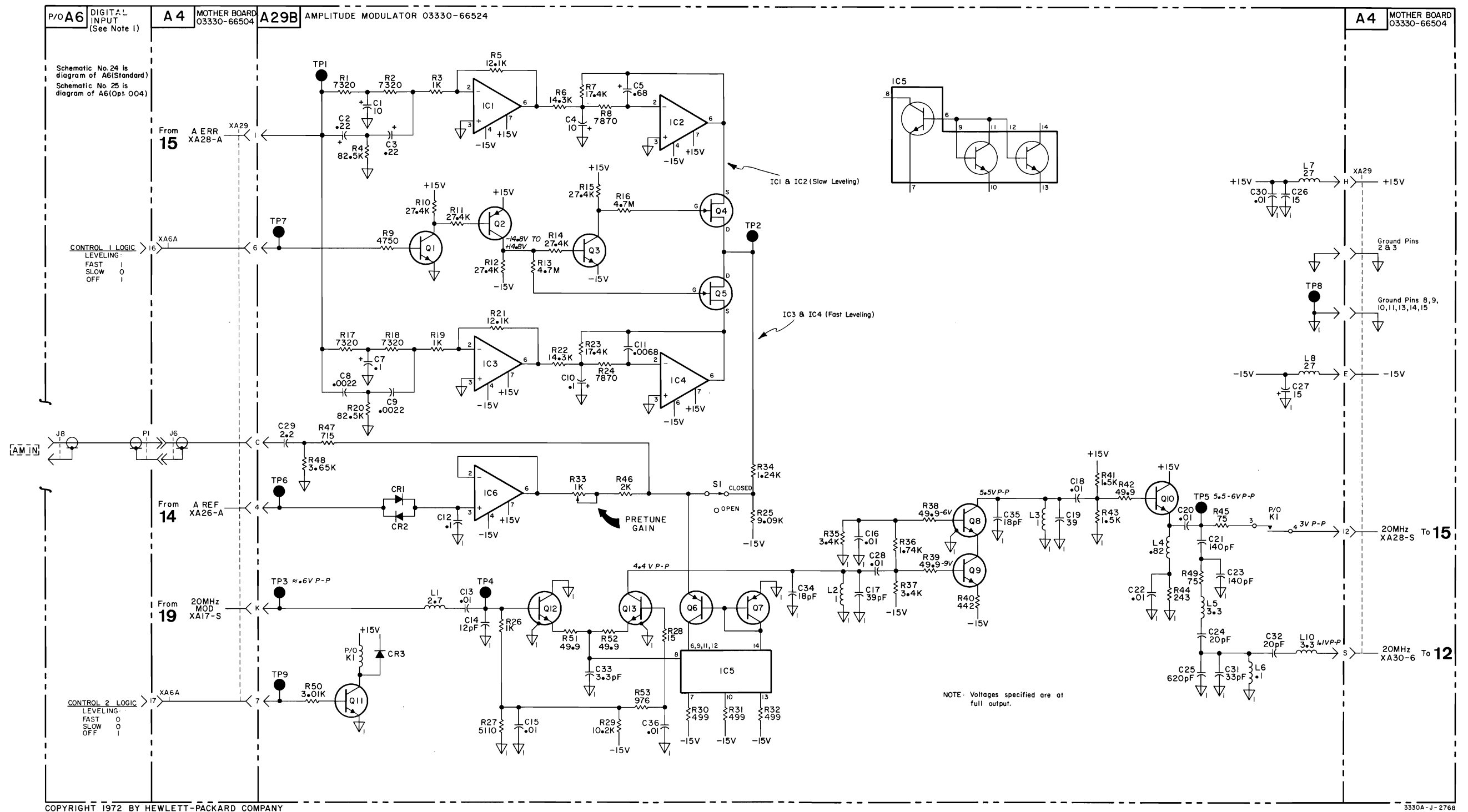
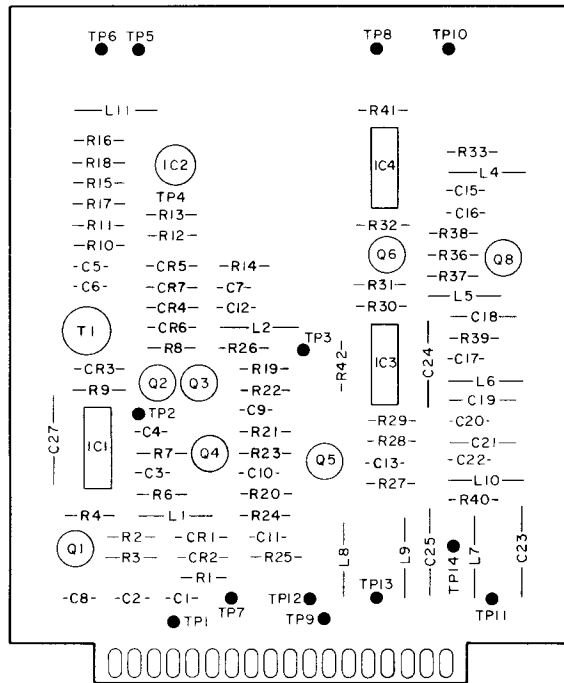

Figure 7-22. Amplitude Modulator A29B.
7-55/7-56



3330A-B-2788

A18

hp Part No. 03330-66515

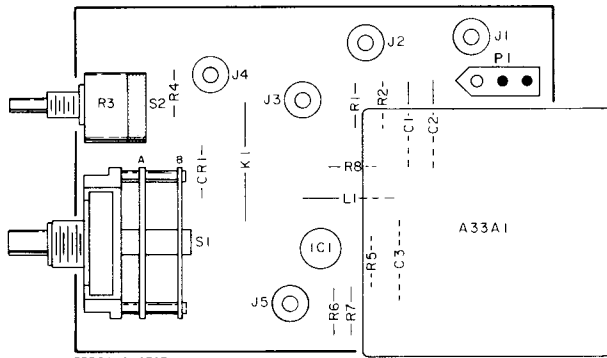

3330A-B-2797

A33

hp Part No 03330-66528

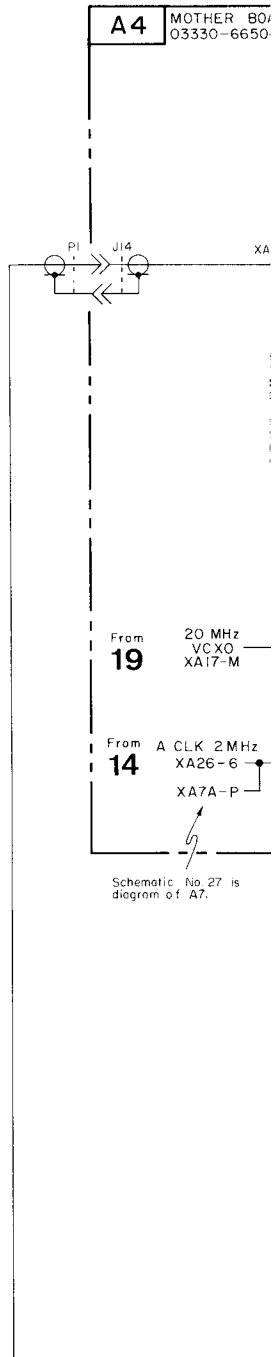

A4 MOTHER BO/ 03330-6650

From 19 20 MHz VCXO XA17-M

From 14 A CLK 2MHz XA26-6 XA7A-P

Schematic No. 27 is diagram of A7.

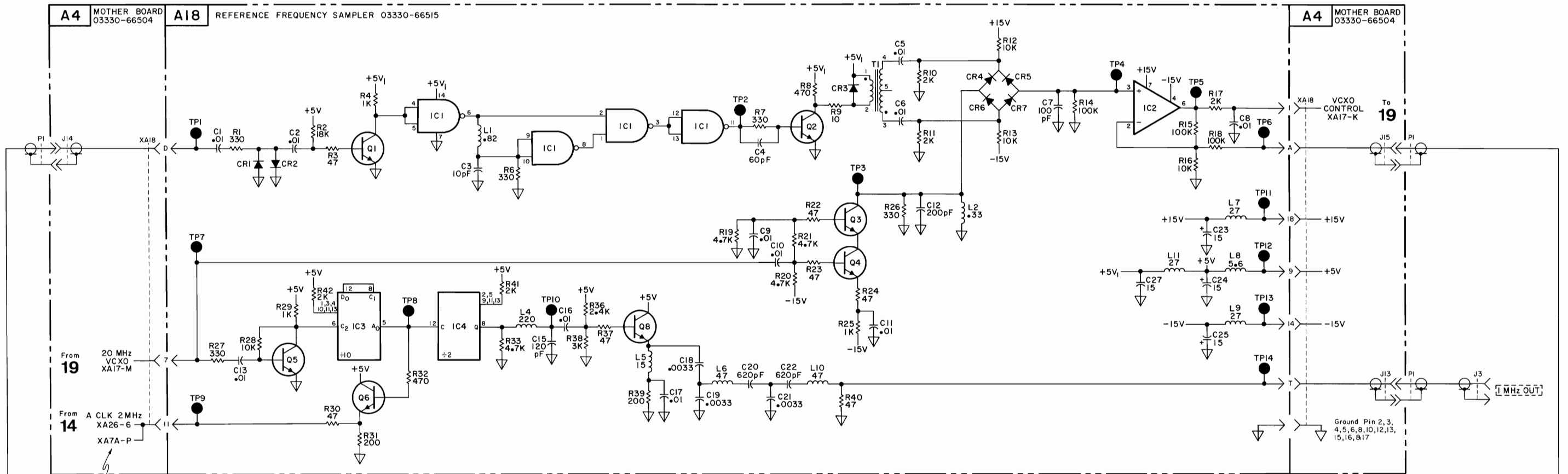

Schematic No. 27 is diagram of A7.

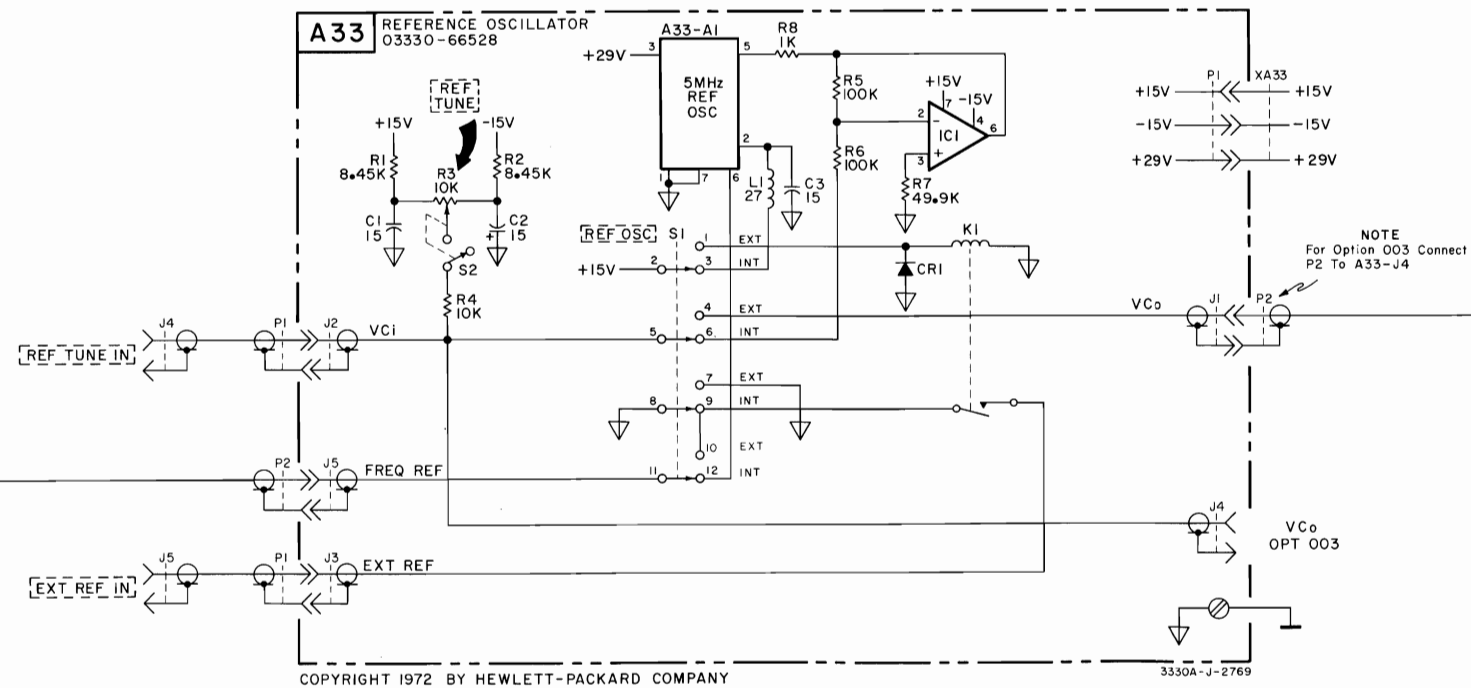

NOTE

THIS SCHEMATIC USED WITH ALL INSTRUMENTS NOT CONTAINING OPTION 002. SEE FOLLOWING SCHEMATIC OF FIGURE 7-24 FOR OPTION 002 INSTRUMENTS.

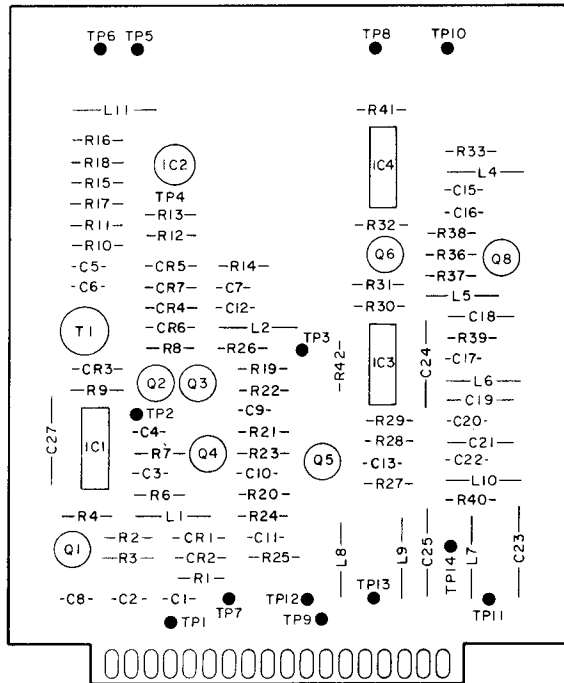

3330A-B-2788

A18

hp Part No. 03330-66515

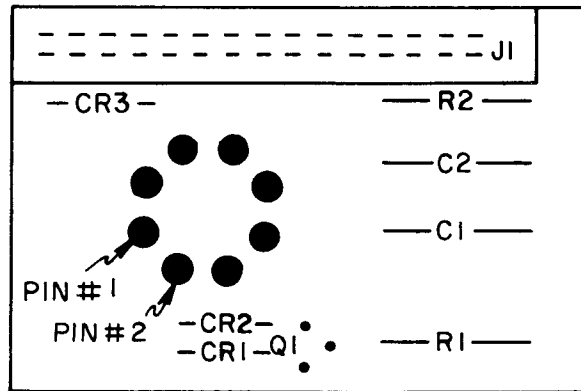

11452-66501

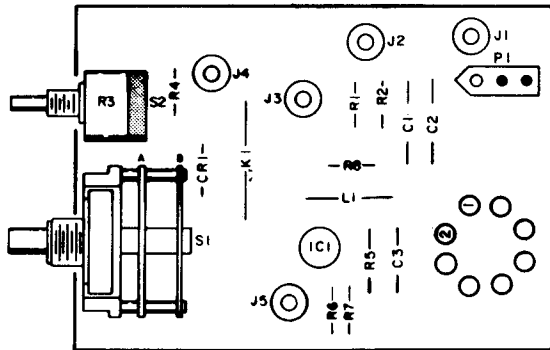

3330A-B3786

A33

hp Part No 03330-66528

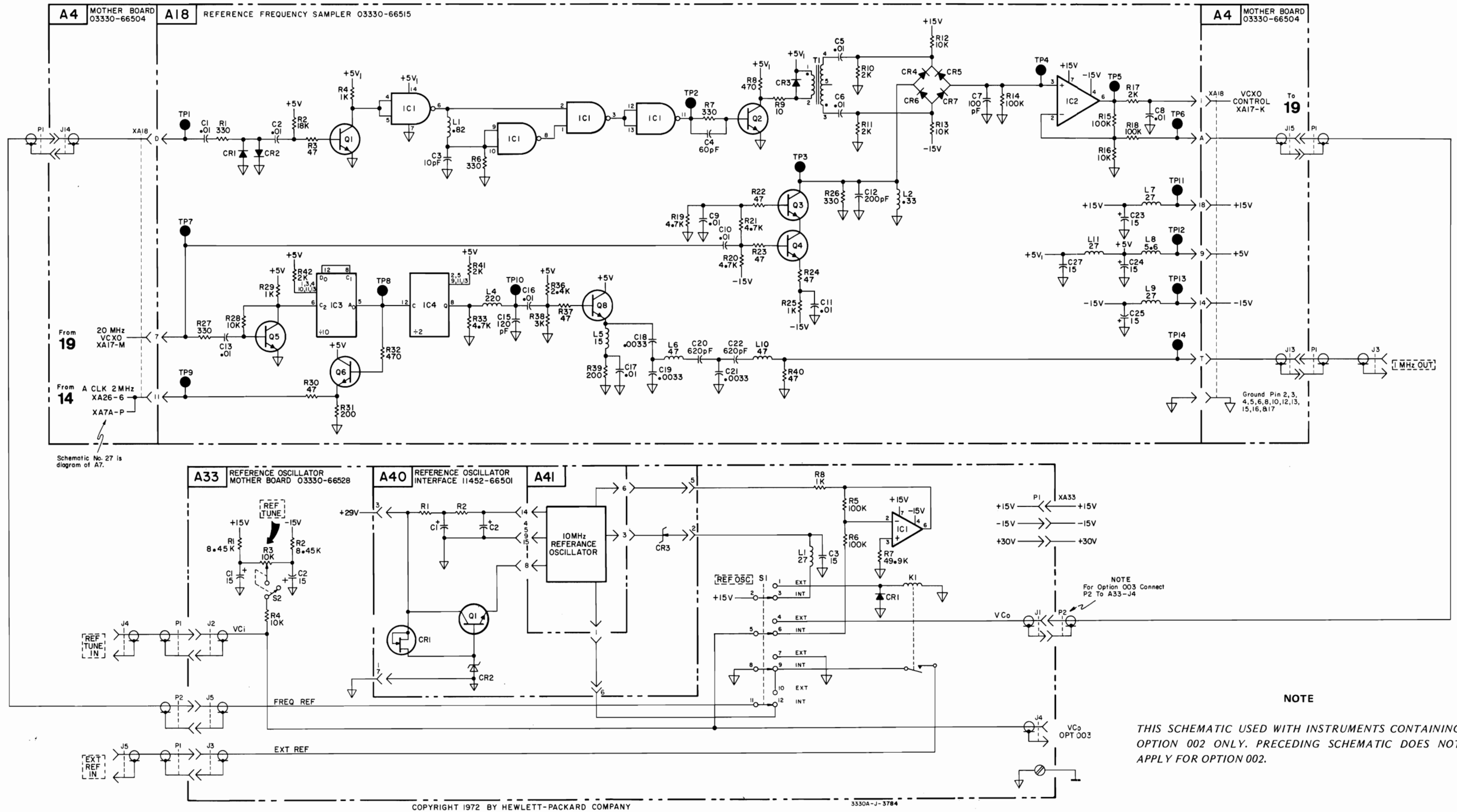
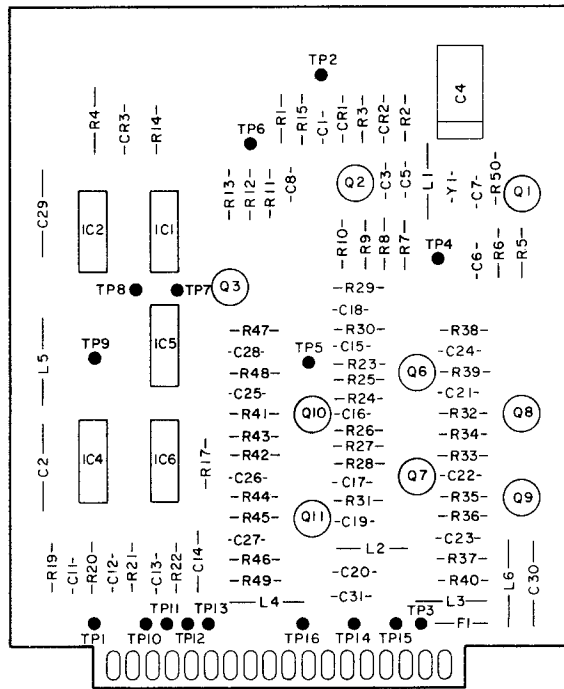

Figure 7-24. Ref Freq Sampler A18, Reference Oscillator A33. 7-59/7-60



3330A-B-2787

A17

hp Part No. 03330-66514

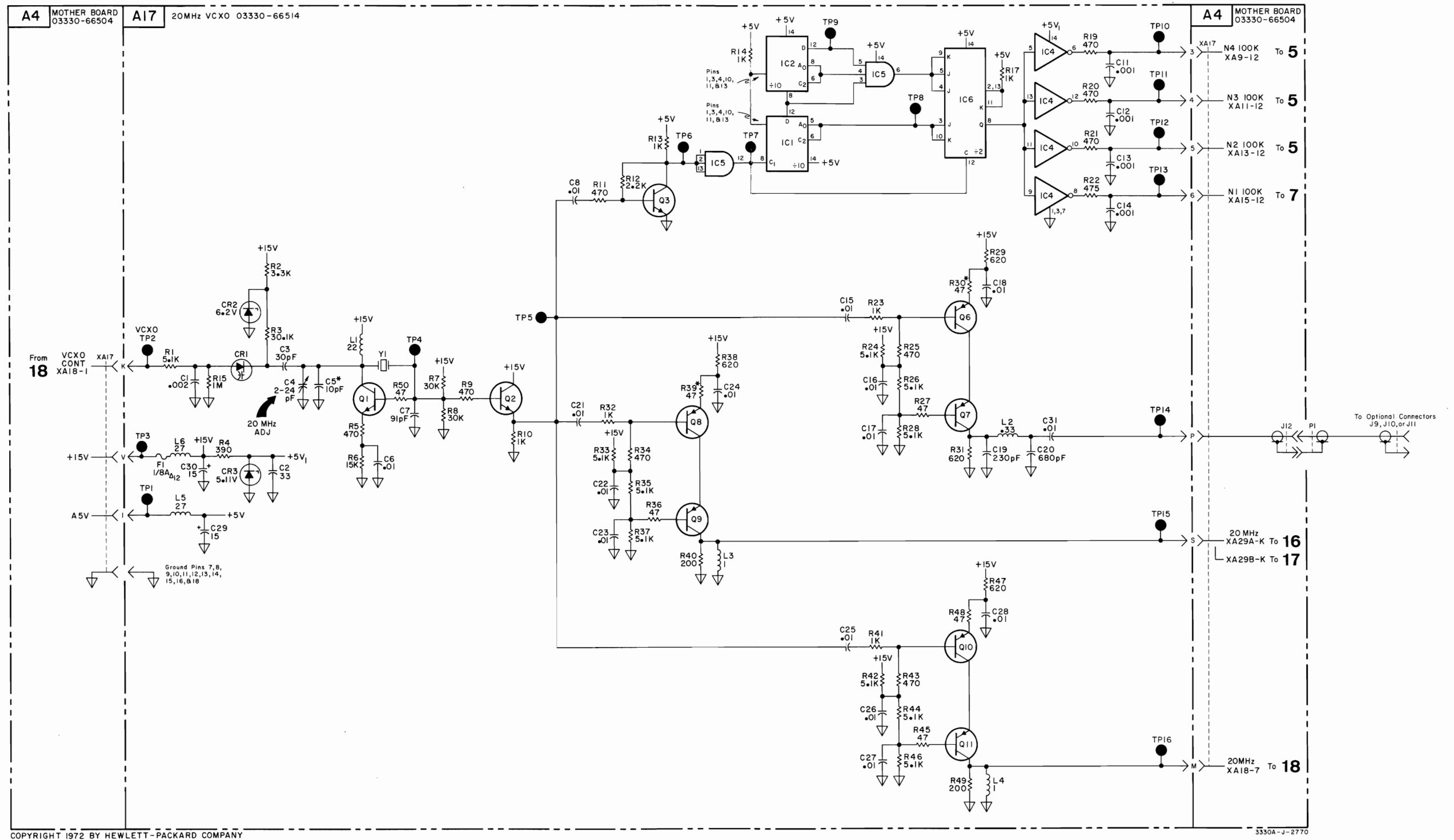

COPYRIGHT 1972 BY HEWLETT-PACKARD COMPANY

3330A-J-2770

Figure 7-25. 20 MHz VCXO A17.
7-61/7-62

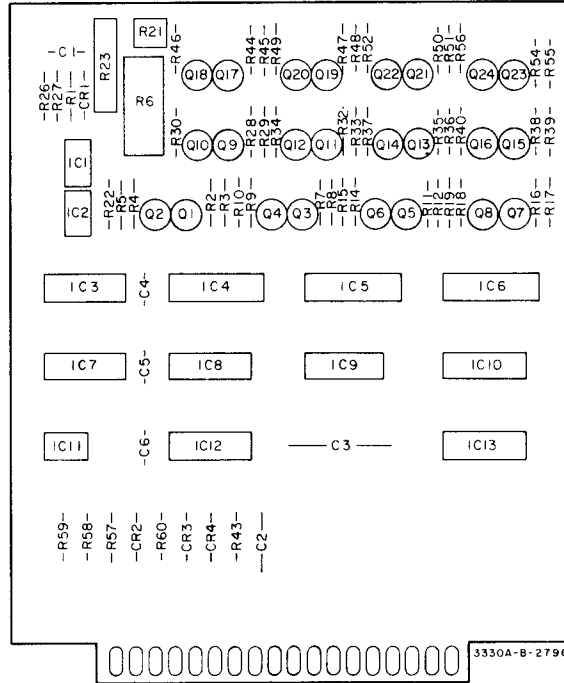

A19

hp Part No. 03330-66516

Q	XSTR COL CONNECTED TO R6 PIN
1, 2	1
3, 4	2
5, 6	3
7, 8	4
9, 10	5
11, 12	6
13, 14	7
15, 16	8
17, 18	9
19, 20	10
21, 22	11
23, 24	12

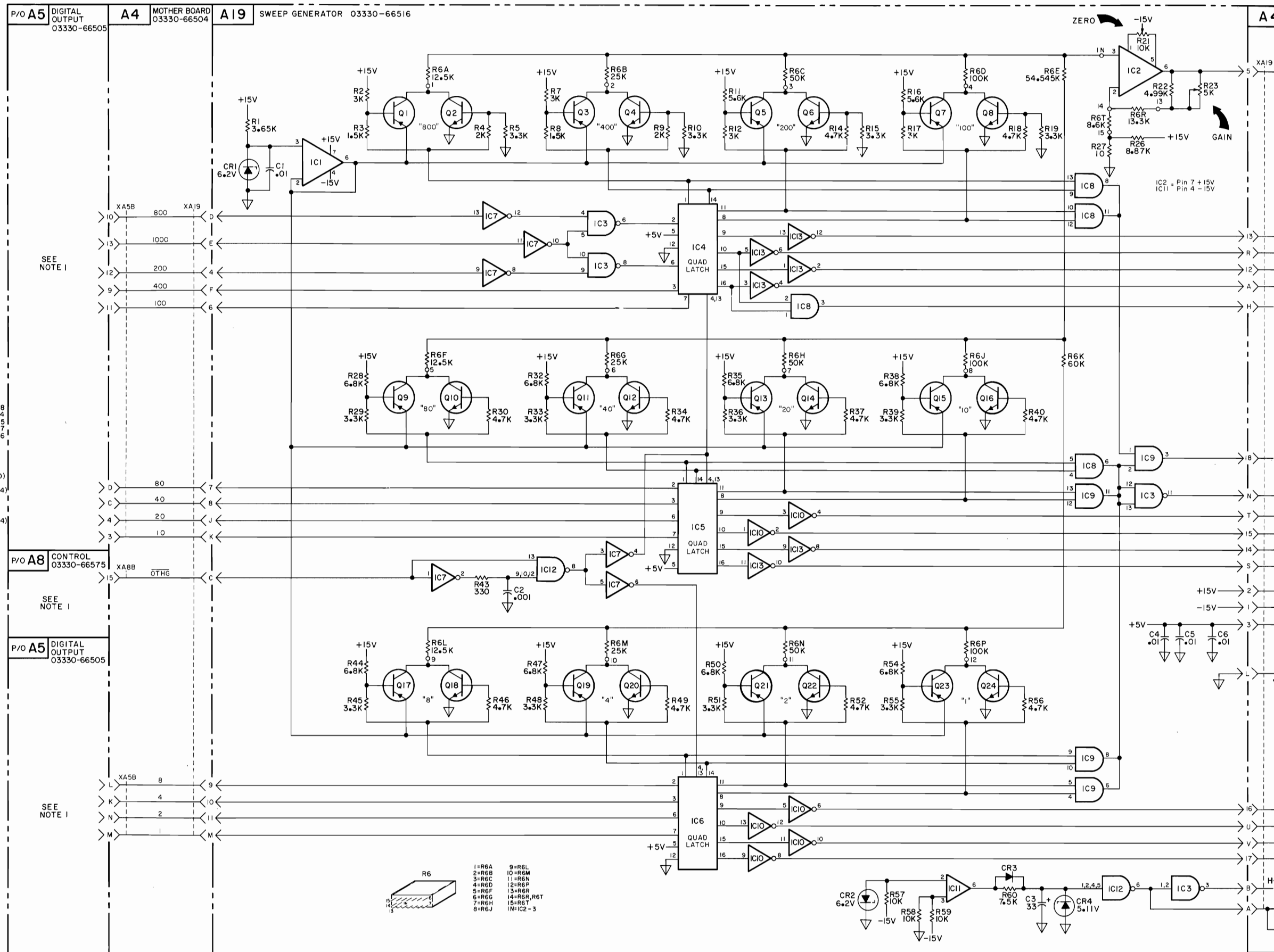

NOTE 1
Refer to the following diagrams:
A5 No. 28
A6(Standard) No. 24
A6(Opt. 004) No. 25
A7 No. 27
A8 No. 26

NOTE 2
03330-66576 (3330B STANDARD)
03330-66577 (3330B OPTION 004)
03330-66578 (3330A STANDARD)
03330-66579 (3330A OPTION 004)

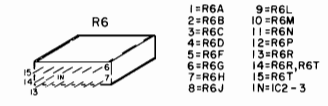

- 1=R6A
- 2=R6B
- 3=R6C
- 4=R6D
- 5=R6E
- 6=R6G
- 7=R6H
- 8=R6J
- 9=R6L
- 10=R6M
- 11=R6N
- 12=R6P
- 13=R6R
- 14=R6R, R6T
- 15=R6T
- 16=IC2-3

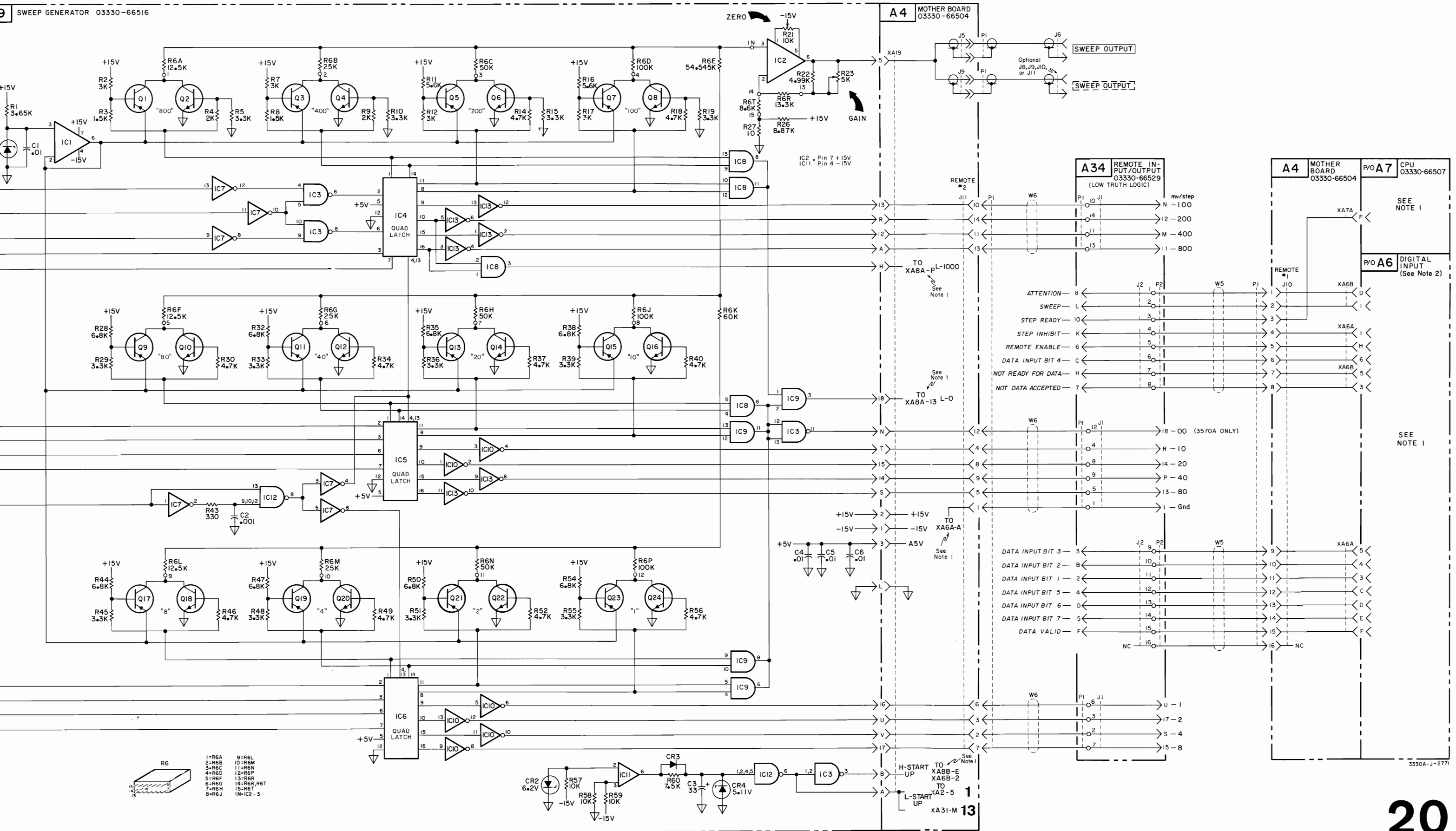
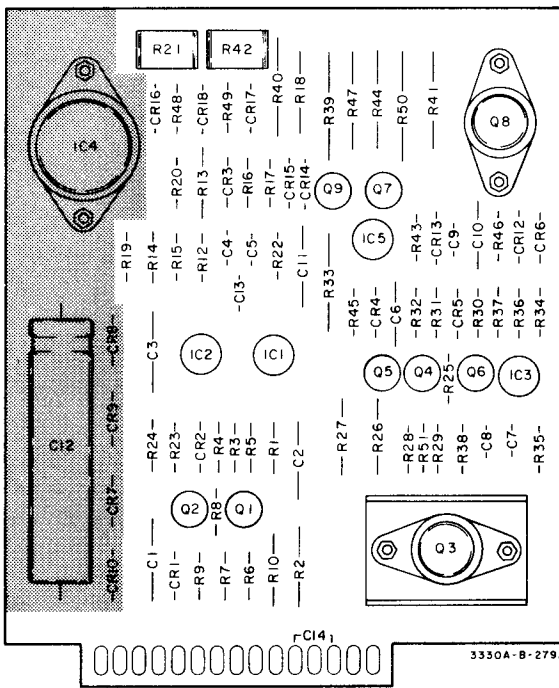

Figure 7-26. Sweep Generator A19, Remote Input/Output A34. 7-63/7-64

OPTION 004
ONLY

"OPTION 004"
hp Part No. 03330-66561



3330A-B-2793

A35

hp Part No. 03330-66530

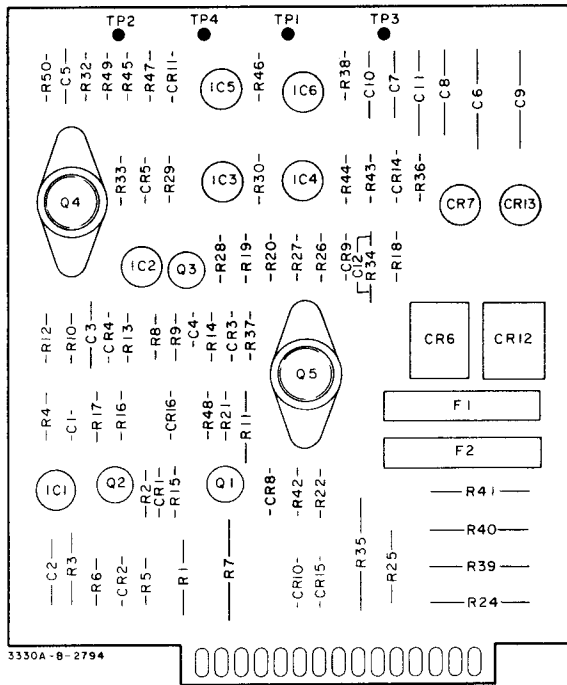

3330A-B-2794

A36

hp Part No. 03330-66531

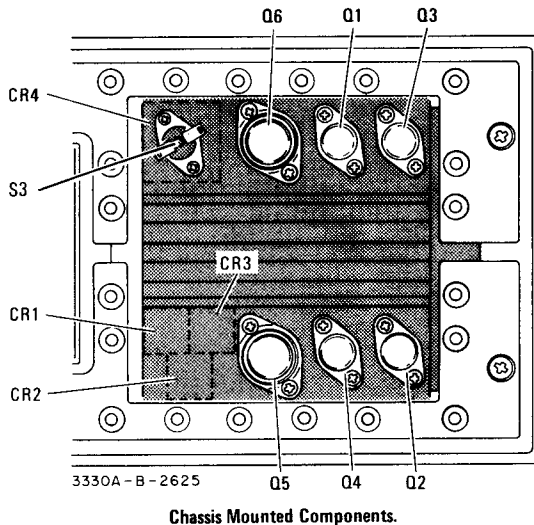

3330A-B-2625

Chassis Mounted Components.

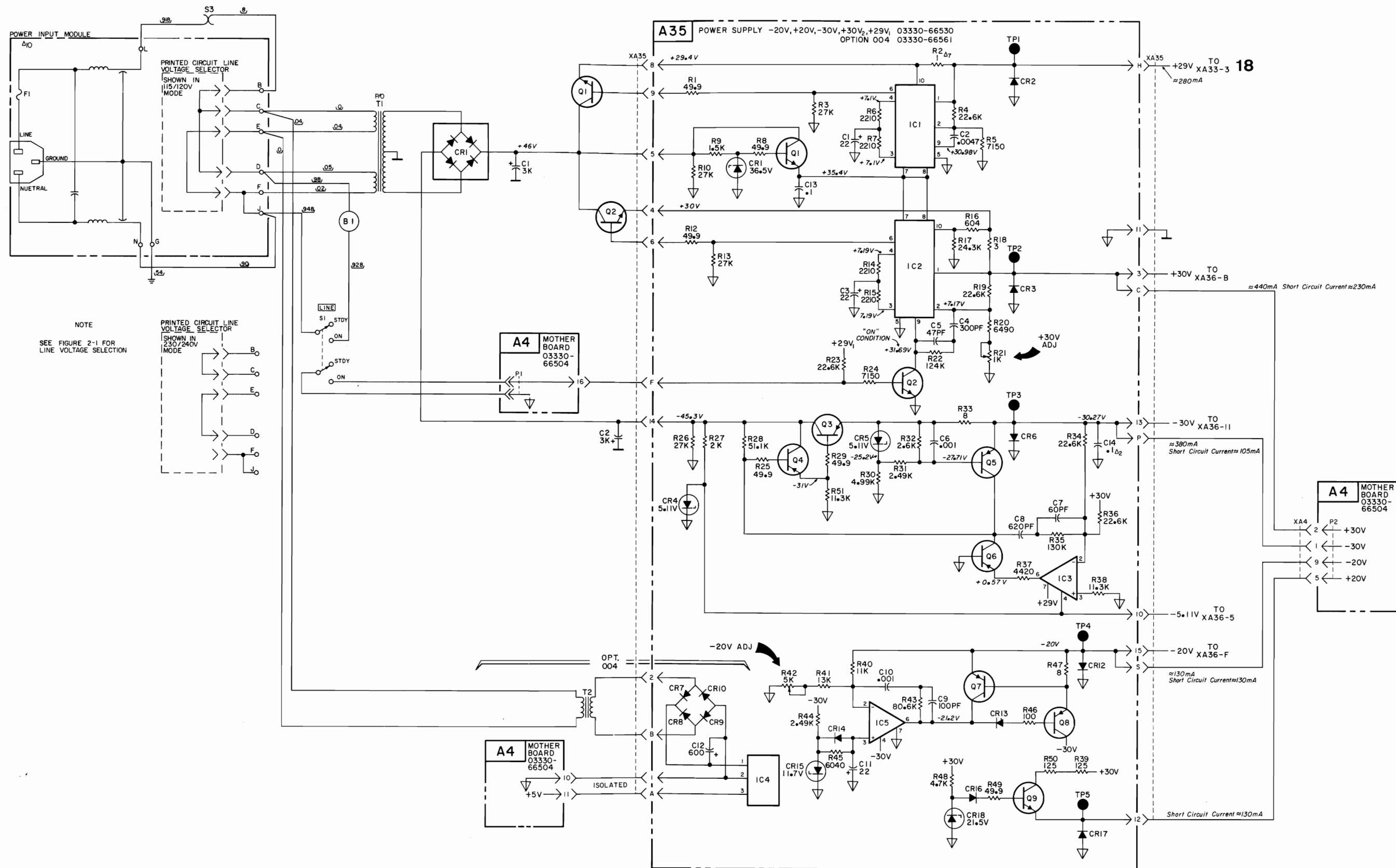

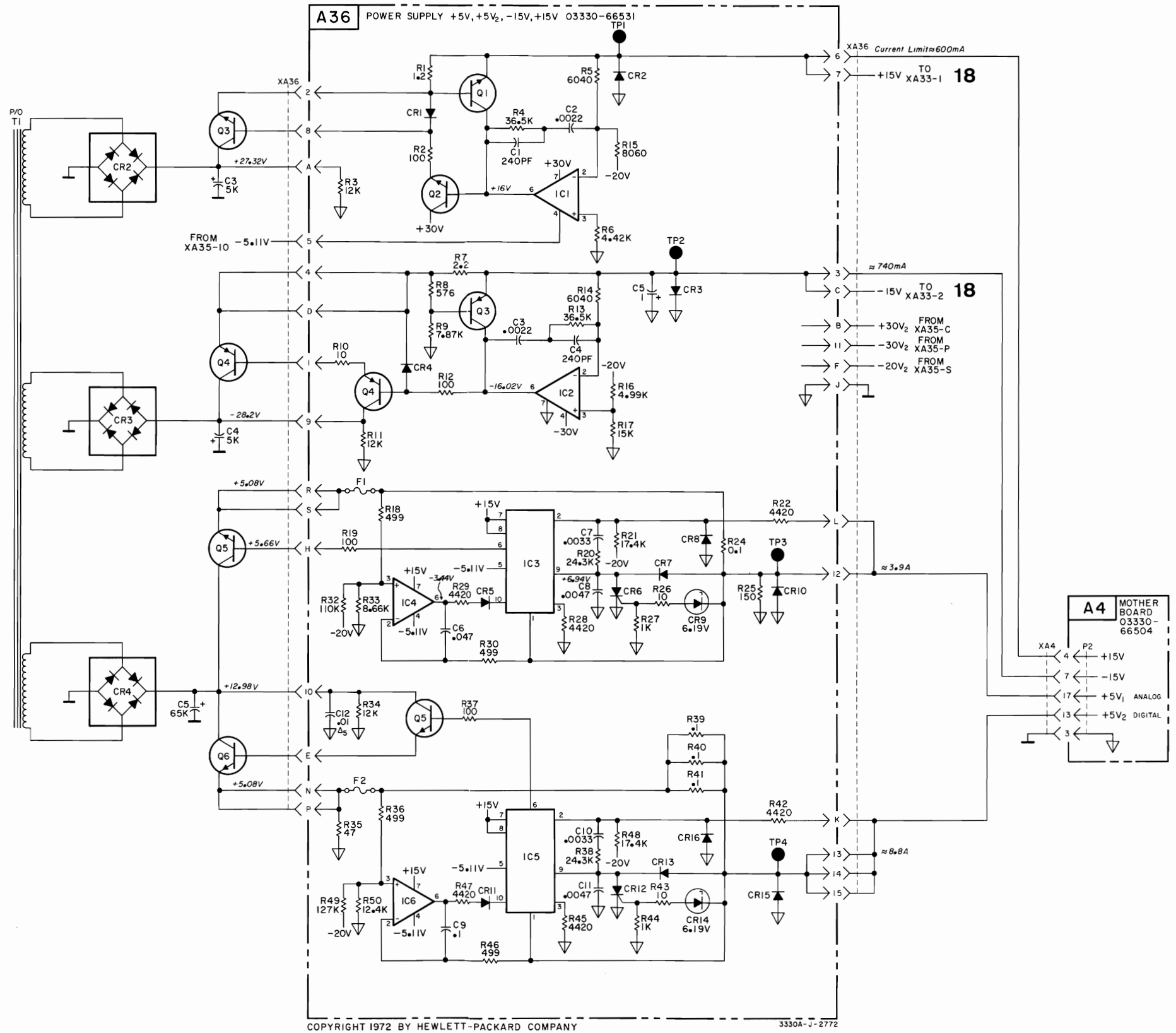
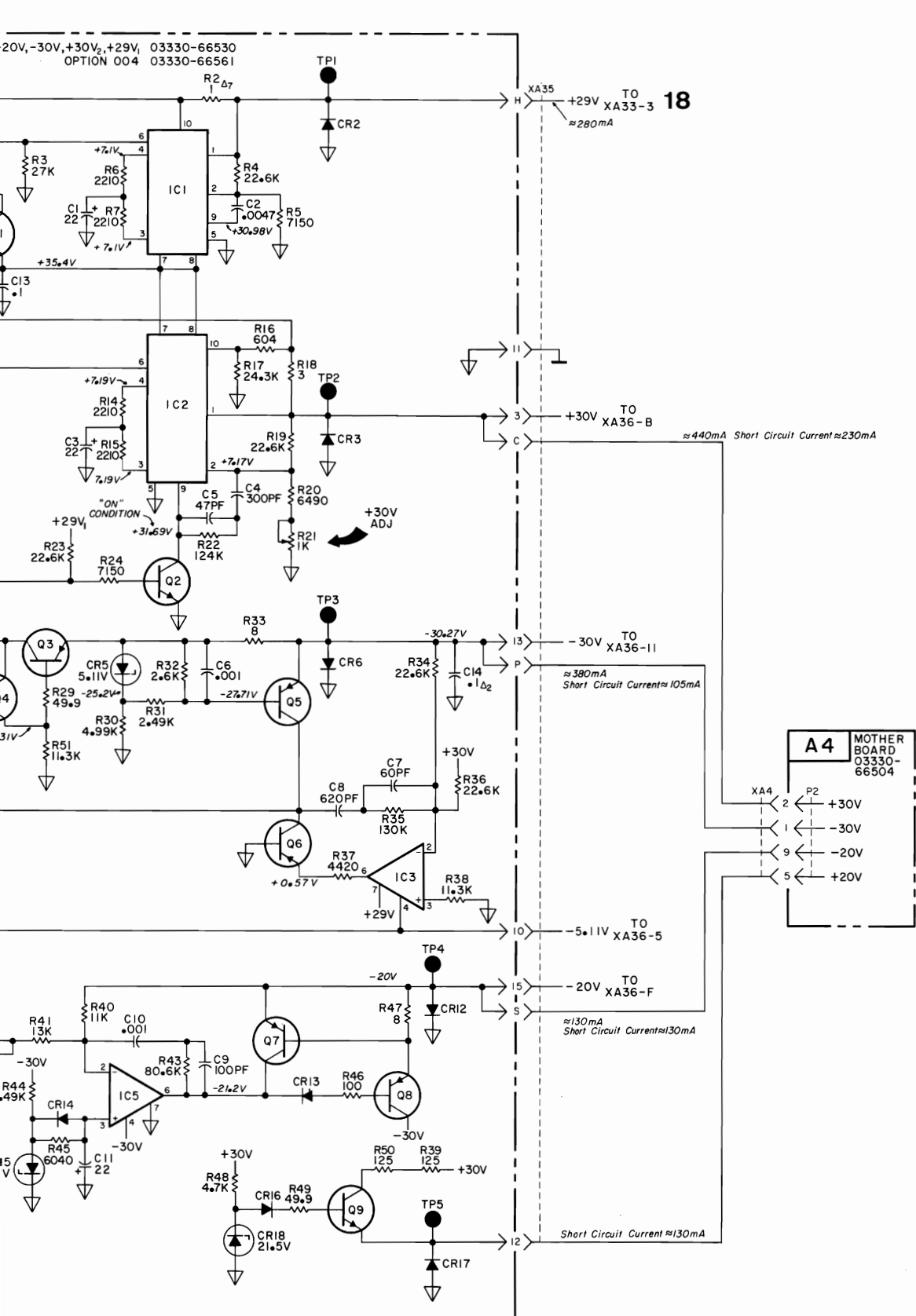
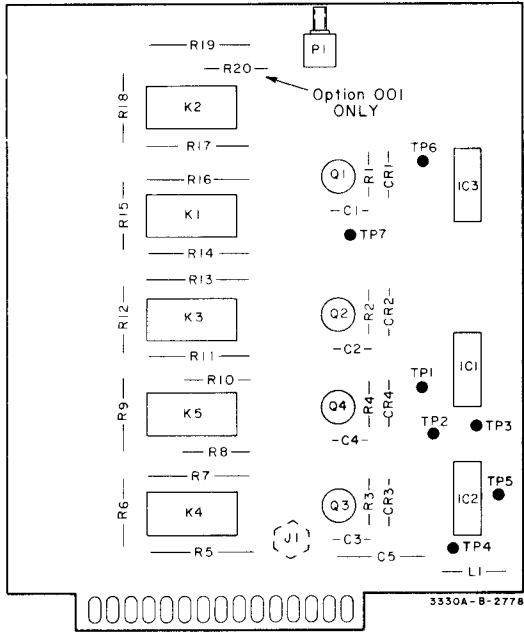
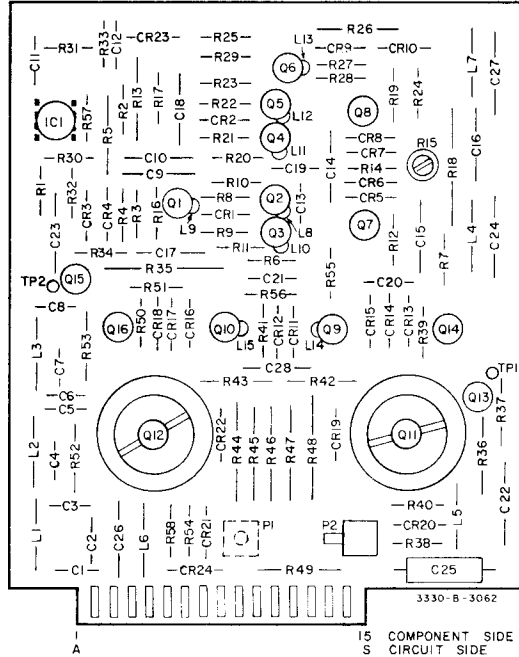

Figure 7-27. Power Supply A35, Power Supply A36A, Power Supply A36B.



A31

hp Part No. 03330-66526



A32A / B

hp Part No. 03330-66564
Rev. A

NOTE

SEE SCHEMATIC 24 OR 25 FOR AMPLITUDE CONSTANT SELECTION.

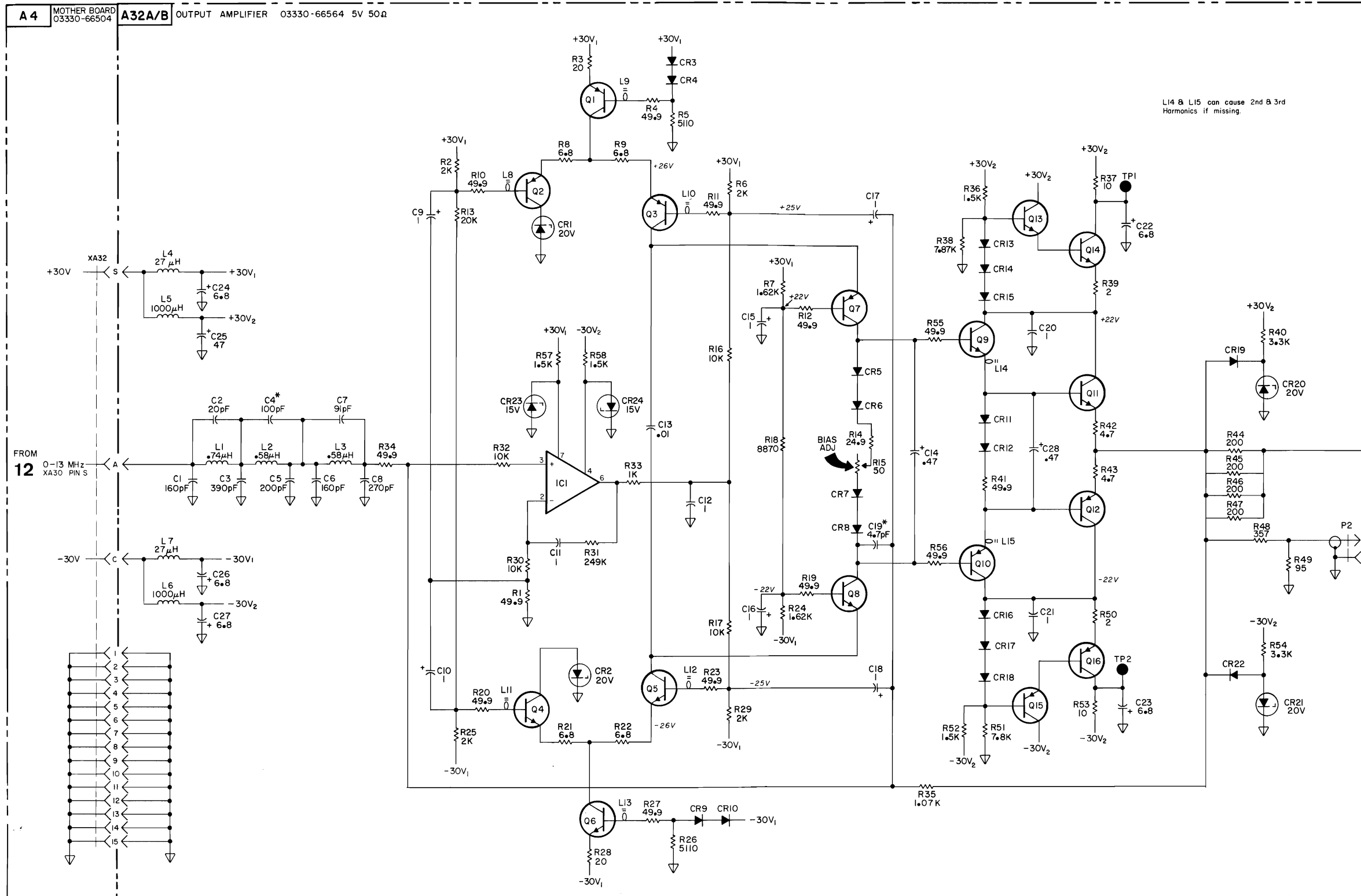

L14 & L15 can cause 2nd & 3rd Harmonics if missing.

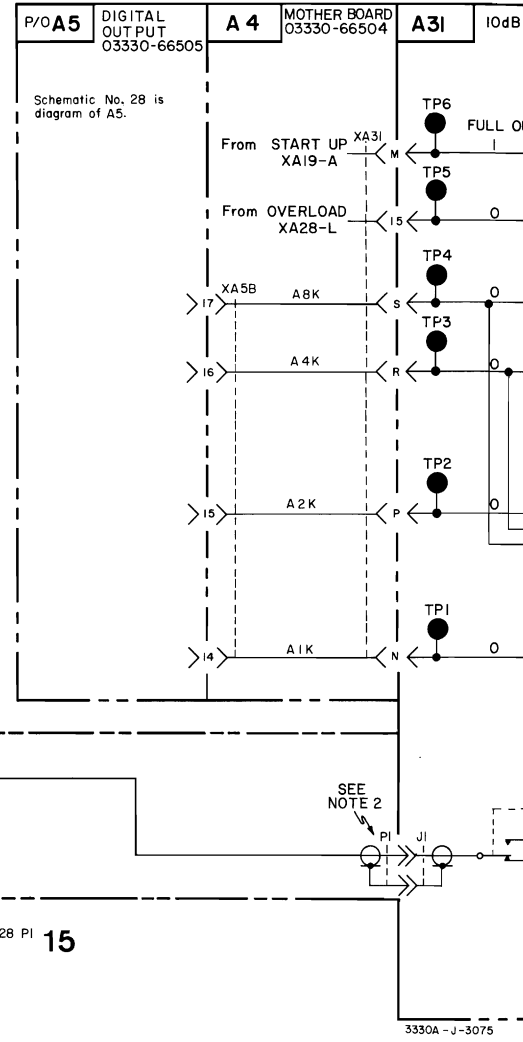

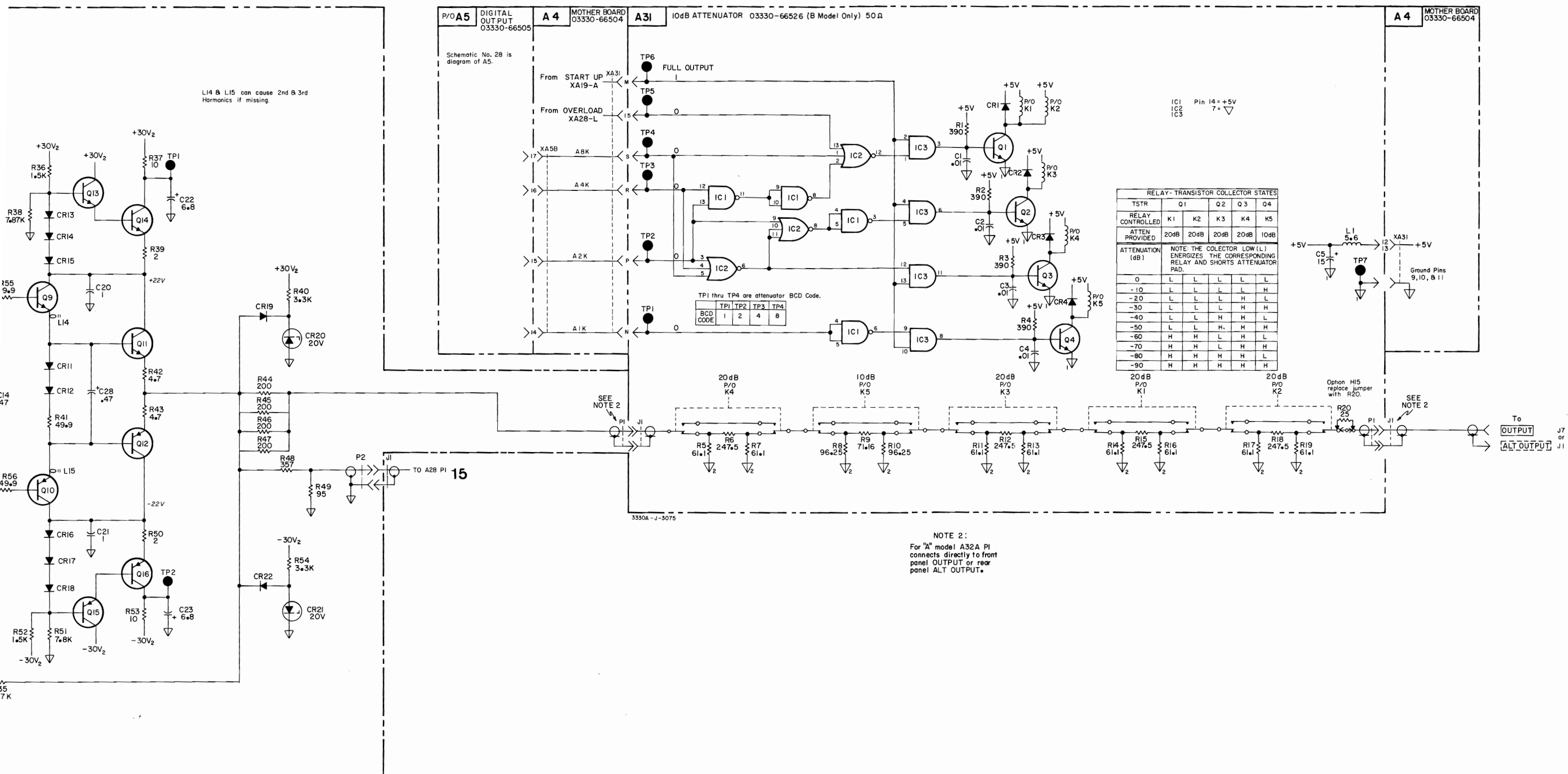

COPYRIGHT 1972 BY HEWLETT-PACKARD COMPANY

Figure 7-28. Attenuator A31 Output Amplifier A32A/B (Option 005, 5 V rms).

Table 7-3. Integrated Circuit Information.

Designator	Diagram No.	Designator	Diagram No.	Designator	Diagram No.
A5U5, U6	1	A7U1, U2, U3	10	A8U1 – U11	21
A5U8	2	A7U4	2	A8U12, U13	2
A5U16, U17	3	A7U5	11	A8U14	15
A5U18, U19	4	A7U7	21	A8U15	16
A5U20	2	A7U8	12	A8U16	15
A5U21, U22, U23, U24, U27, U28	5	A7U9	8	A8U17	17
A6U3	6	A7U10	10	A8U18	21
A6U14	7	A7U11	11	A8U19	18
A6U15	8	A7U15, U16	13	A8U21	19
A6U20	2	A7U18	8	A8U25	18
A6U21 (Std)	7	A7U19	10	A8U26	17
A6U22 (Opt 004)	7	A7U22	14	A8U27	1
A6U23	9	A7U25	9	A8U30, U31	20
A6U27	5	A7U27	10	A8U34	18
		A7U28	15	A8U36	12
		A7U30	4		
		A7U32, U33	9		

Dia. No.	Designator	-hp- Part No.	Mfr. Part No.	Diagram																																										
1	A5U5, U6 A8U27	1820-0301	SN7475	<p>4-bit Bistable Latch</p> <table border="1"> <thead> <tr> <th>D</th> <th>ENABLE</th> <th>Q</th> <th>\bar{Q}</th> </tr> </thead> <tbody> <tr> <td>L</td> <td>H</td> <td>L</td> <td>H</td> </tr> <tr> <td>H</td> <td>H</td> <td>H</td> <td>L</td> </tr> <tr> <td>X</td> <td>L</td> <td>Q_0</td> <td>\bar{Q}_0</td> </tr> </tbody> </table>	D	ENABLE	Q	\bar{Q}	L	H	L	H	H	H	H	L	X	L	Q_0	\bar{Q}_0																										
D	ENABLE	Q	\bar{Q}																																											
L	H	L	H																																											
H	H	H	L																																											
X	L	Q_0	\bar{Q}_0																																											
2	A5U8, U20 A6U20 A7U4 A8U12, U13	1820-0077	SN7474	<p>Dual D Flip-Flop</p> <table border="1"> <thead> <tr> <th>PRESET</th> <th>CLEAR</th> <th>CLOCK</th> <th>D</th> <th>Q</th> <th>\bar{Q}</th> </tr> </thead> <tbody> <tr> <td>L</td> <td>H</td> <td>X</td> <td>X</td> <td>H</td> <td>L</td> </tr> <tr> <td>H</td> <td>L</td> <td>X</td> <td>X</td> <td>L</td> <td>H</td> </tr> <tr> <td>L</td> <td>L</td> <td>X</td> <td>X</td> <td>UNSTABLE</td> <td></td> </tr> <tr> <td>H</td> <td>H</td> <td>↑</td> <td>H</td> <td>H</td> <td>L</td> </tr> <tr> <td>H</td> <td>H</td> <td>↑</td> <td>L</td> <td>L</td> <td>H</td> </tr> <tr> <td>H</td> <td>H</td> <td>L</td> <td>X</td> <td>Q_0</td> <td>\bar{Q}_0</td> </tr> </tbody> </table>	PRESET	CLEAR	CLOCK	D	Q	\bar{Q}	L	H	X	X	H	L	H	L	X	X	L	H	L	L	X	X	UNSTABLE		H	H	↑	H	H	L	H	H	↑	L	L	H	H	H	L	X	Q_0	\bar{Q}_0
PRESET	CLEAR	CLOCK	D	Q	\bar{Q}																																									
L	H	X	X	H	L																																									
H	L	X	X	L	H																																									
L	L	X	X	UNSTABLE																																										
H	H	↑	H	H	L																																									
H	H	↑	L	L	H																																									
H	H	L	X	Q_0	\bar{Q}_0																																									
3	A5U16, U17	1820-0294	SN74164	<p>8-Bit Shift Register (Serial In/Parallel Out)</p>																																										

Table 7-3. Integrated Circuit Information (Cont'd).

Dia. No.	Designator	-hp- Part No.	Mfr. Part No.	Diagram																														
4	A5U18, U19 A7U30	1820-0726	SN74199	<p>8-Bit Shift Register (Serial In/ Parallel Load/Parallel Out)</p> <table border="1" data-bbox="852 472 1453 630"> <thead> <tr> <th></th> <th>SHIFT/ CLEAR</th> <th>SHIFT/ LOAD</th> <th>CLOCK/ CLOCK INHIBIT</th> <th>OUTPUTS Q_A – Q_H</th> </tr> </thead> <tbody> <tr> <td>L</td> <td>X</td> <td>X</td> <td>X</td> <td>L</td> </tr> <tr> <td>H</td> <td>L</td> <td>L</td> <td>H</td> <td>PARALLEL ENTRY</td> </tr> <tr> <td>H</td> <td>H</td> <td>H</td> <td>↑</td> <td>SERIAL ENTRY (J, \bar{K}) AND SHIFT A → H</td> </tr> </tbody> </table>		SHIFT/ CLEAR	SHIFT/ LOAD	CLOCK/ CLOCK INHIBIT	OUTPUTS Q _A – Q _H	L	X	X	X	L	H	L	L	H	PARALLEL ENTRY	H	H	H	↑	SERIAL ENTRY (J, \bar{K}) AND SHIFT A → H										
	SHIFT/ CLEAR	SHIFT/ LOAD	CLOCK/ CLOCK INHIBIT	OUTPUTS Q _A – Q _H																														
L	X	X	X	L																														
H	L	L	H	PARALLEL ENTRY																														
H	H	H	↑	SERIAL ENTRY (J, \bar{K}) AND SHIFT A → H																														
5	A5U21, U22, U23, U24, U27, U28 A6U27	1820-0425	SN74100	<p>8-Bit Bistable Latch</p> <table border="1" data-bbox="1201 966 1380 1081"> <thead> <tr> <th>D</th> <th>ENABLE</th> <th>Q</th> </tr> </thead> <tbody> <tr> <td>L</td> <td>H</td> <td>L</td> </tr> <tr> <td>H</td> <td>H</td> <td>H</td> </tr> <tr> <td>X</td> <td>L</td> <td>Q₀</td> </tr> </tbody> </table>	D	ENABLE	Q	L	H	L	H	H	H	X	L	Q ₀																		
D	ENABLE	Q																																
L	H	L																																
H	H	H																																
X	L	Q ₀																																
6	A6U3	1820-0072	SN7450	<p>Dual AND–OR–Invert Gate</p>																														
7	A6U14, U21 (Standard) A6U14, U22 (Option 004)	1820-0616	9322	<p>Quad 2-Input Multiplexer</p> <p>Select input high selects Remote (1) inputs; low selects Local (0) inputs.</p> <table border="1" data-bbox="1039 1732 1339 1900"> <thead> <tr> <th>ENABLE</th> <th>SELECT</th> <th>0</th> <th>1</th> <th>Z</th> </tr> </thead> <tbody> <tr> <td>H</td> <td>X X</td> <td>X</td> <td>X</td> <td>L</td> </tr> <tr> <td>L</td> <td>H</td> <td>X</td> <td>L</td> <td>L</td> </tr> <tr> <td>L</td> <td>H</td> <td>X</td> <td>H</td> <td>H</td> </tr> <tr> <td>L</td> <td>L</td> <td>L</td> <td>X</td> <td>L</td> </tr> <tr> <td>L</td> <td>L</td> <td>H</td> <td>X</td> <td>H</td> </tr> </tbody> </table>	ENABLE	SELECT	0	1	Z	H	X X	X	X	L	L	H	X	L	L	L	H	X	H	H	L	L	L	X	L	L	L	H	X	H
ENABLE	SELECT	0	1	Z																														
H	X X	X	X	L																														
L	H	X	L	L																														
L	H	X	H	H																														
L	L	L	X	L																														
L	L	H	X	H																														

Table 7-3. Integrated Circuit Information (Cont'd).

Dia. No.	Designator	-hp- Part No.	Mfr. Part No.	Diagram																																																															
8	A6U15 A7U9, U18	1820-1042	SN74165	<p>8-Bit Shift Register (Serial In/ Parallel Load/Serial Out)</p>  <table border="1" data-bbox="941 346 1218 472"> <thead> <tr> <th>SHIFT/ LOAD</th> <th>CLOCK/ CLOCK INHIBIT</th> </tr> </thead> <tbody> <tr> <td>↓ L</td> <td>X ↑</td> </tr> </tbody> </table> <table border="1" data-bbox="1226 409 1453 483"> <tr> <td>PARALLEL ENTRY SERIAL ENTRY AND SHIFT A → H</td> </tr> </table>	SHIFT/ LOAD	CLOCK/ CLOCK INHIBIT	↓ L	X ↑	PARALLEL ENTRY SERIAL ENTRY AND SHIFT A → H																																																										
SHIFT/ LOAD	CLOCK/ CLOCK INHIBIT																																																																		
↓ L	X ↑																																																																		
PARALLEL ENTRY SERIAL ENTRY AND SHIFT A → H																																																																			
9	A6U23 A7U25, U32, U33	1820-0984	8270	<p>4-Bit Shift Register (Serial In/ Parallel Load/Parallel Out)</p>  <table border="1" data-bbox="1071 829 1453 945"> <thead> <tr> <th>LOAD</th> <th>SHIFT</th> <th>CONTROL STATE</th> </tr> </thead> <tbody> <tr> <td>L</td> <td>L</td> <td>NO CHANGE</td> </tr> <tr> <td>H</td> <td>L</td> <td>PARALLEL ENTRY</td> </tr> <tr> <td>X</td> <td>H</td> <td>SHIFT RIGHT</td> </tr> </tbody> </table>	LOAD	SHIFT	CONTROL STATE	L	L	NO CHANGE	H	L	PARALLEL ENTRY	X	H	SHIFT RIGHT																																																			
LOAD	SHIFT	CONTROL STATE																																																																	
L	L	NO CHANGE																																																																	
H	L	PARALLEL ENTRY																																																																	
X	H	SHIFT RIGHT																																																																	
10	A7U1, U2, U3 U10, U19, U27	1820-0055	SN7490	<p>Decade Counter</p>  <p>Q_A output is a symmetrical divide-by-ten square wave when Q_D is connected to A_{IN} and the input count is applied to B_{IN}.</p> <p>COUNT SEQUENCE</p> <table border="1" data-bbox="1039 1207 1242 1491"> <thead> <tr> <th></th> <th>Q_D</th> <th>Q_A</th> </tr> </thead> <tbody> <tr><td>0</td><td>L</td><td>L</td></tr> <tr><td>1</td><td>L</td><td>L</td></tr> <tr><td>2</td><td>L</td><td>L</td></tr> <tr><td>3</td><td>L</td><td>L</td></tr> <tr><td>4</td><td>H</td><td>L</td></tr> <tr><td>5</td><td>L</td><td>H</td></tr> <tr><td>6</td><td>L</td><td>H</td></tr> <tr><td>7</td><td>L</td><td>H</td></tr> <tr><td>8</td><td>L</td><td>H</td></tr> <tr><td>9</td><td>H</td><td>H</td></tr> </tbody> </table> <table border="1" data-bbox="641 1407 1015 1543"> <thead> <tr> <th>RO1</th> <th>RO2</th> <th>RG1</th> <th>RG2</th> <th>Q_A</th> <th>Q_D</th> </tr> </thead> <tbody> <tr> <td>X</td> <td>L</td> <td>X</td> <td>L</td> <td>COUNT</td> <td>COUNT</td> </tr> <tr> <td>L</td> <td>X</td> <td>L</td> <td>X</td> <td>COUNT</td> <td>COUNT</td> </tr> <tr> <td>L</td> <td>X</td> <td>X</td> <td>L</td> <td>COUNT</td> <td>COUNT</td> </tr> <tr> <td>X</td> <td>L</td> <td>L</td> <td>X</td> <td>COUNT</td> <td>COUNT</td> </tr> </tbody> </table>		Q_D	Q_A	0	L	L	1	L	L	2	L	L	3	L	L	4	H	L	5	L	H	6	L	H	7	L	H	8	L	H	9	H	H	RO1	RO2	RG1	RG2	Q_A	Q_D	X	L	X	L	COUNT	COUNT	L	X	L	X	COUNT	COUNT	L	X	X	L	COUNT	COUNT	X	L	L	X	COUNT	COUNT
	Q_D	Q_A																																																																	
0	L	L																																																																	
1	L	L																																																																	
2	L	L																																																																	
3	L	L																																																																	
4	H	L																																																																	
5	L	H																																																																	
6	L	H																																																																	
7	L	H																																																																	
8	L	H																																																																	
9	H	H																																																																	
RO1	RO2	RG1	RG2	Q_A	Q_D																																																														
X	L	X	L	COUNT	COUNT																																																														
L	X	L	X	COUNT	COUNT																																																														
L	X	X	L	COUNT	COUNT																																																														
X	L	L	X	COUNT	COUNT																																																														
11	A7U5, U11	1820-0281	SN74107	<p>Dual J-K Flip-Flop</p>  <table border="1" data-bbox="1055 1669 1437 1837"> <thead> <tr> <th>CLEAR</th> <th>CLOCK</th> <th>J</th> <th>K</th> <th>Q</th> <th>\bar{Q}</th> </tr> </thead> <tbody> <tr> <td>L</td> <td>X</td> <td>X</td> <td>X</td> <td>L</td> <td>H</td> </tr> <tr> <td>H</td> <td>↓</td> <td>L</td> <td>L</td> <td>Q_0</td> <td>\bar{Q}_0</td> </tr> <tr> <td>H</td> <td>↓</td> <td>H</td> <td>L</td> <td>H</td> <td>L</td> </tr> <tr> <td>H</td> <td>↓</td> <td>L</td> <td>H</td> <td>L</td> <td>H</td> </tr> <tr> <td>H</td> <td>↓</td> <td>H</td> <td>H</td> <td>TOGGLE</td> <td>TOGGLE</td> </tr> </tbody> </table>	CLEAR	CLOCK	J	K	Q	\bar{Q}	L	X	X	X	L	H	H	↓	L	L	Q_0	\bar{Q}_0	H	↓	H	L	H	L	H	↓	L	H	L	H	H	↓	H	H	TOGGLE	TOGGLE																											
CLEAR	CLOCK	J	K	Q	\bar{Q}																																																														
L	X	X	X	L	H																																																														
H	↓	L	L	Q_0	\bar{Q}_0																																																														
H	↓	H	L	H	L																																																														
H	↓	L	H	L	H																																																														
H	↓	H	H	TOGGLE	TOGGLE																																																														

Table 7-3. Integrated Circuit Information (Cont'd).

Dia. No.	Designator	-hp- Part No.	Mfr. Part No.	Diagram																																										
12	A7U8 A8U36	1820-0544	SN74H103	<p>Dual J-K Flip-Flop</p>  <table border="1" data-bbox="1039 357 1412 546"> <thead> <tr> <th>CLEAR</th> <th>CLOCK</th> <th>J</th> <th>K</th> <th>Q</th> <th>\bar{Q}</th> </tr> </thead> <tbody> <tr> <td>L</td> <td>X</td> <td>X</td> <td>X</td> <td>L</td> <td>H</td> </tr> <tr> <td>H</td> <td>↓</td> <td>L</td> <td>L</td> <td>Q₀</td> <td>\bar{Q}_0</td> </tr> <tr> <td>H</td> <td>↓</td> <td>H</td> <td>L</td> <td>H</td> <td>L</td> </tr> <tr> <td>H</td> <td>↓</td> <td>L</td> <td>H</td> <td>L</td> <td>H</td> </tr> <tr> <td>H</td> <td>↓</td> <td>H</td> <td>H</td> <td>TOGGLE</td> <td>TOGGLE</td> </tr> <tr> <td>H</td> <td>↓</td> <td>X</td> <td>X</td> <td>Q₀</td> <td>\bar{Q}_0</td> </tr> </tbody> </table>	CLEAR	CLOCK	J	K	Q	\bar{Q}	L	X	X	X	L	H	H	↓	L	L	Q ₀	\bar{Q}_0	H	↓	H	L	H	L	H	↓	L	H	L	H	H	↓	H	H	TOGGLE	TOGGLE	H	↓	X	X	Q ₀	\bar{Q}_0
CLEAR	CLOCK	J	K	Q	\bar{Q}																																									
L	X	X	X	L	H																																									
H	↓	L	L	Q ₀	\bar{Q}_0																																									
H	↓	H	L	H	L																																									
H	↓	L	H	L	H																																									
H	↓	H	H	TOGGLE	TOGGLE																																									
H	↓	X	X	Q ₀	\bar{Q}_0																																									
13	A7U15, U16	1820-0084	SN7453	<p>4-Wide AND-OR-Invert Gate</p> 																																										
14	A7U22	1820-0400	8281	<p>Presetable Binary Counter</p>  <p>Load input low presets counter to levels at inputs D_A, D_B, D_C, D_D.</p>																																										
15	A7U28 A8U14, U16	1820-0839	SN74175	<p>Quad D Flip-Flop</p>  <table border="1" data-bbox="1079 1344 1404 1480"> <thead> <tr> <th>CLEAR</th> <th>CLOCK</th> <th>D</th> <th>Q</th> <th>\bar{Q}</th> </tr> </thead> <tbody> <tr> <td>L</td> <td>X</td> <td>X</td> <td>L</td> <td>H</td> </tr> <tr> <td>H</td> <td>↑</td> <td>H</td> <td>H</td> <td>L</td> </tr> <tr> <td>H</td> <td>↑</td> <td>L</td> <td>L</td> <td>H</td> </tr> <tr> <td>H</td> <td>↑</td> <td>X</td> <td>Q₀</td> <td>\bar{Q}_0</td> </tr> </tbody> </table>	CLEAR	CLOCK	D	Q	\bar{Q}	L	X	X	L	H	H	↑	H	H	L	H	↑	L	L	H	H	↑	X	Q ₀	\bar{Q}_0																	
CLEAR	CLOCK	D	Q	\bar{Q}																																										
L	X	X	L	H																																										
H	↑	H	H	L																																										
H	↑	L	L	H																																										
H	↑	X	Q ₀	\bar{Q}_0																																										
16	A8U15	1820-0727	9321	<p>Dual Decoder</p>  <table border="1" data-bbox="1096 1690 1453 1858"> <thead> <tr> <th>ENABLE</th> <th>A</th> <th>B</th> <th>0</th> <th>1</th> <th>2</th> <th>3</th> </tr> </thead> <tbody> <tr> <td>L</td> <td>L</td> <td>L</td> <td>L</td> <td>H</td> <td>H</td> <td>H</td> </tr> <tr> <td>L</td> <td>H</td> <td>L</td> <td>L</td> <td>H</td> <td>L</td> <td>H</td> </tr> <tr> <td>L</td> <td>L</td> <td>H</td> <td>H</td> <td>H</td> <td>L</td> <td>H</td> </tr> <tr> <td>L</td> <td>H</td> <td>H</td> <td>H</td> <td>H</td> <td>H</td> <td>L</td> </tr> <tr> <td>H</td> <td>X</td> <td>X</td> <td>H</td> <td>H</td> <td>H</td> <td>H</td> </tr> </tbody> </table>	ENABLE	A	B	0	1	2	3	L	L	L	L	H	H	H	L	H	L	L	H	L	H	L	L	H	H	H	L	H	L	H	H	H	H	H	L	H	X	X	H	H	H	H
ENABLE	A	B	0	1	2	3																																								
L	L	L	L	H	H	H																																								
L	H	L	L	H	L	H																																								
L	L	H	H	H	L	H																																								
L	H	H	H	H	H	L																																								
H	X	X	H	H	H	H																																								

Table 7-3. Integrated Circuit Information (Cont'd).

Dia. No.	Designator	-hp- Part No.	Mfr. Part No.	Diagram																																																																																																																																																										
17	A8U17, U26	1820-0998	SN74S153	<p>Dual Multiplexer</p>  <table border="1" data-bbox="1112 441 1347 598"> <thead> <tr> <th>B</th> <th>A</th> <th>ENABLE</th> <th>Y</th> </tr> </thead> <tbody> <tr> <td>X</td> <td>X</td> <td>H</td> <td>L</td> </tr> <tr> <td>L</td> <td>L</td> <td>L</td> <td>C0</td> </tr> <tr> <td>L</td> <td>H</td> <td>L</td> <td>C1</td> </tr> <tr> <td>H</td> <td>L</td> <td>L</td> <td>C2</td> </tr> <tr> <td>H</td> <td>H</td> <td>L</td> <td>C3</td> </tr> </tbody> </table>	B	A	ENABLE	Y	X	X	H	L	L	L	L	C0	L	H	L	C1	H	L	L	C2	H	H	L	C3																																																																																																																																		
B	A	ENABLE	Y																																																																																																																																																											
X	X	H	L																																																																																																																																																											
L	L	L	C0																																																																																																																																																											
L	H	L	C1																																																																																																																																																											
H	L	L	C2																																																																																																																																																											
H	H	L	C3																																																																																																																																																											
18	A8U19, U25, U34	1820-0214	SN7442	<p>BCD-to-Decimal Decoder</p>  <p>Binary Coded Decimal Input Grounds one output line.</p> <table border="1" data-bbox="982 882 1437 1155"> <thead> <tr> <th>D</th> <th>C</th> <th>B</th> <th>A</th> <th>0</th> <th>1</th> <th>2</th> <th>3</th> <th>4</th> <th>5</th> <th>6</th> <th>7</th> <th>8</th> <th>9</th> </tr> </thead> <tbody> <tr><td>L</td><td>L</td><td>L</td><td>L</td><td>L</td><td>H</td><td>H</td><td>H</td><td>H</td><td>H</td><td>H</td><td>H</td><td>H</td><td>H</td></tr> <tr><td>L</td><td>L</td><td>L</td><td>H</td><td>H</td><td>L</td><td>H</td><td>H</td><td>H</td><td>H</td><td>H</td><td>H</td><td>H</td><td>H</td></tr> <tr><td>L</td><td>L</td><td>H</td><td>L</td><td>H</td><td>H</td><td>L</td><td>H</td><td>H</td><td>H</td><td>H</td><td>H</td><td>H</td><td>H</td></tr> <tr><td>L</td><td>L</td><td>H</td><td>H</td><td>H</td><td>H</td><td>L</td><td>L</td><td>H</td><td>H</td><td>H</td><td>H</td><td>H</td><td>H</td></tr> <tr><td>L</td><td>H</td><td>L</td><td>L</td><td>H</td><td>H</td><td>H</td><td>H</td><td>L</td><td>H</td><td>H</td><td>H</td><td>H</td><td>H</td></tr> <tr><td>L</td><td>H</td><td>L</td><td>H</td><td>H</td><td>H</td><td>H</td><td>H</td><td>L</td><td>L</td><td>H</td><td>H</td><td>H</td><td>H</td></tr> <tr><td>L</td><td>H</td><td>H</td><td>L</td><td>H</td><td>H</td><td>H</td><td>H</td><td>H</td><td>L</td><td>L</td><td>H</td><td>H</td><td>H</td></tr> <tr><td>L</td><td>H</td><td>H</td><td>H</td><td>H</td><td>H</td><td>H</td><td>H</td><td>H</td><td>L</td><td>L</td><td>L</td><td>H</td><td>H</td></tr> <tr><td>H</td><td>L</td><td>L</td><td>L</td><td>H</td><td>H</td><td>H</td><td>H</td><td>H</td><td>H</td><td>H</td><td>L</td><td>L</td><td>H</td></tr> <tr><td>H</td><td>L</td><td>L</td><td>H</td><td>H</td><td>H</td><td>H</td><td>H</td><td>H</td><td>H</td><td>H</td><td>H</td><td>L</td><td>L</td></tr> </tbody> </table>	D	C	B	A	0	1	2	3	4	5	6	7	8	9	L	L	L	L	L	H	H	H	H	H	H	H	H	H	L	L	L	H	H	L	H	H	H	H	H	H	H	H	L	L	H	L	H	H	L	H	H	H	H	H	H	H	L	L	H	H	H	H	L	L	H	H	H	H	H	H	L	H	L	L	H	H	H	H	L	H	H	H	H	H	L	H	L	H	H	H	H	H	L	L	H	H	H	H	L	H	H	L	H	H	H	H	H	L	L	H	H	H	L	H	H	H	H	H	H	H	H	L	L	L	H	H	H	L	L	L	H	H	H	H	H	H	H	L	L	H	H	L	L	H	H	H	H	H	H	H	H	H	L	L
D	C	B	A	0	1	2	3	4	5	6	7	8	9																																																																																																																																																	
L	L	L	L	L	H	H	H	H	H	H	H	H	H																																																																																																																																																	
L	L	L	H	H	L	H	H	H	H	H	H	H	H																																																																																																																																																	
L	L	H	L	H	H	L	H	H	H	H	H	H	H																																																																																																																																																	
L	L	H	H	H	H	L	L	H	H	H	H	H	H																																																																																																																																																	
L	H	L	L	H	H	H	H	L	H	H	H	H	H																																																																																																																																																	
L	H	L	H	H	H	H	H	L	L	H	H	H	H																																																																																																																																																	
L	H	H	L	H	H	H	H	H	L	L	H	H	H																																																																																																																																																	
L	H	H	H	H	H	H	H	H	L	L	L	H	H																																																																																																																																																	
H	L	L	L	H	H	H	H	H	H	H	L	L	H																																																																																																																																																	
H	L	L	H	H	H	H	H	H	H	H	H	L	L																																																																																																																																																	
19	A8U21	1820-0381	SN74H54	<p>4-Wide AND-OR-Invert Gate</p> 																																																																																																																																																										

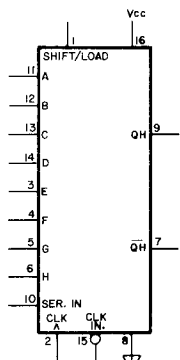
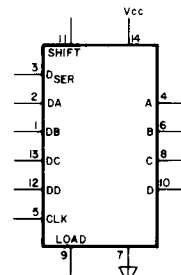
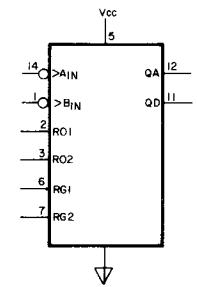
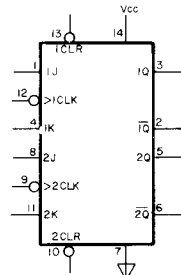
Table 7-3. Integrated Circuit Information (Cont'd).

Dia. No.	Designator	-hp- Part No.	Mfr. Part No.	Diagram																																																																																																												
20	A8U30, U31	1820-0640	SN74150	<p>Data Selector</p>  <table border="1" data-bbox="1149 273 1453 709"> <thead> <tr> <th>D</th> <th>C</th> <th>B</th> <th>A</th> <th>ENABLE</th> <th>W</th> </tr> </thead> <tbody> <tr> <td>X</td> <td>X</td> <td>X</td> <td>X</td> <td>H</td> <td>H</td> </tr> <tr> <td>L</td> <td>L</td> <td>L</td> <td>L</td> <td>L</td> <td>E0</td> </tr> <tr> <td>L</td> <td>L</td> <td>L</td> <td>H</td> <td>L</td> <td>E1</td> </tr> <tr> <td>L</td> <td>L</td> <td>H</td> <td>L</td> <td>L</td> <td>E2</td> </tr> <tr> <td>L</td> <td>L</td> <td>H</td> <td>H</td> <td>L</td> <td>E3</td> </tr> <tr> <td>L</td> <td>H</td> <td>L</td> <td>L</td> <td>L</td> <td>E4</td> </tr> <tr> <td>L</td> <td>H</td> <td>L</td> <td>H</td> <td>L</td> <td>E5</td> </tr> <tr> <td>L</td> <td>H</td> <td>H</td> <td>L</td> <td>L</td> <td>E6</td> </tr> <tr> <td>L</td> <td>H</td> <td>H</td> <td>H</td> <td>L</td> <td>E7</td> </tr> <tr> <td>H</td> <td>L</td> <td>L</td> <td>L</td> <td>L</td> <td>E8</td> </tr> <tr> <td>H</td> <td>L</td> <td>L</td> <td>H</td> <td>L</td> <td>E9</td> </tr> <tr> <td>H</td> <td>L</td> <td>H</td> <td>L</td> <td>L</td> <td>E10</td> </tr> <tr> <td>H</td> <td>L</td> <td>H</td> <td>H</td> <td>L</td> <td>E11</td> </tr> <tr> <td>H</td> <td>H</td> <td>L</td> <td>L</td> <td>L</td> <td>E12</td> </tr> <tr> <td>H</td> <td>H</td> <td>L</td> <td>H</td> <td>L</td> <td>E13</td> </tr> <tr> <td>H</td> <td>H</td> <td>H</td> <td>L</td> <td>L</td> <td>E14</td> </tr> <tr> <td>H</td> <td>H</td> <td>H</td> <td>H</td> <td>L</td> <td>E15</td> </tr> </tbody> </table>	D	C	B	A	ENABLE	W	X	X	X	X	H	H	L	L	L	L	L	E0	L	L	L	H	L	E1	L	L	H	L	L	E2	L	L	H	H	L	E3	L	H	L	L	L	E4	L	H	L	H	L	E5	L	H	H	L	L	E6	L	H	H	H	L	E7	H	L	L	L	L	E8	H	L	L	H	L	E9	H	L	H	L	L	E10	H	L	H	H	L	E11	H	H	L	L	L	E12	H	H	L	H	L	E13	H	H	H	L	L	E14	H	H	H	H	L	E15
D	C	B	A	ENABLE	W																																																																																																											
X	X	X	X	H	H																																																																																																											
L	L	L	L	L	E0																																																																																																											
L	L	L	H	L	E1																																																																																																											
L	L	H	L	L	E2																																																																																																											
L	L	H	H	L	E3																																																																																																											
L	H	L	L	L	E4																																																																																																											
L	H	L	H	L	E5																																																																																																											
L	H	H	L	L	E6																																																																																																											
L	H	H	H	L	E7																																																																																																											
H	L	L	L	L	E8																																																																																																											
H	L	L	H	L	E9																																																																																																											
H	L	H	L	L	E10																																																																																																											
H	L	H	H	L	E11																																																																																																											
H	H	L	L	L	E12																																																																																																											
H	H	L	H	L	E13																																																																																																											
H	H	H	L	L	E14																																																																																																											
H	H	H	H	L	E15																																																																																																											
21	A7U7 A8U1 thru U11, U18	1816-0039 1816-0130 thru 1816-0141	Same Same	<p>Read Only Memory (All units have different bit pattern)</p>  <p>Outputs are Low True. All outputs are High (false) if EN1 or EN2 is High.</p>																																																																																																												

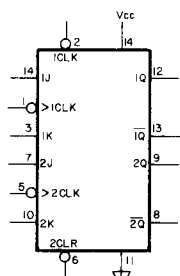
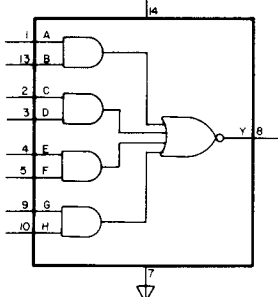
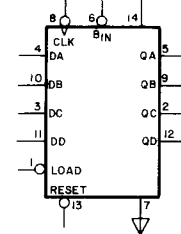
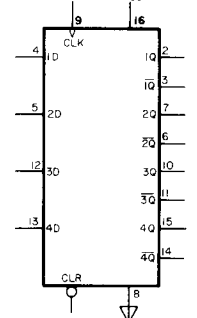
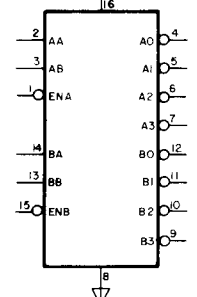
Table 7-4. Mnemonic Dictionary of Instructions and Qualifiers.

Mnemonic	Description	Source	Assembly
AL2, AL1, AL0	These instructions control the following functions performed by the Arithmetic and Logic Unit (A7U7).	ROM U2	A8
Function			
NOP	No operation		
IOR	Inclusive OR		
XOR	Exclusive OR		
R-S	Full Subtractor		
ADD	Full Adder		
S-R	Full Subtractor		
EQ	Equal		
IOR-CCY	Inclusive OR and Clear Carry		
ATR	Transfers the least significant bit of the A register to the R Bus. The data is recirculated in the A register in the absence of a TTA instruction.	ROM U10	A8
C3, C2, C1, C0	Control the number of each register clock pulses given in each control state.	ROM U11	A8
CHF	Conditional Halt Flag. During a sweep, indicates that the last key input was a preface key. Should a numeric key follow, control will effect a halt and start the numeric entry routine.	U4	A7
CLF	Clears input flag.	$\overline{G1} \overline{G0} \overline{D2} \overline{D1} \overline{D0}$	A8
CLS	Clears sweep flag.	$\overline{G1} \overline{G0} \overline{D2} \overline{D1} \overline{D0}$	A8
CPF	Clock pulse to numeric and conditional halt flags.	$\overline{IT2} \overline{IT1} \overline{IT0}$	A8
CY	Output of Carry Flip-Flop.	A7U8 (12)	A7
ER	Error Flag. Indicates that some operation has attempted to send the instrument out of range. Control will detect the condition and refuse to perform the operation.	U18	A6
ETR	Transfers the Extend bit to the R Bus.	$\overline{G3} \overline{G2} F3$	A8
EX	Output of Extend Flip-Flop.	A7U8 (9)	A7
FLA	Flag A. In CW mode of operation, indicates that the last key input was a preface key (in preparation for a numeric entry). During a sweep, indicates a mid-sweep interrupt condition.	$F3 \overline{F2} \overline{G3} \overline{G2}$	A8

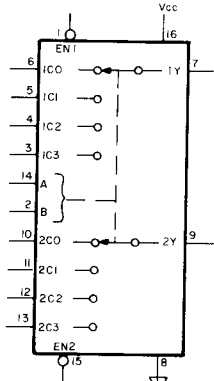
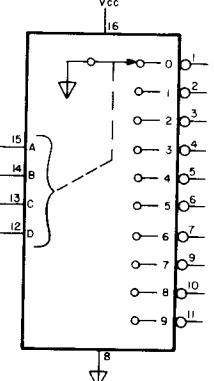
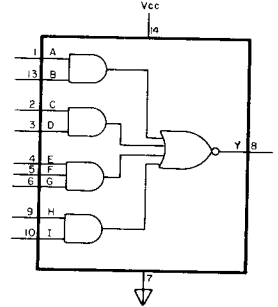
Table 7-4. Mnemonic Dictionary of Instructions and Qualifiers (Cont'd).

Mnemonic	Description	Source	Assembly
FLB	Flag B. During numeric entry, indicates that a decimal key has been struck. During sweep operation, indicates that this is a single sweep. If Flag A is low and Flag B is high, the last operation was either a "first point" calculation or a single sweep.	F1 $\overline{F0}$ G3 $\overline{G2}$	A8
FLAG	Input Flag. Indicates to control that there is data at the input which needs to be processed.	U4	A6
FREQ	Indicates that the operation in process is a frequency operation.	$\overline{Q0}$	A7
GT	Parallel loads the D instructions into the M register.	$\overline{G1}$ $\overline{G0}$	A8
IQM	Inhibits all instructions except LAA if the qualifier is met (1).	ROM U4	A8
IQN	Inhibits all instructions except LAA if the qualifier is not met (0).	ROM U4	A8
IST	FREQ SW UP + AMP SW UP		A8
ISW	Parallel loads the slide switch information into the Q register.	G1 $\overline{G0}$ $\overline{D2}$ $\overline{D1}$ $\overline{D0}$	A8
ITS	Transfers the input register to the S Bus. The input data is recirculated.	G1 $\overline{G0}$ $\overline{D2}$ $\overline{D1}$ $\overline{D0}$	A8
JFA	Sets Flag A	$\overline{G3}$ G2 F3 $\overline{F2}$	A8
JFB	Sets Flag B	$\overline{G3}$ G2 F1 $\overline{F0}$	A8
KFA	Clears Flag A	$\overline{G3}$ G2 $\overline{F3}$ F2	A8
KFB	Clears Flag B	$\overline{G3}$ G2 $\overline{F1}$ F0	A8
KTR	Transfers the least significant bit of the K Register to the R Bus. The data is recirculated.	$\overline{G3}$ $\overline{G2}$ F1	A8
LAA	Loads a stored alternate address into the address flip-flops. This instruction is not inhibited by IQM or IQN.	ROM U4	A8
LAC	Parallel loads a constant into the A register, which is used to determine the amplitude setting and display.	G1 $\overline{G0}$ $\overline{D2}$ $\overline{D1}$ $\overline{D0}$	A8
LK	Parallel loads the four D instructions into the K register.	IT2 $\overline{IT1}$ IT0	A8
LLC	Serial loads information from the T Bus into the leveling control register.	IT2 IT1 $\overline{IT0}$	A8
NUM	Numeric Flag. Indicates that a numeric entry is in process. If any key other than a numeric or decimal key is struck, control will effect a halt.	F1 $\overline{IT2}$ $\overline{IT1}$ $\overline{IT0}$	A8
OTAC	Causes the T Bus to be transferred to the output register. The 0 to 1 transition latches the sixteen most significant bits of the output register into the amplitude control register.	$\overline{G1}$ $\overline{G0}$ P3 $\overline{D1}$ $\overline{D0}$	A8
OTAD	Causes the T Bus to be transferred to the output register and enables the amplitude display.	$\overline{G1}$ $\overline{G0}$ P3 D1 $\overline{D0}$	A8
OTC	Transfer output register to control register (amplitude or frequency).		

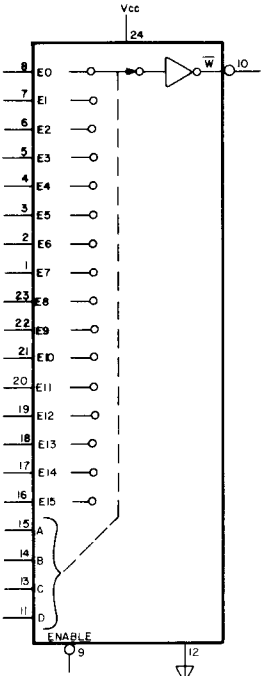
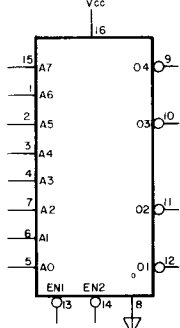
Table 7-4. Mnemonic Dictionary of Instructions and Qualifiers (Cont'd).

Mnemonic	Description	Source	Assembly
OTD	Transfer Output register to display (amplitude or frequency).		
OTDL	Causes the T Bus to be transferred to the output register and latches the eight most significant bits of the output register into the decimal register.	$\overline{G1} G0 D1 D0$	A8
OTFC	Causes the T Bus to be transferred to the output register. The 1 to 0 edge of the next TTQ instruction will cause the information in the output register to be latched into the sweep generator register.	$\overline{G1} G0 \overline{P3} \overline{D1} \overline{D0}$	A8
OTFD	Causes the T Bus to be transferred to the output register and enables the frequency display.	$\overline{G1} G0 \overline{P3} \overline{D1} D0$	A8
OTHG	Causes the T Bus to be transferred to the output register. The 0 to 1 edge causes the output register bits 030 through 017 to be latched into the sweep generator register.	$\overline{G1} G0 D1 \overline{D0}$	A8
P0	Least significant bit of the P register. Used to indicate to control that the operation in process is on either a frequency or amplitude step.	U25	A7
P3	Most significant bit of the P register. Used to indicate to control that the operation in process is on amplitude.	U25	A7
PTR	Transfers the least significant bit of the P register to the R Bus. In the absence of TTP, the data is recirculated.	$\overline{G3} \overline{G2} F2$	A8
Q0 thru Q5	Q Register outputs. Used as qualifiers to the ROM for a number of operations.	U30	A7
QTS	Transfers the least significant bit of the Q register to the S Bus. The data is not recirculated in the Q register.	ROM U1	A8
RCHF	Clears the conditional halt flag. Clock to the flag is the CPF instruction.	$\overline{F3} \overline{IT2} \overline{IT1} \overline{IT0}$	A8
RDM	Read Memory. Transfers the least significant bit of the memory to the S Bus. Memory register is controlled by the contents of the M Register. In the absence of a WTM instruction the data is recirculated.	ROM U1	A8
RDY	Indicates to control that the sweep step timer is ready to begin a sweep step.	Timer Holdoff and Timer Output	A7
RNUM	Clears the numeric flag. Clock to the flag is the CPF instruction.	$\overline{F1} \overline{IT2} \overline{IT1} \overline{IT0}$	A8
R1 R0	Used during arithmetic and shifting subroutines to steer control through the proper routine. Arithmetic Register Shifting R1 R0 R0 0 0 Add 0 Register Right Shift 0 1 Special Add 1 Register Left Shift 1 0 S-R 1 1 R-S	RA7 RA6 Clocked by SAA	A8
SAA	Stores an alternate address to be used as a return from a subroutine. The four bits latched are controlled by the F instructions. The two most significant bits of the address are also stored to steer the arithmetic and register shifting subroutines.	$G3 \overline{G2}$	A8

Table 7-4. Mnemonic Dictionary of Instructions and Qualifiers (Cont'd).

Mnemonic	Description	Source	Assembly
SART	Arithmetic subroutine.		
SCHF	Sets the conditional halt flag. Clock to the flag is the CPF instruction.	F3 $\overline{IT2}$ $\overline{IT1}$ $\overline{IT0}$	A8
SNUM	Sets the numeric flag. Clock to the flag is the CPF instruction.	F1 $\overline{IT2}$ $\overline{IT1}$ $\overline{IT0}$	A8
SRLS	Register Left Shift subroutine.		
SRRS	Register Right Shift subroutine.		
STE	Sets the error flag.	G1 $\overline{G0}$ $\overline{D2}$ D1 D0	A8
STS	Sets the sweep flag.	$\overline{G2}$ $\overline{G3}$ F0	A8
STT	Starts the timer.	G1 $\overline{G0}$ D2 $\overline{D1}$ D0	A8
STTF	Stores in the timer latch the three most significant bits and the least significant bit of the Q register. The three most significant bits control the time per step and the least significant bit stores the sweep mode (amplitude or frequency). This instruction also clocks the sweep up flag.	G1 $\overline{G0}$ D2 $\overline{D1}$ $\overline{D0}$	A8
SWF	Switch flag. Indicates that a front panel slide switch has been moved. SWF is also set during start up or if the instrument is switched from remote to local control.	U1	A2
SWP	Sweep flag. Indicates that a sweep is in process.	U19	A6
SW UP or SU	Sweep up flag. Controls sweep direction, or end point setting of the sweep generator when the instrument is not sweeping.	U12	A8
TMS	Transfers the least significant bit of the M register to the S Bus and the T Bus is transferred to the most significant bit of the M register.	ROM U1	A8
TTA	Transfers the T Bus to the most significant bit of the A register.	$\overline{IT2}$ $\overline{IT1}$ $\overline{IT0}$	A8
TTE	Transfers the T Bus to the Extend flip-flop.	$\overline{IT2}$ $\overline{IT1}$ $\overline{IT0}$	A8
TTO	Transfers the T Bus to the Output register.	$\overline{G1}$ G0	A8
TTP	Transfers the T Bus to the most significant bit of the P register.	$\overline{IT2}$ $\overline{IT1}$ $\overline{IT0}$	A8
TTQ	Transfers the T Bus to the most significant bit of the Q register.	IT2 $\overline{IT1}$ $\overline{IT0}$	A8
UTR	Forces the R Bus to a 1.	ROM U2	A8
WTM	Write memory. Transfers the T Bus to the most significant bit of the memory. Memory register being written into is controlled by the contents of the M register.	ROM U1	A8
L-1000	Indicates the end of a sweep.	Sweep generator	A19

**Table 7-5. ROM Bit Lists.
A7U7 ALU**

	04 (Not Used)	03 = T Bus	02 = Carry J } To Carry	01 = Carry K } Flip-Flop					
000-007	HLLL	HLLL	HLLL	HLLL	HLLL	HLLL	HLLL	HLLL	HLLL
010-017	HLLL	HHLL	HHLL	HHHL	HHLL	HHLL	HLHL	HHLL	HHLL
020-027	HLLL	HHLL	HHLL	HHLL	HHLL	HHHL	HLHL	HHLL	HHLL
030-037	HLLL	HHLL	HLLL	HLLL	HLHL	HLLL	HLLL	HLLL	HHLL
040-047	HLLL	HLLL	HLLL	HHLL	HHLL	HHLL	HLLL	HLLL	HHLL
050-057	HLLL	HHLL	HHLL	HLLL	HLLL	HLLL	HHLL	HLLL	HHLL
060-067	HLLL	HHLL	HHLL	HLLH	HLLL	HLLL	HLLL	HLLL	HHLL
070-077	HLLL	HHLL	HLLL	HHLL	HHLL	HHLL	HLLL	HLLL	HHLL
100-107	HLLL	HHLL	HHLL	HHLL	HHLL	HHHL	HLHL	HHLL	HHLL
110-117	HLLL	HHLL	HLLL	HLLL	HLHL	HLLL	HLLL	HHLL	HHLL
120-127	HLLL	HHLL	HHLL	HHLL	HHLL	HHHL	HLHL	HHLL	HHLL
130-137	HLLL	HHLL	HLLL	HLLL	HLHL	HLLL	HLLL	HHLL	HHLL
140-147	HLLL	HHLL	HHLL	HLLH	HLLL	HLLL	HLLL	HHLL	HHLL
150-157	HLLL	HHLL	HLLL	HHLL	HHLL	HHLL	HLLL	HHLL	HHLL
160-167	HLLL	HHLL	HHLL	HLLH	HLLL	HLLL	HLLL	HHLL	HHLL
170-177	HLLL	HHLL	HLLL	HHLL	HHLL	HHLL	HLLL	HHLL	HHLL

Address Inputs
 Bit
 7 = UTR
 6 = Ground (0)
 5 = CY
 4 = R Bus
 3 = S Bus
 2 = AL2
 1 = AL1
 0 = AL2

Table 7-5. ROM Bit Lists (Cont'd).
A8U1.

000	HHHH	001	HHHH	002	HHLH	003	HHHH	004	LLHH
005	HHLH	006	HHLH	007	HHLH	010	HHHH	011	HHHH
012	HHHH	013	LHHH	014	HHLH	015	HLHH	016	HHHH
017	HHHH	020	HHHH	021	HHHH	022	HHHH	023	HLHH
024	HHHH	025	HHLH	026	HHHH	027	HLHH	030	LHHH
031	HHLH	032	HHHH	033	HHHH	034	HHLH	035	HHLH
036	HHHH	037	HHHH	040	HHHH	041	HHHH	042	HHHH
043	LHHH	044	LLHH	045	LHHH	046	HHHH	047	LHHH
050	HHHH	051	HHHH	052	LHHH	053	HHHH	054	HHHH
055	HHHH	056	LHHH	057	LHHH	060	LLHH	061	LHHH
062	LLHH	063	HHHH	064	HHHH	065	LHHH	066	HHHH
067	HHLH	070	HLHH	071	HHHH	072	HHHH	073	HHHH
074	LHHH	075	HHHH	076	HHHH	077	HHHH	100	HHHH
101	HHHH	102	HHHH	103	LHHH	104	LHHH	105	LHHH
106	HHHH	107	LHHH	110	LHHH	111	HHHH	112	HHHH
113	HHHH	114	HHHH	115	LHHH	116	LHHH	117	HLHH
120	LHHH	121	HHLH	122	HHHH	123	HHHH	124	HHHH
125	HHHH	126	HHHH	127	HHLH	130	HHHH	131	HHHH
132	HLHH	133	HHHH	134	HLHH	135	LHHH	136	HHHH
137	HHHH	140	HHHL	141	HHHH	142	LHHH	143	HHHH
144	LHHH	145	HHHH	146	HHHH	147	HHHH	150	HHHH
151	HHHH	152	HHHH	153	HHHH	154	HLHH	155	HHHH
156	HHHH	157	HHHH	160	HHHH	161	LHHH	162	LHHH
163	HHHH	164	HHHH	165	LHHH	166	HHHH	167	HHHH
170	HHHH	171	LHHH	172	HHHH	173	HLHH	174	HHHH
175	HHHL	176	HHHH	177	HHHH	200	HHHH	201	HHHH
202	HHHH	203	HHHH	204	HHHH	205	HHHH	206	LLHH
207	LHHH	210	HHHH	211	HHHH	212	HLHH	213	HLHL
214	LHHH	215	HHHH	216	HHHH	217	HHHH	220	HHHH
221	HHHH	222	HHHH	223	HHHH	224	HHHH	225	LHHH
226	HLHH	227	HHHH	230	LHHH	231	LHHH	232	HHHL
233	LHHH	234	HLHH	235	HHHH	236	HLHH	237	LHHH
240	LHHH	241	HHHH	242	HHHH	243	HHHH	244	HHLH
245	HHHH	246	LHHH	247	HHHH	250	HHHH	251	HHHH
252	HLHH	253	HHHH	254	HLHH	255	HHHH	256	HLHH
257	HHHH	260	HHHH	261	LHHH	262	LHHH	263	HHHH
264	HHHH	265	LHHH	266	HHHH	267	LHHH	270	LHHH
271	HHHH	272	LHHH	273	HHHH	274	LHHH	275	HHLH
276	LHHH	277	HHHH	300	HHHH	301	HHHH	302	HHHH
303	HHHH	304	LHHH	305	HHHH	306	HHLH	307	HHLH
310	HHHH	311	LHHH	312	HHHH	313	LLHH	314	HHHH
315	HHHH	316	LHHH	317	HHHH	320	LHHH	321	HHHH
322	HHHH	323	HHHH	324	HHHH	325	LHHH	326	HHHH
327	HHHH	330	LHHH	331	HHHH	332	HLHH	333	HHHH
334	HHHH	335	HHHH	336	HHHH	337	HHHH	340	HLHH
341	HHHH	342	LHHH	343	HHHH	344	HHHL	345	HHHH
346	HHHH	347	LHHH	350	HHHH	351	HHHH	352	HHHH
353	LLHH	354	HHHH	355	HHLH	356	LHHH	357	HHHH
360	HHHH	361	HHHH	362	HHHH	363	LHHH	364	LHHH
365	HHHH	366	HHHH	367	HHHH	370	HLHH	371	HHHH
372	HHHH	373	LHHH	374	HHHH	375	HHHH	376	LHHH
377	LHHH								

Table 7-5. ROM Bit Lists (Cont'd).
A8U2

000	LLHL	001	HHHH	002	LHLL	003	HHLH	004	LHHH
005	LHLL	006	HHLH	007	LHLL	010	HHHH	011	HHHH
012	HHHH	013	HHLH	014	HHLH	015	HHLH	016	HHHH
017	HHHH	020	HLLH	021	HHHH	022	HLLH	023	HHLH
024	HHHH	025	LHHH	026	HHHH	027	LLLH	030	HHLH
031	HHHH	032	LLH	033	HLLH	034	HHHH	035	HHLH
036	LLLH	037	HHHH	040	HHHH	041	LLHL	042	LLLH
043	HHLH	044	HLLH	045	HHLH	046	HHHH	047	HHHH
050	LLLH	051	HHHH	052	HHLH	053	HHHH	054	HHHH
055	HHHH	056	HHHH	057	LLHH	060	LHHH	061	LLLH
062	LHLH	063	HHHH	064	HHHH	065	HHLH	066	HHHH
067	HHLH	070	LHHH	071	LLLH	072	HHHH	073	HHHH
074	HHLH	075	HHHH	076	HHHH	077	LLLH	100	HHHH
101	HHHH	102	HHHH	103	HHHH	014	HHHH	105	HHHH
106	HHHH	107	HHLH	110	HHLH	111	HHLH	112	HHHH
113	HHHH	114	HLLH	115	HHLH	116	LLHL	117	HHLH
120	HHHH	121	HLLH	122	LLLH	123	HHHH	124	HHHH
125	LLHL	126	HHHH	127	LLLH	130	HHHH	131	HHHH
132	HHHH	133	HHHH	134	HHLH	135	LLLH	136	HHLH
137	HHHH	140	HHLH	141	HHHH	142	HHHH	143	HHHH
144	LHHH	145	HHHH	146	HHHH	147	HHHH	150	HHHH
151	LLHL	152	HHHH	153	HLLH	154	HHLH	155	LLLH
156	HHHH	157	HHHH	160	HLLH	161	LHLH	162	HHHH
163	HHHH	164	HHHH	165	HHLH	166	HHHH	167	HHHH
170	LLLH	171	HHLH	172	HHHH	173	HHHH	174	HHHH
175	LLHL	176	HHHH	177	HHHH	200	HHHH	201	HHHH
202	HHHH	203	HHHH	204	HHHH	205	HHHH	206	LLHH
207	HHLH	210	HHHH	211	LLLL	212	HHLH	213	LLLH
214	HHLH	215	HHHH	216	HHHH	217	HHHH	220	HHHH
221	HHHH	222	HHHH	223	HHHH	224	LLHL	225	LLHH
226	HHLH	227	HHHH	230	HHHH	231	HHLH	232	HHLH
233	HHHH	234	HHLH	235	HHHH	236	HHLH	237	HHHH
240	LLHH	241	HHHH	242	LHHH	243	LLLL	244	HHLH
245	LLLH	246	LLHH	247	HHHH	250	HHHH	251	HHHH
252	HHLH	253	HHHH	254	HHLH	255	HHLH	256	LHHH
257	HHHH	260	HHHH	261	LLHH	262	HHHH	263	HHHH
264	HHHH	265	HLLH	266	HHHH	267	LLLH	270	HHHH
271	HHLH	272	LHLH	273	HHHH	274	HHHH	275	HHLH
276	HLLH	277	HHHH	300	HHHH	301	HHLH	302	HHHH
303	HHHH	304	HHHH	305	HHHH	306	LHLL	307	LLLH
310	HHHH	311	LLHH	312	HHHH	313	LHHH	314	HHHH
315	HHHH	316	LLHH	317	LHHH	320	HLLH	321	HHHH
322	HHHH	323	HHHH	324	HHHH	325	HHLH	326	LLHL
327	HHHH	330	HHLH	331	HHHH	332	HHLH	333	LLHH
334	HHHH	335	LLHL	336	LLLH	337	HHHH	340	LLLH
341	LLLH	342	HHHH	343	HHHH	344	HHHH	345	LLHL
346	HHHH	347	HHLH	350	HHHH	351	LLHH	352	HHHH
353	LLHH	354	LLHL	355	LHHL	356	HHLH	357	LHHH
360	HHHH	361	HHHH	362	LLHL	363	HHLH	364	HHHH
365	HHHH	366	HHHH	367	HHHH	370	HHHH	371	LLHH
372	HHHH	373	HHHH	374	HLLH	375	HHHH	376	HHLH
377	HLLH								

Table 7-5. ROM Bit Lists (Cont'd).
A8U3

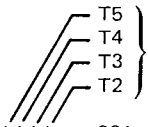
									
000	LLLL	001	LLHH	002	HHLH	003	LHHL	004	LLLL
005	HHLH	006	HLLH	007	HHHL	010	LLLL	011	HHHL
012	LLLL	013	HHLH	014	HLLH	015	LLLL	016	LHLL
017	LLLL	020	LHLH	021	HLLL	022	LLLL	023	LLHH
024	LLHL	025	HHLH	026	LLLL	027	LLLL	030	HHHL
031	HHHL	032	LHHL	033	LLLL	034	LLHH	035	LLLL
036	HHHL	037	LLLL	040	HHHH	041	LLHH	042	HLLL
043	LHHL	044	LLLL	045	HHHL	046	HHHL	047	LLLL
050	LLHL	051	HLHL	052	HHLH	053	HHLH	054	HHLH
055	HHLH	056	LLLL	057	HHHL	060	HHLH	061	LLLL
062	HHLL	063	LLLL	064	LLLL	065	LLLL	066	LLHH
067	LHLL	070	LLLL	071	HHHH	072	HLLL	073	LLLL
074	HHLH	075	LLLL	076	HHLH	077	LLLL	100	HHLH
101	HLLL	102	LHLH	103	LLLL	104	LLLL	105	LLLL
106	LLLL	107	LLLL	110	LLLL	111	LLLL	112	LLHH
113	LLLL	114	HLLH	115	HHLH	116	LLLL	117	LLLL
120	LHLL	121	LLLL	122	LHLL	123	LHLL	124	HHLH
125	LLHH	126	LLLL	127	LLLL	130	LLLL	131	LLLL
132	LLLL	133	HHLH	134	LHLL	135	LHLL	136	LHLL
137	HHLL	140	LLLL	141	LHLH	142	LHLH	143	LLLL
144	HHHL	145	LHLH	146	LHLL	147	LLLL	150	HHLH
151	LLLL	152	LHLL	153	HHLL	154	LLLL	155	LLLL
156	HHLH	157	LHLH	160	LHLH	161	HHHL	162	LHLH
163	LHLL	164	LHHL	165	HLLL	166	LLHL	167	LLLL
170	HHHL	171	HLHL	172	LLLL	173	LLLL	174	HLLL
175	LLLL	176	LHLL	177	LLLL	200	LLLL	201	LLHH
202	HLLH	203	HHLH	204	LLHL	205	LLLL	206	LHLL
207	LLLL	210	HLLH	211	LLLL	212	LLLL	213	HLLH
214	LLLL	215	HHHL	216	LLLL	217	HHHL	220	HLLL
221	LLLL	222	LHHL	223	LLLL	224	LLLL	225	HHLH
226	LLHH	227	HHLH	230	LHLH	231	LLLL	232	LLLL
233	LHLH	234	LLLL	235	LLHL	236	HHHL	237	HHLL
240	HHHL	241	LLLL	242	LLLL	243	LLLL	244	LLLL
245	HHLH	246	LLLL	247	HHLH	250	LLHH	251	HLLL
252	LLLL	253	HHLH	254	HLHL	255	LLLL	256	LLLL
257	HHHL	260	LHLL	261	HHHL	262	HHHL	263	HLLL
264	LLHH	265	HHHL	266	LLLL	267	LLLL	270	LHLL
271	LLLL	272	HHHL	273	HLLL	274	LLLL	275	LLLL
276	LLLL	277	LLLL	300	HLLL	301	HHHL	302	LHLL
303	LHLL	304	LLLL	305	LLLL	306	LLLL	307	LLLL
310	LHLL	311	HHLH	312	HHLH	313	LLLL	314	LHLH
315	HHLH	316	LLLL	317	HHHL	320	LHLH	321	LHLH
322	LHLL	323	LHLL	324	HLLH	325	LHHL	326	HHLH
327	HLHL	330	LLLL	331	HHHL	332	LLLL	333	HHHL
334	HHLH	335	HHLH	336	LHLL	337	LLLL	340	LHLL
341	LLLL	342	LHLH	343	LLHH	344	HHHL	345	HHHL
346	LHLH	347	LLHH	350	LLLL	351	HHHL	352	LLLL
353	LLLL	354	LLHH	355	HHLL	356	HHHL	357	LLLL
360	LHLL	361	LLHH	362	HLLL	363	HLLL	364	HHHL
365	LHLH	366	LHLL	367	LLLL	370	LLLL	371	HHHL
372	LLLL	373	HHHL	374	LLLL	375	LHLH	376	LHLL
377	LLLL								

**Table 7-5. ROM Bit Lists (Cont'd).
A8U4**

		TI Qualifier Select								
		IQN	IQM	LAA	Inhibit					
000	LLLL	001	LLLL	002	HLHL	003	LLLL	004	LLLL	
005	HLHL	006	HLHL	007	LLLL	010	LLLH	011	LHLL	
012	LLLL	013	LLLL	014	LLHL	015	LLLL	016	LLLL	
017	LLLL	020	LLLL	021	HLHL	022	LLLL	023	LLLL	
024	HLLL	025	HLLL	026	LLLL	027	LLLL	030	LLLL	
031	LLLL	032	HLLL	033	LLLL	034	LLHL	035	LLLL	
036	HLHL	037	LLLL	040	HLHL	041	LLHL	042	LLLL	
043	LLLL	044	LLLL	045	LLLL	046	LHLL	047	LLLL	
050	LLLL	051	LLHL	052	LHLL	053	HLHL	054	HLLL	
055	LLLL	056	LLLH	057	HHLL	060	HLHL	061	LLLL	
062	LLHL	063	HLLL	064	LLLL	065	LLLL	066	HHLL	
067	LLLL	070	LLLL	071	LHLL	072	HLLL	073	LLLL	
074	HHLL	075	LLLL	076	LLHL	077	LLLL	100	LHLL	
101	LLLL	102	HLHL	103	LLLL	104	LLLL	105	LLLL	
106	LLLL	107	LLLL	110	LLLL	111	LLLL	112	LLHL	
113	LLLL	114	LLHL	115	HLLL	116	LLLL	117	LLLL	
120	LLHL	121	LLLL	122	LHLL	123	LHLL	124	HHLL	
125	LLLL	126	LLLL	127	LLLL	130	LLLL	131	LLLL	
132	LLLH	133	HLHL	134	HHLL	135	LLHL	136	HHLL	
137	LHLL	140	LLLL	141	HHLL	142	LHLL	143	LLLL	
144	LLLL	145	HHLL	146	HLHH	147	LLLH	150	HLLL	
151	LLLL	152	HLLL	153	HHLL	154	LLLL	155	LLLL	
156	HLLL	157	LLLL	160	LLLL	161	LLLL	162	LLHL	
163	HLLL	164	LLLL	165	HLLL	166	HLLL	167	LLLH	
170	HLLL	171	LHLL	172	LLLL	173	LLLH	174	LLHL	
175	LLLL	176	LLLL	177	LLLH	200	LLLL	201	LLLL	
202	LLLL	203	HLLL	204	LLLL	205	LLLL	206	HLHL	
207	LLLL	210	LLHL	211	LLLL	212	LLLL	213	LLLL	
214	LLLH	215	LHLL	216	LLLH	217	LLLL	220	LLLL	
221	LLLL	222	LHLL	223	LLLL	224	LLLL	225	LHLL	
226	HLLL	227	HLLL	230	LHLL	231	LLLL	232	LLLL	
233	HLHL	234	LLLL	235	LLLL	236	LLHL	237	LHLL	
240	LLLL	241	HLLL	242	LLLL	243	LLLL	244	LLLL	
245	HLHH	246	LLLL	247	HLLL	250	HLLL	251	HLLL	
252	LLLH	253	HLHL	254	LHLL	255	LLLL	256	LLLL	
257	LHLL	260	HHLL	261	LLLL	262	LLHL	263	HLHL	
264	HLLL	265	LLLL	266	LLLL	267	LLLL	270	HHLL	
271	LLLL	272	LLLL	273	HLLL	274	LLLL	275	LLLL	
276	LLLL	277	LLLL	300	LLHL	301	LHLL	302	LHLL	
303	HHLL	304	LLLL	305	LLLL	306	LLLL	307	LLLL	
310	HHLL	311	HLLL	312	LLLL	313	LLLL	314	LLHL	
315	HLLL	316	LLLL	317	LLLL	320	LHLL	321	HLLL	
322	LLHL	323	HHLL	324	HLLL	325	HLLL	326	HLLL	
327	LLLL	330	LLLL	331	LLHL	332	LLLL	333	LLLL	
334	LLLL	335	LLHL	336	LHLL	337	LLLL	340	LLHL	
341	LLLL	342	HLHL	343	LHLL	344	LLLL	345	HLLL	
346	LLHL	347	LLLL	350	LLLL	351	LLLL	352	LLLL	
353	LLLL	354	HLLL	355	LLHL	356	LLHL	357	LLLL	
360	HLLL	361	HLLL	362	LLHL	363	LLLL	364	LHLL	
365	LHLL	366	LLLL	367	LLLL	370	LLLL	371	LLLL	
372	LLLL	373	LHLL	374	LLLL	375	LHLL	376	HLLL	
377	LLLL									

Table 7-5. ROM Bit Lists (Cont'd).
A8U5

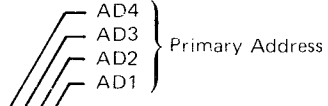
									
000	LLLL	001	HLLL	002	HLLL	003	LLHL	004	LHLL
005	LHLH	006	LLHH	007	LHHH	010	HHLL	011	LLHH
012	HLHH	013	HHLH	014	HLLL	015	LLHH	016	LLHH
017	HHHH	020	LHHL	021	HLHH	022	LLLL	023	LLHL
024	HHHH	025	LHHL	026	HHLL	027	LHHH	030	LLHL
031	LHLH	032	LLHL	033	LHLH	034	LLH	035	HHLL
036	LHLH	037	HHHH	040	LLHH	041	LLH	042	HLLL
043	LLHH	044	LHLL	045	LHLH	046	HHHH	047	HLHL
050	LLLL	051	HHLL	052	HLLH	053	LHLH	054	LHHH
055	HHLH	056	HLHH	057	HHHH	060	LLHL	061	LLHH
062	LHLL	063	LLHH	064	HHHH	065	HHHH	066	LHLL
067	HHHH	070	LLHH	071	LLH	072	HHLL	073	LHLH
074	HLHL	075	LLHL	076	HHLH	077	LLHL	100	HLLL
101	HLHH	102	LLHL	103	LLHH	104	HLHL	105	LHHH
106	LHHH	107	LHHH	110	LLLL	111	HHLL	112	LLHH
113	LHHH	114	LLHH	115	HLLL	116	LHLH	117	HHLL
120	LLLL	121	LLH	122	HLLL	123	HLLL	124	LHLH
125	HLHH	126	LLLL	127	LHLH	130	LLHL	131	HHLL
132	HLHL	133	HHLL	134	LLHH	135	LLHL	136	LHHH
137	HLLL	140	LHHL	141	LLLL	142	HHLL	143	LLHH
144	LHLL	145	LHLH	146	LHHL	147	LHHH	150	LLH
151	HLHH	152	HHHL	153	HHHH	154	HLLH	155	HHHH
156	HHLH	157	LHLH	160	LLLL	161	LLH	162	HHLL
163	LLHH	164	LHHL	165	LHHH	166	HHHH	167	LHHH
170	LLH	171	LHLL	172	HLHL	173	HLHL	174	HLHL
175	HHLH	176	HHLH	177	HLLH	200	LLHL	201	LLH
202	LLHH	203	LHHH	204	HHHH	205	HHHL	206	HHHL
207	LHHH	210	LHHH	211	HHHL	212	HHHH	213	HHLL
214	LHLL	215	HHLH	216	HHHL	217	HHHH	220	LLHL
221	LLH	222	LLLL	223	HLLL	224	LHLL	225	HHHL
226	HHLH	227	HLHH	230	HLLL	231	HHLH	232	HLHL
233	LLHH	234	HHHL	235	HLHL	236	HLLH	237	HHHL
240	LLHH	241	HLHL	242	LHHH	243	HHLL	244	LHLL
245	HLHH	246	LHHL	247	HLHH	250	HHLL	251	HHLL
252	HLLL	253	HHHH	254	HHLL	255	HLHL	256	HHHL
257	HHHH	260	LLHL	261	LHHL	262	LHLL	263	LLLL
264	LLH	265	LHLH	266	LHHL	267	LHHL	270	HLLL
271	HLLL	272	HHHH	273	LHHH	274	LLH	275	LLHL
276	LHLH	277	HHHH	300	HLLH	301	LLH	302	HLLL
303	LLHL	304	LHHL	305	LLH	306	LHLH	307	LHLH
310	LHLH	311	HHHL	312	HLHL	313	HLHH	314	HHHH
315	HHLL	316	HHHL	317	HHHH	320	LHHL	321	LHHL
322	LHLH	323	HHHL	324	LLHH	325	HLHL	326	HHHL
327	LLHH	330	HHLH	331	LHLH	332	HLHL	333	HHHL
334	HHLL	335	HLHH	336	HLLH	337	HHHH	340	HLLL
341	LHLL	342	HHLH	343	LLH	344	LLHH	345	LHLH
346	LHLL	347	HLLL	350	HLHL	351	LHLH	352	HLHL
353	HLHH	354	LLH	355	LHHL	356	HHHL	357	HHHH
360	LLLL	361	LLH	362	LLHH	363	HHLL	364	LHLL
365	LHLH	366	HLHH	367	HHHH	370	HHHL	371	LHLH
372	HLHL	373	HLHH	374	HHLL	375	HHHL	376	LHHH
377	HHHH								

**Table 7-5. ROM Bit Lists (Cont'd).
A8U6**

											
000	HLLL	001	HHHH	002	HHHH	003	HHHL	004	LLHH		
005	HHHH	006	HLHL	007	HHHH	010	HLLL	011	HLHL		
012	HHHL	013	HHLH	014	LLHH	015	HHHL	016	LHHL		
017	HLHH	020	HLHH	021	HLHL	022	HHHH	023	LLHH		
024	HLLL	025	LLHH	026	HLLL	027	HHLH	030	HHLH		
031	HLHL	032	HHHL	033	LHLL	034	HHLH	035	HHHL		
036	HLLL	037	HLHL	040	HLLL	041	HLLL	042	LLHH		
043	HHHL	044	HHHH	045	HHHL	046	HLHL	047	HHHH		
050	HLLL	051	HHHL	052	HHHL	053	HLLL	054	LHLL		
055	HLLL	056	HHHH	057	HHHH	060	HHHH	061	HHHH		
062	HHHH	063	LHLL	064	HLLL	065	HLHH	066	HLLL		
067	HLHH	070	HLHH	071	HHHH	072	HLLL	073	LHLL		
074	HLHH	075	HLLL	076	HLLL	077	HHHH	100	HLLL		
101	HLHL	102	HHHL	103	HHHH	104	HHHH	105	HHHH		
106	HHHH	107	HHHH	110	HLLL	111	HLLL	112	LHHH		
113	HLLL	114	HLHL	115	HLLH	116	HHHH	117	LLHL		
120	LHHH	121	LLLH	122	HHHH	123	LLHH	124	HLLL		
125	HLLL	126	HHHH	127	LHLL	130	HHLH	131	LHHL		
132	HHHH	133	HLLL	134	HHHH	135	HHLH	136	HHHH		
137	HLLL	140	HHHH	141	HLLL	142	HHHH	143	HHHH		
144	LLHH	145	HLLL	146	HLLL	147	HLLL	150	HHHH		
151	HLLL	152	HHLL	153	LLHH	154	LLHH	155	HHHH		
156	HHHH	157	HLHH	160	HLHH	161	HHHH	162	HHHH		
163	HHHL	164	HHHH	165	HLHH	166	HLLL	167	HLLL		
170	HHHH	171	HHHH	172	HLLL	173	HHLH	174	HLHH		
175	HHHH	176	HLLL	177	HHHH	200	HLLH	201	HLLL		
202	HLHH	203	HLLL	204	HLLL	205	HLHL	206	HLHH		
207	HHHH	210	HHHH	211	HLLL	212	HHHH	213	HLHL		
214	HHHH	215	HLLL	216	HLLL	217	HLHH	220	HLHH		
221	HHHH	222	HLLL	223	HLLL	224	HHHH	225	HHHH		
226	HHHH	227	HHHH	230	HHHH	231	HLHL	232	HLLL		
233	HLHH	234	HLHL	235	HLLL	236	HHHL	237	HHHH		
240	HHHH	241	HHHH	242	HHLH	243	HLLL	244	HHHL		
245	LLLH	246	HHHH	247	HHHH	250	HLLL	251	HLLL		
252	HHHH	253	HLLL	254	LLHH	255	LLLL	256	HLHH		
257	HLHL	260	HHHH	261	HHHH	262	HHHH	263	HLLL		
264	HHHH	265	LLHH	266	HLLL	267	LHHH	270	HHHH		
271	HLLL	272	HLHH	273	HHHH	274	HHHH	275	LLHH		
276	LLHH	277	HLHH	300	HHHL	301	HHHL	302	HHHH		
303	LHHH	304	HHHH	305	HHHL	306	HHHH	307	HLHL		
310	HLLL	311	LHHH	312	HLLL	313	LLHH	314	HLHH		
315	LHLL	316	HHHH	317	LLHH	320	LLHH	321	HLLL		
322	HLLL	323	HLLL	324	HHHH	325	HHHH	326	HLLL		
327	HLLL	330	HHHH	331	HLLL	332	HHHH	333	HHHH		
334	HHHL	335	HLLL	336	HLHH	337	HLHH	340	LHLH		
341	LHHH	342	HHHH	343	HHHL	344	HHHH	345	HLLL		
346	HLHL	347	HLLH	350	HHHL	351	HHHH	352	HLLL		
353	HHHH	354	HLLL	355	HHHH	356	HHHH	357	HLHH		
360	HHHH	361	HHHH	362	HLLL	363	HHHL	364	HHHH		
365	HLLL	366	HHHH	367	LLLH	370	HHHH	371	HHHH		
372	HHHH	373	HHHH	374	HLLL	375	HHHL	376	HLHH		
377	LLHH										

Table 7-5. ROM Bit Lists (Cont'd).
A8U7

									
000	LLLL	001	LLLL	002	LLLL	003	LLLH	004	LLLL
005	LLLL	006	LHHH	007	LLLL	010	LLLL	011	LLHH
012	LLLL	013	LLHH	014	LLLL	015	LHHH	016	LHHH
017	LLLL	020	LLLL	021	LHLH	022	LLLL	023	LLLL
024	LLLL	025	LLLL	026	LLLL	027	LLLL	030	LLHH
031	LHLH	032	LLHH	033	LLLL	034	HLHL	035	LHHH
036	LLHH	037	LLHH	040	HHHH	041	LLHL	042	LLHH
043	LHLL	044	LLLL	045	LLLL	046	LLHH	047	LLLL
050	HLLL	051	LHHH	052	LHHH	053	LLHH	054	LHLH
055	LLHH	056	LLLL	057	LLHH	060	LLLL	061	LLLL
062	LLLL	063	LLHL	064	LLLL	065	LLLL	066	LLHH
067	LLLL	070	LLLL	071	LLLL	072	LHHL	073	LLLL
074	LLLL	075	LHLL	076	HLHH	077	LLLL	100	HLLL
101	LHHH	102	LHHH	103	LLLL	104	LHLH	105	LLLL
106	LLLL	107	LLLL	110	LLHH	111	HHHL	112	LLLL
113	HLLL	114	LLHH	115	LLHH	116	LLHH	117	HHHH
120	LLLL	121	LLHL	122	LLLL	123	LLLL	124	LLLL
125	HHHL	126	LLLL	127	LLHL	130	LLHH	131	LLHH
132	LLLL	133	LHLH	134	LLLL	135	LLHH	136	LLLL
137	LHLL	140	LLLL	141	HHHL	142	LLLL	143	LLLL
144	LLLL	145	LLLL	146	LHHL	147	LLHH	150	LLLL
151	HHHL	152	HLHL	153	LLLL	154	LLLL	155	LLLL
156	LLLL	157	LLLL	160	LLLL	161	LLLL	162	LLLL
163	LLHL	164	LLLL	165	LLLL	166	LLLL	167	HLHH
170	LLLL	171	LLLL	172	HHLH	173	LLHH	174	LLLL
175	LLLL	176	LHHL	177	LLLL	200	LLHH	201	HHHH
202	LLLL	203	LHLH	204	HHLL	205	LLHH	206	LLLL
207	LLLL	210	LLLL	211	LHHH	212	LLLL	213	LHLL
214	LLLL	215	LHHH	216	LHHL	217	LLLL	220	LHLL
221	LLLL	222	HLLH	223	LLHH	224	LLLL	225	LLLL
226	LLLL	227	LLLL	230	LLLL	231	LHLL	232	HHHH
233	LLLL	234	LHHH	235	HHLL	236	LLHH	237	LLLL
240	LLLL	241	LLLL	242	LLHH	243	HHLH	244	LHHH
245	LLLL	246	LLLL	247	LLLL	250	HLLH	251	LHHL
252	LLLL	253	LHHH	254	LLLL	255	LHLH	256	LLLL
257	LLHH	260	LLLL	261	LLLL	262	LHHL	263	LHHH
264	LLLL	265	LLLL	266	LLHH	267	LLLL	270	LLLL
271	LLLL	272	LLLL	273	LLLL	274	LLLL	275	LLLL
276	LLHH	277	LLLL	300	LHHH	301	LLHH	302	LLLL
303	LLLL	304	LLLL	305	LLHH	306	LLLL	307	LLHL
310	LLLL	311	LLLL	312	HLLL	313	LLLL	314	LLLL
315	LLHH	316	LLLL	317	LLLL	320	LLLL	321	HLHL
322	LLLL	323	LHLH	324	LLLL	325	LLLL	326	LLLL
327	HHHH	330	LLLL	331	LLHL	332	LLLL	333	LLLL
334	LHHL	335	HHHL	336	LLLL	337	LLLL	340	LLHH
341	LLLL	342	LLLL	343	LLHL	344	LLLL	345	LHLH
346	LHLH	347	LLHL	350	LHHL	351	LLLL	352	LLLL
353	LLLL	354	LLHL	355	LLLL	356	LLLL	357	LLLL
360	LLLL	361	LLLL	362	LLHL	363	LHLH	364	HLHH
365	LLLL	366	LLLL	367	HLLH	370	LLLL	371	LLLL
372	LLLL	373	LHLL	374	HLHL	375	LHHH	376	LLLL
377	LLLL								

Table 7-5. ROM Bit Lists (Cont'd).
A8U8

									
000	HLLL	001	LLHH	002	LLLH	003	LHLL	004	HLLH
005	LLHL	006	HLHH	007	LHHH	010	LLLL	011	LLHH
012	HLLL	013	LHLH	014	LLLH	015	HHHH	016	LHHH
017	LLHH	020	LHLL	021	LLLH	022	LLHH	023	LLLH
024	LLHH	025	HLLH	026	HLLL	027	LLLL	030	LLLL
031	LLHL	032	HLLL	033	LLHL	034	LHLH	035	LLHH
036	HLLH	037	LLHH	040	HLHL	041	LLLL	042	HLLL
043	LHHL	044	HHHH	045	LLLL	046	LHHL	047	HLLL
050	HLHL	051	HLHL	052	LHHL	053	LLHL	054	HLLL
055	HLHH	056	LLLL	057	LHHH	060	HLHH	061	LLHH
062	HHHH	063	LLHH	064	LLHH	065	LLHH	066	HLLH
067	HLHL	070	HLLH	071	HHLL	072	HHHH	073	LLHL
074	LLHL	075	LLLH	076	LLLH	077	LLLH	100	LLLL
101	LLHL	102	LHHL	103	HLLL	104	LLLL	105	LHLL
106	LHLL	107	LLHL	110	LHLL	111	HLHH	112	HLLH
113	HHHL	114	HLLL	115	LLLL	116	HLHH	117	LHLL
120	HHLH	121	HLLL	122	LHHL	123	LLHH	124	LLLH
125	LHHH	126	LLHH	127	LLHL	130	LLHL	131	HLLL
132	LLLL	133	LHHL	134	HHHH	135	HHLH	136	HHHH
137	HHLH	140	HHLH	141	LHHL	142	LHLH	143	LHHL
144	LHHH	145	LHLH	146	LLLL	147	LLLL	150	HLLL
151	LHHH	152	LHHH	153	HHLL	154	LHHL	155	LHHH
156	HLLL	157	LHLL	160	HHHH	161	HLHH	162	HLLH
163	HLLL	164	LHLH	165	LHHH	166	HHLH	167	LLLL
170	LHHH	171	HLHH	172	HLHL	173	LLLL	174	LHLL
175	LHLH	176	HLHL	177	LLLL	200	HLHL	201	HLLL
202	LLLL	203	HLLL	204	LLHH	205	LLLL	206	HLLL
207	LHHL	210	HHLH	211	LLHL	212	HLLH	213	HLLL
214	LLLL	215	HHHL	216	LLLL	217	LLHH	220	HHLH
221	HLLH	222	HLLH	223	HHHH	224	LHHH	225	LHLL
226	HHLH	227	LLHL	230	HHLL	231	HLLH	232	HLLH
233	HLLL	234	LLHL	235	HHLH	236	LHHL	237	LHHL
240	LHHL	241	LLLH	242	LLLH	243	HLLL	244	HLHH
245	LLLL	246	LHHL	247	LHLH	250	HHHL	251	HHHH
252	LLLL	253	LHLH	254	HHHL	255	LLHL	256	LLHL
257	LLHH	260	LHLH	261	LLLH	262	LHHL	263	LHLH
264	HLLL	265	LHHL	266	LHLL	267	LHHH	270	HHLL
271	LLLH	272	LLHH	273	HLLH	274	HLLH	275	LLLH
276	HLHH	277	LLHH	300	LHHH	301	LHLL	302	LHHH
303	HHHH	304	HLHH	305	HLLL	306	LHLL	307	LLHL
310	HHHL	311	HLLL	312	LLHL	313	HHLH	314	LLHH
315	HLLL	316	HLLH	317	LLHL	320	HLHL	321	LHHL
322	LHLL	323	HHHH	324	HHLH	325	LLHH	326	LLLH
327	HHHH	330	LLHL	331	HHLH	332	LHHH	333	LLHL
334	HLLL	335	LHHH	336	HLLL	337	LLHH	340	LLLL
341	HHLL	342	LLLL	343	LLHL	344	HHHH	345	LHHH
346	HHLH	347	LLHL	350	HLHH	351	HHHL	352	LHLH
353	HHHH	354	LLLL	355	LHLL	356	HLLL	357	LLHH
360	LHHL	361	HHLH	362	LHLH	363	LLLH	364	HHHH
365	HHHL	366	HLHL	367	LHLL	370	HHHL	371	HHHH
372	LHHL	373	HHLH	374	HLLL	375	LLLL	376	LHHH
377	LHHH								

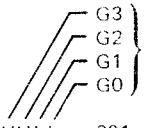
Table 7-5. ROM Bit Lists (Cont'd).
A8U9

									
000	HLLL	001	LLHL	002	LHLH	003	HHHL	004	HLLH
005	HLHL	006	HLLL	007	LLLL	010	LLLL	011	LHHL
012	HLLL	013	LHHH	014	LLLH	015	HHHH	016	HLLL
017	LLHH	020	HLLL	021	LLHH	022	LHHH	023	HLLL
024	HLHH	025	LLHH	026	HLLL	027	LLLL	030	LLHL
031	HLLL	032	HLLH	033	LLHL	034	HLLL	035	LLHH
036	HHLL	037	LLHH	040	LLHL	041	HLLL	042	HLHL
043	HLHL	044	HHHH	045	HLHL	046	LHHH	047	HLLL
050	LLHL	051	LLHL	052	LHHL	053	LLHL	054	LHHH
055	LLHH	056	LLLL	057	HHHH	060	LLHH	061	LLHH
062	LLHL	063	LLLH	064	LLHH	065	LLHH	066	HLLH
067	HLLL	070	HLLH	071	HHLL	072	HLLL	073	LLHL
074	HHLL	075	LLLL	076	LLLH	077	LLLL	100	LLLL
101	HLHH	102	LHHH	103	HLLL	104	LLLL	105	LHLL
106	LHLL	107	LLHL	110	LHLL	111	HLHH	112	HLLL
113	HHHL	114	HLLL	115	LHLL	116	HLHH	117	LHLL
120	LLLL	121	HLLL	122	LHHH	123	LLHH	124	LLHH
125	LLLL	126	LLHH	127	LLHL	130	LLHL	131	LLLL
132	LLLL	133	LLHH	134	LHLL	135	HLHL	136	HHHH
137	HHLH	140	HHLH	141	LHHH	142	HLLH	143	HHHL
144	LHLL	145	LHLL	146	LLLL	147	LLLL	150	HLHH
151	LHHH	152	LLHH	153	LHHH	154	LHHL	155	LHHH
156	LHHL	157	LLHH	160	HLHH	161	HHHL	162	LHHH
163	HHLL	164	HHHH	165	LHHL	166	LLHH	167	LLLL
170	HLLL	171	HLHH	172	HLHL	173	LLLL	174	HHHH
175	LHLH	176	LLLH	177	LLLL	200	HLHL	201	HLHL
202	HLLL	203	LHHH	204	LLLL	205	LLLL	206	HLLH
207	LHHL	210	HHLH	211	LLHL	212	HLLH	213	LHLL
214	LLLL	215	LHHL	216	LLLL	217	LLLH	220	HHHH
221	LLLH	222	HLLH	223	HHHH	224	LHHH	225	HLHH
226	HHLL	227	LHLH	230	HHLL	231	HLLH	232	HLLH
233	HHHH	234	LLHL	235	LHLH	236	LHHL	237	LHHL
240	HLHL	241	LLLL	242	LLLH	243	HLLL	244	HLHH
245	LLLL	246	LHHL	247	LLHL	250	HLHL	251	HLLL
252	LLLL	253	LHHH	254	HHHL	255	LLHL	256	LLHL
257	LLHH	260	HHLL	261	HHLH	262	LHLL	263	LHLH
264	LHHL	265	HHLL	266	LHLL	267	LHHH	270	HLLH
271	LLLH	272	HHHL	273	HLHL	274	LHHL	275	LLLL
276	HLHH	277	LLHH	300	LLHL	301	HHLH	302	LHHH
303	HHHH	304	HLHH	305	HLLL	306	LHLL	307	LLHL
310	LHLL	311	HLLH	312	HLHL	313	HHLH	314	LLHH
315	HHLH	316	HLLH	317	LHHH	320	LHHL	321	HHHL
322	HHLL	323	HHHL	324	HLLL	325	HLLH	326	LHLL
327	HLLH	330	LLHL	331	HLLL	332	LHHH	333	HHLH
334	HHLL	335	LLHL	336	HHLL	337	LLHH	340	LHHL
341	HHLL	342	HHHH	343	HLLL	344	HLLL	345	HLLL
346	HLHL	347	LLLL	350	HLHH	351	HLLL	352	LHLH
353	HHHH	354	LLHH	355	HHLL	356	HLLL	357	LLHH
360	HHHL	361	HLLH	362	LLHH	363	HHHL	364	LLLL
365	LHLL	366	LHHL	367	LHLL	370	HHHL	371	HLLL
372	LHHL	373	HHLH	374	HLLL	375	LHLH	376	LHHL
377	LHHH								

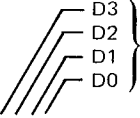
Table 7-5. ROM Bit Lists (Cont'd).
A8U10

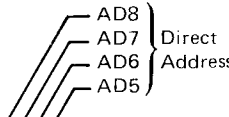

				ATR A Reg to R Bus Used for Flag Set And Clear And For Transfer Instructions					
000	HLLL	001	HHHH	002	HHHH	003	HLLH	004	HHHH
005	HHHH	006	HLHH	007	HHLL	010	HHHH	011	HHLL
012	HHHH	013	HHLL	014	HHHH	015	LHHH	016	HLLL
017	HHHH	020	HLLH	021	HHHH	022	HHLL	023	HHHH
024	HHHH	025	HHHH	026	HHHH	027	HHHH	030	HHHH
031	HHHH	032	HHLL	033	HLHH	034	HHLH	035	HLHH
036	HHLH	037	HHHH	040	HHHH	041	HHHH	042	HHHH
043	HHLL	044	LHHH	045	HHHH	046	HHHH	047	HHHH
050	HHHH	051	HHHH	052	HLHL	053	HHHH	054	HHHH
055	HHHH	056	HHHH	057	HHLH	060	LHHH	061	HLHL
062	LHHH	063	HHHH	064	HHHH	065	HLLH	066	HHHH
067	HLHH	070	HLHL	071	HHHH	072	HLHH	073	HLHH
074	HLLH	075	HHHH	076	HHHH	077	HHLL	100	HHHH
101	HLLL	102	HHHH	103	HHHH	104	HHLH	105	LHHH
106	LHHH	107	HLLH	110	HHHH	111	LLHL	112	HHHH
113	HHLL	114	HLHH	115	HHHH	116	HHLH	117	HHHH
120	HLLL	121	HHHH	122	LHHH	123	HHHH	124	HHHH
125	HHHH	126	HHLL	127	HLHH	130	HHHH	131	HLHL
132	HHHH	133	HHLL	134	LHHH	135	HHHH	136	LHHL
137	HHHH	140	HLLH	141	HLLH	142	HHHH	143	HHHH
144	HHHH	145	HHHH	146	HLHL	147	HHHH	150	LHHH
151	HHHH	152	HLHL	153	HLHL	154	HHHH	155	HHHH
156	LHHH	157	HHHH	160	HLLH	161	LLLL	162	HHHH
163	HHHH	164	HHHH	165	HLHL	166	HHHH	167	HHHH
170	HHHH	171	HLHH	172	LHHH	173	HHHH	174	HHHH
175	HHHH	176	HHLH	177	HHHH	200	HLHH	201	HHHH
202	HHHH	203	HLLL	204	HHHH	205	HHLL	206	HHHH
207	HLHL	210	HLHL	211	HHLL	212	LHHH	213	HHLL
214	HLLH	215	HHHH	216	HHHH	217	HHHH	220	HHLH
221	HHHH	222	HHHH	223	HHHH	224	HHHH	225	HHHH
226	LLLL	227	HHHH	230	HHHH	231	HHLL	232	HLLH
233	HHHH	234	LHHH	235	LHHH	236	LHHH	237	HHHH
240	HHHH	241	HHHH	242	HLHH	243	HLHH	244	HHLL
245	HHHH	246	HHHH	247	HHHH	250	HHHH	251	HLHH
252	LHHH	253	HHHH	254	HHHH	255	HLHH	256	HHHH
257	HHHH	260	LHHH	261	LHHH	262	HHLH	263	HHHH
264	HHHH	265	HHHH	266	HLHL	267	HLLH	270	HHHH
271	LLHL	272	LHHH	273	HHHH	274	HHHH	275	HHHH
276	HHLH	277	HHHH	300	HHHH	301	HHLL	302	LHHH
303	HHHH	304	HLLH	305	HHHH	306	HHHH	307	HLHH
310	HLLH	311	HLLL	312	HHHH	313	HHHH	314	HHHH
315	HHHH	316	HHHH	317	HLHL	320	HHHH	321	HLLH
322	HHHH	323	HHHH	324	HHHH	325	HHLL	326	HLLL
327	HHHH	330	HLLH	331	HHHH	332	LHHH	333	LHHH
334	HLLL	335	HHHH	336	LHHH	337	HHHH	340	LHHH
341	HLLH	342	HHHH	343	HHHH	344	LLLL	345	HHHH
346	HHHH	347	HHHH	350	HLHL	351	LHHH	352	HHHH
353	HHHH	354	HHHH	355	HHHH	356	HLHL	357	HLHL
360	HLLL	361	HLLL	362	HLHL	363	HHLL	364	HHLH
365	HLLH	366	HHHH	367	HHLH	370	HHHH	371	LHHH
372	HLLL	373	HHLH	374	HLHH	375	HHHL	376	HLLH
377	HHHH								

Table 7-5. ROM Bit Lists (Cont'd).
A8U11

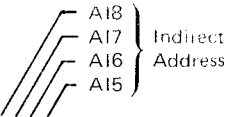
									
000	HHHH	001	HHHH	002	HHLL	003	LLLL	004	HHLL
005	HHLL	006	HHLL	007	HHLL	010	HHHH	011	LLLL
012	HHHH	013	LLLL	014	HHLL	015	HHLL	016	HHHH
017	HHHH	020	HHHH	021	HHHH	022	HHHH	023	HHHH
024	HHHH	025	HHLL	026	HHHH	027	LLLL	030	LLLL
031	HHLL	032	HHLL	033	HHLL	034	HHLL	035	HHLL
036	HHHH	037	HHHH	040	HHHH	041	HHHH	042	HHHH
043	LLLL	044	HHLL	045	LLLL	046	HHHH	047	LHLL
050	HHHH	051	HHHH	052	HHHH	053	HHHH	054	HHHH
055	HHHH	056	HHLH	057	LHLL	060	HHLL	061	LLLL
062	HHLL	063	HHHH	064	HHHH	065	LLLL	066	HHHH
067	HHLL	070	LLLL	071	HHHH	072	HHLL	073	HHLL
074	LLLL	075	HHHH	076	HHHH	077	HLLH	100	HHHH
101	HHHH	102	HHHH	103	HLLH	104	LHLL	105	LHLL
106	LHLL	107	HHLL	110	HHHH	111	HHHH	112	HHHH
113	HHHH	114	HHHH	115	HHHL	116	LHLL	117	LLLL
120	LHLL	121	LHHH	122	HHHH	123	HHHH	124	HHHH
125	HHHH	126	HHHH	127	HHLL	130	LLLL	131	HHHH
132	LLLL	133	HHHH	134	LHHH	135	HHHH	136	HHLL
137	HHHH	140	LLLL	141	LLLH	142	LHHH	143	HHHH
144	HHLL	145	HHHH	146	HHHH	147	HHHH	150	HHLL
151	HHHH	152	HHHH	153	HHHH	154	LLLL	155	HHHH
156	HHLL	157	HHHH	160	HHHH	161	LLLL	162	LHLL
163	HHHH	164	HHHH	165	HHHH	166	HHHH	167	HHHH
170	HHHH	171	HHLL	172	HHLL	173	LLLL	174	HHHH
175	LHLL	176	HHHH	177	HHHH	200	LHLL	201	HHHH
202	HHHH	203	HHHH	204	HHHH	205	HHLL	206	HHHH
207	HHHH	210	HHHH	211	HLLL	212	HHLL	213	HLLL
214	LLLL	215	HHHH	216	HHHH	217	HHHH	220	HHHH
221	HHHH	222	HHHH	223	HHHH	224	HHHH	225	HLLL
226	LLLL	227	HHHH	230	HHLL	231	LLLL	232	LLLL
233	HHHL	234	HHHL	235	LHHH	236	LLLL	237	LHLL
240	LLLL	241	HHHH	242	HHHL	243	HHHH	244	HLLL
245	HHHH	246	HHLL	247	HHHH	250	HHHH	251	HHLL
252	LLLL	253	HHHH	254	LLLL	255	LHLL	256	HHHH
257	HHHH	260	HHLL	261	LLLL	262	LHLL	263	HHHH
264	HHHH	265	HHLL	266	HHHH	267	LLLL	270	HHLL
271	HHHH	272	LLLL	273	HHHH	274	HHHH	275	HHLL
276	HHLL	277	HHHH	300	HHHH	301	HLLL	302	HHLH
303	HHHH	304	LLLH	305	HHHH	306	HHLL	307	HHLL
310	LLLL	311	LLLL	312	HHHH	313	HHLL	314	HHHH
315	HHHH	316	LLLL	317	HHHH	320	HHLL	321	LLLL
322	HHHH	323	HHHH	324	HHHH	325	HLLH	326	HHHH
327	HHHH	330	LLLL	331	HHHH	332	LLLL	333	HHLL
334	HHHH	335	HHHH	336	LLLH	337	HHHH	340	LLLL
341	HHHH	342	LHLL	343	HHHH	344	HHLH	345	HHHH
346	HHHH	347	LLLL	350	HHHH	351	HHLL	352	HHHH
353	HHHH	354	HHHH	355	HHLL	356	HHHH	357	HHHH
360	HHHH	361	HHHH	362	HHHH	363	LLLL	364	LHLL
365	LLLL	366	HHHH	367	HHHH	370	LLLL	371	HHLL
372	HHHH	373	LHLL	374	HHLL	375	HHHL	376	LLLL
377	HHLL								

**Table 7-5. ROM Bit Lists (Cont'd).
A8U18**

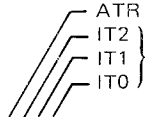
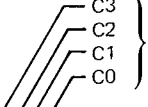
						Also Used To Set And Clear FLA And FLB, And To Generate Transfer Instructions			
000	LLLL	001	LLLL	002	LLLL	003	LLLL	004	LLHL
005	LLLL	006	LLHL	007	LLLL	010	LLLL	011	LHHL
012	LLLL	013	LLLL	014	LHLL	015	LLLL	016	LLLH
017	HLHL	020	HHLL	021	LHLL	022	LLLL	023	HLLL
024	LLLL	025	LHLL	026	LHLH	027	LLLL	030	LLLL
031	LHLL	032	LLLL	033	LHLL	034	LLLL	035	LLLL
036	LLLL	037	LLHH	040	LLLL	041	LLLL	042	HLLL
043	LLLL	044	LLLL	045	LLLL	046	LHHL	047	LLLL
050	LLLL	051	LLLL	052	LLLL	053	LLLL	054	HLLH
055	LLLL	056	LLLL	057	LLLL	060	LLLL	061	LLLL
062	LLLL	063	HLLL	064	HHLH	065	LHHL	066	LLLL
067	LLHH	070	LLHH	071	LLLL	072	LLHH	073	LHLL
074	HHHL	075	LLLL	076	LLLL	077	LLLL	100	LLLL
101	LHLH	102	LLLL	103	LLLL	104	LLLL	105	LLLL
106	LLLL	107	LLLL	110	LLLL	111	LLLL	112	HLLL
113	LLLL	114	LHHL	115	LLLL	116	LLLL	117	LLHL
120	LHLL	121	LLHL	122	LLLL	123	LLHL	124	LLLL
125	LHLH	126	LLLL	127	LHLH	130	LLLL	131	HLLL
132	LLLL	133	LLLL	134	LLLL	135	LLLL	136	LLLL
137	LLLL	140	LLLL	141	LLLL	142	LLLL	143	LLLL
144	LLHL	145	LHLL	146	LLLL	147	LLLL	150	LLLL
151	LHLL	152	LLLL	153	HLLL	154	HLLL	155	LLLL
156	LLLL	157	LHHL	160	LLLL	161	LLLL	162	LLLL
163	LLLL	164	LLLL	165	HLHH	166	LLHL	167	LLLL
170	LLLL	171	LLLL	172	HLHH	173	LLLL	174	LHHL
175	LLLL	176	LLLL	177	LLLL	200	HHHH	201	LLLL
202	LHHL	203	LHLH	204	HLHL	205	LHHL	206	HLHL
207	LLLL	210	LLLL	211	LLLL	212	LLLL	213	HHHL
214	LLLL	215	LLLL	216	LLLL	217	LLHH	220	LHHL
221	LLLL	222	HHLL	223	LLLL	224	LLLL	225	LLLL
226	LLLL	227	LLLL	230	LLLL	231	LHHH	232	LLLL
233	LHHL	234	HLLH	235	LLLL	236	LLLL	237	LLLL
240	LLLL	241	LLLL	242	LLLL	243	HLLL	244	LLLL
245	HLLL	246	LLLL	247	LLLL	250	LLLL	251	LLLH
252	LLLL	253	LLLL	254	LHLL	255	LLHL	256	HHHL
257	LLHH	260	LLLL	261	LLLL	262	LLLL	263	LLLL
264	LLLL	265	LLHL	266	LHHH	267	LHLL	270	LLLL
271	LLLL	272	LHHL	273	LLLL	274	LLLL	275	LLHL
276	LHLL	277	LLLL	300	LLLL	301	LLLL	302	LLLL
303	LLHL	304	LLLL	305	LLLL	306	LLLL	307	LHLH
310	HHHH	311	LHLL	312	LLLL	313	LLHL	314	LHLH
315	LHLH	316	LLLL	317	HLLL	320	LLHL	321	LLLL
322	HLHH	323	HHHH	324	LLLL	325	LLLL	326	LLHL
327	LLLH	330	LLLL	331	LLLL	332	LLLL	333	LLLL
334	LLHL	335	LHLL	336	HHLL	337	LLLH	340	LLHL
341	HLLL	342	LLLL	343	LLLL	344	LLLL	345	LLLL
346	LHLL	347	LLHH	350	LLLL	351	LLLL	352	LLLL
353	LLLL	354	LLLL	355	LLLL	356	LLLL	357	LHHL
360	LLHL	361	LLLL	362	LLLL	363	LLLL	364	LLLL
365	HHHL	366	LLLL	367	LHLL	370	LLLL	371	LLLL
372	HLLL	373	LLLL	374	LLLL	375	LLLL	376	LLHH
377	LLHL								

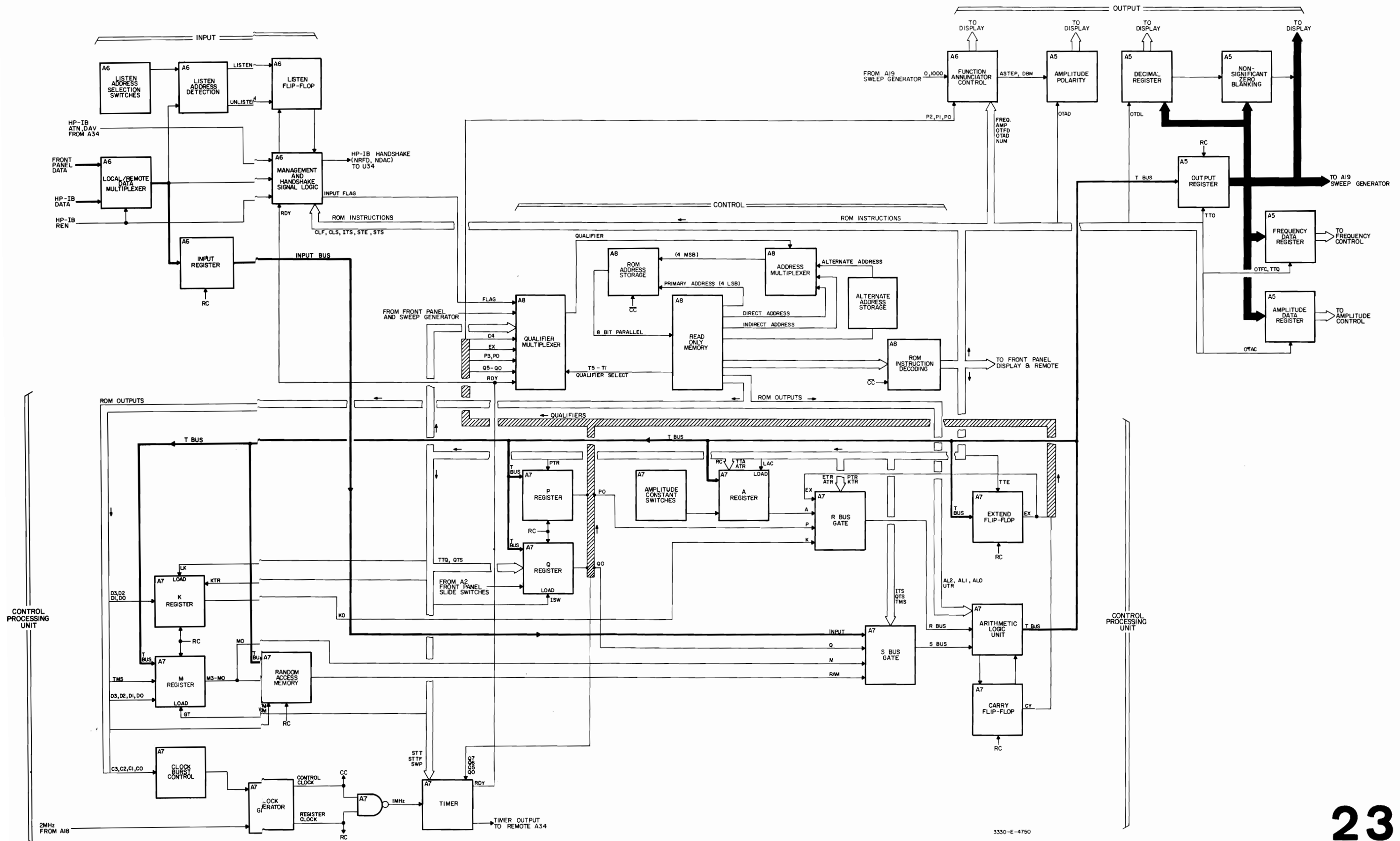

3330-E-4750

Figure 7-29. Controller Block Diagram.
7-93

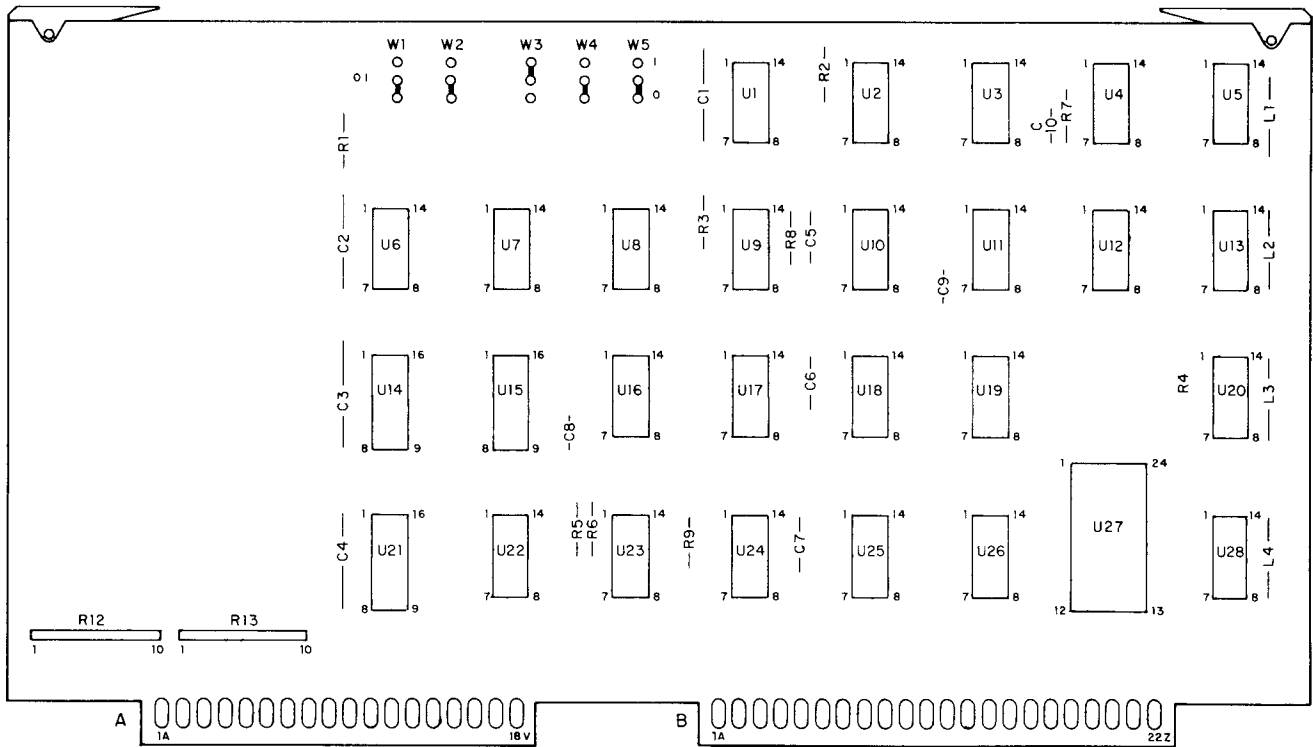

3330-B-4764

A6A
03330-66573
03330-66578

A6B
03330-66506
03330-66576

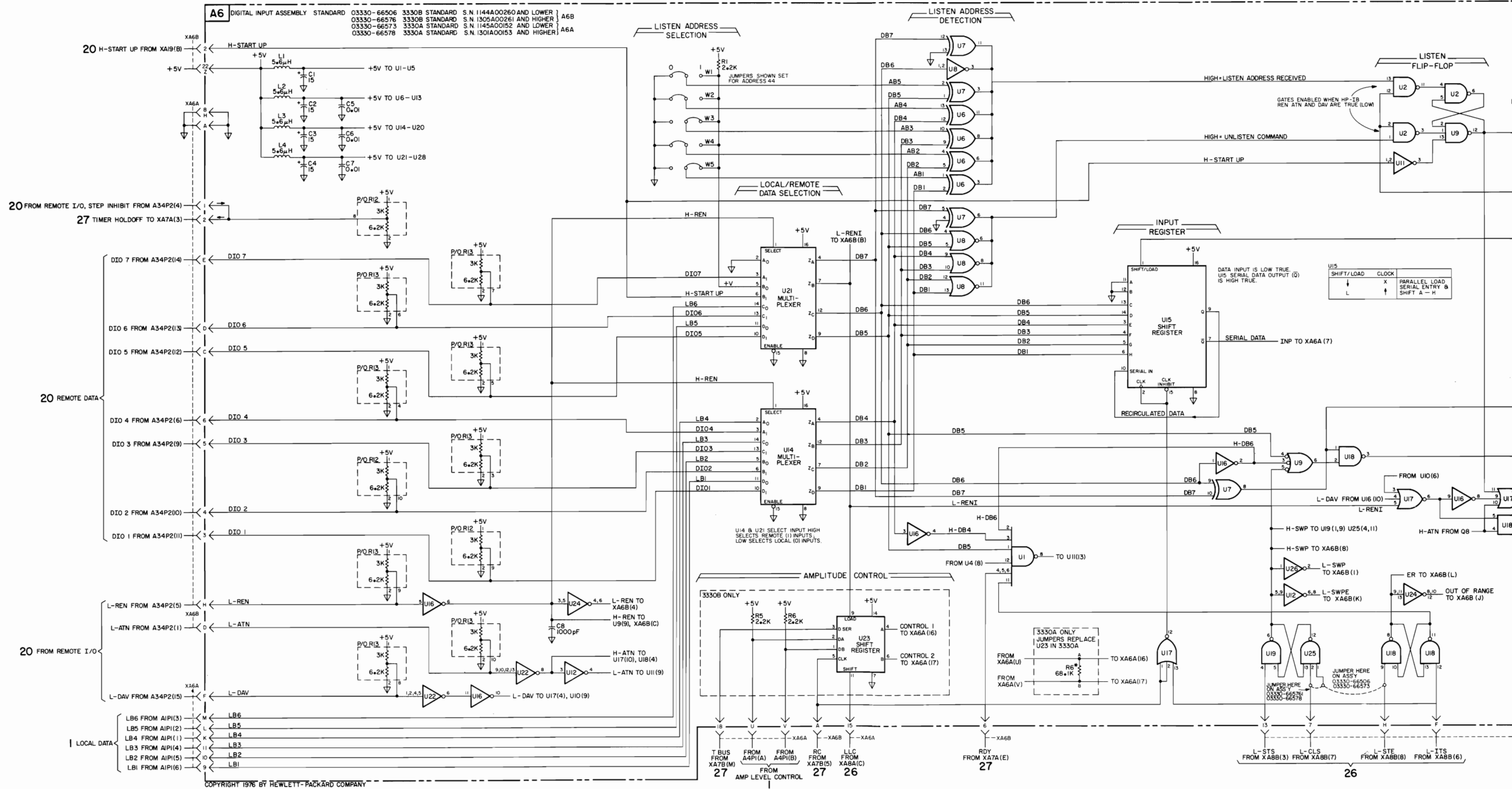

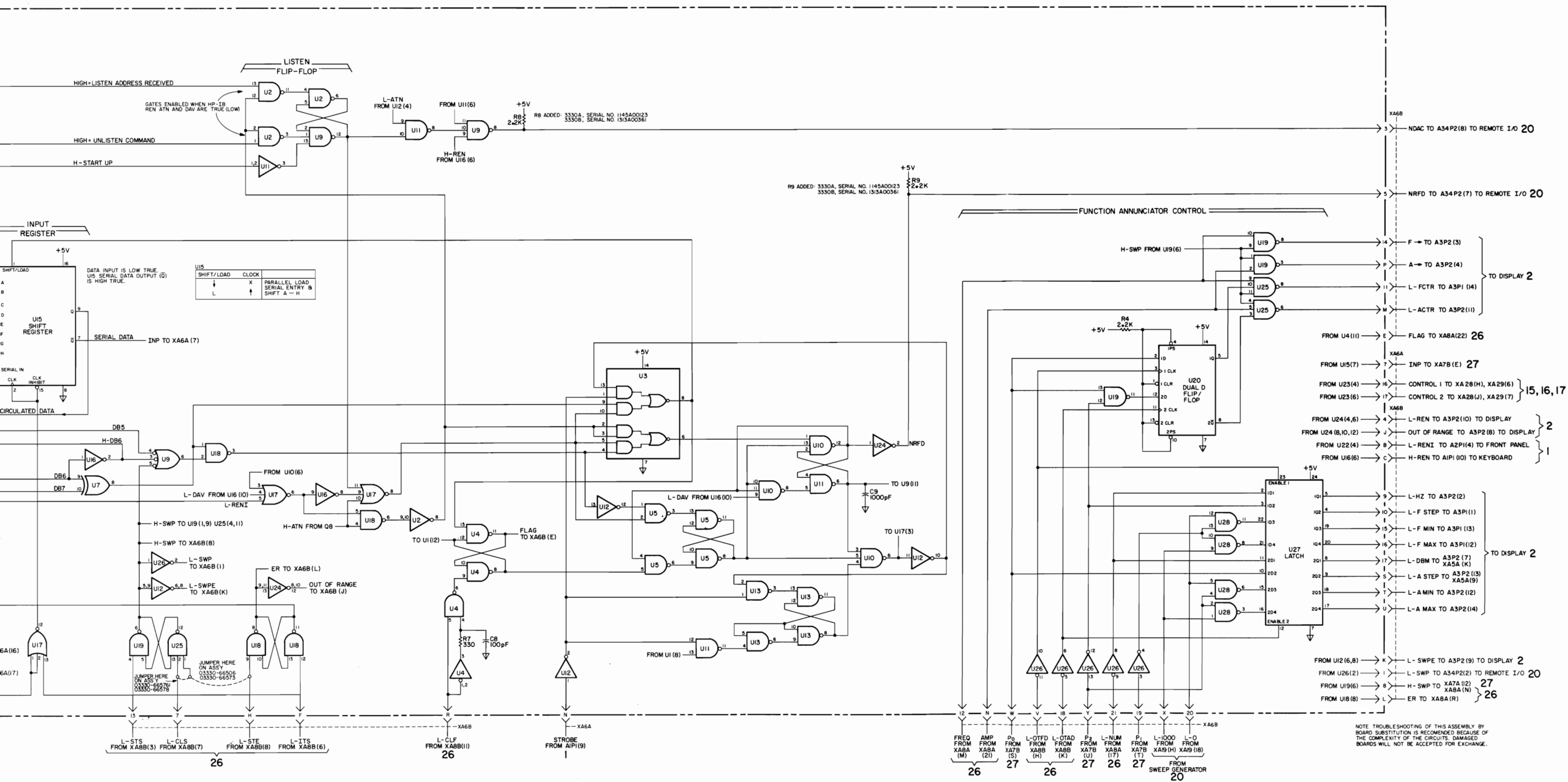
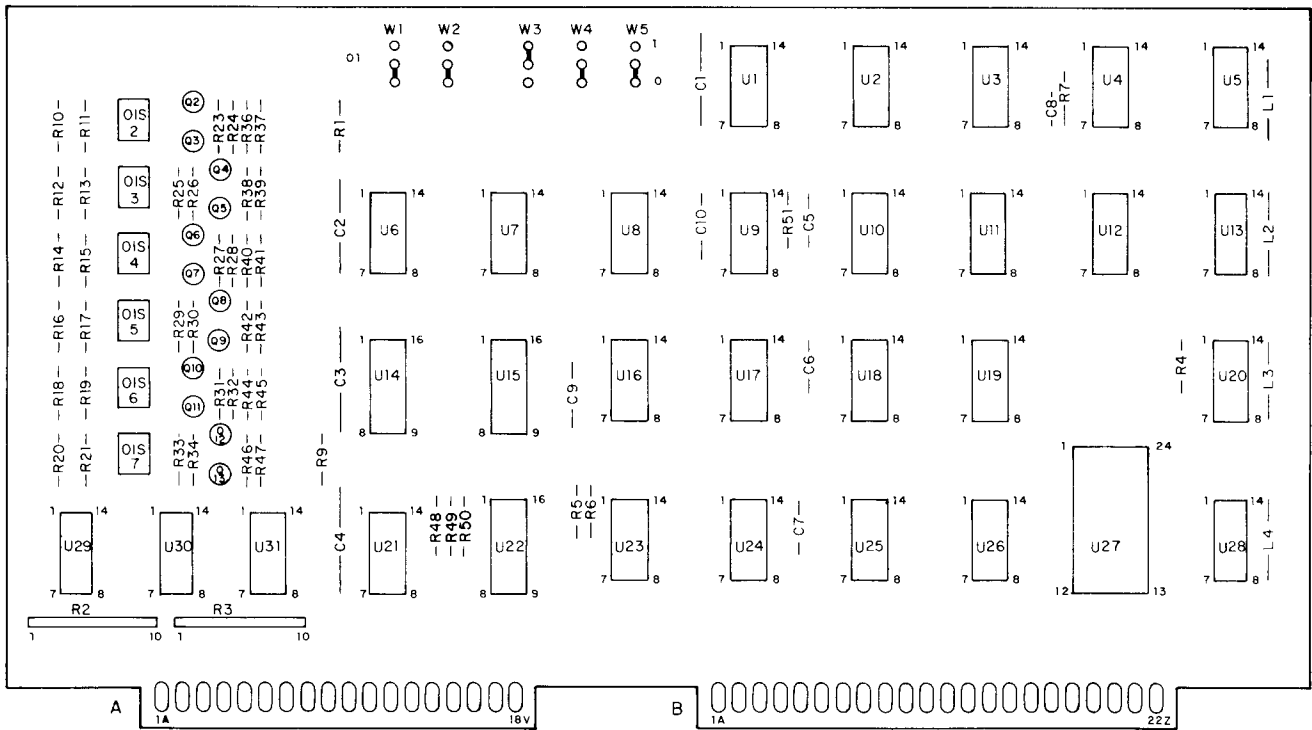

Figure 7-30. Logic Input Assembly, A6 Standard.



3330-B-4763

A6A
03330-66574
03330-66579

A6B
03330-66563
03330-66577

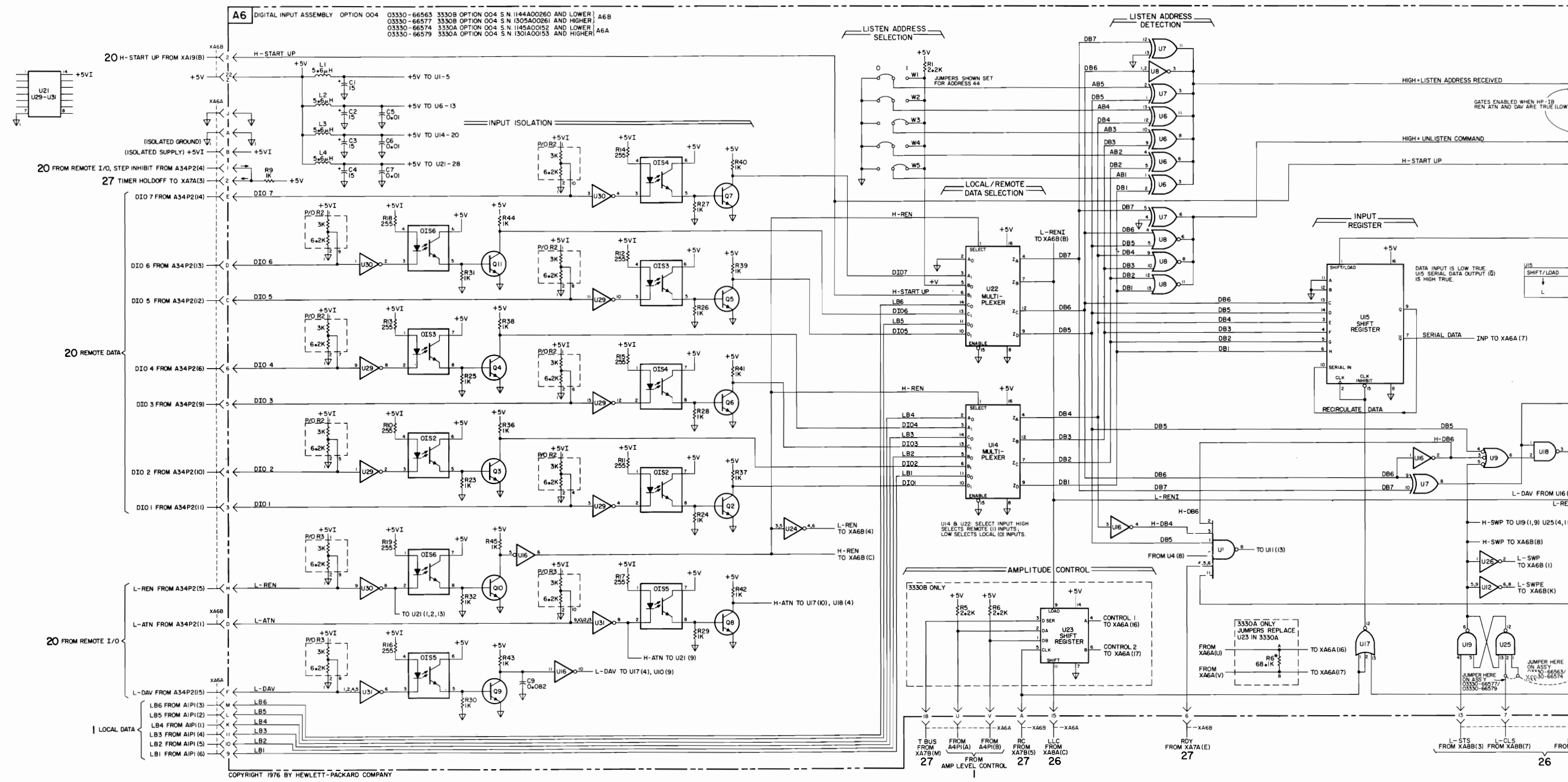

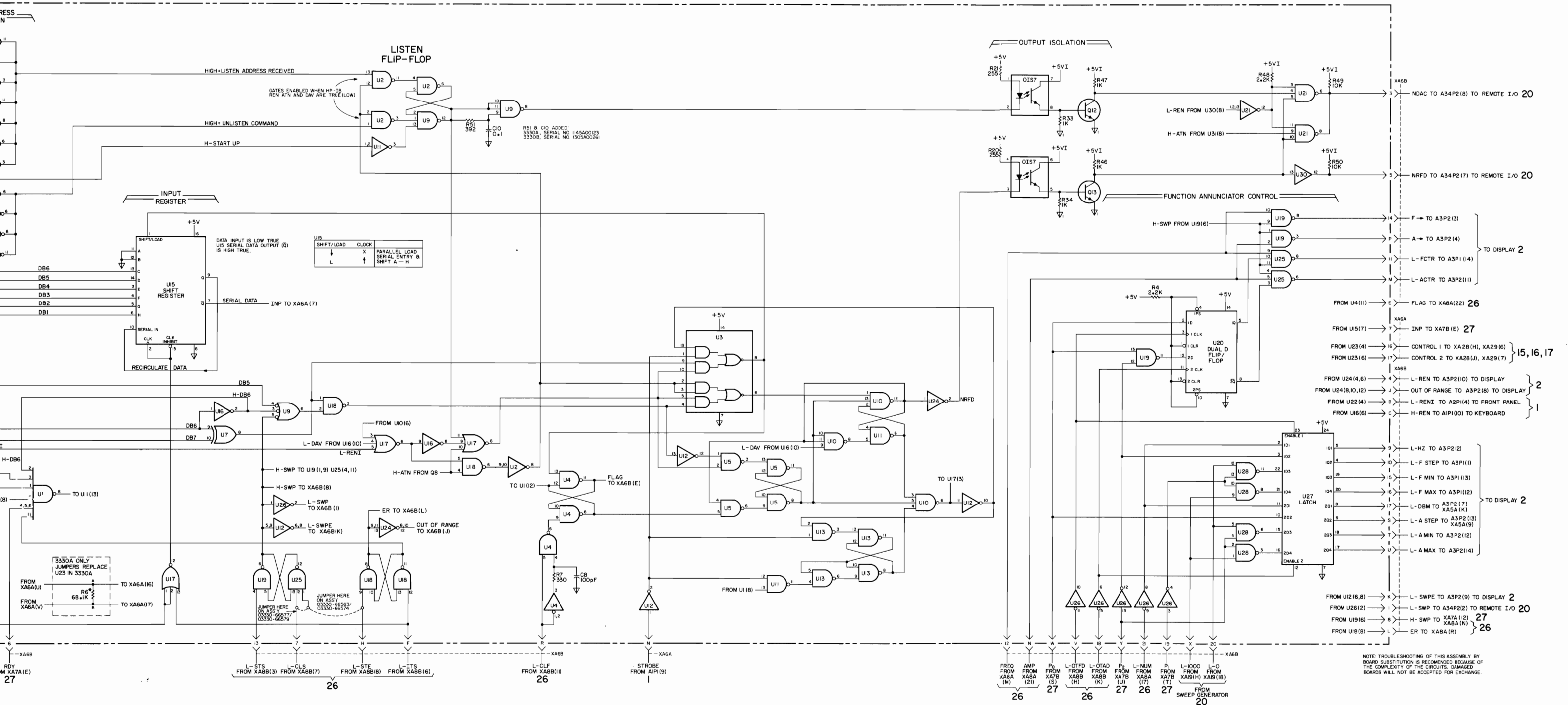
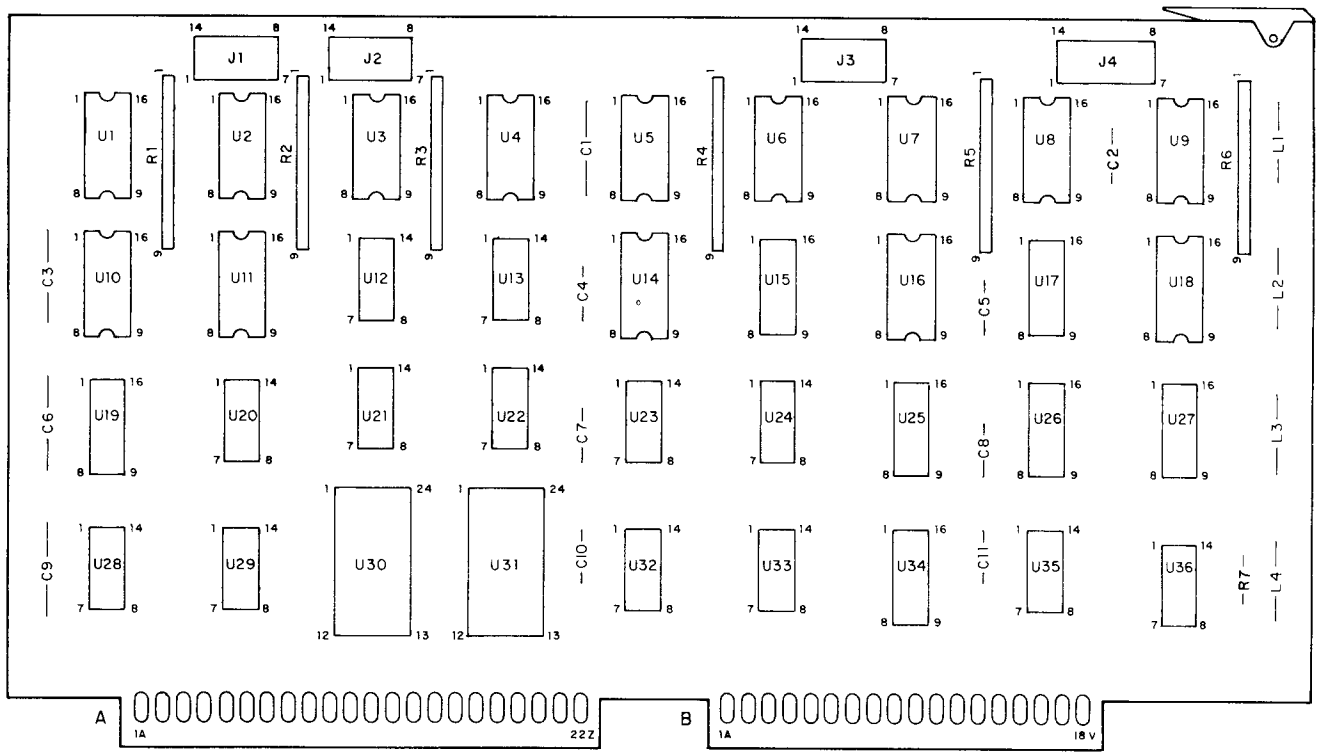

Figure 7-31. Logic Input Assembly, A6 Option 004.
7-97



3330-B-4762

A8
 03330-66508
 03330-66575

A8 CONTROL ASSEMBLY
 03330-66508 3330A S.N. 1145A00152 & LOWER A8A
 03330-66508 3330B S.N. 1144A00260 & LOWER A8B
 03330-66575 3330A S.N. 1301A00153 & HIGHER A8A
 03330-66575 3330B S.N. 1305A00261 & HIGHER A8B

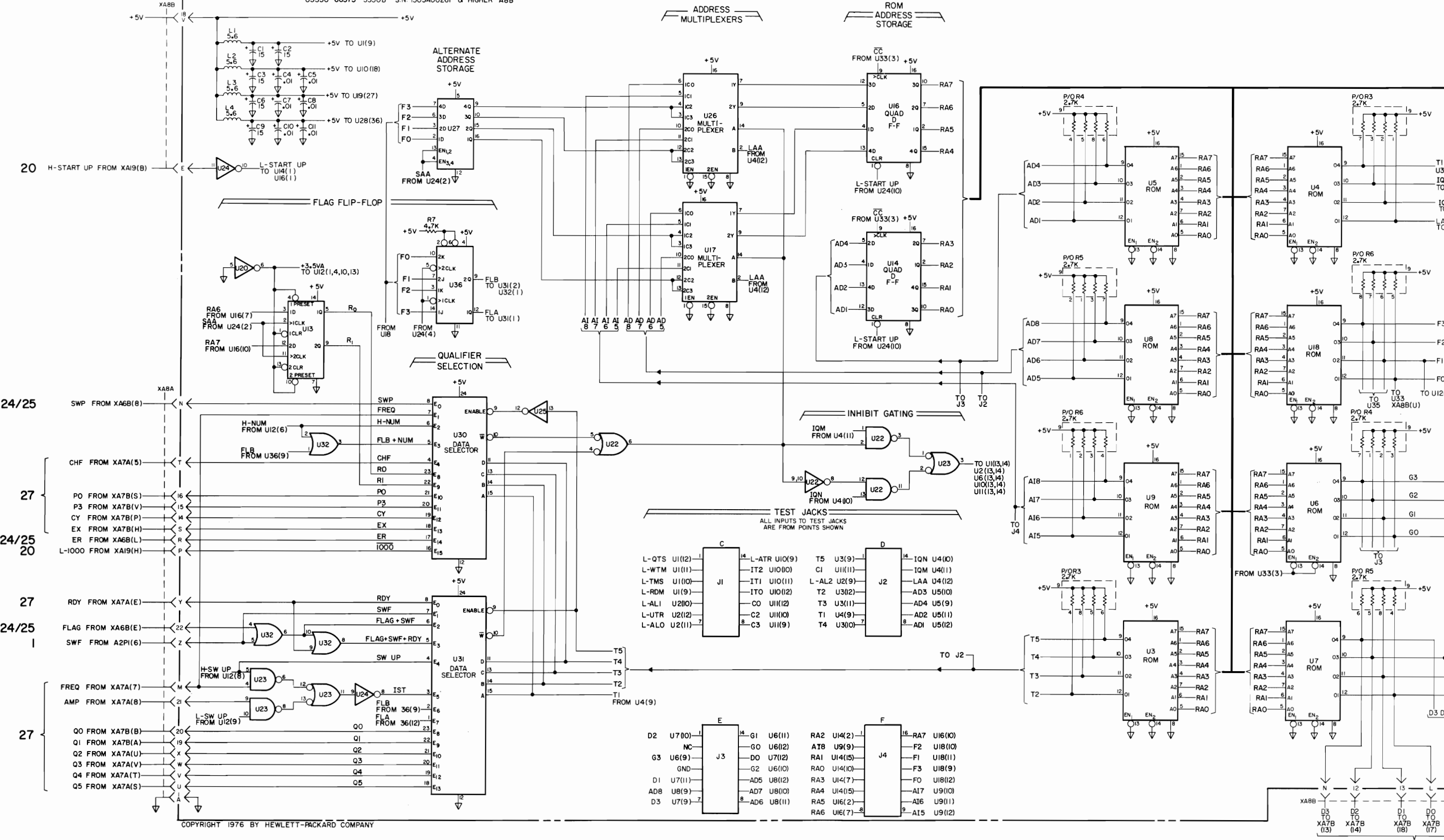

- 20 H-START UP FROM XA19(B)
- 24/25 SWP FROM XA6B(8)
- 27 CHF FROM XA7A(5)
- 24/25 PO FROM XA7B(S)
- 27 P3 FROM XA7B(V)
- 24/25 CY FROM XA7B(P)
- 20 EX FROM XA7B(H)
- 27 ER FROM XA6B(L)
- 20 L-1000 FROM XA19(H)
- 27 RDY FROM XA7A(E)
- 24/25 FLAG FROM XA6B(E)
- 1 SWF FROM A2PI(6)
- FREQ FROM XA7A(7)
- AMP FROM XA7A(8)
- 27 Q0 FROM XA7B(B)
- Q1 FROM XA7B(A)
- Q2 FROM XA7A(U)
- Q3 FROM XA7A(V)
- Q4 FROM XA7A(T)
- Q5 FROM XA7A(S)

- TEST JACKS**
 ALL INPUTS TO TEST JACKS ARE FROM POINTS SHOWN
- | | | | | |
|----------|--------------|--------------|-------------|-------------|
| C | L-QTS U1(12) | L-ATR U10(9) | T5 U3(9) | IQN U4(10) |
| D | L-WTM U1(11) | IT2 U10(10) | C1 U11(11) | IQM U4(11) |
| | L-TMS U1(10) | ITI U10(11) | L-AL2 U2(9) | LAA U4(12) |
| | L-RDM U1(9) | ITO U10(12) | T2 U3(10) | AD3 U5(10) |
| | L-ALI U2(10) | CO U11(12) | T3 U3(11) | AD4 U5(9) |
| | L-UTR U2(12) | C2 U11(10) | T1 U4(9) | AD2 U5(11) |
| | L-ALO U2(11) | C3 U11(9) | T4 U3(10) | ADI U5(12) |
| E | D2 U7(10) | G1 U6(11) | RA2 U14(2) | RA7 U16(10) |
| | G3 U6(9) | GO U6(12) | A18 U9(9) | F2 U18(10) |
| | D1 U7(11) | G2 U6(10) | RA1 U14(15) | F1 U18(11) |
| | AD8 U8(9) | AD5 U8(12) | RA0 U14(10) | F3 U18(9) |
| | D3 U7(9) | AD7 U8(10) | RA3 U14(7) | FO U18(12) |
| | | AD6 U8(11) | RA4 U14(15) | A17 U9(10) |
| | | | RA5 U16(2) | A16 U9(11) |
| | | | RA6 U16(7) | A15 U9(12) |

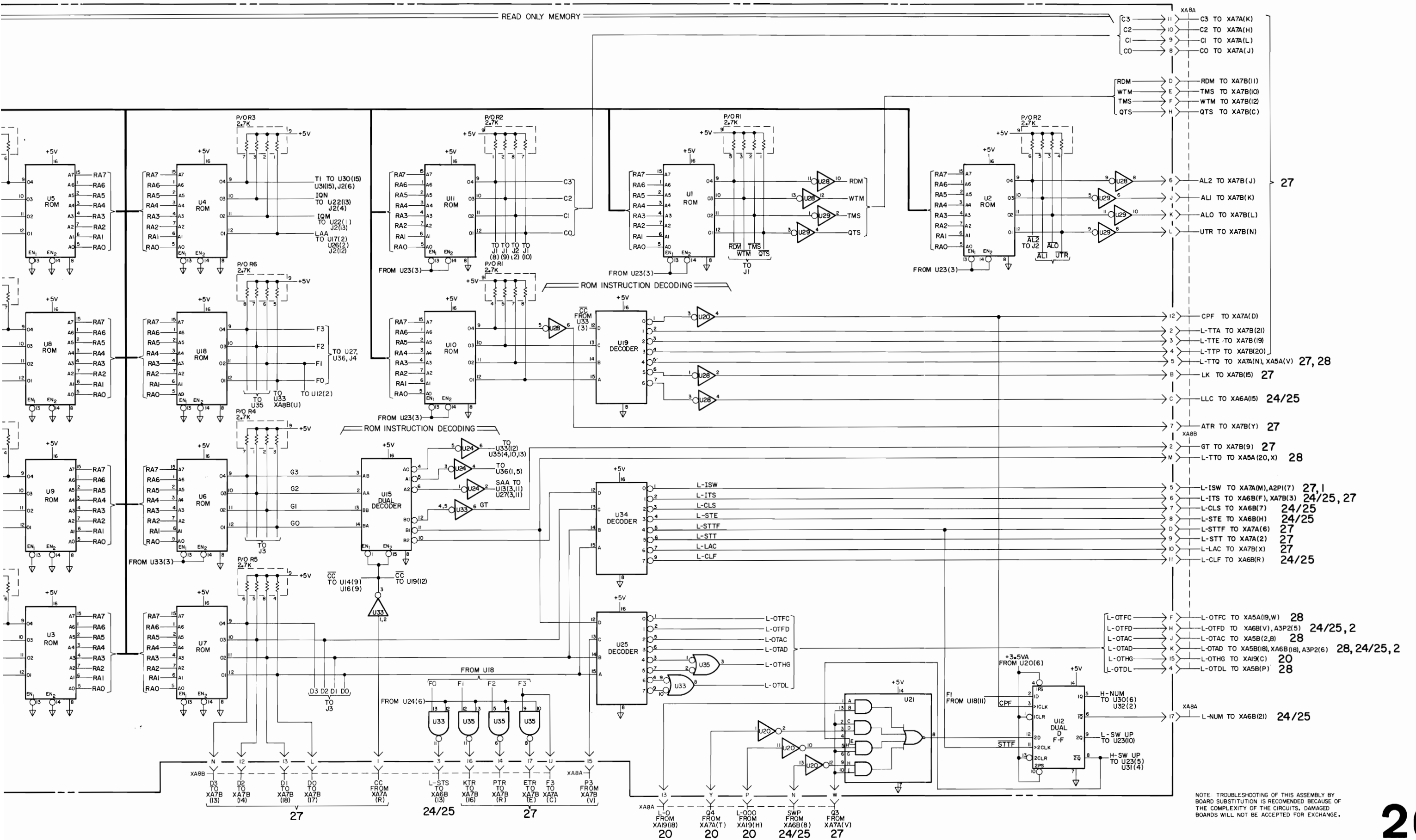

NOTE: TROUBLESHOOTING OF THIS ASSEMBLY BY BOARD SUBSTITUTION IS RECOMMENDED BECAUSE OF THE COMPLEXITY OF THE CIRCUITS. DAMAGED BOARDS WILL NOT BE ACCEPTED FOR EXCHANGE.

Figure 7-32. Control Assembly, A8.

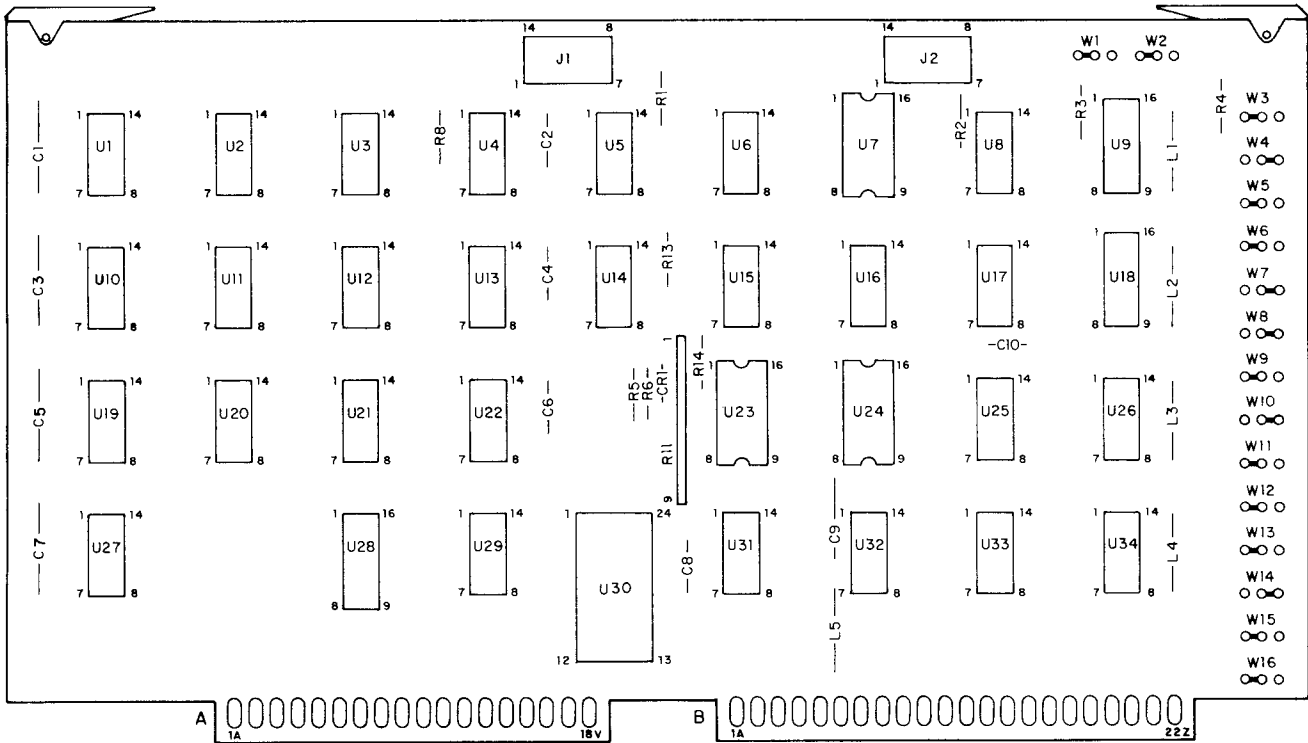

A7
03330-66507

3330-B-4765

26 { C
C
C
L-STT
L-ST
18 2W
24, 25 SW
26 L-IS
26 L-TI
26 QT
SV
SV
SV
SV
SV
SV
SV
SV

Instrument Model	Maximum Output	Jumper Wire Positions															
		W1	W2	W3	W4	W5	W6	W7	W8	W9	W10	W11	W12	W13	W14	W15	W16
Standard	+ 13.44 dBm 50 Ω	0	0	0	1	0	0	1	1	0	1	0	0	0	1	0	0
Option 001	+ 11.68 dBm 75 Ω	0	0	0	1	0	0	0	1	0	1	1	0	1	0	0	0
Option 005	+ 26.99 dBm 50 Ω	0	0	1	0	0	1	1	0	1	0	0	1	1	0	0	1
Option H15	+ 25.23 dBm 75 Ω	0	0	1	0	0	1	0	1	0	0	1	0	0	0	1	1

26 { TM
C
L
KT

A7 CPU ASSEMBLY (03330-66507)

SWEEP STEP TIMER

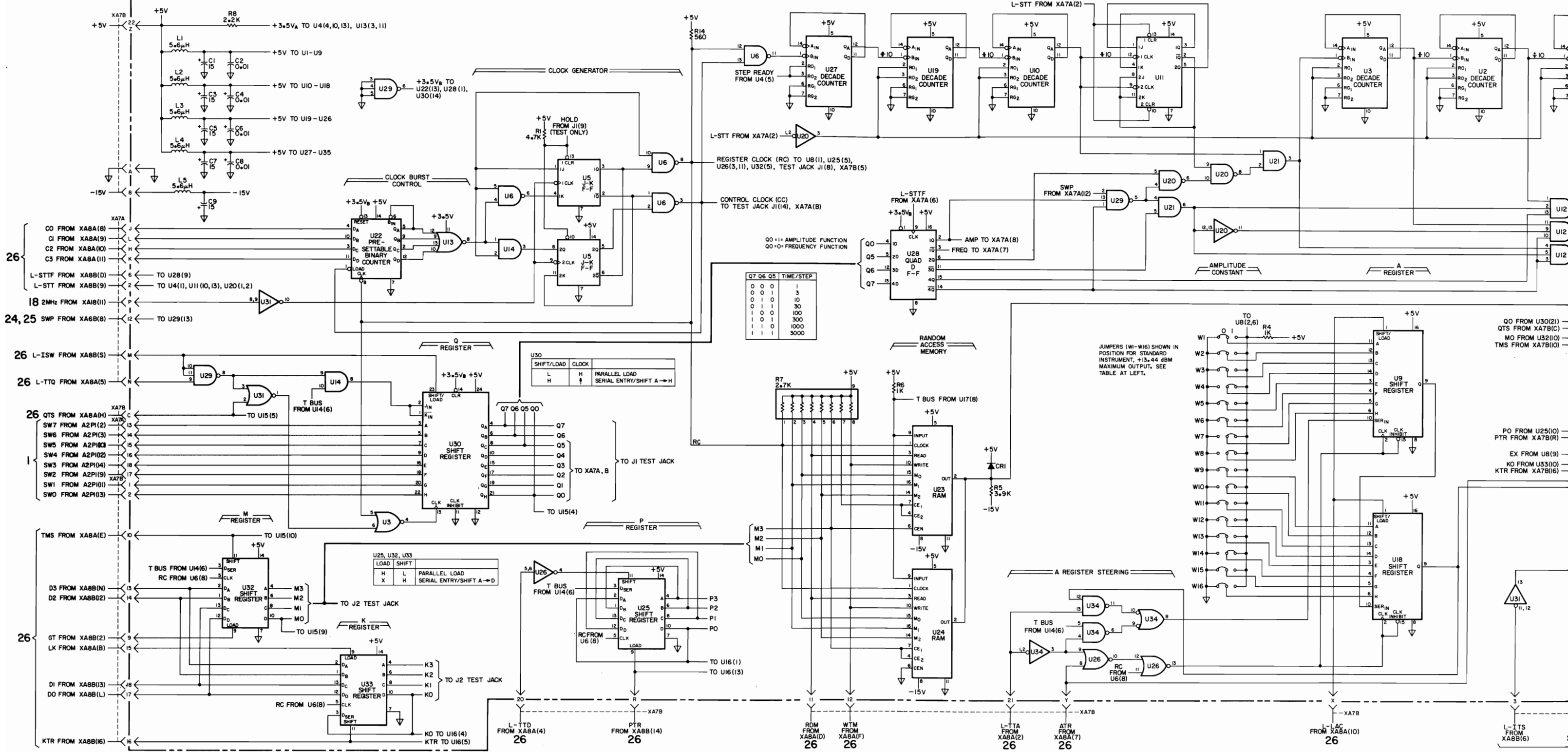

Q7	Q6	Q5	TIME/STEP
0	0	0	1
0	0	1	3
0	1	0	10
0	1	1	30
1	0	0	100
1	0	1	300
1	1	0	1000
1	1	1	3000

U30	SHIFT/LOAD	CLOCK
L	H	PARALLEL LOAD
H	↑	SERIAL ENTRY/SHIFT A → H

U25, U32, U33	LOAD	SHIFT
H	L	PARALLEL LOAD
X	H	SERIAL ENTRY/SHIFT A → D

JUMPERS (W1-W16) SHOWN IN POSITION FOR STANDARD INSTRUMENT, +13.44 dBm MAXIMUM OUTPUT, SEE TABLE AT LEFT.

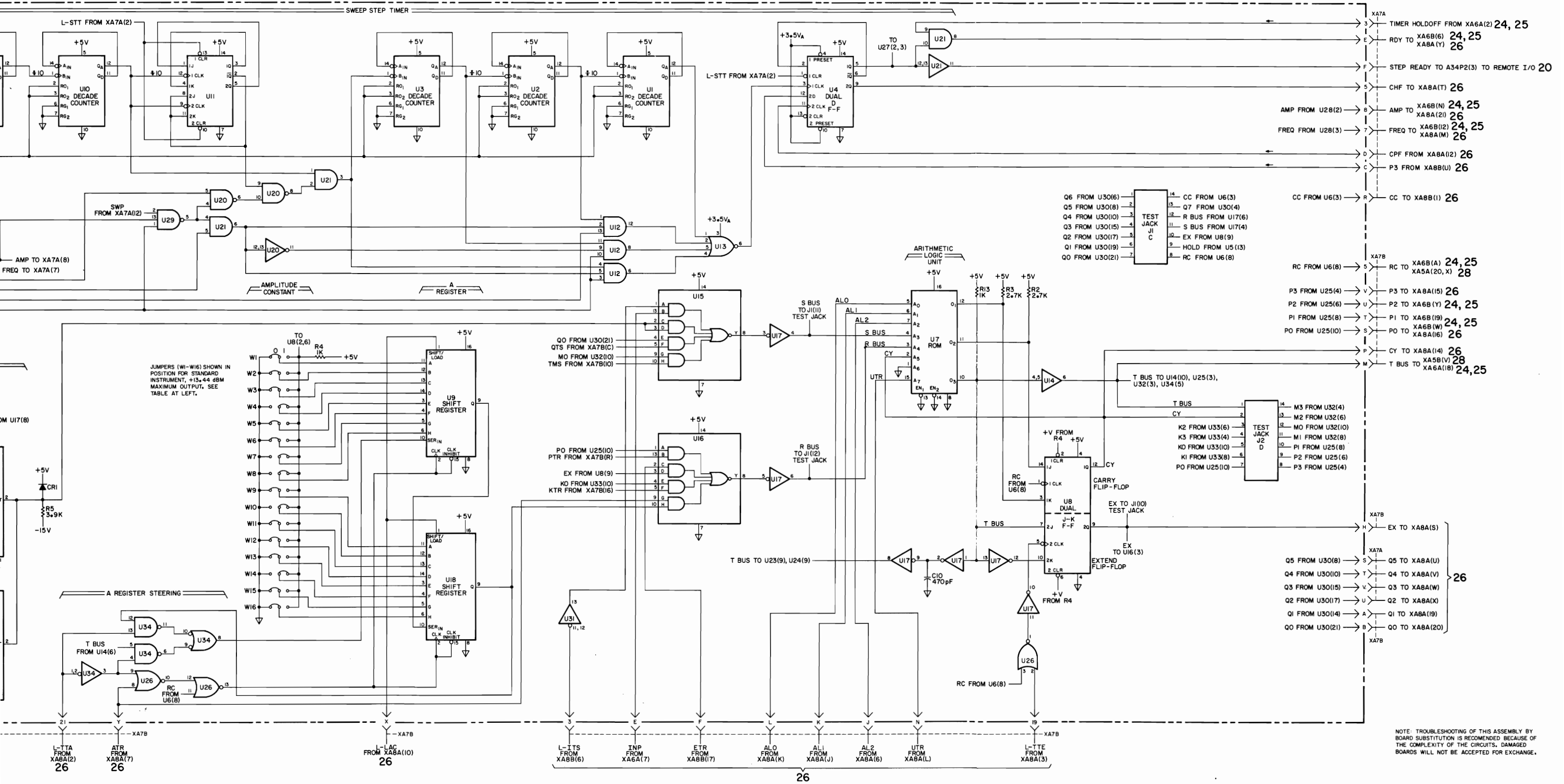

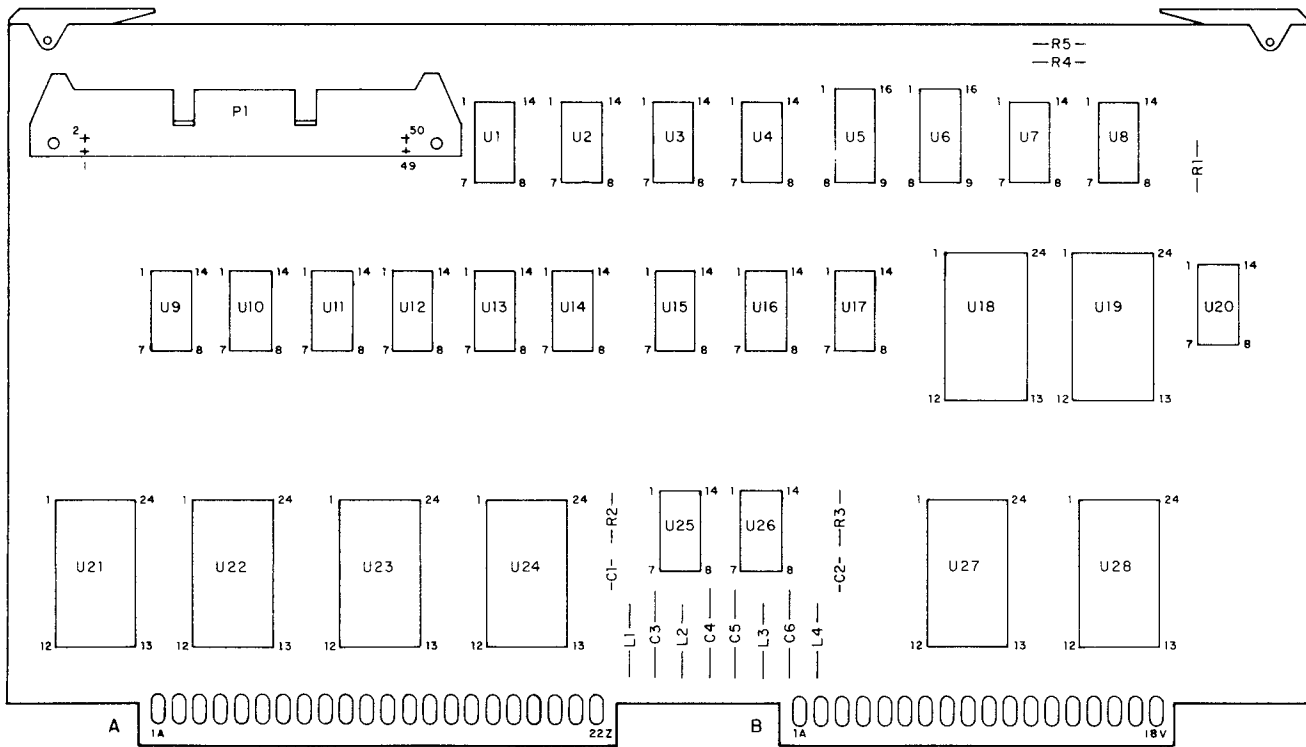

27 T BUS FRC

24, 25 L-A STEP FRC

24, 25 L-DBM FRC

26 L-OTAD FRC

26 OTDL FRC

26 L-TTO FRC

27 RC FRC

3330-B-4761

A5
03330-66505

26 L-OTAC FRC
L-OTFC FRC
L-TTO FRC

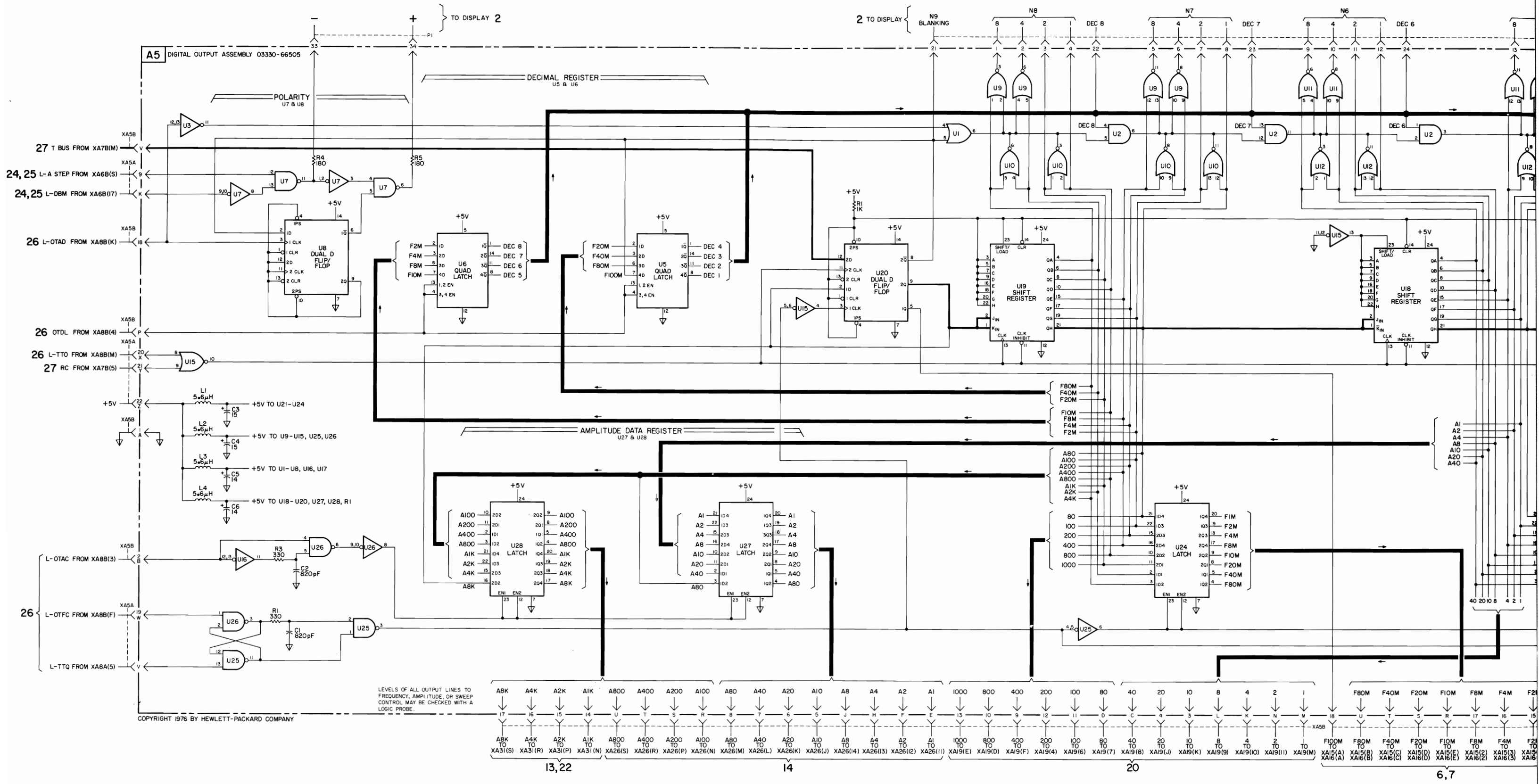

13,22

14

20

6,7

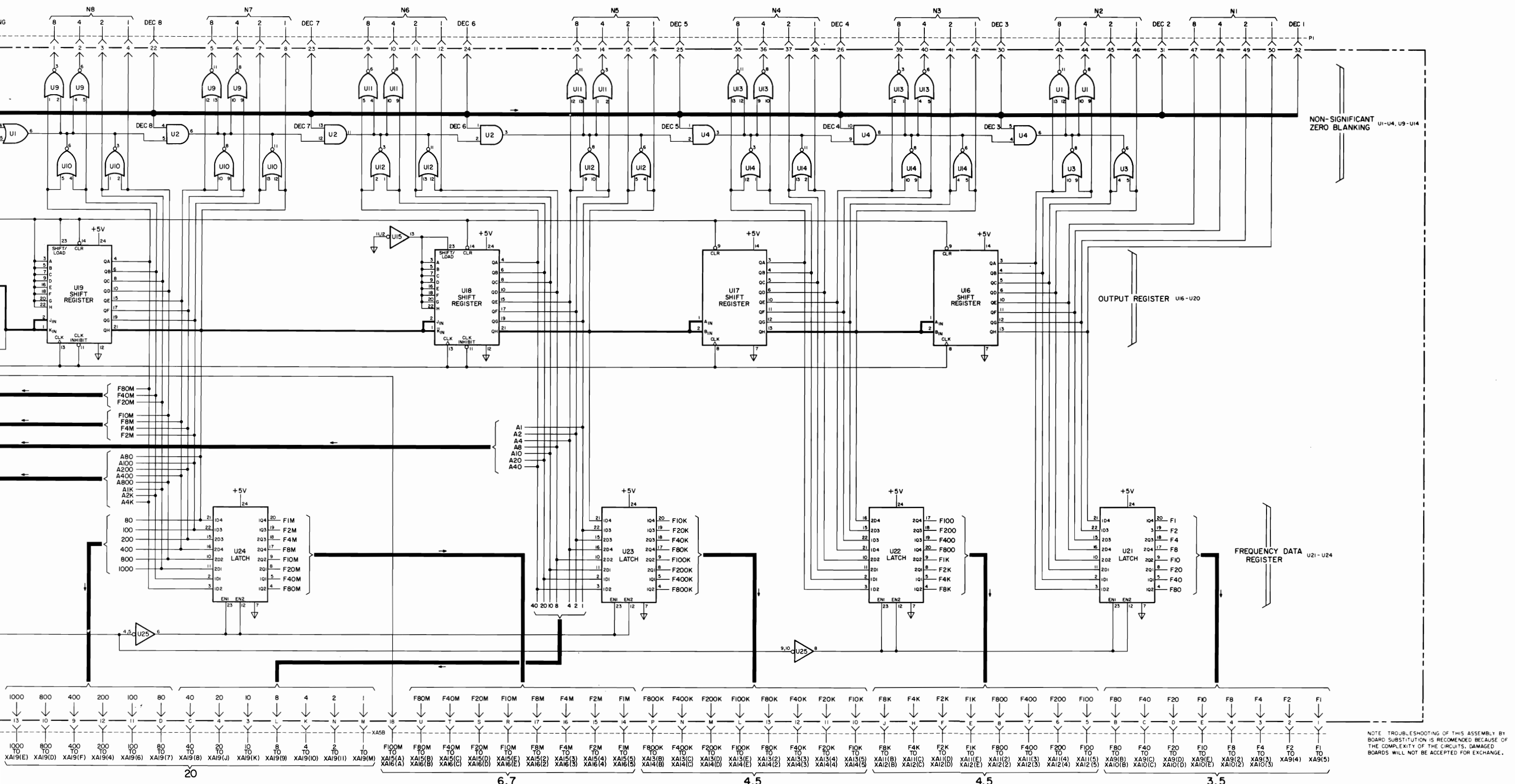
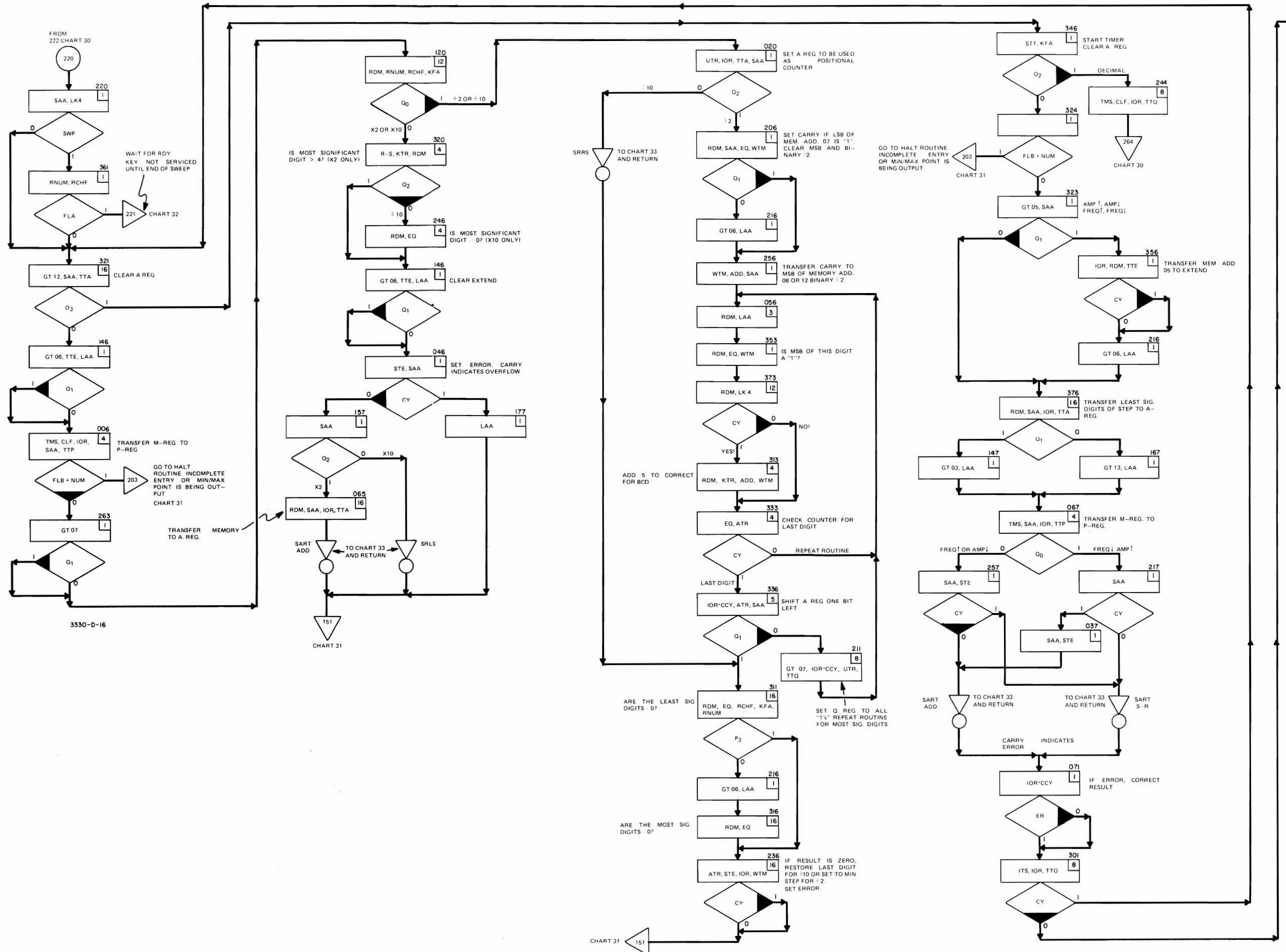

Figure 7-34. Logic Output Assembly, A5.
7-103/7-104



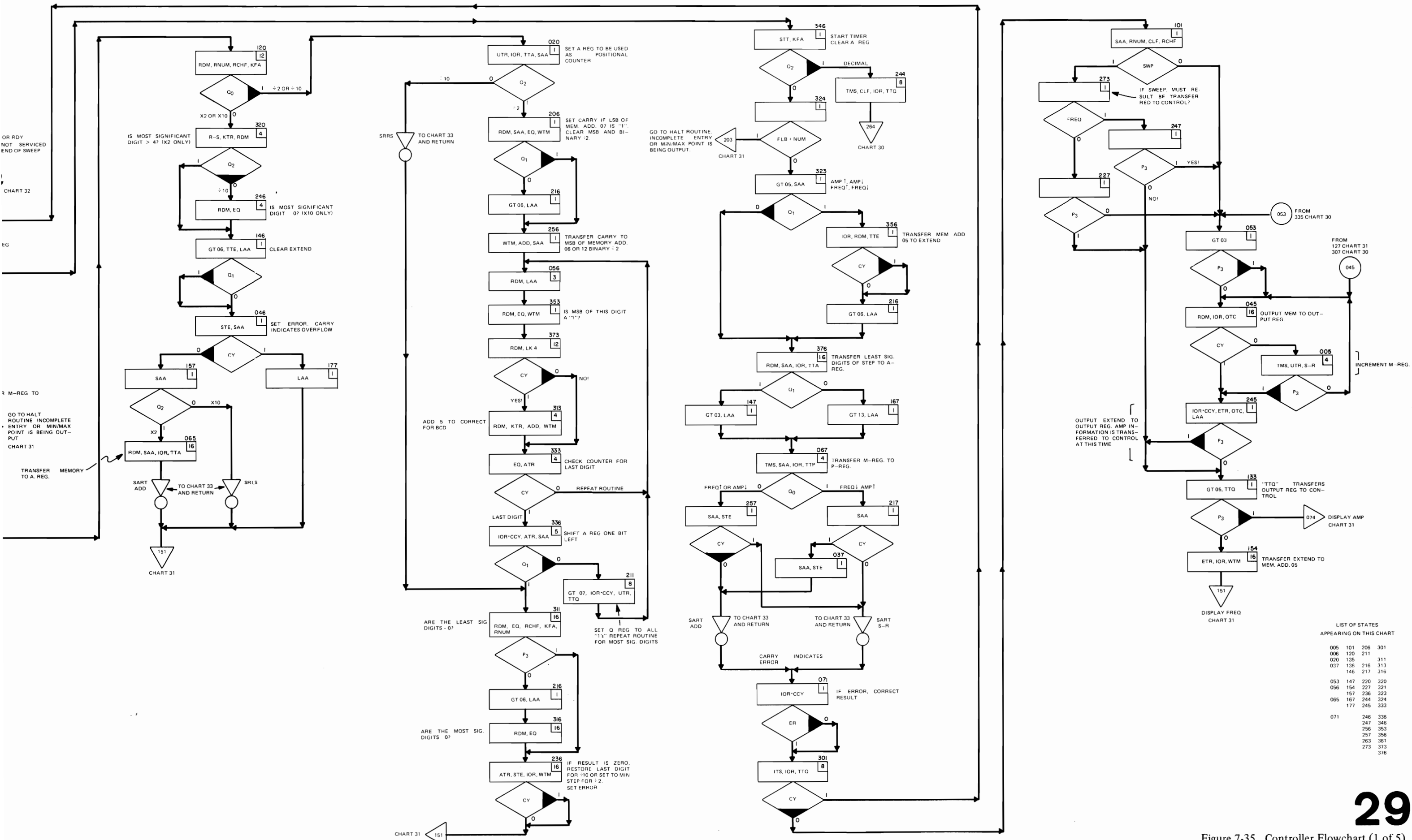
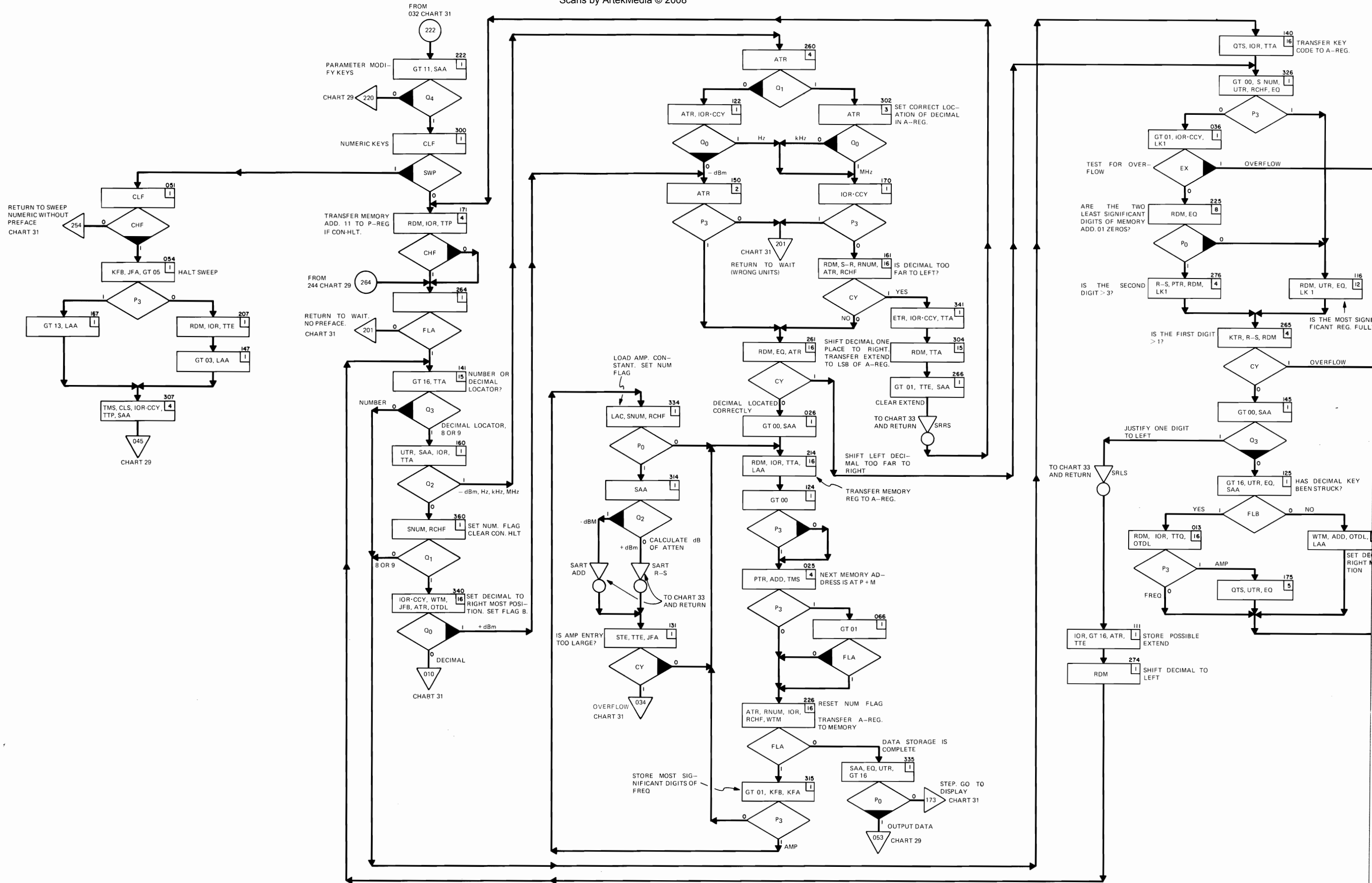
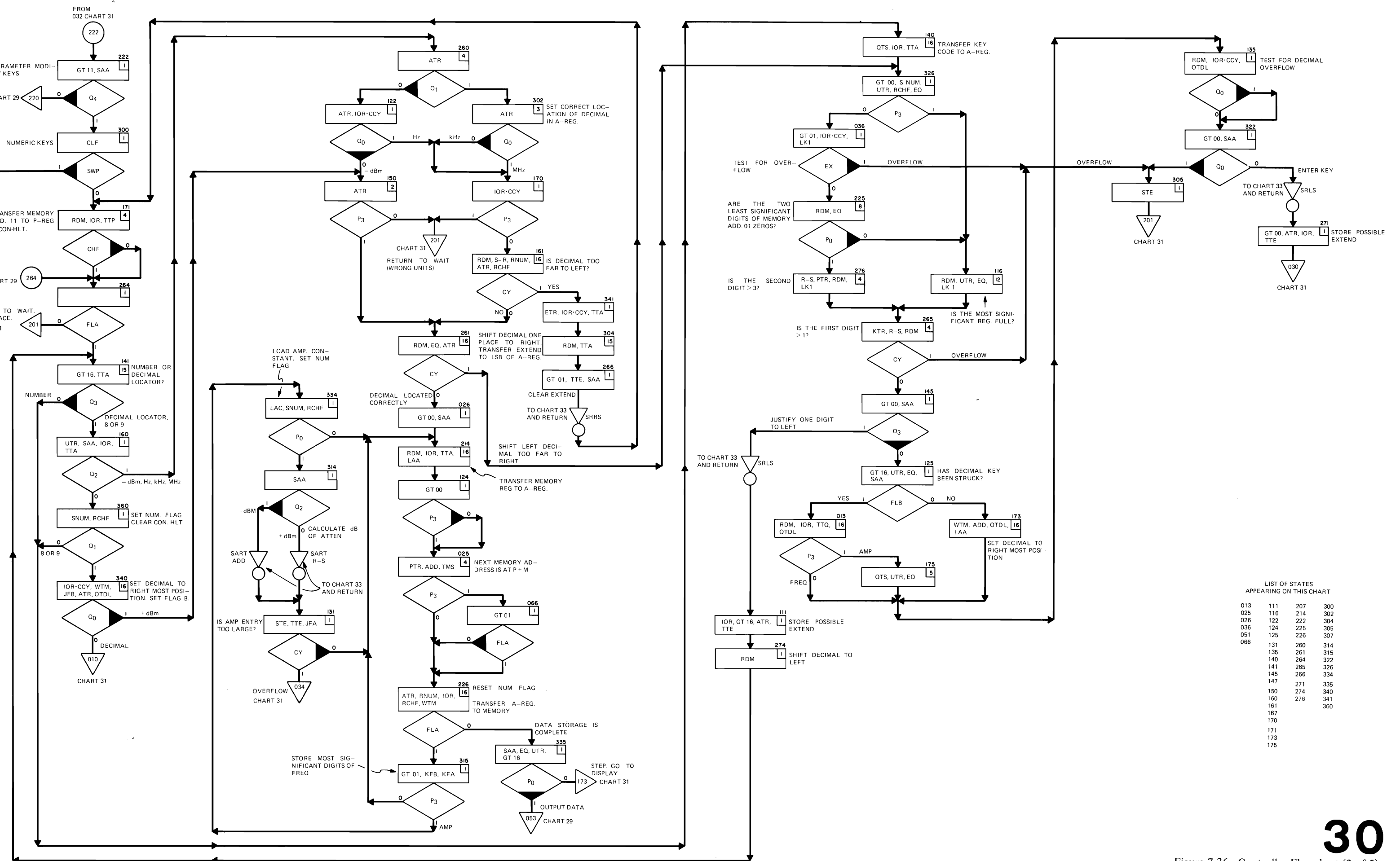

Figure 7-35. Controller Flowchart (1 of 5).
7-105/7-106





LIST OF STATES APPEARING ON THIS CHART

013	111	207	300
025	116	214	302
026	122	222	304
036	124	225	305
051	125	226	307
066			
131	260	314	
135	261	315	
140	264	322	
141	265	326	
145	266	334	
147	271	335	
150	274	340	
160	276	341	
161			360
167			
170			
171			
173			
175			

Figure 7-36. Controller Flowchart (2 of 5).
7-107/7-108

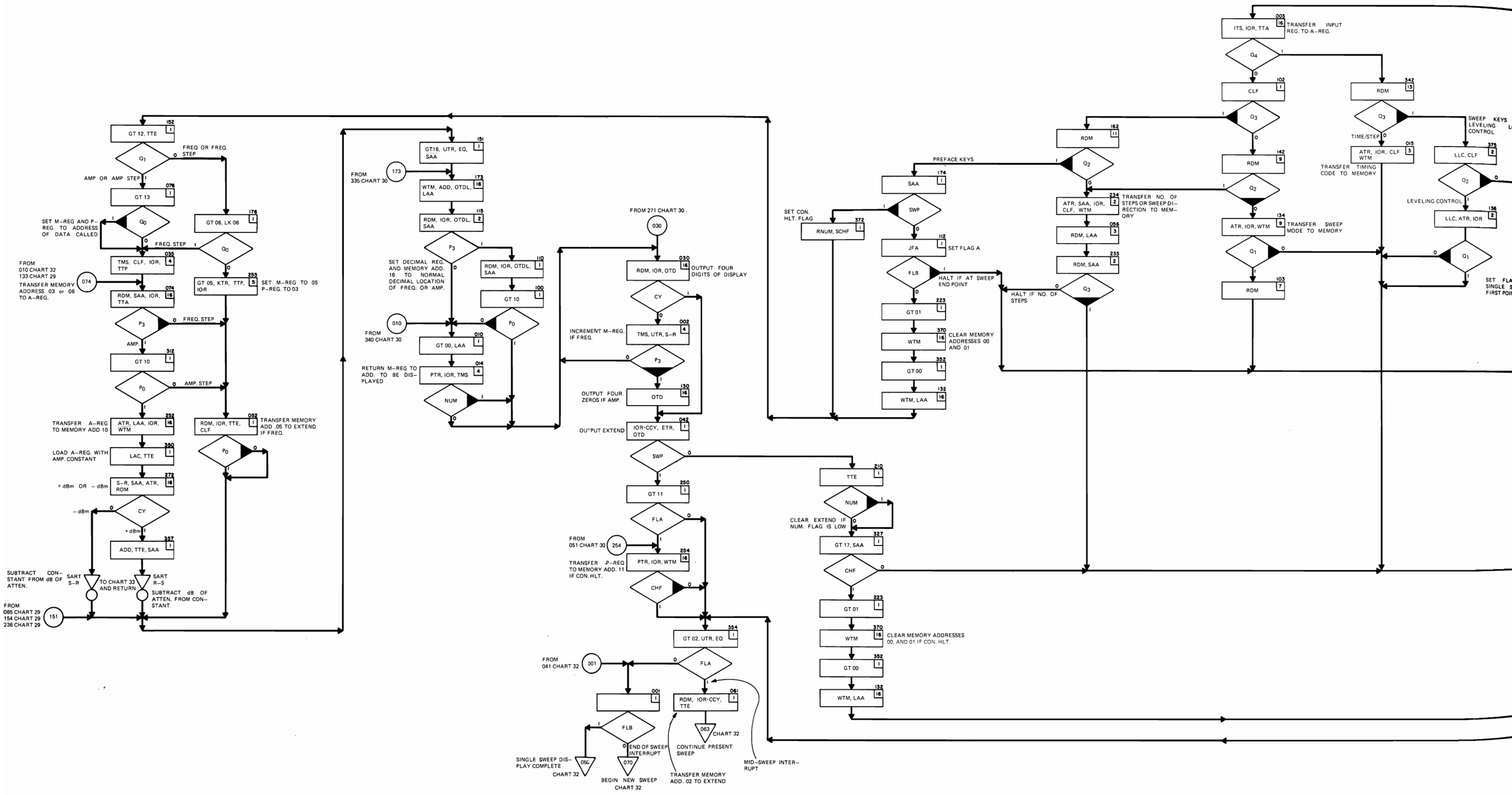

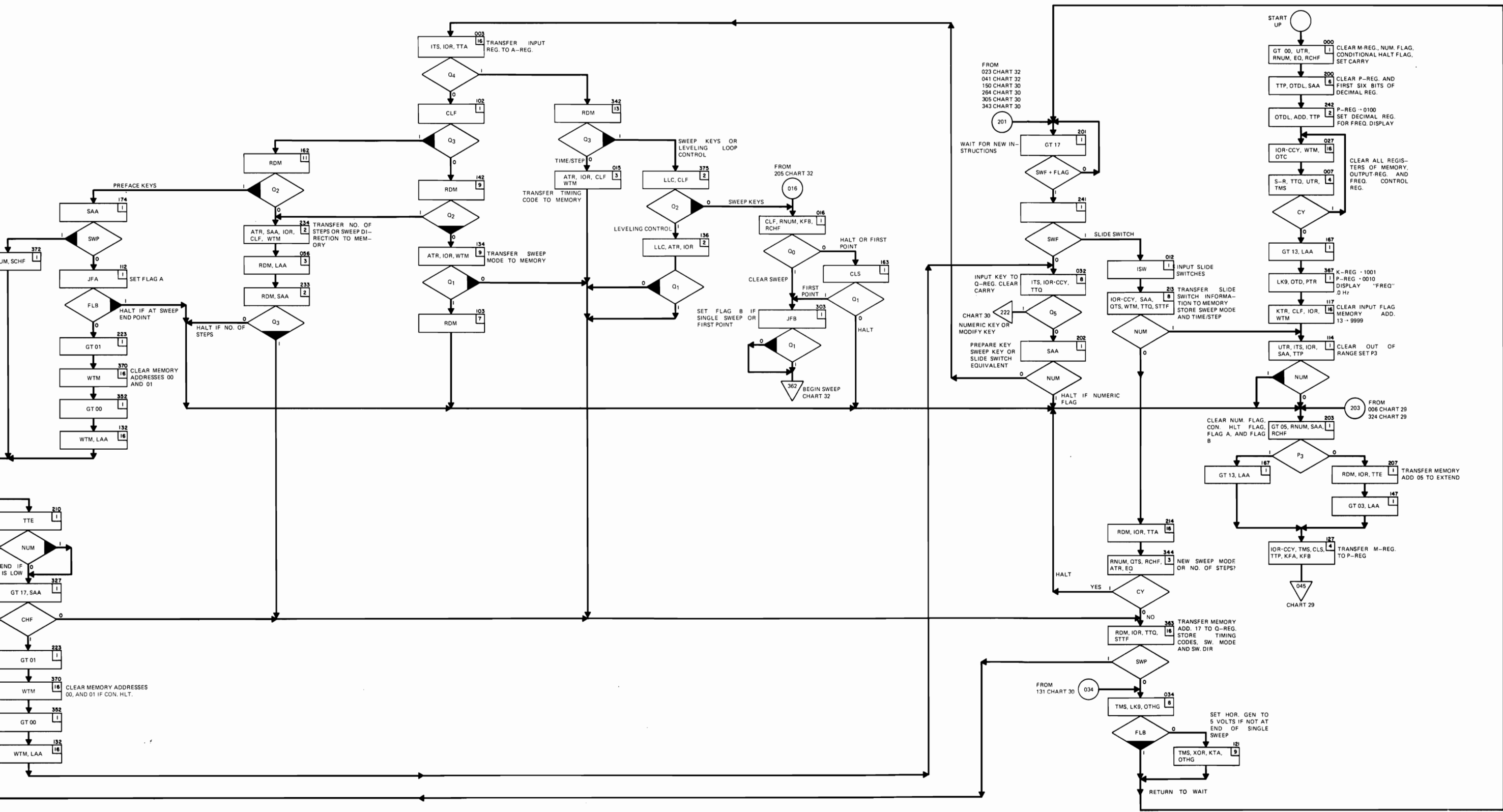

- LIST OF STATES APPEARING ON THIS CHART
- 000 100 200 303
 - 001 102 201
 - 002 103 202 312
 - 003 110 203
 - 007 112 207 327
 - 010 114 210 342
 - 012 115
 - 014 121 213 344
 - 015 127 214 350
 - 016 130 223 352
 - 025 132 233 354
 - 026 134 234 357
 - 027 136 241 363
 - 030 142 242 367
 - 032 147 250 370
 - 034 151 252 372
 - 035 152 254 375
 - 042 162 255
 - 052 163
 - 056 167 272
 - 061 173
 - 074 174
 - 076 176

Figure 7-37. Controller Flowchart (3 of 5). 7-109/7-110

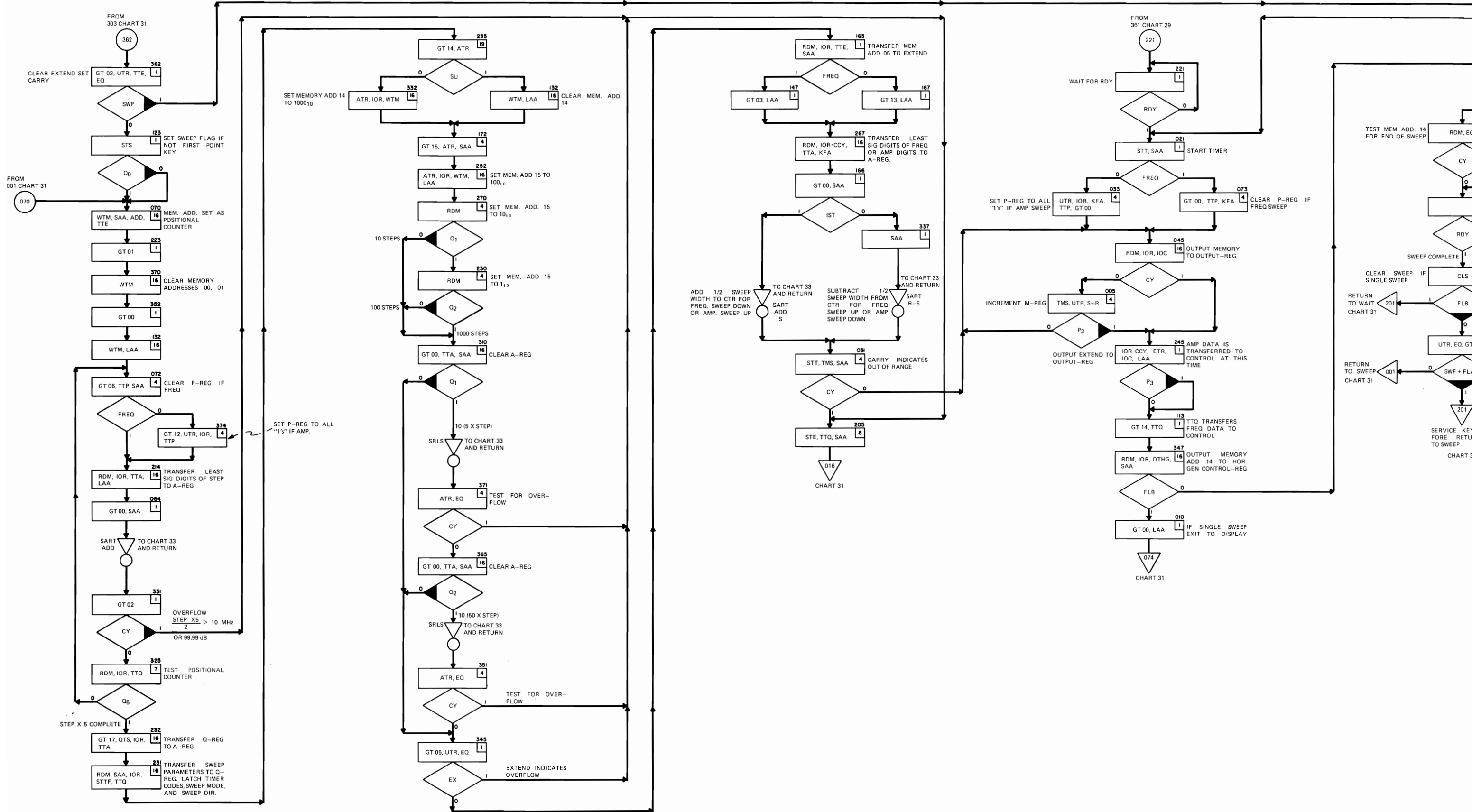

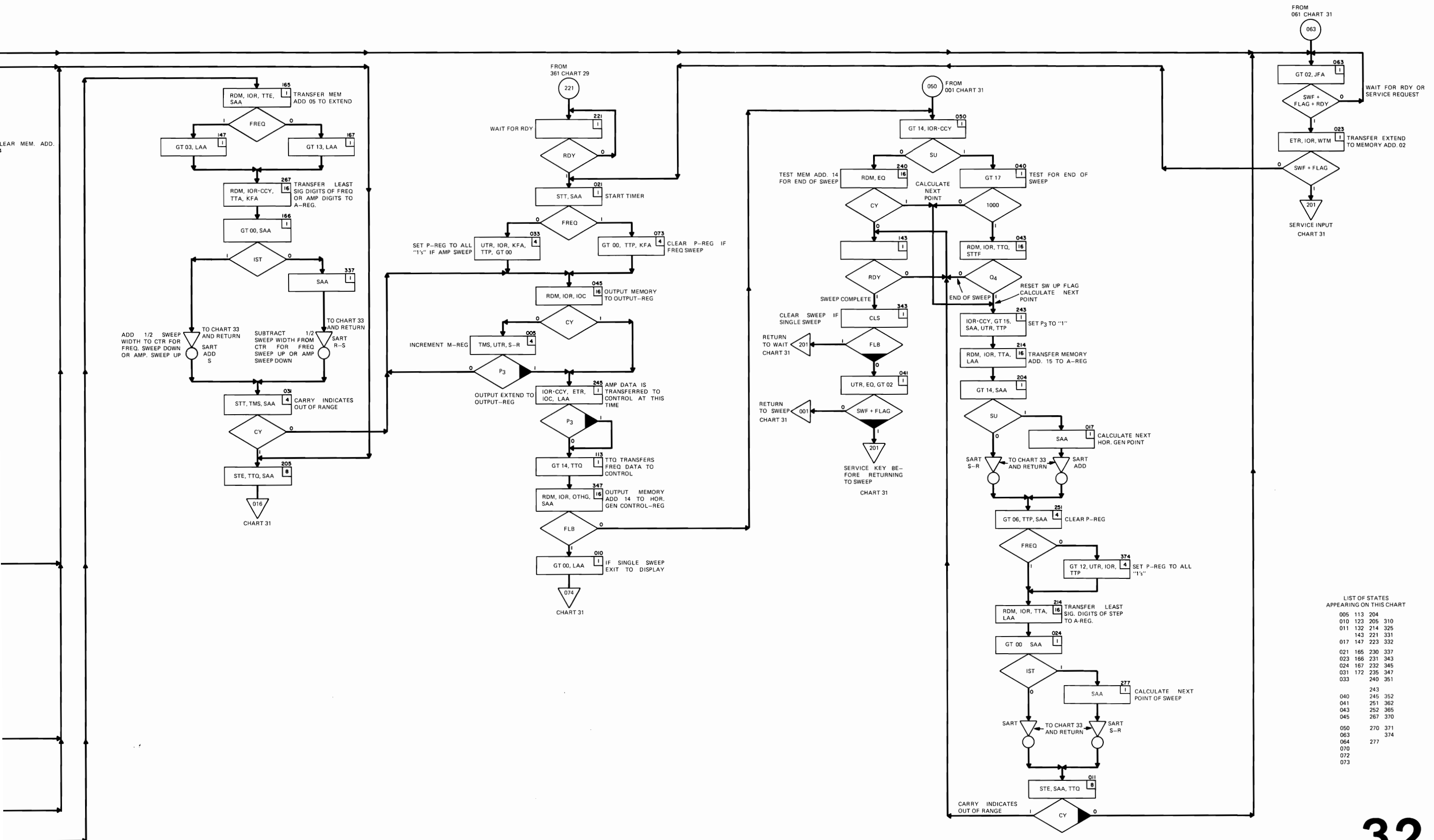

LIST OF STATES APPEARING ON THIS CHART

005	113	204
010	123	205
011	132	214
017	147	223
021	165	230
023	166	231
024	167	232
031	172	235
033	240	351
243		
040	245	352
041	251	362
043	252	365
045	267	370
050	270	371
063		374
064		277
070		
072		
073		

Figure 7-38. Controller Flowchart (4 of 5).
7-111/7-112

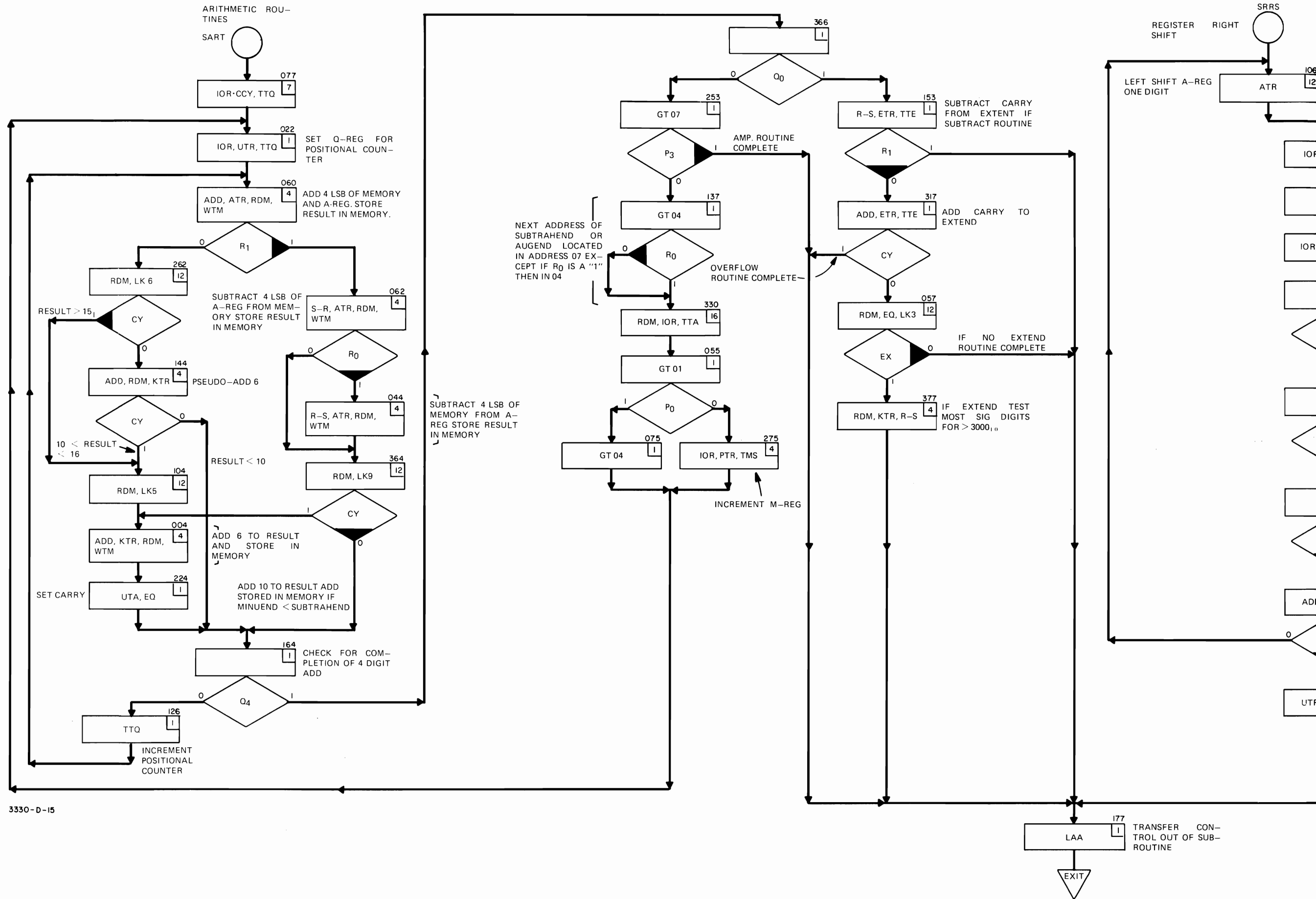

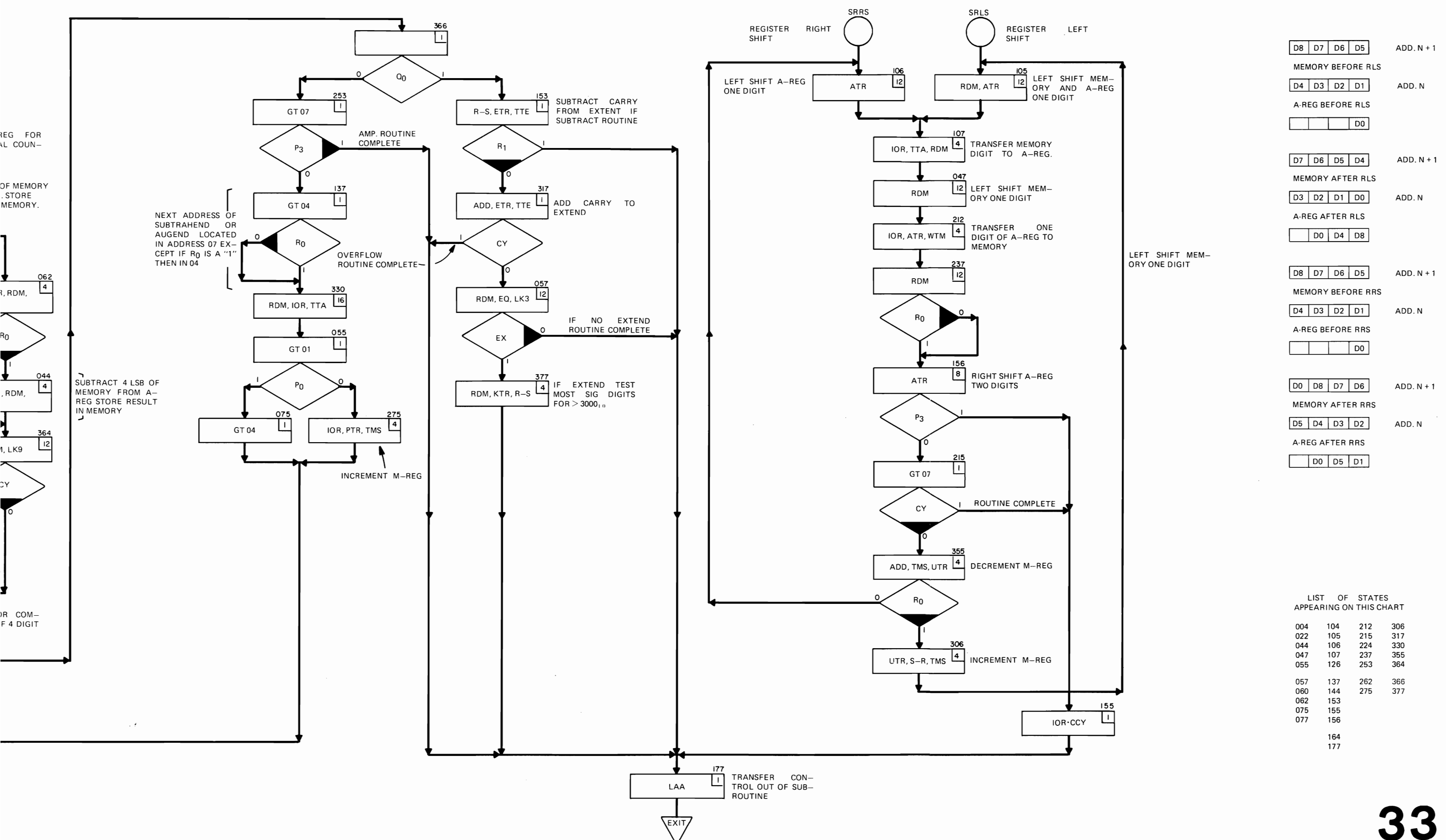

Figure 7-39. Controller Flowchart (5 of 5). 7-113/7-114

SECTION VIII BACKDATING

8-1. INTRODUCTION.

8-2. This section contains backdating information which adapts this manual to instruments with serial numbers lower than those shown on the title page. Backdating changes are denoted in the Replaceable Parts List and on the schematic diagrams by a numbered delta (Δ_1) which corresponds to the change number in this section.

8-3. Only those changes which cannot be adapted to earlier instruments or which do not benefit the operation of earlier instruments are listed in this section. If a component value or part number differs from that shown in the Replaceable Parts List, yet is not listed in this section, the value and part number listed in the Replaceable Parts List should be used if replacement is necessary.

8-4. BACKDATING CHANGES.

- Δ_1 **8-5. Change No. 1 for 3330A Serial Numbers 1145A00112 and Lower; 3330B Serial Numbers 1144A00135 and Lower.**

Table 6-1 and Schematic No. 8: Delete A21C22
Table 6-1 and Schematic No. 10: Delete A23C24

- Δ_2 **8-6. Change No. 2 for 3330A Serial Numbers 1145A00112 and Lower; 3330B Serial Numbers 1144A00210 and Lower.**

Table 6-1 and Schematic No. 21: Delete A35C14

- Δ_3 **8-7. Change No. 3 for 3330A Serial Numbers 1145A00122 and Lower; 3330B Serial Numbers 1144A00260 and Lower.**

In instruments with these serial numbers and lower, the A8 Control Assembly was Part No. 03330-66508, and the following Part Numbers were used for A6, Digital Input Assembly.

3330A Standard	03330-66573
3330A Option 004	03330-66574
3330B Standard	03330-66506
3330B Option 004	03330-66563

These part numbers are no longer available, and the part numbers shown in Table 6-1 must be used for board replacement. For additional information, contact your nearest Hewlett-Packard Sales and Service Office, listed in the back of this manual. Refer to Service Note 3330A/B-7.

- Δ_4 **8-8. Change No. 4 for 3330A Serial Numbers 1145A00122 and Lower; 3330B Serial Numbers 1305A00360 and Lower.**

Table 6-1 (under 03330-66576 and 03330-66578) and Schematic No. 24: Delete A6R8 and A6R9

- Δ_5 **8-9. Change No. 5 for 3330A Serial Numbers 1145A00128 and Lower; 3330B Serial Number 1313A00445 and Lower.**

Table 6-1 and Schematic No. 21: Delete A36C12

- Δ_6 **8-10. Change No. 6 for 3330A Serial Numbers 1145A00132 and Lower; 3330B Serial Numbers 1313A00485 and Lower.**

Table 6-1 (under 03330-66577 and 03330-66579):
Add: A60IS1, 1990-0400, Photo Isolator
A6Q1, 1854-0354, TSTR: SI NPN
A6R22, R35, 0684-1021, R:fxd 1000 ohms 10%
Change: A6R9 to 0698-3487, R:fxd 255 ohms 1%
A60IS1, A6Q1, A6R22, and A6R35 were deleted in instruments with serial numbers higher than these because of erratic delay information when operating with the Model 3570A.

- Δ_7 **8-11. Change No. 7 for 3330A Serial Numbers 1301A00152 and Lower; 3330B Serial Number 1313A00460 and Lower.**

Table 6-1 and Schematic No. 21: Change A35R2 to 0727-0445, 2 ohms 1%

- Δ_8 **8-12. Change No. 8 for 3330A Serial Numbers 1301A00152 and Lower; 3330B Serial Numbers 1313A00610 and Lower.**

Table 6-1 and Schematic No. 12: Delete A30R100* and replace with CR2, 1901-0044, Diode, Silicon

- Δ_9 **8-13. Change No. 9 for 3330A Serial Numbers 1301A00162 and Lower; 3330B Serial Numbers 1313A00610 and Lower.**

Table 6-1 and Schematic No. 12: Delete A30C40, C41

- Δ_{10} **8-14. Change No. 10.**

The use of Power Input Module, Part No. 5060-1188 has been discontinued, and this part has been

replaced by Part No. 0960-0443. The principal difference is the method of selecting operating voltages. If it is necessary to replace this module in an older instrument, the following list shows the wire connections to the new module. See Figure 2-1 for voltage selection.

Wire Color	Wire Connection	
	Old Module 5060-1188	New Module 0960-0443
GRA	2	B
BLK (to power Xfmr)	3	C
BLK/GRN	4	D
BLK/YEL (to Opt 004 Xfmr)	4	C
BLK/YEL (to power Xfmr)	7	E
WHT/YEL/GRA	7	J
BLK/RED	6	F
GRN/YEL		G (solder lug)
BLK (to Opt 004 Xfmr)	6	E
		J
WHT/BLK		to
		N
WHT/BRN/GRA		L
WHT/GRA (to Blower)		D

plied with instruments below these serial numbers. This kit may now be ordered with the instrument as Option 908, or purchased at a later date under Part No. 5060-8741.

Δ12 8-16. Change No. 12 for 3330B Serial Numbers 1313A01160 and Lower.

Table 6-1 and Schematic No. 19: Delete A17F1

Δ13 8-17. Change No. 13 for 3330B Serial Numbers 1313A01255 and Lower.

Page 6-23, Table 6-1. Change part number of A21 to 03330-66518.

Page 6-24, Table 6-1. Change A21IC9 to 1816-0040 ROM, bipolar. Change A23 to 03330-66519.

Page 6-25, Table 6-1. Change A23IC8 to 1816-0040 ROM, bipolar.

Page 6-29, Table 6-1. Change A27 to 03330-66518.

Δ11 8-15. Change No. 11 for 3330A Serial Numbers 1301A00203 and Lower; 3330B Serial Numbers 1313A01021 and Lower.

Rack mounting kit, Part No. 03330-84401, was sup-

Δ14 8-18. Change No. 14 for 3330A and for 3330B Serial Numbers 1313A01305 and Lower.

Page 6-2, Table 6-1. Replace the parts list for A1 with the following list.

Reference Designation	HP Part Number	Qty	Description	Mfr Code	Mfr Part Number
A18 (B ONLY)	03330-66501	1	PC ASSY: KEYBOARD (IDENTICAL TO A1A)	28480	03330-66501
A1A (A ONLY)	03330-66557	1	PC ASSY: KEYBOARD	28480	03330-66567
A1C1	0160-0168	2	C:FXD MY 0.1 UF 10% 200VDCW	56289	192P10492-PTS
A1C2	0160-0362	3	C:FXD MICA 510PF 5%	28480	0160-0362
A1C3	0180-0197	2	C:FXD ELECT 2.2 UF 10% 20VDCW	56289	1500225X9020A2-DYS
A1C4	0150-0093	134	C:FXD CER 0.01 UF +80-20% 100VDCW	72982	801-K800011
A1C11	1901-0044	5	DIODE:SILICON 20MA/1V	28480	1901-0044
A1C11	1820-0657	2	IC:DIGITAL TTL 8-INPT PRIORITY ENCODER	07263	U78931859X
A1C12	1820-0077	2	IC:TTL DUAL D F/F	01295	SN7474N
A1C13	1820-0657		IC:DIGITAL TTL 8-INPT PRIORITY ENCODER	07263	U78931859X
A1C14	1820-0207	4	IC:TTL MONOSTABLE MULTIVIBRATOR	28480	1820-0207
A1R1	0683-5125	21	R:FXD COMP 5100 OHM 5% 1/4W	01121	CB 5125
A1R2	0683-5125		R:FXD COMP 5100 OHM 5% 1/4W	01121	CB 5125
A1R3	0683-5125		R:FXD COMP 5100 OHM 5% 1/4W	01121	CB 5125
A1R4	0683-5125		R:FXD COMP 5100 OHM 5% 1/4W	01121	CB 5125
A1R5	0683-5125		R:FXD COMP 5100 OHM 5% 1/4W	01121	CB 5125
A1R6	0683-5125		R:FXD COMP 5100 OHM 5% 1/4W	01121	CB 5125
A1R7	0583-5125		R:FXD COMP 5100 OHM 5% 1/4W	01121	CB 5125
A1R8	0683-5125		R:FXD COMP 5100 OHM 5% 1/4W	01121	CB 5125
A1R9	0583-5125		R:FXD COMP 5100 OHM 5% 1/4W	01121	CB 5125
A1R10	0683-5125		R:FXD COMP 5100 OHM 5% 1/4W	01121	CB 5125
A1R11	0683-5125		R:FXD COMP 5100 OHM 5% 1/4W	01121	CB 5125
A1R12	0683-5125		R:FXD COMP 5100 OHM 5% 1/4W	01121	CB 5125
A1R13	0683-5125		R:FXD COMP 5100 OHM 5% 1/4W	01121	CB 5125
A1R14	0683-4735	8	R:FXD COMP 47K OHM 5% 1/4W	01121	CB 4735
A1R15	0583-5125		R:FXD COMP 5100 OHM 5% 1/4W	01121	CB 5125
A1R16	0686-1025	1	R:FXD COMP 1000 OHM 5% 1/2W	01121	EB 1025
A1W1			NOT ASSIGNED		
A1W2			NOT ASSIGNED		
A1W3	03330-61601	2	CABLE ASSY:FLAT	28480	03330-61601

Page 6-48 and 6-49, Table 6-1. Replace the parts list for the keys, MP45, with the following list.

Reference Designation	HP Part Number	Qty	Description	Mfr Code	Mfr Part Number	
MP45	0370-2202		KEYBOARD KEYS (INCLUDE THE FOLLOWING)	28480	0370-2202	
	0370-2203		KEY:FREQ	28480	0370-2203	
	0370-2204		KEY:FREQ STEP	28480	0370-2204	
	0370-2205		KEY:AMPL	28480	0370-2205	
	0370-2206		KEY:AMPL STEP	28480	0370-2206	
			KEY:0 (B ONLY)	28480	0370-2206	
		0370-2207		KEY:0 (A ONLY)	28480	0370-2207
		0370-2208		KEY:1	28480	0370-2208
		0370-2209		KEY:2	28480	0370-2209
		0370-2210		KEY:3	28480	0370-2210
		0370-2211		KEY:4	28480	0370-2210
		0370-2212		KEY:5	28480	0370-2212
		0370-2213		KEY:6	28480	0370-2213
		0370-2214		KEY:7	28480	0370-2214
		0370-2215		KEY:8	28480	0370-2215
		0370-2216		KEY:9	28480	0370-2216
		0370-2217		KEY:· (B ONLY)	28480	0370-2217
		0370-2218		KEY:· (A ONLY)	28480	0370-2218
		0370-2219		KEY:+ DBM (B ONLY)	28480	0370-2219
		0370-2220		KEY:- DBM (B ONLY)	28480	0370-2220
		0370-2221		KEY:H7	28480	0370-2221
		0370-2222		KEY:KHZ	28480	0370-2222
		0370-2223		KEY:MHZ	28480	0370-2223
		0370-2224		KEY:FREQ DIV 2	28480	0370-2224
		0370-2225		KEY:FREQ DIV 10	28480	0370-2225
		0370-2226		KEY:FREQ UP	28480	0370-2226
		0370-2227		KEY:FREQ X 2	28480	0370-2227
		0370-2228		KEY:FREQ X 10	28480	0370-2228
		0370-2229		KEY:FREQ DN	28480	0370-2229
		0370-2230		KEY:AMPL DIV 2 (B ONLY)	28480	0370-2230
		0370-2231		KEY:AMPL DIV 10 (B ONLY)	28480	0370-2231
		0370-2232		KEY:AMPL UP (B ONLY)	28480	0370-2232
		0370-2233		KEY:AMPL X 2 (B ONLY)	28480	0370-2233
		0370-2234		KEY:AMPL X 10 (B ONLY)	28480	0370-2234
		0370-2235		KEY:AMPL DN (B ONLY)	28480	0370-2235
		0370-2236		KEY:1ST POINT	28480	0370-2236
		0370-2237		KEY:START SGL	28480	0370-2237
		0370-2238		KEY:START CONT	28480	0370-2238
		0370-2239		KEY:STOP	28480	0370-2239

Page 7-23/7-24, Figure 7-6. Replace Schematic Diagram No. 1 with Figure 8-1.

NOTE

If the entire keyboard assembly must be replaced in a 3330B Serial No. 1313A01255 or lower, order Modification Kit, -hp- Part No. 03330-84412.

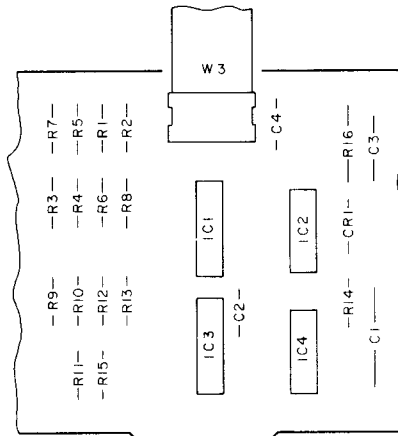

3330A-B-2800

AIB

hp Part No 03330-66501

AIA

hp Part No 03330-66567

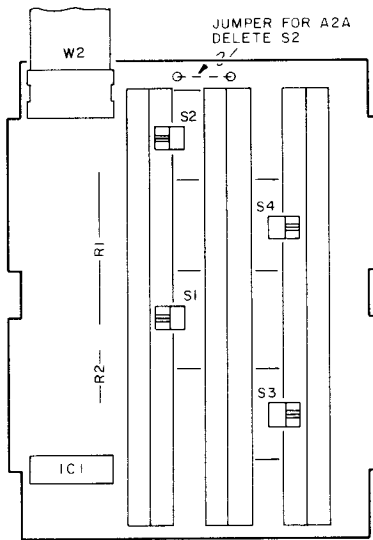

3330A-B-2799

A2B

hp Part No 03330-66502

A2A

hp Part No 03330-66568

A1B KEYBOARD 03330-66501 (B Model)

A1A KEYBOARD 03330-66567 (A Model)

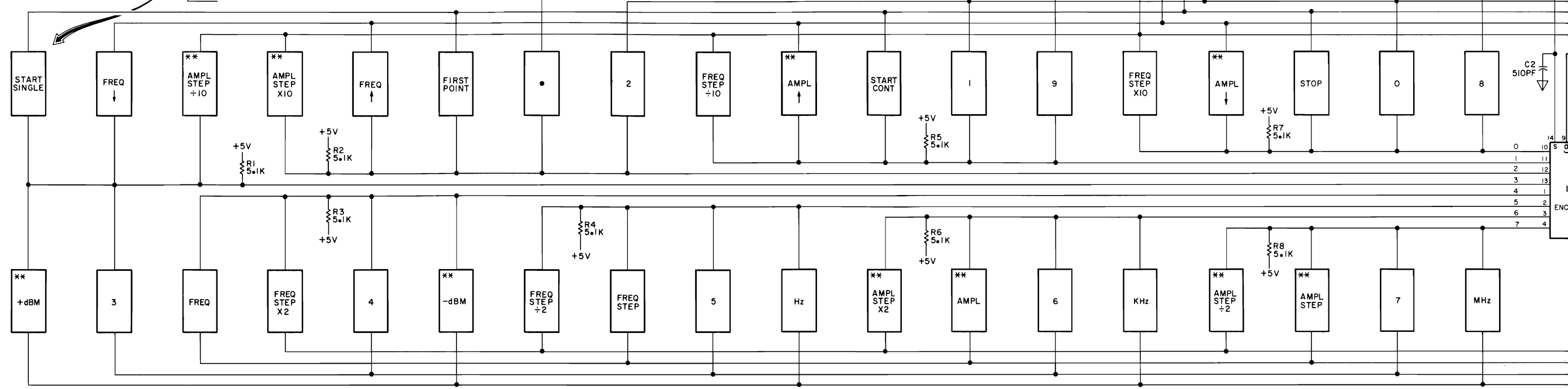
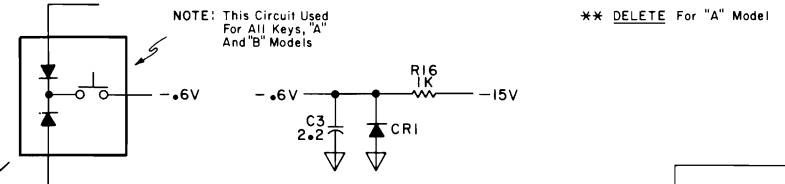

NOTE 1
 03330-66576 (3330B STANDARD)
 03330-66577 (3330B OPTION 004)
 03330-66578 (3330B STANDARD)
 03330-66579 (3330B OPTION 004)

A2B SLIDE SWITCH 03330-66502 (B Model)

A2A SLIDE SWITCH 03330-66568 (A Model)

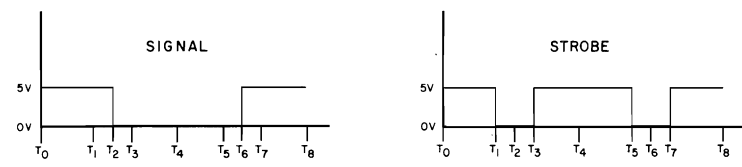
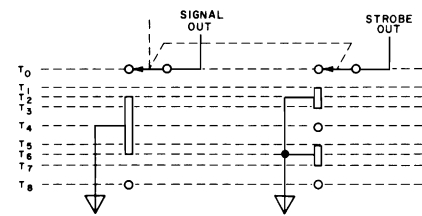

SIGNAL TIMING DIAGRAM Example

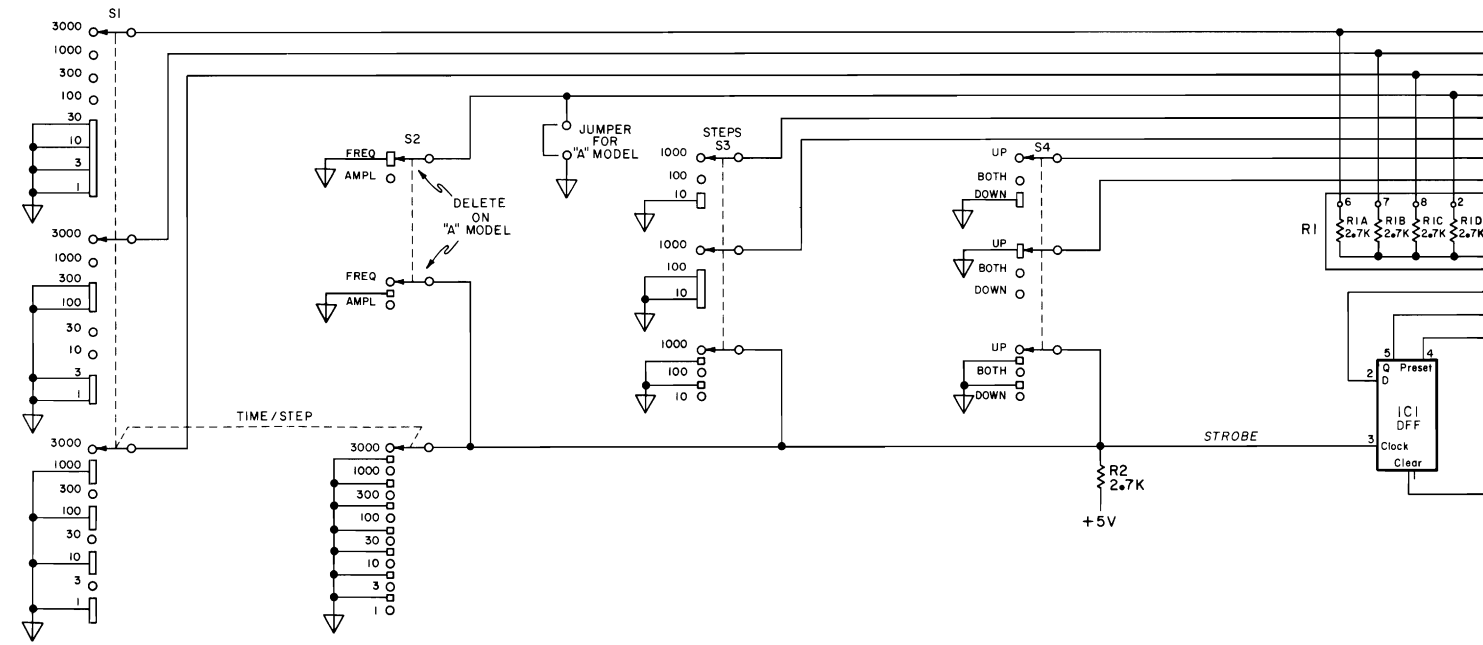

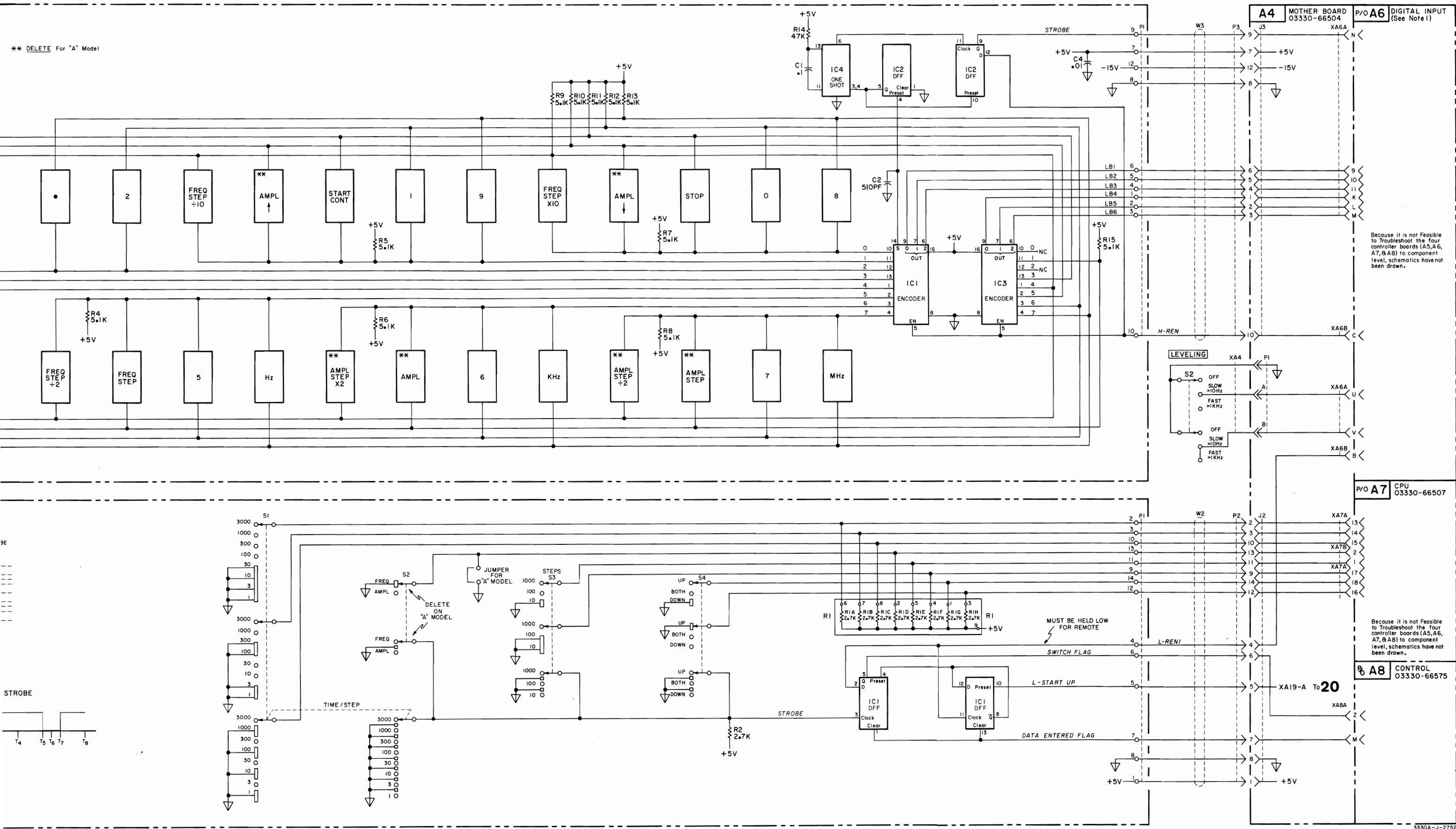

Because it is not feasible to troubleshoot the four controller boards (A5, A6, A7, B A8) to component level, schematics have not been drawn.

Because it is not feasible to troubleshoot the four controller boards (A5, A6, A7, B A8) to component level, schematics have not been drawn.

Because it is not feasible to troubleshoot the four controller boards (A5, A6, A7, B A8) to component level, schematics have not been drawn.

Serial Numbers 1313A01305 and Lower
 Figure 8-1. Keyboard A1A, A1B Slide Switch A2A, A2B.
 8-5/8-6

CODE LIST OF MANUFACTURERS

The following code numbers are from the Federal Supply Code for Manufacturers Cataloging Handbooks H4-1 (Name to Code) and H4-2 (Code to Name) and their latest supplements. The date of revision and the date of the supplements used appear at the bottom of each page. Alphabetical codes have been arbitrarily assigned to suppliers not appearing in the H4 Handbooks.

Code No.	Manufacturer	Address	Code No.	Manufacturer	Address	Code No.	Manufacturer	Address
00000	U. S. A Common	Any supplier of U.S.	05347	Ultronix, Inc.	San Mateo, Cal.	11236	CTS of Berne, Inc.	Berne, Ind.
00136	McCoy Electronics	Mount Holly Springs, Pa.	05397	Union Carbine Corp., Elect.		11237	Chicago Telephone of California, Inc.	So. Pasadena, Cal.
00213	Sage Electronics Corp.	Rochester, N. Y.	05574	Viking Ind. Inc.	Canoga Park, Cal.	11242	Bay State Electronics Corp.	Waltham, Mass.
00287	Cemco, Inc.	Danielson, Conn.	05593	Icore Electro-Plastics Inc.	Sunnyvale, Cal.	11312	Teledyne Inc., Microwave Div.	Palo Alto, Cal.
00334	Humidial	Colton, Calif.	05616	Cosmo Plastic (c/o Electrical Spec. Co.)	Cleveland, Ohio	11314	National Seal	Downey, Cal.
00348	Mictron, Co., Inc.	Valley Stream, N. Y.	05624	Barber Colman Co.	Rockford, Ill.	11453	Precision Connector Corp.	Jamaica, N. Y.
00373	Garlock Inc.	Cherry Hill, N. J.	05728	Tiffen Optical Co.	Roslyn Heights, Long Island, N. Y.	11534	Duncan Electronics Inc.	Costa Mesa, Cal.
00656	Aerovox Corp.	New Bedford, Mass.	05729	Metro-Tel Corp.	Westbury, N. Y.	11711	General Instrument Corp., Semiconductor Division Products Group	Newark, N. J.
00779	Amp. Inc.	Harrisburg, Pa.	05783	Stewart Engineering Co.	Santa Cruz, Cal.	11717	Imperial Electronic, Inc.	Buena Park, Cal.
00781	Aircraft Radio Corp.	Boonton, N. J.	05820	Wakefield Engineering Inc.	Wakefield, Mass.	11870	Melabs, Inc.	Palo Alto, Cal.
00809	Crown, Ltd.	Whitby, Ontario, Canada	06004	Bassick Co., Div. of Stewart Warner Corp.	Bridgeport, Conn.	12136	Philadelphia Handle Co.	Camden, N. J.
00815	Northern Engineering Laboratories, Inc.	Burlington, Wis.	06090	Raychem Corp.	Redwood City, Cal.	12361	Grove Mfg. Co., Inc.	Shady Grove, Pa.
00853	Sangamo Electric Co., Pickens Div.	Pickens, S. C.	06175	Bausch and Lomb Optical Co.	Rochester, N. Y.	12574	Gulton Ind. Inc., Data System Div.	Albuquerque, N. M.
00866	Goe Engineering Co.	City of Industry, Cal.	06402	E. T. A. Products Co. of America	Chicago, Ill.	12697	Clarostat Mfg. Co.	Dover, N. H.
00891	Carl E. Holmes Corp.	Los Angeles, Cal.	06540	Amatone Electronic Hardware Co., Inc.	New Rochelle, N. Y.	12728	Elmar Filter Corp.	W. Haven, Conn.
00929	Microlab Inc.	Livingston, N. J.	06555	Beebe Electrical Instrument Co., Inc.	Penacook, N. H.	12859	Nippon Electric Co., Ltd.	Tokyo, Japan
01002	General Electric Co., Capacitor Dept.	Hudson Falls, N. Y.	06666	General Devices Co., Inc.	Indianapolis, Ind.	12881	Metex Electronics Corp.	Clark, N. J.
01009	Alden Products Co.	Brockton, Mass.	06751	Components Inc., Ariz. Div.	Phoenix, Arizona	12930	Delta Semiconductor Inc.	Newport Beach, Cal.
01121	Allen Bradley Co.	Milwaukee, Wis.	06812	Torrington Mfg. Co., West Div.	Van Nuys, Cal.	12954	Dickson Electronics Corp.	Scottsdale, Arizona
01255	Litton Industries, Inc.	Beverly Hills, Cal.	06980	Varian Assoc. Etmac Div.	San Carlos, Cal.	13019	Aircor Supply Co., Inc.	Wichita, Kansas
01281	TRW Semiconductors, Inc.	Lawndale, Cal.	07088	Keivin Electric Co.	Van Nuys, Cal.	13061	Wilco Products	Detroit, Mich.
01295	Texas Instruments, Inc., Transistor Products Div.	Dallas, Texas	07126	Digitran Co.	Pasadena, Cal.	13103	Thermolloy	Dallas, Texas
01349	The Alliance Mfg. Co.	Alliance, Ohio	07137	Transistor Electronics Corp.	Minneapolis, Minn.	13327	Solihtron Devices Inc.	Tappan, N. Y.
01538	Small Parts Inc.	Los Angeles, Cal.	07138	Westinghouse Electric Corp., Electronic Tube Div.	Elmira, N. Y.	13396	Telefunken (GmbH)	Hanover, Germany
01589	Pacific Relays, Inc.	Van Nuys, Cal.	07149	Filmohm Corp.	New York, N. Y.	13835	Midland-Wright Div. of Pacific Industries, Inc.	Kansas City, Kansas
01670	Amerobrod Bros. Silk Co.	New York, N. Y.	07233	Cinch-Graphik Co.	City of Industry, Cal.	14099	Sem-Tech	Newbury Park, Cal.
01930	Amerock Corp.	Rockford, Ill.	07256	Silicon Transistor Corp.	Carle Place, N. Y.	14193	Calif. Resistor Corp.	Santa Monica, Cal.
01960	Pulse Engineering Co.	Santa Clara, Cal.	07261	Avnet Corp.	Culver City, Cal.	14298	American Components, Inc.	Conshohocken, Pa.
02114	Ferroxcube Corp. of America	Saugerties, N. Y.	07263	Fairchild Camera & Inst. Corp., Semiconductor Div.	Mountain View, Cal.	14433	ITT Semiconductor, a Div. of Int. Telephone and Telegraph Corporation	West Palm Beach, Fla.
02116	Wheelock Signals, Inc.	Long Branch, N. J.	07322	Minnesota Rubber Co.	Minneapolis, Minn.	14493	Hewlett-Packard Company	Loveland, Colo.
02286	Cole Rubber and Plastics Inc.	Sunnyvale, Cal.	07387	Birtcher Corp., The	Monterey Park, Cal.	14655	Cornell Dublier Electric Corp.	Newark, N. J.
02660	Amphenol-Borg Electronics Corp.	Broadview, Ill.	07397	Sylvania Elect. Prod. Inc., Mt. View Operations	Mountain View, Cal.	14674	Corning Glass Works	Corning, N. Y.
02735	Radio Corp. of America, Semiconductor and Materials Division	Somerville, N. J.	07700	Technical Wire Products Inc.	Cranford, N. J.	14752	Electro Cube Inc.	San Gabriel, Cal.
02771	Vocaline Co. of America, Inc.	Old Saybrook, Conn.	07829	Bodine Elect. Co.	Chicago, Ill.	14960	Williams Mfg. Co.	San Jose, Cal.
02777	Hopkins Engineering Co.	San Fernando, Cal.	07910	Continental Device Corp.	Hawthorne, Cal.	15106	The Sphere Co., Inc.	Little Falls, N. J.
02875	Hudson Tool & Die	Newark, N. J.	07933	Raytheon Mfg. Co., Semiconductor Div.	Mountain View, Cal.	15203	Webster Electronics Co.	New York, N. Y.
03296	Nylon Molding Corp.	Springfield, N. J.	07980	Hewlett-Packard Co., New Jersey Division	Rockaway, N. J.	15287	Scionics Corp.	Northridge, Cal.
03508	G. E. Semiconductor Prod. Dept.	Syracuse, N. Y.	08145	U. S. Engineering Co.	Los Angeles, Cal.	15291	Adjustable Bushing Co.	N. Hollywood, Cal.
03705	Apex Machine & Tool Co.	Dayton, Ohio	08289	Blinn, Delbert Co.	Pomona, Cal.	15558	Micron Electronics, Garden City	Long Island, N. Y.
03797	Eldema Corp.	Compton, Calif.	08358	Burgess Battery Co.	Niagara Falls, Ontario, Canada	15566	Amprobe Inst. Corp.	Lynbrook, N. Y.
03818	Parker Seal Co.	Los Angeles, Cal.	08524	Deutsch Fastener Corp.	Los Angeles, Cal.	15631	Cabletronics	Costa Mesa, Cal.
03877	Transitron Electric Corp.	Wakefield, Mass.	08664	Bristol Co., The	Waterbury, Conn.	15772	Twentieth Century Coil Spring Co.	Santa Clara, Cal.
03888	Pyrofilm Resistor Co., Inc.	Cedar Knolls, N. J.	08717	Sloan Company	Sun Valley, Cal.	15801	Fenwal Elect. Inc.	Framingham, Mass.
03954	Singer Co., Diehl Div., FINDERNE Plant	Sumerville, N. J.	08718	ITT Cannon Electric Inc., Phoenix Div.	Phoenix, Arizona	15818	Amelco Inc.	Mountain View, Cal.
04009	Arrow, Hart and Hegeman Elect. Co.	Hartford, Conn.	08727	National Radio Lab. Inc.	Paramus, N. J.	16037	Spruce Pine Mica Co.	Spruce Pine, N. C.
04013	Taruus Corp.	Lambertville, N. J.	08792	CBS Electronics Semiconductor Operations, Div. of CBS Inc.	Lowell, Mass.	16179	Omni-Spectra Inc.	Detroit, Ill.
04062	Arco Electronic Inc.	Great Neck, N. Y.	08806	General Electric Co., Miniature Lamp Dept.	Cleveland, Ohio	16352	Computer Diode Corp.	Lodi, N. J.
04217	Essex Wire	Los Angeles, Cal.	08984	Mel-Rain	Indianapolis, Ind.	16554	Electroid Co.	Union, N. J.
04222	Hi-Q Division of Aerovox	Myrtle Beach, S. C.	09026	Babeock Relays Div.	Costa Mesa, Cal.	16585	Boots Aircraft Nut Corp.	Pasadena, Cal.
04354	Precision Paper Tube Co.	Wheeling, Ill.	09097	Electronic Enclosures Inc.	Los Angeles, Calif.	16688	Ideal Prec. Meter Co., Inc., De Jur Meter Div.	Brooklyn, N. Y.
04404	Palo Alto Division of Hewlett-Packard Co.	Palo Alto, Cal.	09134	Texas Capacitor Co.	Houston, Texas	16758	Delco Radio Div. of G. M. Corp.	Kokomo, Ind.
04651	Sylvania Electric Products, Microwave Device Div.	Mountain View, Cal.	09145	Tech. Ind. Inc. Atohm Elect.	Burbank, Cal.	17109	Thermonetics Inc.	Canoga Park, Cal.
04673	Dakota Engr. Inc.	Culver City, Cal.	09250	Electro Assemblies, Inc.	Chicago, Ill.	17474	Tranex Company	Mountain View, Cal.
04713	Motorola Inc. Semiconductor Prod. Div.	Phoenix, Arizona	09353	C & K Components Inc.	Newton, Mass.	17675	Hamlin Metal Products Corp.	Akron, Ohio
04732	Filtron Co., Inc. Western Div.	Culver City, Cal.	09569	Mallory Battery Co. of Canada, Ltd.	Toronto, Ontario, Canada	17745	Angstromh Prec. Inc.	No. Hollywood, Cal.
04773	Automatic Electric Co.	Northlake, Ill.	09795	Pennsylvania Florocarbon	Clifton Heights, Penn.	17856	Siliconix Inc.	Sunnyvale, Cal.
04796	Sequoia Wire Co.	Redwood City, Cal.	09922	Burdny Corp.	Norwalk, Conn.	17870	McGraw-Edison Co.	Manchester, N. H.
04811	Precision Coil Spring Co.	El Monte, Cal.	10214	General Transistor Western Corp.	Los Angeles, Cal.	18042	Power Design Pacific Inc.	Palo Alto, Cal.
04870	P. M. Motor Company	Westchester, Ill.	10411	Ti-Tal, Inc.	Berkeley, Cal.	18083	Clevite Corp. Semiconductor Div.	Palo Alto, Cal.
04919	Component Mfg. Service Co.	W. Bridgewater, Mass.	10646	Carborundum Co.	Niagara Falls, N. Y.	18324	Signetics Corp.	Sunnyvale, Cal.
05006	Twentieth Century Plastics, Inc.	Los Angeles, Cal.				18476	Ty-Car Mfg. Co., Inc.	Holliston, Mass.
05277	Westinghouse Electric Corp. Semiconductor Dept.	Youngwood, Pa.				18486	TRW Elect. Comp. Div.	Des Plaines, Ill.

CODE LIST OF MANUFACTURERS (Continued)

Code No.	Manufacturer	Address	Code No.	Manufacturer	Address	Code No.	Manufacturer	Address
19644	LRC Electronics	Horseheads, N. Y.	71482	C. P. Clare & Co.	Chicago, Ill.	78452	Thompson-Bremer & Co.	Chicago, Ill.
19701	Electra Mfg. Co.	Independence, Kansas	71590	Centralab Div. of		78471	Tilley Mfg. Co.	San Francisco, Cal.
20183	General Atomics Corp.	Philadelphia, Pa.		Globe Union Inc.	Milwaukee, Wis.	78488	Stackpole Carbon Co.	St. Marys, Pa.
21226	Executone, Inc.	Long Island City, N. Y.	71616	Commercial Plastics Co.	Chicago, Ill.	78493	Standard Thomson Corp.	Waltham, Mass.
21355	Fafnir Bearing Co., The	New Britain, Conn.	71700	Cornish Wire Co., The	New York, N. Y.	78553	Tinnerman Products, Inc.	Cleveland, Ohio
21520	Fansteel Metallurgical Corp.	N. Chicago, Ill.	71707	Coto Coil Co., Inc.	Providence, R. I.	78790	Transformer Engineers	San Gabriel, Cal.
23020	General Reed Co.	Metuchen, N. J.	71744	Chicago Miniature Lamp Works	Chicago, Ill.	78947	Ucinite Co.	Newtonville, Mass.
23042	Texscan Corp.	Indianapolis, Ind.	71785	Cinch Mfg. Co.		79136	Valdes Kohinoor Inc.	Long Island City, N. Y.
23783	British Radio Electronics Ltd.	Washington, D.C.		Howard B. Jones Div.	Chicago, Ill.	79142	Welder Root, Inc.	Hartford, Conn.
24455	G. E. Lamp Division	Nela Park, Cleveland, Ohio	71984	Dow Corning Corp.	Midland, Mich.	79251	Wenco Mfg. Co.	Chicago, Ill.
24655	General Radio Co.	West Concord, Mass.	72136	Electro Motive Mfg. Co., Inc.		79727	Continental-Wirt Electronics Corp.	
24681	Memcor Inc., Comp. Div.	Huntington, Ind.			Willimantic, Conn.			Philadelphia, Pa.
26365	Gries Reproducer Corp.	New Rochelle, N. Y.	72619	Dialight Corp.	Brooklyn, N. Y.	79963	Zierick Mfg. Corp.	New Rochelle, N. Y.
26462	Grobert File Co. of America, Inc.	Carlstadt, N. J.	72656	Indiana General Corp.,		80031	Bepec Division of Sessions Clock Co.	
26851	Compac/Hollister Co.	Hollister, Cal.		Electronics Div.	Keasby, N. J.			Morristown, N. J.
26992	Hamilton Watch Co.	Lancaster, Pa.	72699	General Instrument Corp.,		80033	Prestole Corp.	Toledo, Ohio
28480	Hewlett-Packard Co.	Palo Alto, Cal.		Cap Division	Newark, N. J.	80120	Schnitzer Alloy Products Co.	Elizabeth, N. J.
28520	Heyman Mfg. Co.	Kenilworth, N. J.	72765	Drake Mfg. Co.	Harwood Heights, Ill.	80131	Electronic Industries Association.	
30817	Instrument Specialties Co.,		72825	Hugh H. Eby Inc.	Philadelphia, Pa.		Standard tube or semi-conductor device,	
	Inc.	Little Falls, N. J.	72928	Gudeman Co.	Chicago, Ill.		any manufacturer.	
33173	G. E. Receiving Tube Dept.	Owensboro, Ky.	72962	Elastic Stop Nut Corp.	Union, N. J.	80207	Unimax Switch, Div. Maxon Electronics	
35434	Lectrohm Inc.	Chicago, Ill.	72964	Robert M. Hadley Co.	Los Angeles, Cal.		Corp.	Wallingford, Conn.
36196	Stanwyck Coil Products,		72982	Eric Technological Products, Inc.	Erie, Pa.	80223	United Transformer Corp.	New York, N. Y.
	Ltd.	Hawkesbury, Ontario, Canada	73061	Hansen Mfg. Co., Inc.	Princeton, Ind.	80248	Oxford Electric Corp.	Chicago, Ill.
36287	Cunningham, W. H. & Hill,		73076	H. M. Harper Co.	Chicago, Ill.	80294	Bourns Inc.	Riverside, Cal.
	Ltd.	Toronto, Ontario, Canada	73138	Heiprot Div. of Beckman Inst., Inc.		80411	Arco Div. of Robertshaw Controls Co.	
37942	P. R. Mallory & Co., Inc.	Indianapolis, Ind.			Fullerton, Cal.			Columbus, Ohio
39543	Mechanical Industries Prod. Co.	Akron, Ohio	73293	Hughes Products Division of		80486	All Star Products Inc.	Defiance, Ohio
40920	Miniature Precision Bearings, Inc.	Keene, N. H.		Hughes Aircraft Co.	Newport Beach, Cal.	80509	Avery Label Co.	Monrovia, Cal.
40931	Honeywell Inc.	Minneapolis, Minn.	73445	Amperex Elect. Co.	Hicksville, L. I., N. Y.	80583	Hammarlund Co., Inc.	Mars Hill, N. C.
42190	Muter Co.	Chicago, Ill.	73506	Bradley Semiconductor Corp.		80640	Stevens, Arnold, Co., Inc.	Boston, Mass.
43990	C. A. Norgren Co.	Englewood, Colo.			New Haven, Conn.	80813	Dimco Gray Co.	Dayton, Ohio
44655	Ohmite Mfg. Co.	Skokie, Ill.	73559	Carling Electric, Inc.	Hartford, Conn.	81030	International Inst. Inc.	Orange, Conn.
46384	Penn Eng. & Mfg. Corp.	Doylestown, Pa.	73586	Circle F Mfg. Co.	Trenton, N. J.	81073	Grayhill Co.	LaGrange, Ill.
47904	Polaroid Corp.	Cambridge, Mass.	73682	George K. Garrett Co.,		81095	Triad Transformer Corp.	Venice, Cal.
48620	Precision Thermometer &			Div. MSL Industries, Inc.	Philadelphia, Pa.	81312	Winchester Elec. Div. Litton Ind., Inc.	
	Inst. Co.	Southampton, Pa.	73734	Federal Screw Products, Inc.	Chicago, Ill.			Oakville, Conn.
49956	Microwave & Power Tube Div.	Waltham, Mass.	73743	Fischer Special Mfg. Co.	Cincinnati, Ohio	81349	Military Specification	
52090	Rowan Controller Co.	Westminster, Md.	73793	General Industries Co., The	Elyria, Ohio	81483	International Rectifier Corp.	El Segundo, Cal.
52983	HP Co., Med. Elec. Div.	Waltham, Mass.	73846	Goshen Stamping & Tool Co.	Goshen, Ind.	81541	Airpax Electronics, Inc.	Cambridge, Maryland
54294	Shallcross Mfg. Co.	Selma, N. C.	73899	JFD Electronics Corp.	Brooklyn, N. Y.	81860	Barry Controls, Div. Barry Wright Corp.	
55026	Simpson Electric Co.	Chicago, Ill.	73905	Jennings Radio Mfg. Corp.	San Jose, Cal.			Watertown, Mass.
55933	Sonotone Corp.	Elmsford, N. Y.	73957	Groove-Pin Corp.	Ridgefield, N. J.	82042	Carter Precision Electric Co.	Skokie, Ill.
55938	Raytheon Co. Commercial Apparatus		74276	Signalite Inc.	Neptune, N. J.	82047	Sperit Faraday Inc.	Copper Hewitt
	& System Div.	So. Norwalk, Conn.	74455	J. H. Winns, and Sons	Winchester, Mass.		Electric Div.	Hoboken, N. J.
56137	Spauding Fibre Co., Inc.	Tonawanda, N. Y.	74861	Industrial Condenser Corp.	Chicago, Ill.	82116	Electric Regulator Corp.	Norwalk, Conn.
56289	Sprague Electric Co.	North Adams, Mass.	74868	R. F. Products Division of		82142	Jeffers Electronics Division of	
58474	Superior Elect. Co.	Bristol, Conn.		Amphenol-Borg Electronic Corp.			Speer Carbon Co.	Du Bois, Pa.
59446	Telex Corp.	Tulsa, Okla.			Danbury, Conn.	82170	Fairchild Camera & Inst. Corp.,	
59730	Thomas & Betts Co.	Elizabeth, N. J.	74970	E. F. Johnson Co.	Waseca, Minn.		Space & Defense Systems Div.	Paramus, N. J.
60741	Triplet Electrical Inst. Co.	Bluffton, Ohio	75042	International Resistance Co.	Philadelphia, Pa.	82209	Magurie Industries, Inc.	Greenwich, Conn.
61775	Union Switch and Signal Div. of		75263	Keystone Carbon Co., Inc.	St. Marys, Pa.	82219	Sylvania Electric Prod., Inc.	
	Westinghouse Air Brake Co.	Pittsburgh, Pa.	75378	CTS Knights, Inc.	Sandwich, Ill.		Electronic Tube Division	Emporium, Pa.
62119	Universal Electric Co.	Owosso, Mich.	75382	Kulka Electric Corp.	Mt. Vernon, N. Y.	82376	Astron Corp.	East Newark, Harrison, N. J.
63743	Ward-Leonard Electric Co.	Mt. Vernon, N. Y.	75818	Lenz Electric Mfg. Co.	Chicago, Ill.	82389	Switchcraft, Inc.	Chicago, Ill.
64959	Western Electric Co., Inc.	New York, N. Y.	75915	Littlefuse, Inc.	Des Plaines, Ill.	82647	Metals & Controls Inc.,	
65092	Weston Inst. Inc.	Weston-Newark, Newark, N. J.	76005	Lord Mfg. Co.	Erie, Pa.		Spencer Products	Attleboro, Mass.
66295	Witteck Mfg. Co.	Chicago, Ill.	76210	C. W. Marwedel	San Francisco, Cal.	82768	Phillips-Advance Control Co.	Joliet, Ill.
66346	Minnesota Mining & Mfg. Co.		76433	General Instrument Corp.,		82866	Research Products Corp.	Madison, Wis.
	Revere Mincom Div.	St. Paul, Minn.		Micamold Division	Newark, N. J.	82877	Rolton Mfg. Co., Inc.	Woodstock, N. Y.
70276	Allen Mfg. Co.	Hartford, Conn.	76487	James Millen Mfg. Co., Inc.	Malden, Mass.	82893	Vector Electronic Co.	Glendale, Cal.
70309	Allied Control	New York, N. Y.	76493	J. W. Miller Co.	Los Angeles, Cal.	83058	Carr Fastener Co.	Cambridge, Mass.
70318	Allmetal Screw Product Co., Inc.		76530	Cinch-Monadnock, Div. of United Carr		83086	New Hampshire Ball	
		Garden City, N. Y.		Fastener Corp.	San Leandro, Cal.		Bearing, Inc.	Peterborough, N. H.
70417	Amplex, Div. of Chrysler Corp.	Detroit, Mich.	76545	Mueller Electric Co.	Cleveland, Ohio	83125	General Instrument Corp.,	
70485	Atlantic India Rubber Works, Inc.	Chicago, Ill.	76703	National Union	Newark, N. J.		Capacitor Div.	Darlington, S. C.
70563	Amperite Co., Inc.	Union City, N. J.	76854	Oak Manufacturing Co.	Crystal Lake, Ill.	83148	ITT Wire and Cable Div.	Los Angeles, Cal.
70674	ADC Products Inc.	Minneapolis, Minn.	77068	The Bendix Corp.,		83186	Victory Eng. Corp.	Springfield, N. J.
70903	Belden Mfg. Co.	Chicago, Ill.		Electrodynamics Div.	N. Hollywood, Cal.	83298	Bendix Corp., Red Bank Div.	Red Bank, N. J.
70998	Bird Electric Corp.	Cleveland, Ohio	77075	Pacific Metals Co.	San Francisco, Cal.	83315	Hubbell Corp.	Mundelein, Ill.
71002	Birnbach Radio Co.	New York, N. Y.	77221	Phaostran Instrument and		83324	Rosan Inc.	Newport Beach, Cal.
71034	Bliley Electric Co., Inc.	Erie, Pa.		Electronic Co.	So. Pasadena, Cal.	83330	Smith, Herman H., Inc.	Brooklyn, N. Y.
71041	Boston Gear Works Div. of		77252	Philadelphia Steel and		83332	Tech Labs	Palisades Park, N. Y.
	Murray Co. of Texas	Quincey, Mass.		Wire Corp.	Philadelphia, Pa.	83385	Central Screw Co.	Chicago, Ill.
71218	Bud Radio, Inc.	Willoughby, Ohio	77342	American Machine & Foundry Co.		83501	Gavitt Wire and Cable Co., Div. of	
71279	Cambridge Thermionics Corp.	Cambridge, Mass.		Potter & Brumfield Div.	Princeton, Ind.		Amerace Corp.	Brookfield, Mass.
71286	Camloc Fastener Corp.	Paramus, N. J.	77630	TRW Electronic Components Div.	Camden, N. J.	83594	Burrughs Corp., Electronic	
71313	Cardwell Condenser Corp.		77638	General Instrument Corp.,			Tube Div.	Plainfield, N. J.
		Lindenhurst, L. I., N. Y.		Rectifier Division	Brooklyn, N. Y.	83740	Union Carbide Corp., Consumer	
71400	Bussmann Mfg. Div. of		77764	Resistance Products Co.	Harrisburg, Pa.		Prod. Div.	New York, N. Y.
	McGraw-Edison Co.	St. Louis, Mo.	77969	Rubbercraft Corp. of Calif.	Torrance, Cal.	83777	Model Eng. and Mfg., Inc.	Huntington, Ind.
71436	Chicago Condenser Corp.	Chicago, Ill.	78189	Shakeproof Division of		83821	Loyd Scruggs Co.	Festus, Mo.
71447	Calif. Spring Co., Inc.	Pico-Rivera, Cal.		Illinois Tool Works	Elgin, Ill.	83942	Aeronautical Inst. & Radio Co.	Lodi, N. J.
71450	CTS Corp.	Elkhart, Ind.	78277	Sigma	So. Braintree, Mass.	84171	Arco Electronics Inc.	Great Neck, N. Y.
71468	ITT Cannon Electric Inc.	Los Angeles, Cal.	78283	Signal Indicator Corp.	New York, N. Y.	84396	A. J. Glesener Co., Inc.	San Francisco, Cal.
71471	Cinema, Div. Aerovox Corp.	Burbank, Cal.	78290	Struthers-Dunn Inc.	Pitman, N. J.	84411	TRW Capacitor Div.	Ogallala, Neb.

00015-49
Revised: May, 1970

From: Handbook Supplements
H4-1 Dated January 1970

CODE LIST OF MANUFACTURERS (Continued)

Code No.	Manufacturer	Address	Code No.	Manufacturer	Address	Code No.	Manufacturer	Address
94870	Sarkes Tarzian, Inc.	Bloomington, Ind.	91929	Honeywell Inc., Micro Switch Division	Freeport, Ill.	96095	Hi-Q Div. of Aerovox Corp.	Olean, N. Y.
85454	Boonton Molding Company	Boonton, N.J.	91961	Nahm-Bros. Spring Co.	Oakland, Cal.	96256	Thordarson-Meissner Inc.	Mt. Carmel, Ill.
85471	A. B. Boyd Co.	San Francisco, Cal.	92180	Tru-Connector Corp.	Peabody, Mass.	96296	Solar Mfg. Co.	Los Angeles, Cal.
85474	R. M. Bracamonte & Co.	San Francisco, Cal.	92367	Elgeet Optical Co., Inc.	Rochester, N. Y.	96396	Microswitch, Div. of	
85660	Koiled Kords, Inc.	Hamden, Conn.	92607	Tensolite Insulated Wire Co., Inc.	Tarrytown, N. Y.		Minn.-Honeywell	Freeport, Ill.
85911	Seamless Rubber Co.	Chicago, Ill.	92702	IMC Magnetics Corp.	Westbury, L. I., N. Y.	96330	Carlton Screw Co.	Chicago, Ill.
86174	Fafnir Bearing Co.	Los Angeles, Calif.	92966	Hudson Lamp Co.	Kearney, N. J.	96341	Microwave Associates, Inc.	Burlington, Mass.
86197	Clifton Precision Products Co., Inc.	Clifton Heights, Pa.	93332	Sylvania Electric Prod. Inc., Semiconductor Div.	Woburn, Mass.	96501	Excel Transformer Co.	Oakland, Cal.
86579	Precision Rubber Products Corp.	Dayton, Ohio	93369	Robbins & Myers Inc.	Pallisades Park, N. J.	96508	Xcelite, Inc.	Orchard Park, N. Y.
86684	Radio Corp. of America, Electronic Comp. & Devices Division	Harrison, N. J.	93410	Stemco Controls, Div. of Essex Wire Corp.	Mansfield, Ohio	96733	San Fernando Elec. Mfg. Co.	San Fernando, Cal.
86928	Seastrom Mfg. Co.	Glendale, Cal.	93632	Waters Mfg. Co.	Culver City, Cal.	96881	Thomson Ind. Inc.	Long Island, N. Y.
87034	Marco Industries	Anaheim, Cal.	93929	G. V. Controls	Livingston, N. J.	97464	Industrial Retaining Ring Co.	Irvington, N. J.
87216	Philco Corporation (Lansdale Division)	Lansdale, Pa.	94137	General Cable Corp.	Bayonne, N. J.	97539	Automatic & Precision Mfg.	Englewood, N. J.
87473	Western Fibrous Glass Products Co.	San Francisco, Cal.	94144	Raytheon Co., Comp. Div., Ind. Comp. Operations	Quincy, Mass.	97979	Remon Resistor Corp.	Yonkers, N. Y.
87664	Van Waters & Rogers Inc.	San Francisco, Cal.	94148	Scientific Electronics Products, Inc.	Loveland, Colo.	97983	Litton System Inc., Adler-Westrex Commun. Div.	New Rochelle, N. Y.
87930	Tower Mfg. Corp.	Providence, R. I.	94154	Wagner Elect. Corp., Tung-Sol Div.	Newark, N. J.	98141	R-Tronics, Inc.	Jamaica, N. Y.
88140	Cutler-Hammer, Inc.	Lincoln, Ill.	94197	Curtiss-Wright Corp., Electronics Div.	East Patterson, N. J.	98159	Rubber Teck, Inc.	Gardena, Cal.
88220	Gould-National Batteries, Inc.	St. Paul, Minn.	94222	South Chester Corp.	Chester, Pa.	98220	Hewlett-Packard Co., Medical Elec. Div.	Pasadena, Cal.
88698	General Mills, Inc.	Buffalo, N. Y.	94330	Wire Cloth Products, Inc.	Bellwood, Ill.	98278	Microdot, Inc.	So. Pasadena, Cal.
89231	Graybar Electric Co.	Oakland, Cal.	94375	Automatic Metal Products Co.	Brooklyn, N. Y.	98291	Sealectro Corp.	Mamaronech, N. Y.
89473	G. E. Distributing Corp.	Schenectady, N. Y.	94682	Worcester Pressed Aluminum Corp.	Worcester, Mass.	98376	Zero Mfg. Co.	Burbank, Cal.
89479	Security Co.	Detroit, Mich.	94696	Magnecraft Electric Co.	Chicago, Ill.	98410	Etc. Inc.	Cleveland, Ohio
89665	United Transformer Co.	Chicago, Ill.	95023	George A. Philbrick Researchers, Inc.	Boston, Mass.	98731	General Mills Inc., Electronics Div.	Minneapolis, Minn.
90030	United Shoe Machinery Corp.	Beverly, Mass.	95146	Alco Elect. Mfg. Co.	Lawrence, Mass.	98734	Paeco Division of Hewlett-Packard Co.	Palo Alto, Cal.
90179	U. S. Rubber Co., Consumer Ind. & Plastics Prod. Div.	Passaic, N. J.	95236	Allies Products Corp.	Dania, Fla.	98821	North Hills Electronics, Inc.	Glen Cove, N. Y.
90365	Belleville Speciality Tool Mfg., Inc.	Belleville, Ill.	95238	Continental Connector Corp.	Woodside, N. Y.	98978	International Electronic Research Corp.	Burbank, Cal.
90763	United Carr Fastener Corp.	Chicago, Ill.	95263	Leecraft Mfg. Co., Inc.	Long Island, N. Y.	99109	Columbia Technical Corp.	New York, N. Y.
90970	Bearing Engineering Co.	San Francisco, Cal.	95265	National Coil Co.	Sheridan, Wyo.	99313	Varian Associates	Palo Alto, Cal.
91146	ITT Cannon Elect. Inc., Salem Div.	Salem, Mass.	95275	Vitramon, Inc.	Bridgeport, Conn.	99378	Atlec Corp.	Winchester, Mass.
91260	Connor Spring Mfg. Co.	San Francisco, Cal.	95348	Gordos Corp.	Bloomfield, N. J.	99515	Marshall Ind., Capacitor Div.	Monrovia, Cal.
91345	Miller Dial & Nameplate Co.	El Monte, Cal.	95354	Methode Mfg. Co.	Rolling Meadows, Ill.	99707	Control Switch Division, Controls Co. of America	El Segundo, Cal.
91418	Radio Materials Co.	Chicago, Ill.	95566	Arnold Engineering Co.	Marengo, Ill.	99800	Delevan Electronics Corp.	East Aurora, N. Y.
91506	Augat Inc.	Attleboro, Mass.	95712	Dage Electric Co., Inc.	Franklin, Ind.	99848	Wilco Corporation	Indianapolis, Ind.
91637	Dale Electronics, Inc.	Columbus, Nebr.	95984	Siemon Mfg. Co.	Wayne, Ill.	99928	Branson Corp.	Whippany, N. J.
91662	Elco Corp.	Willow Grove, Pa.	95987	Weckesser Co.	Chicago, Ill.	99934	Rembrandt, Inc.	Boston, Mass.
91673	Epiphone Inc.	New York, N. Y.	96067	Microwave Assoc., West, Inc.	Sunnyvale, Cal.	99942	Hoffman Electronics Corp., Semiconductor Division	El Monte, Cal.
91737	Gremer Mfg. Co., Inc.	Wakefield, Mass.				99957	Technology-Instrument Corp. of California	Newbury Park, Cal.
91827	K F Development Co.	Redwood City, Cal.						
91886	Malco Mfg., Inc.	Chicago, Ill.						

The following HP Vendors have no number assigned in the latest supplement to the Federal Supply Code for Manufacturers Handbook.

0000F	Malco Tool and Die	Los Angeles, Calif.	000CS	Hewlett-Packard Co., Colorado Springs Div.	Colorado Springs, Colorado	000QQ	Cooltron	Oakland, Cal.
0000Z	Willow Leather Products Corp.	Newark, N. J.	000MM	Rubber Eng. & Development	Hayward, Cal.	000WW	California Eastern Lab	Burlington, Cal.
000AB	ETA	England	000NN	A "N" D Mfg. Co.	San Jose, Cal.	000YY	S. K. Smith Co.	Los Angeles, Cal.
000BB	Precision Instrument Comp. Co.	Van Nuys, Cal.						

