

# INSTRUCTION MANUAL

Serial Number \_\_\_\_\_

**TYPE  
141A/R141A  
PAL TELEVISION  
TEST SIGNAL  
GENERATOR**

*Tektronix, Inc.*

S.W. Millikan Way ● P. O. Box 500 ● Beaverton, Oregon 97005 ● Phone 644-0161 ● Cables: Tektronix  
070-1008-00



## WARRANTY

All Tektronix instruments are warranted against defective materials and workmanship for one year.

Any questions with respect to the warranty mentioned above should be taken up with your Tektronix Field Engineer.

Tektronix repair and replacement-part service is geared directly to the field, therefore all requests for repairs and replacement parts should be directed to the Tektronix Field Office or representative in your area. This procedure will assure you the fastest possible service. Please include the instrument Type and Serial or Model Number with all requests for parts or service.

Specifications and price change privileges reserved.

Copyright © 1969 by Tektronix, Inc., Beaverton, Oregon. Printed in the United States of America. All rights reserved. Contents of this publication may not be reproduced in any form without permission of the copyright owner.



# CONTENTS

- Section 1 Specification
- Section 2 Operating Instructions
- Section 3 Circuit Description
- Section 4 Maintenance
- Section 5 Performance Check/Calibration

Abbreviations and Symbols

Parts Ordering Information

- Section 6 Electrical Parts List

Mechanical Parts List Information

- Section 7 Mechanical Parts List

- Section 8 Diagrams

Mechanical Parts List Illustrations

Accessories

- Section 9 Rackmounting

- Section 10 Field Blanking Details

Abbreviations and symbols used in this manual are based on or taken directly from IEEE Standard 260 "Standard Symbols for Units", MIL-STD-12B and other standards of the electronics industry. Change information, if any, is located at the rear of this manual.

SEE PARTS LIST FOR  
SEMICONDUCTOR TYPES

SEE REAR PANEL FOR  
FIELD BLANKING DETAILS

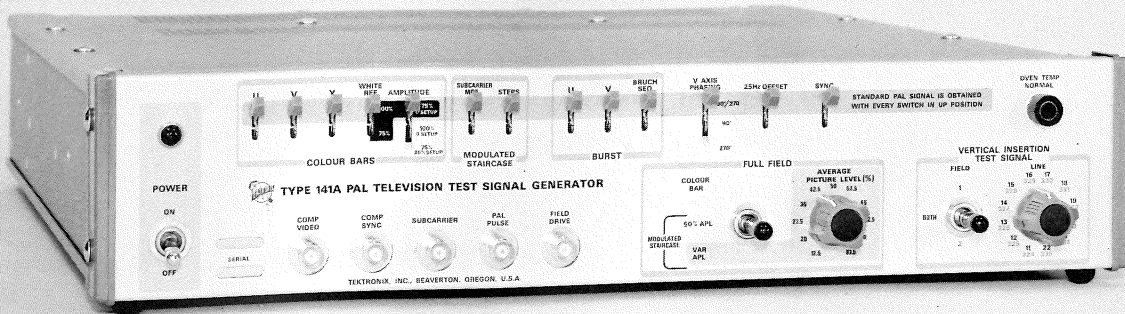

(A) The Type 141A PAL Television Test Signal Generator (cabinet model for portable use).

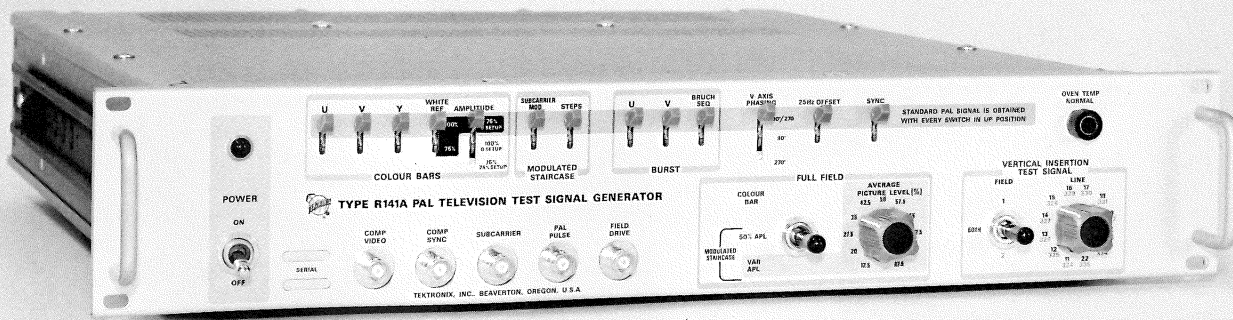

(B) The Type R141A PAL Television Test Signal Generator (rackmount model).

Fig. 1-1. The two models of the generator are electrically identical.

# SECTION 1

## TYPE 141A/R141A SPECIFICATION

Change information, if any, affecting this section will be found at the rear of the manual.

### General Information

The Tektronix Types 141A and R141A PAL Television Test Signal Generators<sup>1</sup> are a source of high-quality television test signals for 625-line, 50-cycle field standard PAL<sup>2</sup> colour TV Systems. The all solid state Type R141A utilizes digital integrated circuits to achieve compactness, stability, accuracy, and reliability. Three operating modes provide PAL colour bars, 5-step staircase with fixed Average Picture Level (APL), and 5-step staircase with variable APL.

The standard colour bar output is a full-field test signal appearing on every active line, and consists of 75% amplitude colour bars in descending luminance order without setup. The white reference can be selected for 75% or 100%. With 100% white reference, the signal is known as EBU bars (European Broadcast Union). To meet the needs and preferences of TV engineers in the United Kingdom and on the Continent, two other versions of colour bar signal can be selected: 100% amplitude bars with 100% white reference and no setup, and 75% amplitude bars with 100% white reference and 25% setup. The latter signal is referred to in the United Kingdom as 95% bars.

The staircase signal is particularly useful with a Tektronix Type 520 PAL Vectroscope to measure differential phase and differential gain (the transient response of the staircase signal component is determined by a  $\sin^2$  filter whose cutoff frequency limits the energy content in the region of the colour subcarrier frequency). Luminance channel linearity may also be measured with an oscilloscope and a Tektronix Video Staircase Differentiator (Part No. 015-0075-00), or a Tektronix Type 529 MOD 188D.

The PAL subcarrier component of the staircase signal is 140 mV peak to peak in amplitude and is accurately phased at 180°. Thus, the subcarrier vector lies along the —U PAL axis on all lines carrying the staircase signal. If desired, the subcarrier may be switched off. The last step (at white level) is double width so it can be viewed with and without subcarrier to detect clipping in the white direction. To provide VITS (Vertical Insertion Test Signal) information, the staircase signal is keyed on during a selected line of the vertical blanking interval in one or both pairs of fields, depending on the settings of the FIELD and LINE switches.

Normal PAL colour burst is provided on the staircase and colour bar signals. The complex four-field Bruch blanking sequence during the vertical interval is provided and may be switched off.

<sup>1</sup>Since both models of the generator are electrically identical, the rackmount model (Type R141A) is used for the text and illustrations in this manual unless noted otherwise.

<sup>2</sup>Phase Alternation Line system.

<sup>3</sup>Gen-lock: to link or synchronize one system to another with regard to frequency and phase.

A 1-MHz reference signal which is frequency "locked" to the 4.43361875 MHz PAL subcarrier oscillator is made available at the back of the instrument. The accuracy of the internal subcarrier oscillator may be conveniently verified by comparing the 1-MHz reference with known frequencies, such as the Droitwich 200-kHz radio transmissions in Europe. Subcarrier frequency stability and other specifications conform with present CCIR practice.

Outputs provided on the front and rear of the instrument are Comp Video, Comp Sync, Subcarrier, PAL Pulse, and Field Drive. Additional outputs provided at the rear of this instrument are Comp Blanking, Line Drive, Burst Flag, and reference signals of 12.5 Hz, 25 Hz, and 1.00 MHz. The Type R141A can serve as a PAL Sync Generator. However, it may not be gen-locked<sup>3</sup> to another PAL video signal.

### ELECTRICAL CHARACTERISTICS

The following performance requirements apply over an ambient temperature range of 0°C to +50°C. The rated accuracies are valid when the instrument is calibrated at +20°C to +30°C, after a warm-up time of 5 minutes. A 20-minute warm-up is required for rated accuracies at 0°C ambient temperature.

TABLE 1-1

STAIRCASE SIGNAL ELECTRICAL CHARACTERISTICS

Characteristic	Performance Requirement
Staircase Signal	The staircase signal is similar to that in volume 5 of CCIR, recommendations 421-1 and 451, but differs in that a white reference signal is provided and the subcarrier is phased to the —U axis.
Luminance Component	
Step Amplitude	140 mV within 1%.
5 Step Amplitude	700 mV within 1%.
Step Risetime	260 ns within 15%.
Aberrations	Within 2%.
Step Duration	
Blanking Level	13 $\mu$ s within 5%.
White Level	13 $\mu$ s within 5%.
Intermediate Level	6.5 $\mu$ s within 5%.
Chrominance Component	
Amplitude	140 mV peak to peak within 3%.
Phase	180°

**Specification—Type 141A/R141A**

Differential Phase	
12.5% APL	0.1° or less.
50% APL	0.1° or less.
87.5% APL	0.1° or less.
Differential Gain	
12.5% APL	0.5% or less.
50% APL	0.5% or less.
87.5% APL	0.5% or less.
VAR APL	Staircase signal on every fourth line and the same line each frame.
Luminance Level Range	0 V to 700 mV in 10 equal increments within 2%.
Luminance Level Subcarrier Modulation Phase	On the 90°/270° axis.
Amplitude	30 mV within 20%.
Subcarrier Envelope Risetime	260 ns within 15%.
Duration	39 μs within 5%.

**TABLE 1-2**

**COLOUR BAR ELECTRICAL CHARACTERISTICS**

Characteristic	Performance Requirement
Luminance and Chrominance	Absolute amplitudes of luminance signal, setup and sync are within 1% or 1.5 mV, whichever is greater.
	Absolute amplitudes of all subcarrier frequency components (Chrominance, U, V) are within 3%.
	Relative amplitudes of all subcarrier frequency components are within 1% or 1.5 mV, whichever is greater, of the red chrominance bar.

**75% Amplitude, 100% Saturation, 0% Setup or Pedestal.**

Component	Luminance (mV)	Chrominance (mV)	U (mV)	V (mV)
Peak White (41% APL)	700.0	≤2.5		
White (37.5% APL)	525.0	≤2.5		
Yellow	465.2	470.5	458.6	105.0
Cyan	368.0	663.8	154.8	645.5
Green	308.2	620.1	303.8	540.5
Magenta	216.8	620.1	303.8	540.5
Red	157.0	663.8	154.8	645.5
Blue	59.8	470.5	458.6	105.0
Black, Blanking	0	≤2.5		
Sync	-300.0	≤2.5		

**100% Amplitude, 100% Saturation, 0% Setup or Pedestal. White reference fixed at 100%.**

White (50% APL)	700.0	≤2.5		
Yellow	620.2	627.3	611.5	140.0
Cyan	490.7	885.1	206.4	860.7
Green	410.9	826.8	405.1	720.7
Magenta	289.1	826.8	405.1	720.7
Red	209.3	885.1	206.4	860.7
Blue	79.8	627.3	611.5	140.0
Black, Blanking	0	≤2.5		

**75% Amplitude, 100% Saturation, 25% Setup or Pedestal. White reference fixed at 100%.**

White (59% APL)	700.0	≤2.5		
Yellow	640.2	470.5	458.6	105.0
Cyan	543.0	663.8	154.8	645.5
Green	483.2	620.1	303.8	540.5
Magenta	391.8	620.1	303.8	540.5
Red	332.0	663.8	154.8	645.5
Blue	234.8	470.5	458.6	105.0
Black, Blanking	0	≤2.5		

Blanking to White	700 mV within 1.5%.
Bar Width	6.5 μs within 5%.
Risetime (White Bar)	100 ns within 10%.
White Reference	100% amplitude, normal; or 75% amplitude.
Chrominance	
Time difference between Luminance and Chrominance channels.	20 ns or less.
Risetime	260 ns within 10%.
U and V Quadrature Error	0.5° or less.
V Axis Phase Switcher	0.5° or less.
Residual Subcarrier	At least 52 dB below 1 volt on White, Black.
Aberrations	4% peak to peak of 1 volt.
Spurious Subcarrier	At least 52 dB below 1 volt when viewed on a Type 529 Waveform Monitor, except 30 dB at the end of H blanking.
Other Spurious Outputs	At least 52 dB below 1 volt when viewed on a Type 529 waveform monitor, except 30 dB during sync and at the end of H Blanking.
COMP VIDEO	
Return Loss	At least 30 dB.
Isolation	At least 40 dB.
Front Porch	1.8 μs within 5%

**TABLE 1-3**

**SYNC ELECTRICAL CHARACTERISTICS**

Characteristic	Performance Requirement
SUBCARRIER	4.43361875 MHz within 5 Hz. Within 1 Hz per 2 week period drift.
Impedance	75 ohms within 5%.



Isolation	At least 30 dB.
Output Level	2 volts peak to peak within 0.2 volt into 75 ohms.
<b>COMP SYNC</b>	
Output Level	4 volts peak to peak within 0.2 volt into 75 ohms.
Isolation	At least 40 dB.
Return Loss	At least 30 dB.
Line Period	64 $\mu\text{s}^{\dagger}$ .
Line Sync Pulse	
Duration	4.7 $\mu\text{s}$ within 0.2 $\mu\text{s}$ .
Risetime	260 ns within 15%.
Field Period	20 $\text{ms}^{\dagger}$ .
Equalization Pulse	2.35 $\mu\text{s}$ within 0.1 $\mu\text{s}$ .
Sequence Duration	
First	2.5 H (lines) <sup>†</sup> .
Second	2.5 H (lines) <sup>†</sup> .
Field Sync Pulse	2.5 H (lines) <sup>†</sup> .
Sequence Duration	
Duration	27.3 $\mu\text{s}$ within 0.2 $\mu\text{s}$ .
Interval between Field Sync Pulses	4.7 $\mu\text{s}$ within 0.2 $\mu\text{s}$ .
<b>LINE DRIVE</b>	
Output Level	4 volts peak to peak within 0.2 V into 75 ohms (leading edge is coincident with leading edge of line sync).
Return Loss	At least 30 dB.
Rise- and Fall-time	260 ns within 15% .
Duration	7.15 $\mu\text{s}$ within 0.15 $\mu\text{s}$ .
<b>FIELD DRIVE</b>	
Output Level	4 volts peak to peak within 0.2 V into 75 ohms (negative going; leading edge is coincident with leading edge of first serrated pulse).
Return Loss	At least 30 dB.
Isolation	At least 40 dB.
Rise- and Fall-time	260 ns within 15% .
Duration	11 lines <sup>†</sup>
<b>COMPOSITE BLANKING</b>	
Output Level	4 volts peak to peak within 0.2 V into 75 ohms (negative going).
Return Loss	At least 30 dB.
Rise- and Fall-time	260 ns within 15% .
Duration	
Line Blanking	12 $\mu\text{s}$ within 0.2 $\mu\text{s}$ .
Field Blanking	25 lines (digitally determined plus 12 $\mu\text{s}$ ).
<b>PAL PULSE</b>	
Outputs	
Square wave	1 volt peak to peak within 0.05 V into 75 ohms.
Phasing	Transitions occur with each horizontal sync pulse.

	Positive transition is coincident with the leading edge of line sync pulse on lines with 135° or 225° (internally selected) burst phasing. Negative transition is coincident with leading edge of line sync pulse on lines with 135° or 225° (internally selected) burst phasing.
Pulse	4 volts peak to peak within 0.2 V into 75 ohms.
Phasing	Negative transition is coincident with the leading edge of line sync on lines with 135° or 225° (internally selected) burst phasing.
Duration	4.7 $\mu\text{s}$ within 0.2 $\mu\text{s}$
Return Loss	At least 30 dB.
Isolation	At least 40 dB.
Rise- and Fall-time	260 ns within 15% .
1 MHz REF FREQ	1.000000 MHz when subcarrier is 4.43361875 MHz (with 25 Hz offset).
Amplitude	1 volt peak to peak within 0.2 V into 75 ohms.
<b>BURST FLAG</b>	
Amplitude	4 volts within 0.4 V into 75 ohms (negative going).
Duration	2.2 $\mu\text{s}$ within 5%.
Return Loss	At least 30 dB.
Delay from Horizontal Sync	5.2 $\mu\text{s}$ within 5%.
<b>25 Hz</b>	
Output Level	1 volt peak to peak within 0.2 V into 75 ohms.
Phasing	Positive during fields 2 and 4.
Transition Timing	2 lines prior to Field Blanking.
<b>12.5 Hz</b>	
Output Level	1 volt peak to peak within 0.2 V into 75 ohms.
Phasing	Positive during fields 1 and 2.
Transition Timing	2 lines prior to Field Blanking.
<b>BURST</b>	
Half Amplitude Duration of Envelope	2.2 $\mu\text{s}$ within 5% (approximately 10 cycles).
Burst Delay	5.5 $\mu\text{s}$ within 0.2 $\mu\text{s}$ .
Burst Component	300 mV peak to peak within 3%.
V Component	212 mV peak to peak within 3%.
U Component	212 mV peak to peak within 3%.
Amplitude Ratio	1.00 within 1%.
$\left(\frac{U}{V}\right)$	
Amplitude on Successive Lines	Smaller is between 97% and 100% of the larger.
Phasing	135° within 1° and 225° within 1° on successive lines. Phasing between successive bursts is 90° within 1°.

<sup>†</sup>Digitally determined from 4.43361875 MHz.

**TABLE 1-4**

**POWER SUPPLY ELECTRICAL CHARACTERISTICS**

Characteristic	Performance Requirement
Power Connection	This instrument is designed for operation from a power source with its neutral at or near ground (earth) potential. It is not intended for operation from two phases of a multi-phase system, or across the legs of a single-phase, three-wire system.  It is provided with a three-wire power cord with a three-terminal polarized plug for connection to the power source. The third wire is directly connected to the instrument frame, and is intended to ground the instrument to protect operating personnel, as recommended by national and international safety codes.
Line Voltage Range	115 VAC      230 VAC
Low	90 V to 110 V      180 V to 220 V
Medium	104 V to 126 V      208 V to 252 V
High	112 V to 136 V      224 V to 272 V
Line Frequency Range	48 Hz to 66 Hz
Maximum Power Requirements at 230 VAC, 50 Hz	55 W maximum until OVEN TEMP NORMAL indicator is on. 0.25 A

**TABLE 1-5**

**PHYSICAL CHARACTERISTICS**

Characteristic	Information
Finish	Anodized aluminum front panel.
Dimensions (overall)	
141A	
Width	
Front-panel	17.2 inches.
Rear-panel	16.8 inches.
Length	19.3 inches (including knobs).
Height	3.5 inches; 3.8 inches including feet.

R141A	
Width	
Front-panel	19.1 inches.
Rear-panel	16.8 inches (excluding rack mounting hardware).
Length	19.7 inches (including front handles); 18.2 inches (excluding front-panel).
Height	3.5 inches.

**ENVIRONMENTAL CHARACTERISTICS**

The following environmental test limits apply when tested in accordance with the recommended test procedure. This instrument will meet the electrical performance requirements given in this section following an environmental test. Complete details on environmental test procedures, including failure criteria, etc., may be obtained from Tektronix, Inc. Contact your local Tektronix Field Office or representative.

**TABLE 1-6**

**ENVIRONMENTAL CHARACTERISTICS**

Characteristic	Information
Temperature	
Non-Operating	-40° to +65°C.
Operating	0°C to +50°C.
Altitude	
Non-Operating	To 50,000 feet.
Operating	To 15,000 feet.
Transportation	Qualified under National Safe Transit Committee test procedure 1A.
Vibration	
Operating	15 minutes along each axis at 0.015 inch. Vary the frequency from 10 to 50 to 10 c/s in 1-minute sweeps. Three minutes at any resonant point or at 50 c/s.
Shock	
Non-Operating	30g's, 1/2 sine, 11 ms duration, 2 shocks per axis.

**ACCESSORIES**

Standard accessories supplied with this instrument can be found on the last page of the Mechanical Parts List illustrations. For additional accessories, see the current Tektronix, Inc. catalog.

# SECTION 2

## OPERATING INSTRUCTIONS

Change information, if any, affecting this section will be found at the rear of the manual.

### INSTALLATION

#### Rackmounting

Complete information for mounting the Type R141A in a rack is given on the Rackmounting fold-out pages located in Section 9 at the back of the manual.

#### Operating Voltage

The Type R141A may be operated from either a 115-V or 230-V line voltage source. Quick-change line-voltage selector plugs, located under the fuse cover on the rear panel, change the transformer primary connections so the instrument can operate from one line voltage or the other (115 V or 230 V). In addition, the plugs permit one of three line voltage operating ranges to be selected. Table 2-1 lists all the voltage ranges that enable the instrument DC power supplies to regulate properly.

To convert to a different line voltage, proceed as follows:

1. Disconnect the Type R141A from the power source.

TABLE 2-1

115/230 Voltage Selector Plug Position	Range Selector Plug Position	Nominal Line (center) Voltage	Line Voltage Operating Range <sup>1</sup>
115 V	LO (Low)	100 VAC	90 to 110 VAC
	M (Medium)	115 VAC	104 to 126 VAC
	HI (High)	124 VAC	112 to 136 VAC
230 V	LO (Low)	200 VAC	180 to 220 VAC
	M (Medium)	230 VAC	208 to 252 VAC
	HI (High)	248 VAC	224 to 272 VAC

<sup>1</sup>Applicable when the line contains less than 2% total distortion.

2. Unscrew the two captive screws holding the fuse cover. Remove the cover with attached fuses.

3. To convert to a different line voltage (115 V to 230 V), pull out the 115/230 Voltage Selector plug (see Fig. 2-1). Rotate the plug 180° and insert it into the opposite set of holes. The 115/230 Voltage Selector plug is located in the upper position for 115-V operation and in the lower position for 230-V operation.

4. To change the line-voltage operating range (LO, M or HI), pull out the Range Selector plug (see Fig. 2-1) and

insert it in the desired hole locations. Select a range with a center voltage (see column 3 in Table 2-1) closely corresponding to the line voltage that will be applied in regular instrument operation.

5. Re-install the cover with two captive screws and fuses. Be sure the cover fits firmly against the rear panel. This indicates that the line fuses are seated properly in the fuse clips.

6. Before applying power to the instrument, check that the indicating tabs on the selector plugs protrude through the proper holes in the cover for the correct line voltage and the proper operating range.

#### CAUTION

The Type R141A should not be operated with the 115/230 Voltage Selector and/or Range Selector plugs in the wrong position for the line voltage applied. Operation of the instrument with either plug in the wrong position may cause incorrect operation or damage to the instrument.

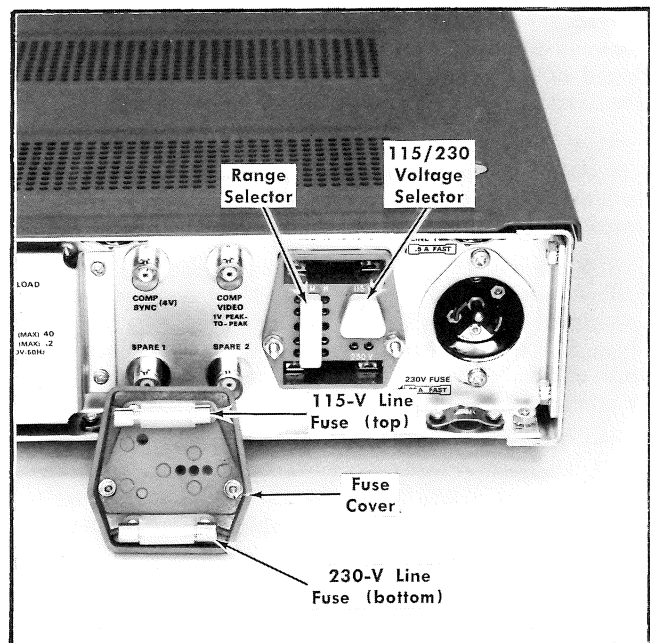

Fig. 2-1. Location of Range and Voltage Selector plugs with fuse cover removed. The plugs as shown are set for 115-V medium range operation.

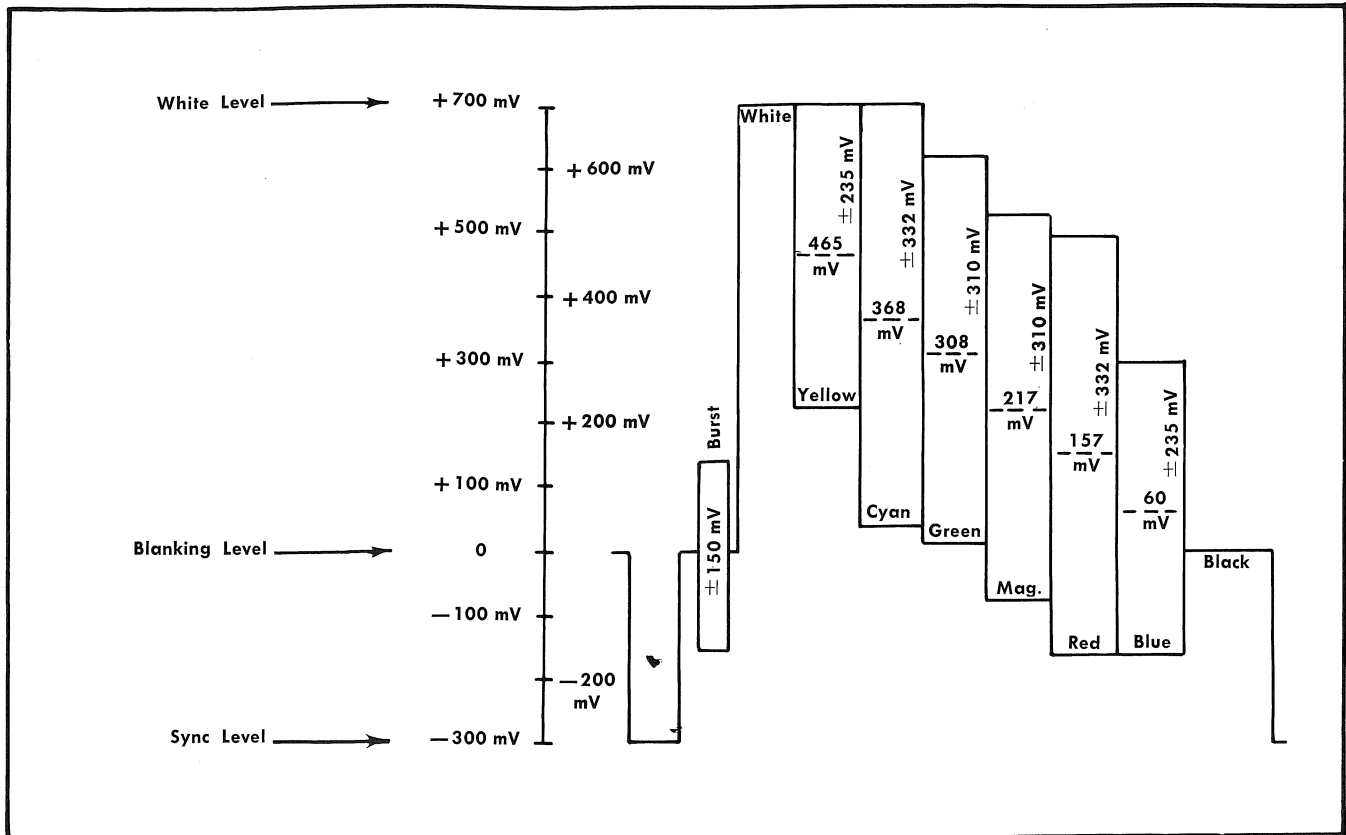

Fig. 2-2. PAL colour bar test signal with 100% peak white saturated colour stripes of 75% amplitude (EBU colour bar pattern). For two colours each, full drive to upper limit (yellow, cyan) and lower limit (red, blue) respectively.

### BASIC INFORMATION

Frequent check-out of colour TV broadcast equipment is essential in providing realistic and accurate presentation of taped or live colour scenes. In addition, rapid check-out of the signal monitoring instruments is highly desirable.

Type R141A provides a high-quality composite video signal complete with colour components, suitable for checking calibration and operation of vectorscopes and TV waveform monitors.

The various components which comprise the composite colour video signal can be added or removed from the composite signal by front-panel operational controls on the Type R141A. This permits the simulation of various broadcast equipment troubles, such as loss of sync signals, U or V components, etc.

The Type R141A also serves as an excellent teaching aid, since the composite video signal can be "built up", one component at a time. Also, both the familiar staircase and colour bar test signals are available as part of the composite video signal.

Fig. 2-2 illustrates the standard PAL colour bar test signal. This signal is useful for checking luminance, hue and saturation levels.

Luminance is brightness as perceived by the eye. This is represented by the amplitudes of the step levels of the colour bar signal between black and white levels. Since

the eye is more sensitive to green and less to blue light of equal energy, green is a bright colour, blue is a dark colour as conveyed by the luminance signal to monochrome TV receivers. The colour bar steps are therefore arranged in descending luminance order starting with yellow, the brightest colour, and ending with blue, the least bright colour.

Chrominance consists of two additional quantities; hue and saturation. Hue is the attribute of colour perception that determines whether the colour is red, blue, green, or other. White, black and gray are not considered hues. In colour TV systems, the hue is encoded as a phase angle of the signal with respect to a reference frequency (burst signal). See Fig. 2-3 (B).

Saturation is the degree to which a colour (or hue) is diluted by white light in order to distinguish between vivid and weak shades of the same hue. For example, vivid red is highly saturated and pink or pastel red has little saturation. One-hundred percent saturation represents full hue with no white dilution. In a vector display, saturation is indicated by the length of the vector. See Fig. 2-3 (A).

The standard modulated staircase test signal is illustrated in Fig. 2-4. The staircase for PAL normally consists of 5 steps (6 levels), each of which is modulated by the sub-carrier frequency (4.43 MHz in PAL). The steps are equally spaced between black level and white level. Staircase test signals are useful for checking presence of non-linearity in video stages. Typical tests made with a modulated staircase are differential gain and differential phase.



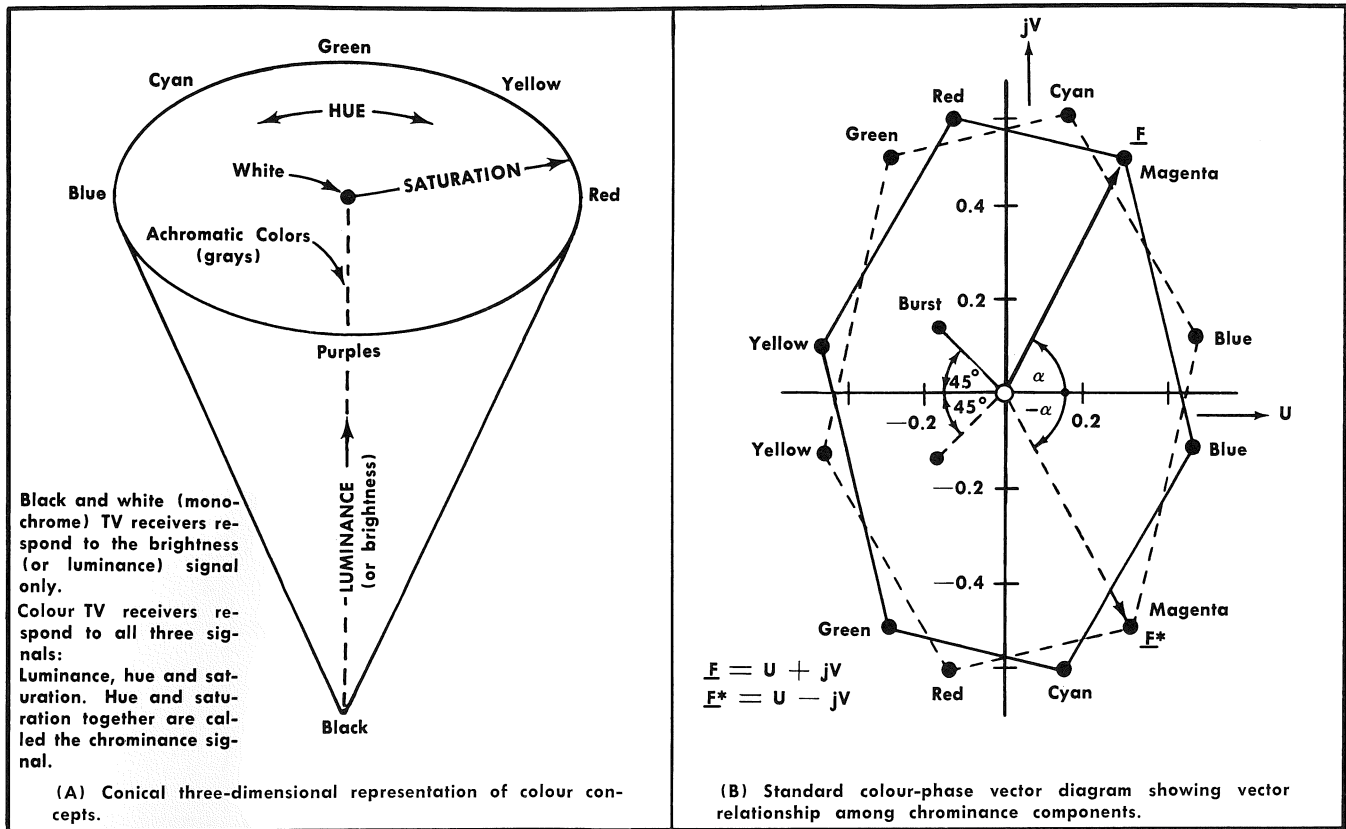

Fig. 2-3. Illustrations showing the relationship between the basic colour concepts and the standard colour-phase vector diagram.

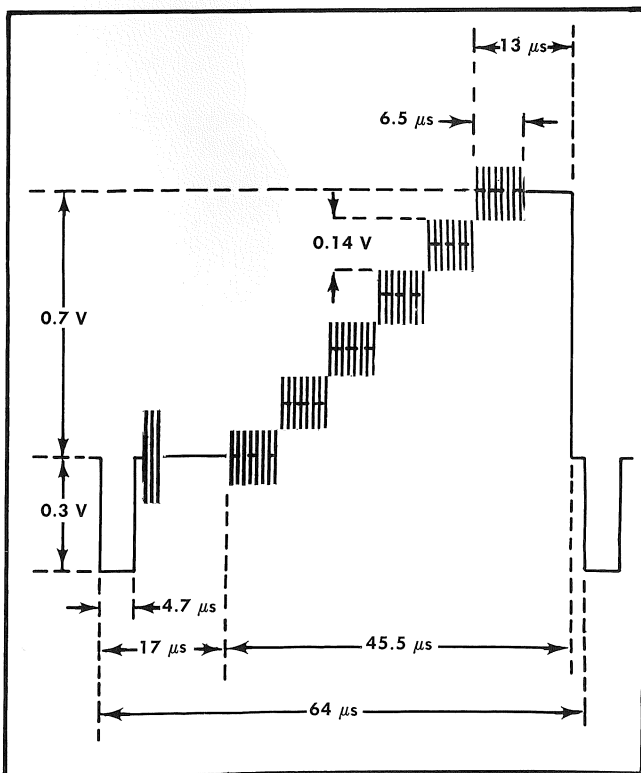

Fig. 2-4. Modulated staircase output signal.

Differential gain is a change in colour subcarrier amplitude as a function of luminance. In the reproduced colour picture, presence of differential gain will cause distortion of the saturation in the areas between light and dark portions of the screen.

Differential phase is a phase modulation of the chrominance signal by the luminance signal. With differential phase present, colour (hue) will vary with scene brightness in the reproduced colour picture.

## CONTROLS AND CONNECTORS

### Introduction

A brief description of the function or operation of the Type R141A controls and front- and rear-panel output connectors is provided here (see Fig. 2-5).

### Front-Panel Controls

The following controls (except the POWER switch) are used to select the various signal conditions which comprise the Composite Video output signal:

**COLOUR BAR** Consists of five lever switches to control signal elements which make up the standard colour bar test signal.

U Lever Switch:

Up position turns on the U (0°-180°

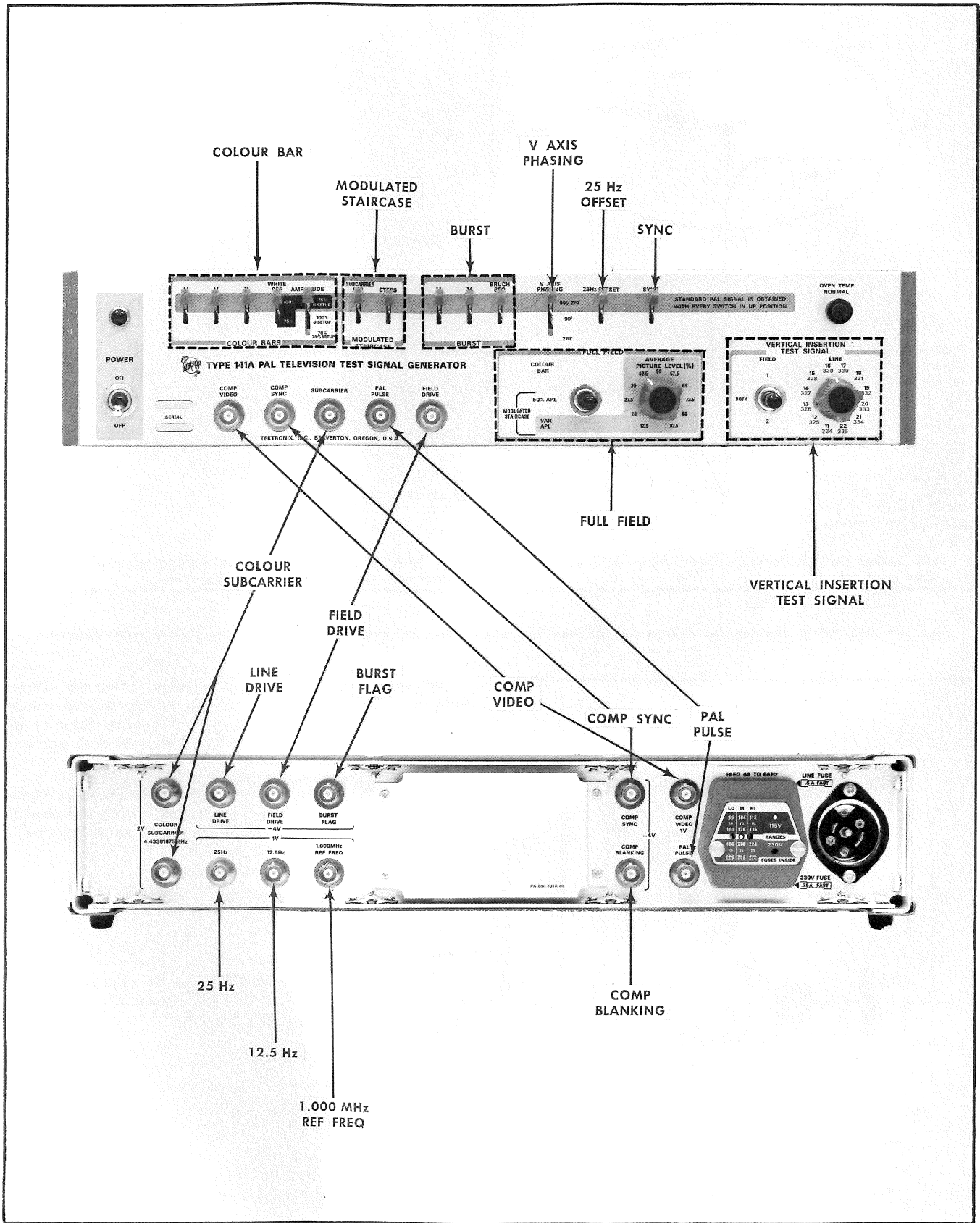

Fig. 2-5. Front- and rear-panel controls and connectors on the Type 141A PAL Television Test Signal Generator.

axis) component of colour bar signal. Down position turns off the U component.

V Lever Switch:

Up position turns on the V (90°-270° axis) component of colour bar signal. Down position turns off the V component.

Y Lever Switch:

Up position turns on the luminance component of colour bar. Down position turns off the Y component.

WHITE REF:

Controls white reference level only when AMPLITUDE switch is in the 75%, 0 SETUP position.

100% position sets the white reference at the normal or 100% amplitude level.

75% position sets the white reference at 75% of the amplitude between blanking and normal (100%) white level.

AMPLITUDE:

Three position switch to select the amplitude and setup levels of the colour bar signal.

75%, 0 SETUP position provides colour bars with 75% amplitude, 100% saturation and 0% setup. The white reference level may be either 75% or 100% as selected by the WHITE REF switch. With the white reference at 100%, this position provides the standard EBU test signal.

100%, 0 SETUP position provides colour bars with 100% amplitude, 100% saturation, 0% setup and white reference at 100%. WHITE REF switch has no effect in this position.

75%, 25% SETUP position provides colour bars with chrominance signal at 75% amplitude. Luminance signal contains a 25% (175 mV) setup during all colour bars. White reference is at the 100% level irrespective of the WHITE REF switch position. This signal is referred to as '95% BBC bars' in the United Kingdom.

MODULATED STAIRCASE

Consists of two lever switches to control signal elements which make up the standard staircase test signal.

SUBCARRIER MOD:

Up position turns on chroma (bursts of 4.43 MHz sine waves).

Down position turns off modulation.

STEPS:

Up position turns on staircase (five steps, 140 mV per step).

Down position turns off staircase.

BURST

Consists of three lever switches to control burst characteristics.

U Lever Switch:

Up position turns on the U component of burst.

Down position turns off the U component.

V Lever Switch:

Up position turns on the V component of burst.

Down position turns off the V component.

BRUCH SEQ:

Up position provides Bruch sequence for burst.

Down position provides NTSC sequence for burst.

V AXIS PHASING

Consists of a three-position lever switch to control phase of V axis signal.

90°/270°:

V axis alternates between 90° and 270° at H rate.

90°:

V axis is locked to 90°.

270°:

V axis is locked to 270°.

25 Hz OFFSET

Up position offsets subcarrier frequency applied to horizontal counter circuitry by 25 Hz.

Down position removes 25 Hz offset.

SYNC

Up position provides horizontal and vertical sync pulses (at rates of 15,625 Hz and 50 Hz respectively) for composite video output. Amplitude is 300 mV.

Down position removes both horizontal and vertical sync from the composite video signal (Comp Sync output is not affected).

FULL FIELD

Consists of a three position lever switch and an eleven position rotary switch to control line video test signals.

COLOUR BAR/MODULATED STAIRCASE Switch:

COLOUR BAR position provides a colour bar test signal, with colour bars in descending luminance order, on each active video line. 50% APL position provides a five step (six level) modulated staircase signal on each active video line. VAR APL position provides a modulated staircase signal on every fourth active video line and a selectable luminance level on three of each four active video lines.

AVERAGE PICTURE LEVEL Switch:

This control provides selection of average luminance level. (Average is 12.5% to 87.5%.)

VERTICAL INSERTION TEST SIGNAL

Consists of a three-position toggle switch and a twelve-position rotary switch to provide selection of line and field to which the vertical insertion test signal is applied.

## Operating Instructions—Type 141A/R141A

### LINE Switch:

Provides selection of any line from line 11 through line 22 or line 324 through line 335 to which VITS is applied.

### FIELD Switch:

Provides selection of Field 1, Field 2 or BOTH to which VITS is applied.

### POWER

#### Switch:

Toggle switch turns main power ON and OFF.

#### Light:

Indicates that the POWER switch is on and the instrument is connected to a line voltage source.

### OVEN TEMP NORMAL

#### Light:

When lit, indicates that the Master Oscillator crystal oven is at normal operating temperature.

## Output Connectors

All output signals are via BNC type connectors, and have a 75 ohm source impedance. For proper operation, each output, when in use, must drive a 75 ohm load.

### COMP VIDEO (Front- and rear-panel)

Composite video signal, consisting of vertical and horizontal sync and video test signals as selected by front-panel controls. For characteristics, see Front-Panel Controls and Section 1 Specification. Also, see Field Blanking Details 1 pull-out sheet in rear of manual.

### COMP SYNC (Front- and rear-panel)

Continuous sync train consisting of horizontal sync pulses at a 15,625 Hz rate and vertical sync pulses at a 50 Hz rate. Signal includes complete vertical detail with equalizing pulses. Amplitude is 4 V P-P, negative-going.

### SUBCARRIER (1 front- and 2 rear-panel)

Sine wave output at subcarrier frequency (4.43361875 MHz  $\pm$  5 Hz). Amplitude is 2 V P-P.

### COMPOSITE BLANKING (Rear-panel)

Negative-going composite blanking signal containing both line-rate and field-rate signals. Line blanking duration is 12  $\mu$ s and field blanking duration is 25 lines. Amplitude of composite signal is 4 V P-P.

### PAL PULSE (Front- and rear-panel)

Negative-going pulse or square wave for use with PAL encoders to maintain correct phase of the V axis signals. Amplitude and phasing are internally selected and are independent of the front-panel V AXIS PHASING switch.

Square wave output: Amplitude is 1 V P-P. Transitions occur with each horizontal sync pulse. The positive transition is coincident with the leading edge of the line sync pulse on lines with either 135° or 225° burst phasing (as selected internally). The negative transition is coincident with the leading edge of the line sync pulse on lines with either 135° or 225° burst phasing (as

selected internally). For example, if lines with 135° burst phasing are selected for the positive transitions, the negative transitions will occur on lines with 225° burst phase. Encoders manufactured in the United Kingdom normally require the 1 V square wave signal.

Pulse output: Amplitude is 4 V P-P. The negative transition is coincident with the leading edge of the line sync pulse on lines with either 135° or 225° burst phasing (as selected internally). Duration of the pulse is 4.7  $\mu$ s. German-made encoders normally require the 4 V pulse signal.

### LINE DRIVE (Rear-panel)

Negative-going drive pulse for use by colour television cameras. Amplitude is 4 V P-P. Leading edge is coincident with the leading edge of line sync. Duration of pulse is 7.15  $\mu$ s.

### FIELD DRIVE (Front- and rear-panel)

Negative-going field drive pulse for use by colour television cameras. Front-panel output is also useful as a field rate signal for triggering oscilloscopes. Amplitude at both connectors is 4 V P-P. Leading edge is coincident with the leading edge of the first serrated pulse. Duration of the output pulse is 11 lines.

### 12.5 Hz (Rear-panel)

Negative-going pulses at 12.5 Hz rate. Width is 40 ms; amplitude is 1 V P-P. Phase-locked to horizontal sync. Useful for triggering display equipment to view individual fields of the four-field sequence.

### 25 Hz (Rear-panel)

Negative-going pulses at 25 Hz rate. Width is 20 ms; amplitude is 1 V P-P. Phase-locked to horizontal sync. Useful for triggering display equipment to view Field 1 or Field 2 of two-field sequence.

### BURST FLAG (Rear-panel)

Negative-going pulses at horizontal rate. Coincident with burst signal. Duration is 2  $\mu$ s; amplitude is 4 V P-P. Phase-locked to subcarrier. When BRUCH SEQ switch is in up position, output signal follows Bruch sequence. In down position, BURST FLAG signal follows NTSC sequence.

### 1.000 MHz REF FREQ (Rear-panel)

Negative-going pulses at 1.000 MHz rate. Frequency-referenced to subcarrier oscillator. Width is approx. 0.7  $\mu$ s; amplitude is 1 V P-P. Useful for checking frequency of subcarrier oscillator against a standard frequency.

### NOTE

25 Hz OFFSET switch should be in the "up" position when using the 1.000 MHz REF FREQ as a frequency check.

## Test Setup Chart

Fig. 2-13 shows a drawing of the front- and rear-panel controls and connectors. This chart can be reproduced and used as a test setup record for special measurements and applications, or it may be used as a training aid for operation of the Type R141A.



### FIRST-TIME OPERATION

The following procedure demonstrates the use of the controls and connectors of the Type R141A. Use of the Type R141A with three different display instruments is outlined for the convenience of the user. It is assumed that a video waveform monitor is available. A Vectorscope is essential if phase characteristics of the composite video output are to be observed. An oscilloscope is useful for observing sync, drive and other pulse outputs. It may be used to display all outputs except for phase characteristics.

#### Procedure 1

A Type RM529 Waveform Monitor is used as a display device in the following steps.

1. Check that the line voltage selector plugs are in proper positions for the line voltage to be applied. (See Installation). Connect the Type R141A to the power source and turn on the POWER switch.

2. Connect the COMP VIDEO output on the Type R141A to the A Video Input on the Type RM529 through a 75-ohm coaxial cable. If the other A Video Input connector is

not used, connect a 75-ohm terminating resistor to the unused connector.

3. While the instrument is warming up (at least 5 minutes), set the instrument front-panel controls to these positions:

#### Type R141A

COLOUR BAR switches	All up
MODULATED STAIRCASE switches	All up
BURST switches	All up
V AXIS PHASING	90°/270°
25 Hz OFFSET	Up
SYNC	Up
FULL FIELD	
COLOUR BAR/MODULATED STAIRCASE	COLOUR BAR
AVERAGE PICTURE LEVEL	50
VERTICAL INSERTION TEST SIGNAL:	
LINE	17/330
FIELD	BOTH

#### Type RM529

Vertical:	
Input	A
Position	Centered
Response	Flat
Volts Full Scale	1.0 (Calib)
DC Restorer	On
Calibrator	Full Scale
Focus	Sharp Trace
Intensity	As desired
Scale Illum	Fully CW
Horizontal:	
Position	Centered
Display	2 line
Mag	X1
Line Selector	17
Field	One
Sync	Int

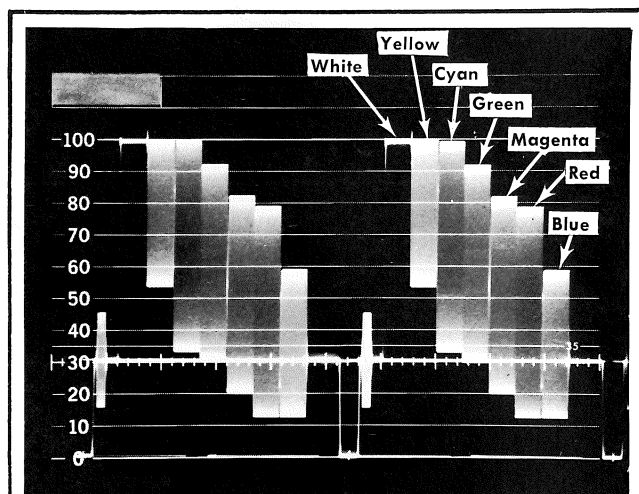

(A) 75%-amplitude encoded colour-bar test signal.

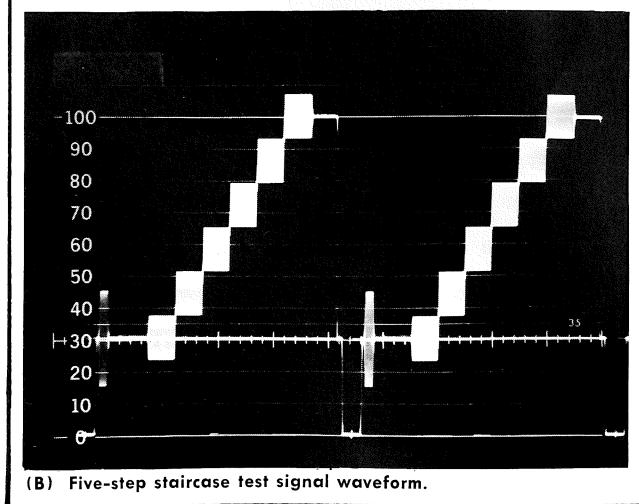

(B) Five-step staircase test signal waveform.

Fig. 2-6. Test signals available at COMP VIDEO output connector.

4. The display should be 2 lines of composite video containing standard colour bar test signals.

5. With the Type RM529 Vertical Position control, set the sync tips on the 0 graticule line. White level on the waveform should be at the 100 graticule line; black and blanking levels should be at 30 (this indicates 0% setup level). Burst should be present between the sync pulse and the white luminance step. See Fig. 2-6A.

6. Change the COLOUR BAR U and V switches to down positions. Note that the display is now showing only the luminance (Y) component of the colour bar signal. Return the U and V switches to up positions.

7. Change the COLOUR BAR Y switch to the down position. Note that the display now shows only the chrominance components of the colour bar signal. Return the Y switch to the up position.

8. With the Type RM529 Vertical Position control, move the display down until the blanking level is at the 0 grati-

## Operating Instructions—Type 141A/R141A

cule line. Set the Volts Full Scale Variable control so that white level on the waveform is at the 100 graticule line. Change the Type R141A COLOUR BAR WHITE REF switch to the 75% position. Note that white level reference is now at 75 on the graticule (representing 75% of amplitude between blanking and normal white level).

Return the WHITE REF switch to the up position (100%); set the Type RM529 Volts Full Scale Variable control to the Calib position and set the Vertical Position control so the the sync tips are at the 0 graticule line.

9. Change the AMPLITUDE switch to the 100%, 0 SETUP position. Note that both the luminance and chrominance components of the colour bar signal have increased in amplitude. See Section 1 Specification, TABLE 1-2 for individual bar amplitudes.

10. Change the AMPLITUDE switch to the 75%, 25% SETUP position. Chrominance amplitudes will be the same as when the AMPLITUDE switch is in the upper (75%, 0 SETUP) position, but luminance levels will be elevated by 175 mV ( $700 \text{ mV} \times 25\%$ ). See Section 1 Specification, TABLE 1-2 for individual bar amplitudes.

Return the AMPLITUDE switch to the 75%, 0 SETUP position.

11. Change the FULL FIELD COLOUR BAR/MODULATED STAIRCASE switch to the 50% APL position.

The display should now be 2 lines of composite video containing standard modulated staircase test signals.

The staircase should contain 5 steps (6 levels), each step being 140 mV in amplitude. The subcarrier modulation (4.43 MHz) on each step should also be 140 mV in amplitude. See Fig. 2-6B.

12. Change the MODULATED STAIRCASE SUBCARRIER MOD switch to the down position. Note that the display now shows only the staircase component of the test signal. Return the SUBCARRIER MOD switch to the up position.

13. Change the MODULATED STAIRCASE STEPS switch to the down position. Note that the display now shows only the chrominance (4.43 MHz modulation) component of the test signal. Return the STEPS switch to the up position.

14. Change the SYNC switch to the down position. Note that the sync component of the composite video waveform is now removed, leaving only the video signal (burst and staircase). Return the SYNC switch to the up position.

15. Change the Type RM529 Display switch to 2 Field and set the Mag switch to X25. Turn the Horizontal Position control until the display is a series of lines containing staircase signals (rather than displaying the vertical sync group). Note that each line has a staircase signal.

16. Change the Type R141A FULL FIELD COLOUR BAR/MODULATED STAIRCASE switch to VAR APL. Note that every fourth line has a staircase signal and the remaining 3 out of 4 lines has a fixed level for the line duration. Rotate the AVERAGE PICTURE LEVEL control between 12.5 and 87.5. Note that the fixed level of the lines (between staircase signal lines) changes from blanking level to white level in 10% increments. Return the COLOUR BAR/MODULATED STAIRCASE switch to the 50% APL position.

17. Change the Type RM529 Mag switch to X5 and turn the Horizontal Position control to center the vertical sync

pulse on the screen. Note that a staircase test signal appears on one of the lines during the field blanking interval. See Fig. 2-7.

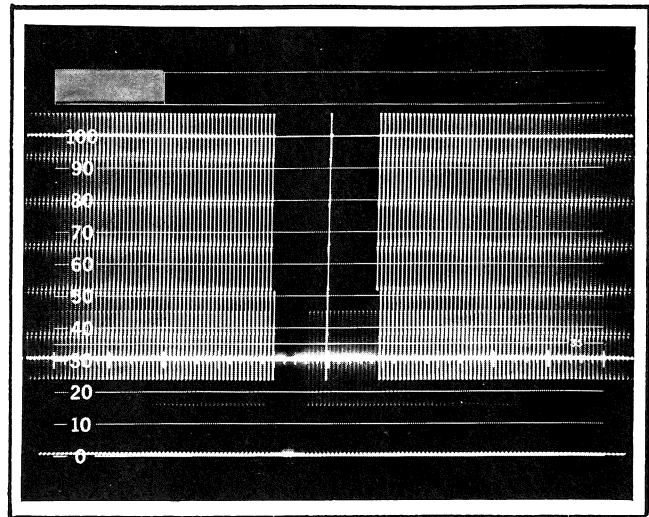

Fig. 2-7. Field blanking interval, including staircase vertical insertion test signal (VITS).

18. Rotate the VERTICAL INSERTION TEST SIGNAL LINE control between the 11/324 and 22/335 positions. The staircase test signal should shift from line to line as the control is rotated. The LINE control indicates which line contains the test signal. Changing the FIELD switch to 1 or 2 causes the test signal to appear only in the field selected.

## Procedure 2

A Type 545B Oscilloscope with a Type 1A1 Plug-In Unit is used as a display device in the following steps.

The oscilloscope used must have a bandwidth that is flat (uniform) in response from DC to approximately 5 MHz. An oscilloscope with a bandwidth of DC to 15 MHz ( $-3 \text{ dB}$  frequency) or greater and a deflection factor of 0.1 V/cm or better is recommended. If the oscilloscope has insufficient bandwidth, the subcarrier and colour bar chrominance signals will not be displayed with correct amplitude in relation to other signal components.

1. Connect the COMP VIDEO output on the Type R141A to one end of a 75-ohm coaxial cable. Connect a 75-ohm termination to the other end of the cable and then connect the termination to Input 1 on the Type 1A1 Plug-In Unit. Connect another 75-ohm cable from the LINE DRIVE output on the rear of the Type R141A to the Time Base A Trigger Input connector on the Type 545B. See Fig. 2-8.

2. Set the Type R141A front-panel controls as indicated in Step 3 of Procedure 1.

3. Set the Type 545B and Type 1A1 controls as follows:

### Type 545B

Since only Time Base A will be used in this procedure, settings of Time Base B, Delay-Time Multiplier and Amplitude Calibrator will not be noted.

Time Base A:	
Stability	Preset
Triggering Level	0 (centered)
Triggering Mode	AC
Trigger Slope	—Ext
Time/Cm	10 $\mu$ s
Variable	Calibrated
Horizontal Display	A
5 $\times$ Magnifier	Off
Horizontal Position	Centered display
Intensity	As desired
Focus and Astigmatism	Sharp trace
Scale Illum	As desired

**Type 1A1**

Since only Channel 1 will be used in this procedure, settings of Channel 2 controls will not be noted.

Channel 1:	
Position	Centered
Variable Volts/Cm	Calib
Pull For Invert	In
Mode	Ch 1
Volts/Cm	.2
Input Selector	DC

4. Operate the Type R141A controls in the same sequence as Steps 4 through 14 in Procedure 1. The displays will be the same as those obtained with the Type RM529, except

there is no 0 to 100 scale on the graticule and the display will consist of approximately 1½ TV lines.

5. Change the cable from the LINE DRIVE connector on the Type R141A to the FIELD DRIVE connector.

Change the A Time/Cm control on the Type 545B to .2 ms.

6. Turn the A Triggering Level on the Type 545B to the point that provides a display consisting of a series of TV lines containing staircase signals (rather than displaying the vertical blanking interval). Note that each line has a staircase signal.

7. Change the Type R141A FULL FIELD COLOUR BAR/MODULATED STAIRCASE switch to VAR APL. Note that every fourth line has a staircase signal and the remaining 3 out of 4 lines have a fixed level for the line duration. Rotate the AVERAGE PICTURE LEVEL control between 12.5 and 87.5. Note that the fixed level of the lines (between staircase signal lines) changes from blanking level (0) to white level (100) in 10% increments. Return the COLOUR BAR/MODULATED STAIRCASE switch to the 50% APL position.

8. Turn the A Triggering Level control on the Type 545B to the point that provides a display of the vertical blanking interval. The blanking interval will have a duration of approximately 8 centimeters. Note that a staircase test signal appears on one of the lines during the blanking interval.

9. Rotate the VERTICAL INSERTION TEST SIGNAL LINE control between the 11/324 and 22/335 positions. The staircase test signal should shift from line to line as the control is rotated. The LINE control indicates which line contains the

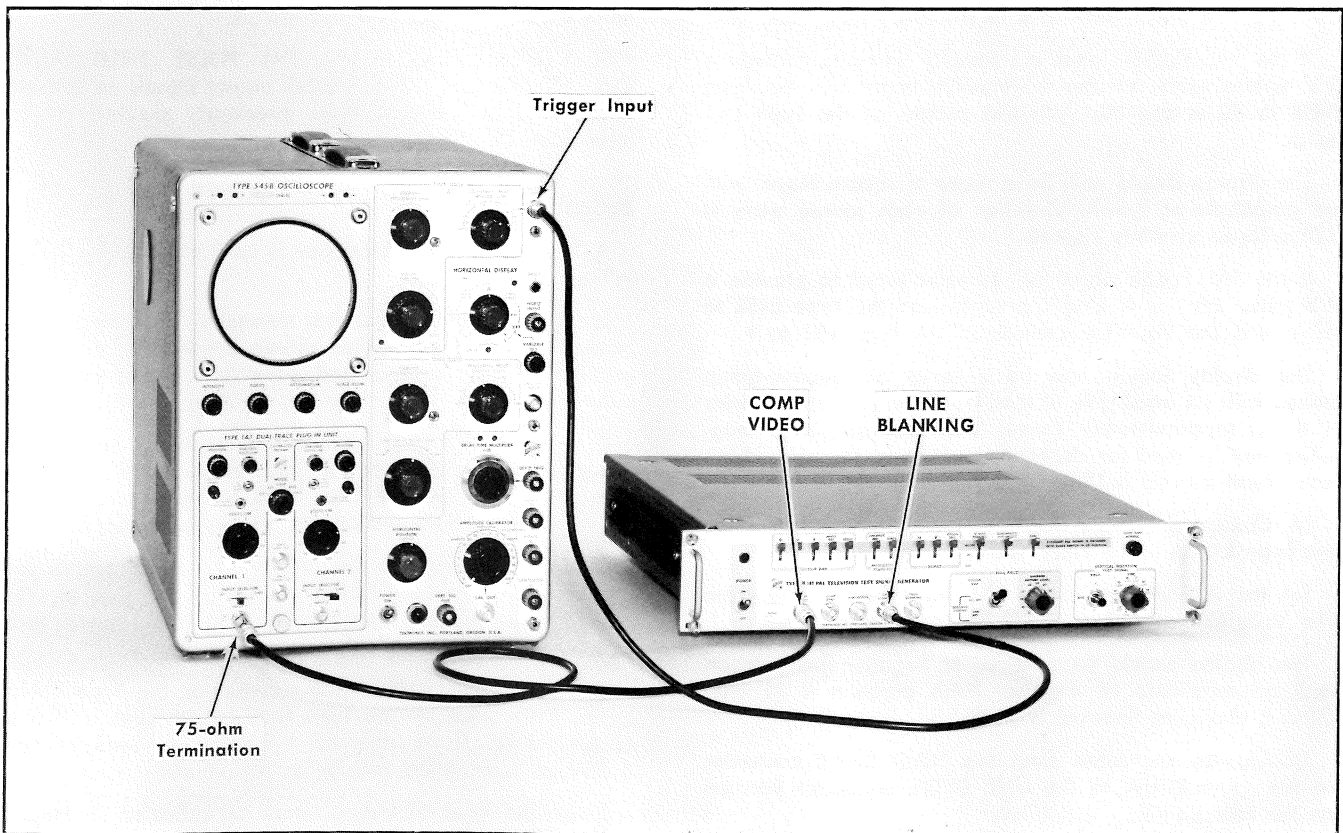

Fig. 2-8. Initial test equipment setup for First-Time Operation, Procedure 2.

## Operating Instructions—Type 141A/R141A

test signal. Changing the FIELD switch to 1 or 2 causes the test signal to appear only in the field selected.

10. Change the cable from the COMP VIDEO connector on the Type R141A to the COMP SYNC connector.

Change the Volts/Cm control on the Type 1A1 Plug-In Unit to 2.

The display should now consist of vertical and horizontal sync pulses. The sync pulses are negative in polarity with an amplitude of 4 volts (2 cm).

11. Change the cable from the COMP SYNC connector on the Type R141A to the SUBCARRIER connector.

Remove the cable between the FIELD DRIVE connector and the A Trigger Input connector on the Type 545B. Change the A Trigger Slope to —Int and set the A Time/Cm to .2  $\mu$ s. Set the Volts/Cm control on the Type 1A1 Plug-In Unit to 1. Adjust the A Triggering Level on the Type 545B for a stable display.

The display should now be sine waves at the subcarrier frequency (4.43 MHz) with an amplitude of 2 V P-P (2 cm).

12. Change the cable from the SUBCARRIER connector on the Type R141A to the COMPOSITE BLANKING connector.

Change the Volts/Cm control on the Type 1A1 to 1 and set the A Time/Cm control on the Type 545B to 50  $\mu$ s.

The display should now consist of line and field blanking pulses. The pulses are negative in polarity with an amplitude of 4 V (4 cm).

13. Change the cable from the COMPOSITE BLANKING connector on the Type R141A to the PAL PULSE connector.

If the PAL PULSE signal is internally wired to provide a 1 V square wave, set the A Time/Cm control on the Type 545B to 50  $\mu$ s and the Volts/Cm control on the Type 1A1 to .5.

The display should now be a series of square waves with an amplitude of 1 volt. Duration of each square wave is 128  $\mu$ s (approximately 2½ cm).

If the PAL PULSE signal is internally wired to provide a 4 V pulse, set the A Time/Cm control on the Type 545B to 50  $\mu$ s and the Volts/Cm control on the Type 1A1 to 1.

The display should now be a series of negative-going pulses with an amplitude of 4 volts. Duration of each pulse is 4.7  $\mu$ s (approximately 1 mm). The oscilloscope X5 magnifier may be used for closer observation of the pulse duration. Pulse interval is 128  $\mu$ s.

14. Change the cable from the PAL PULSE connector on the Type R141A to the FIELD DRIVE connector.

Set the A Time/Cm control on the Type 545B to 5 ms. The Volts/Cm control on the Type 1A1 should be set to 1.

The display should be a series of negative-going pulses with an amplitude of 4 volts. Pulse duration is 11 lines (704  $\mu$ s) and pulse interval is 20 ms.

15. Change the cable from the FIELD DRIVE connector on the Type R141A to the LINE DRIVE connector (located on the rear panel).

Change the A Time/Cm control on the Type 545B to 20  $\mu$ s.

The display should now be a series of negative-going pulses with an amplitude of 4 volts. Pulse duration is 7.15  $\mu$ s and pulse interval is 64  $\mu$ s.

16. Change the cable from the LINE DRIVE connector on the Type R141A to the BURST FLAG connector (located on the rear panel).

The display should now be a series of negative-going pulses with an amplitude of 4 volts. Pulse interval is 64  $\mu$ s and pulse duration is approximately 2.2  $\mu$ s.

17. Change the cable from the BURST FLAG connector on the Type R141A to the 25 Hz connector.

Change the A Time/Cm control on the Type 545B to 10 ms and change the Volts/Cm control on the Type 1A1 to .5.

The display should now be a series of negative-going pulses with an amplitude of 1 volt. Pulse interval is 40 ms and pulse duration is approximately 20 ms.

18. Change the cable from the 25 Hz connector on the Type R141A to the 12.5 Hz connector.

Change the A Time/Cm control on the Type 545B to 20 ms.

The display should now be a series of negative-going pulses with an amplitude of 1 volt. Pulse interval is 80 ms and pulse duration is approximately 40 ms.

19. Change the cable from the 12.5 Hz connector on the Type R141A to the 1.000 MHz REF FREQ connector.

Change the A Time/Cm control on the Type 545B to 1  $\mu$ s.

The display should now be a series of negative-going pulses with an amplitude of 1 volt. Pulse interval is 1  $\mu$ s and pulse duration is approximately 0.7  $\mu$ s.

20. COLOUR SUBCARRIER, PAL PULSE, FIELD DRIVE, COMP SYNC, and COMP VIDEO output signals on the rear panel are the same as those previously checked on the front panel.

## Procedure 3

A Type R520 PAL Vectorscope is used as a display device in the following steps.

The Vectorscope provides a means of displaying phase characteristics as well as amplitude information, permitting graphic analysis of hue and saturation in the composite video signal.

R, G, B, Y, V and U luminance components can also be conveniently displayed on the line sweep graticule of the Type R520 PAL. See the Type R520 PAL instruction manual, operating instructions section, for measurement details.

Differential phase and differential gain measurements can be made using the MODULATED STAIRCASE test signal. The procedure for making measurements is detailed in the Type R520 PAL instruction manual.

1. Connect the COMP VIDEO output on the Type R141A to the Ch A input on the Type R520 PAL through a 75-ohm coaxial cable. If the other Ch A input is not used, connect a 75-ohm terminating resistor to the unused connector.

2. Set the Type R141A controls as indicated in Step 3 of Procedure 1.

3. Set the Type R520 PAL controls as follows:



**Type R520 PAL**

Signal Selector	Full Field, A $\phi$ , Ch A
Ch A 100%-75%-Max Gain	75%
Ch A Gain	Cal
A Phase	As is
Ch B 100%-75%-Max Gain	75%
Ch B Gain	Cal
B Phase	As is
Ref	Burst
Function Selector	Vector PAL
Luminance Gain	Cal
Display	Both
Calibrated Phase	0°
Intensity	Normal brightness
Focus	Well defined display
Scale Illum	As desired
Field	1
Sync	Int
Vert Position	Midrange
Horiz Position	Midrange

4. The display should be a vector presentation of the chrominance portion of the colour bar test signal.

5. Adjust the A Phase control on the Type R520 PAL to align the burst vectors with their respective 135° and 225° positions.

With the Type R520 PAL in proper calibration, the burst tips should coincide with the 75% marks on the graticule and all colour vectors (dots) should appear in their respective inner boxes (see Fig. 2-9).

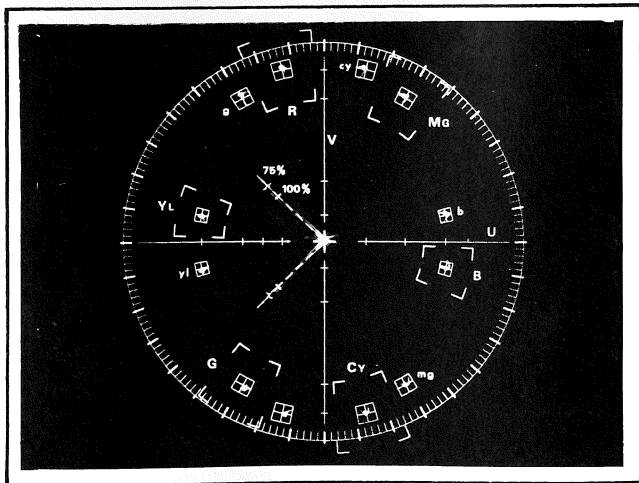

Fig. 2-9. Vector presentation of the colour bar test signal. Position of the dots within the smaller boxes indicates that the displayed colour vectors are within  $\pm 3^\circ$  phase and  $\pm 5\%$  amplitude limits.

6. Change the COLOUR BAR U lever switch on the Type R141A to the down position.

The display should be a vertical row of 6 dots (excluding the center dot) plus the 135° and 225° burst vectors. See Fig.

2-10A. This display contains only the V component of the colour bar and is useful for setting up V amplitudes of the colour segments. Inscribed scale markings on the graticule facilitate the check.

Return the U lever switch to the up position.

7. Change the COLOUR BAR V lever switch on the Type R141A to the down position.

The display should be a horizontal row of 6 dots (excluding the center dot) plus the 135° and 225° burst vectors. See Fig. 2-10B. This display contains only the U component of the colour bar and is useful for setting up U amplitude of the colour segments. Inscribed scale markings on the graticule facilitate the check.

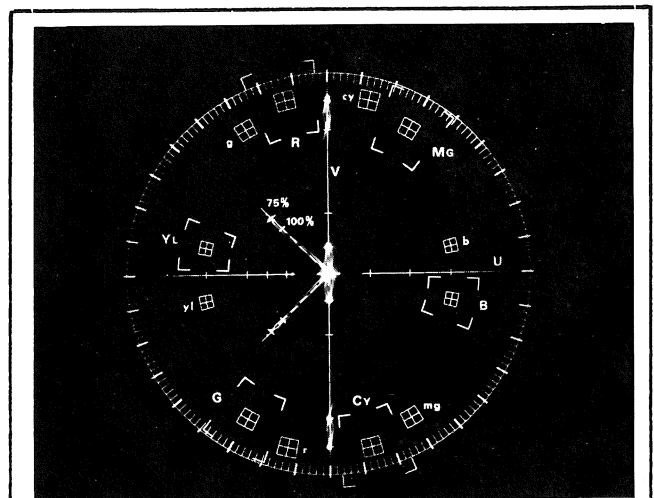

(A) V component of colour bar test signal.

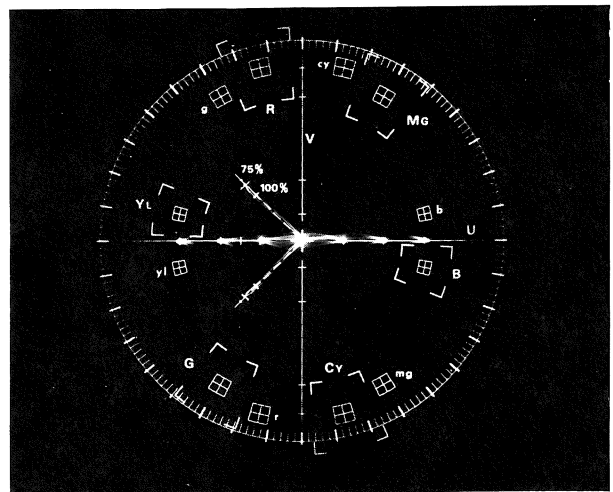

(B) U component of colour bar test signal.

Fig. 2-10. Vector display of colour bar test signal containing only V or U components.

Return the V lever switch to the up position.

8. In the previous two steps, if the U and V amplitude (dots) fell on or very near their corresponding scale markings, then

## Operating Instructions—Type 141A/R141A

all colour vectors should fall within their respective inner boxes on the graticule (indicating that they are within  $\pm 3^\circ$  phase and  $\pm 5\%$  amplitude error limits) when both U and V components are present in the colour bar signal. See Fig. 2-9.

9. Change the BURST BRUCH SEQ lever switch on the Type R141A to the down position. Note that the vector display now has jitter. Return the BRUCH SEQ lever switch to the up position.

10. Change the V AXIS PHASING lever switch on the Type R141A to the  $90^\circ$  position.

Change the BURST U lever switch to the down position. Adjust the A Phase control on the Type R520 PAL to align burst with the  $90^\circ$  position on the graticule.

The displayed burst vector now consists of only the V component. The burst V component amplitude can now be checked against the calibrated graticule V-axis scale mark (second mark out from center). Return the U lever switch to the up position.

11. Change the BURST V lever switch to the down position. Readjust the A Phase control on the Type R520 PAL as necessary to align burst with the  $180^\circ$  position on the graticule.

The burst U component amplitude can now be checked against the graticule U-axis scale mark (similar to Step 10). Return the V lever switch to the up position and the V AXIS PHASING switch to the  $90^\circ/270^\circ$  position. Set the Type R520 PAL A Phase control to re-align the burst vectors with their respective  $135^\circ$  and  $225^\circ$  graticule positions.

12. In the previous two steps, if the U and V amplitudes of the burst concur with the proper graticule scale mark, then the  $135^\circ$  and  $225^\circ$  burst vectors will be of proper amplitude (should indicate 75% level on the burst scale of the graticule) when both U and V components are present in burst. See Fig. 2-9.

## AVERAGE PICTURE LEVEL

When using the Type R141A with the FULL FIELD COLOUR BAR/MODULATED STAIRCASE selector in the VAR APL position, the AVERAGE PICTURE LEVEL switch sets the luminance level on three of each four active video lines. The true average picture level during a given field for various settings of the AVERAGE PICTURE LEVEL switch may be found in Table 2-2.

TABLE 2-2

<sup>1</sup> Indicated APL (%)	<sup>2</sup> 3-Line Luminance Level	<sup>1</sup> Indicated APL (%)	<sup>2</sup> 3-Line Luminance Level
12½	0	57½	60
20	10	65	70
27½	20	72½	80
35	30	80	90
42½	40	87½	100
50	50		

<sup>1</sup>Settings of the front-panel AVERAGE PICTURE LEVEL switch.

<sup>2</sup>Luminance level of three of each four active video lines.

For EBU colour bars, average picture level with the white reference at 100% amplitude is 41%. With the white reference set at 75% amplitude, average picture level is 37.5%. With the AMPLITUDE switch set to 100%, 0 SETUP, APL is 50%; in the 75%, 25% SETUP position, APL is 59%.

## Selecting Pal Pulse Output Characteristics

To select a square wave signal for output, the white-blue-brown lead on the Horiz Timing board is connected to pin connector B. To select a pulse output, the white-blue-brown lead must be connected to pin connector E. (See Fig. 2-11).

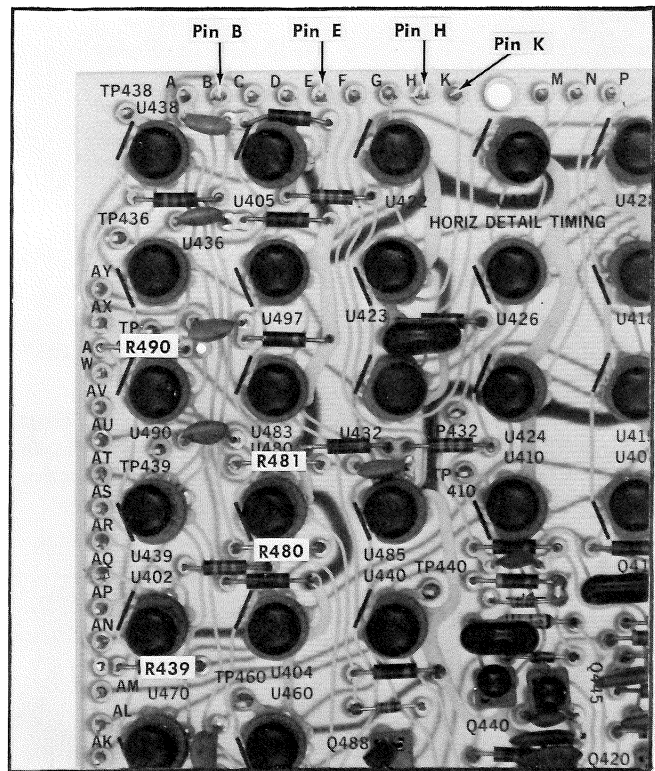

Fig. 2-11. Horiz Timing board showing locations of PAL PULSE selections, LINE DRIVE and FIELD DRIVE selections and setup level selections.

To start the PAL PULSE output signal coincident with lines at  $135^\circ$  phase, pin 7 of U480 is connected through R480 to pin connector B, and pin 5 of U480 is connected through R481 to C485 and thence to pin 5 of U485. Unless ordered otherwise, the instrument will be factory-wired in this manner. To start the PAL PULSE signal coincident with lines at  $225^\circ$  phase, the connections from pins 5 and 7 of U480 are reversed. This is accomplished by physically rotating the positions of R480 and R481 by  $90^\circ$ . The resistors are so placed that the connections will mechanically fit in either position. (See Fig. 2-11).

To select 4 V for PAL PULSE amplitude, R961 and R964 are connected in parallel in the emitter circuit of Q962 (Output Amps board). Parallel resistance is approximately 2 k $\Omega$ . To select 1 V for output amplitude, remove R961 (2.67 k), leaving R964 (7.96 k) in the emitter circuit of Q962. (See Fig. 2-12).

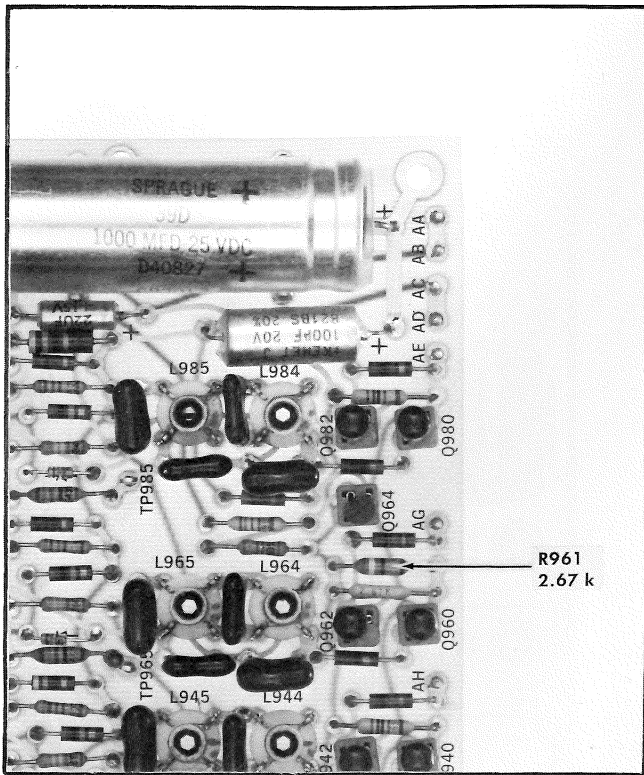

Fig. 2-12. Output Amps board showing location of PAL PULSE amplitude selection.

### Selecting LINE DRIVE Start

To select start of the LINE DRIVE Signal to coincide with the start of line sync, R490 is connected from pins 1 and 5 of U490 to pin 2 of U480 and the collector of Q450. The instrument is factory-wired in this manner unless ordered otherwise. To select start of LINE DRIVE to coincide with the start of line blanking, R490 is connected from pins 1 and 5 of U490 to ground. To accomplish this, replace R490 with a one-half watt resistor of the same value (10  $\Omega$ ). The longer resistor will now reach a board ground connection, which is located directly in line with the normal connection. (See Fig. 2-11).

### Selecting FIELD DRIVE Start

To select start of the FIELD DRIVE signal to coincide with the start of the first serrated pulse, pin 2 of U404A is connected through R439 to pin connector AT on the Horiz Drive board. The instrument is factory-wired in this manner unless ordered otherwise. To select start of the FIELD DRIVE signal to coincide with the start of the first equalizing pulse, pin 2 of U404A is connected through R439 to pin connector AX. This is accomplished by replacing R439 with a one-half watt resistor of the same value (10  $\Omega$ ). The longer resistor will now reach a board connection tying to pin connector AX. (See Fig. 2-11).

### Selecting Setup Level Duration

To select the setup level to terminate at the end of the blue colour bar, the white-brown-violet lead on the Horiz

Timing board is connected to pin connector K. The instrument is factory-wired in this manner unless ordered otherwise. To select the level to terminate at the end of black, connect the white-brown-violet lead to pin connector H. (See Fig. 2-11).

## GLOSSARY OF TERMS

**APL:** Average picture level. The average luminance level of the unblanked portion of a television line.

**BRUCH SEQUENCE:** An arrangement of colour burst signals which assures that the starting polarity of the burst signal is the same at the start of each field for improved stability of colour synchronization.

**CHROMINANCE:** Hue and saturation of a colour.

**COLOUR BAR:** A test signal, typically containing six basic colours—yellow, cyan, green, magenta, red and blue, which is used to check chrominance functions of colour TV systems.

**COLOUR BURST:** In PAL colour systems, this normally refers to a burst of approximately 10 cycles of 4.43361875 MHz subcarrier frequency on the back porch of the composite video signal. This serves as a colour synchronizing signal to establish a frequency and phase reference for the chrominance signal.

**COLOUR SUBCARRIER:** In PAL colour systems, this is the carrier signal whose modulation sidebands are added to the monochrome signals to convey colour information, i.e. 4.43361875 MHz.

**COMPOSITE VIDEO SIGNAL:** For colour, this consists of blanking, field and line synchronizing signals, colour synchronizing signals and chrominance and luminance picture information. These are all combined to form the complete colour video signal.

**HUE:** The attribute of colour perception that determines whether the colour is red, yellow green, blue, or the like. White, black and gray are not considered hues.

**LUMINANCE:** The amount of light intensity, which is perceived by the eye as brightness.

**PAL:** Phase alternation line. A system in which the subcarrier derived from the burst signal is switched 180° in phase from one line to the next. This system helps to minimize hue errors which may occur in a colour transmission.

**SATURATION:** The degree to which a colour is pure and undiluted by white light, distinguished between vivid and weak shades of the same hue. The less white light in a given colour, the greater is its saturation.

**STAIRCASE:** A video test signal containing several steps at increasing luminance levels. The staircase signal is usually amplitude modulated by the subcarrier frequency and is useful for checking amplitude and phase linearities in video systems.

**VITS:** Vertical insertion test signal. A signal which may be included during the vertical blanking interval to permit on the air testing of video circuitry functions and adjustments.

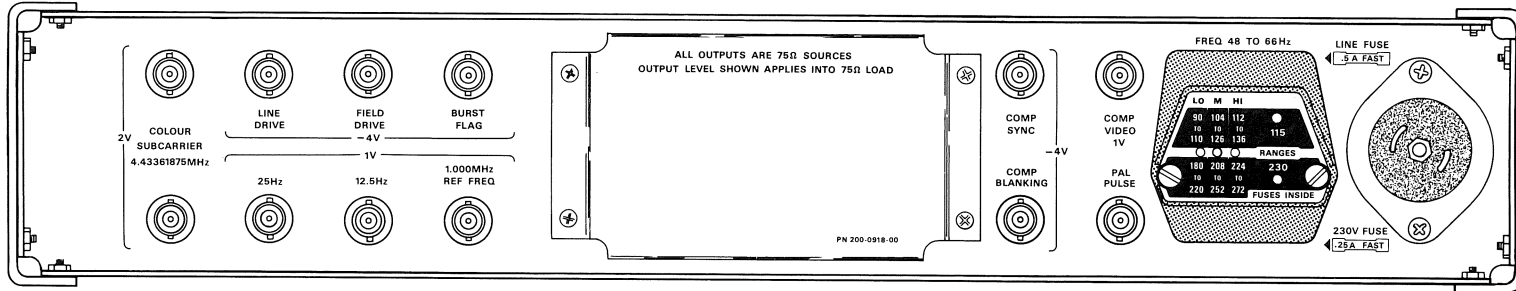
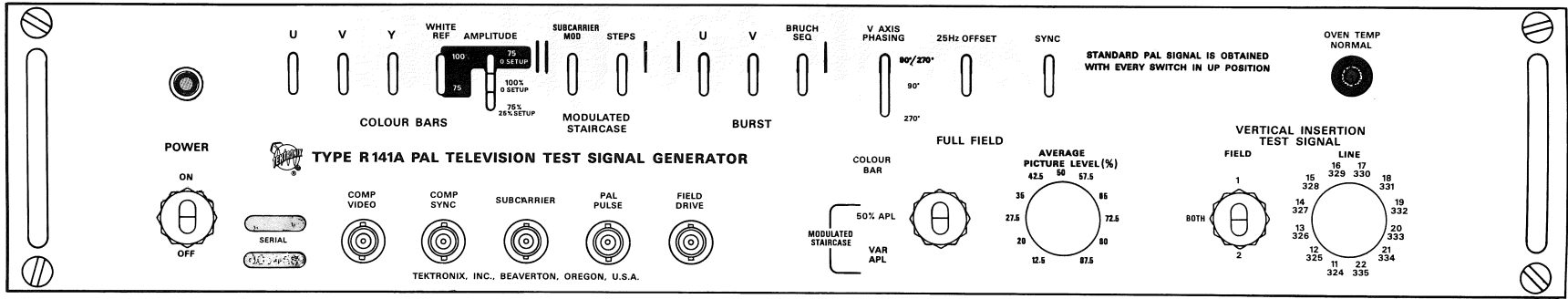

Fig. 2-13. Connectors and control setup chart.

# SECTION 3

## CIRCUIT DESCRIPTION

Change information, if any, affecting this section will be found at the rear of the manual.

### BLOCK DIAGRAM DESCRIPTION

#### Introduction

This section begins with a functional block diagram description. A complete block diagram (except for the Power Supply circuit) of the Type R141A is provided on a pullout page in Section 8.

Since this instrument uses numerous interconnections between stages to generate the composite video waveform, many of these interconnections must also be shown on the overall block diagram. To facilitate tracing the signal from one block to the next, the block diagram description that follows is keyed to the diagrams illustrated in Figs. 3-1 through 3-4. These illustrations divide the overall block diagram into four portions as follows:

1. Block diagram showing the stages that are required for generating the subcarrier, 12.5 Hz, 25 Hz and 1 MHz output signals.
2. Block diagram that shows the additional blocks required for generating the composite sync and vertical blanking signals.
3. Block diagram showing the additional blocks needed to generate the staircase composite video signal.
4. Block diagram showing the additional blocks required for generating the colour bar composite video signal.

#### Generating the Subcarrier, 12.5 Hz, 25 Hz and Vertical Blanking Signals (See Fig. 3-1)

The Subcarrier Oscillator is the master oscillator for generating the 4.43361875 MHz subcarrier frequency. This signal is applied to the Level Controlled Output Amplifier. This amplifier serves two main purposes: (1) isolates the oscillator stage and (2) maintains constant output level. Control of the output level is necessary for supplying a constant amplitude signal to the internal circuits of the Type R141 and to the three subcarrier output connectors (J36, J37 and J39) under various load conditions resulting from the number of loads that may be connected to the output connectors.

One circuit driven by the subcarrier signal is the Phasing Type Lower Sideband Generator. The purpose of this circuit is to obtain a lower sideband frequency which is 25 Hz below 4.43361875 MHz. This is accomplished by shifting the subcarrier signal by 90° and by shifting the 25 Hz offset signal by 90°. (The 25 Hz offset signal originates from the Vertical Counter circuit. This offset signal can be turned off, if desired, by placing the SUBCARRIER 25 Hz OFFSET switch to the down position.) Combining these phase-shifted signals with the original reference sig-

nals produces a lower sideband frequency of 4.43359375 MHz. This frequency is exactly 25 Hz below the subcarrier frequency and is applied to the 4.43359375 MHz Amplifier and Filter circuit.

The 4.43359375 Filter removes the harmonic content from the signal. The signal is then applied to the Phase Lock Sampler circuit. This circuit compares the 4.43359375 MHz signal with a subharmonic of the 1 MHz signal originating from the 1 MHz Oscillator via the Horizontal Counter circuit. As a result of this comparison, the error signal is detected by the Amplifier Bandwidth Control and DC Control Loop circuits. These circuits apply the error signal to the 1 MHz Oscillator stage to maintain an exact ratio between the 1 MHz signal and the 4.43359375 MHz lower sideband frequency.

The signal from the 1 MHz Oscillator stage is applied through the 1 MHz Buffer Amplifier circuit to the 1.000 MHz REF FREQ rear panel connector. The 1 MHz signal available at this connector can be compared with a frequency standard as a check on the accuracy of the 4.43361875 MHz subcarrier frequency generated by the Master Oscillator in the Type R141A. The 1 MHz signal in the Type R141A is also applied to the Horizontal Counter. This circuit generates signals at the television horizontal line rate and other harmonically related signals.

Referring to Fig. 3-1, a 3906.25 Hz signal from the Horizontal Counter is applied to the Phase Lock Sampler for use in maintaining a constant relationship between the 4.43361875 MHz Master Oscillator output and the 1 MHz Oscillator output signals. The 0.5 H (31,250 Hz) signal from the Horizontal Counter is applied via the Horizontal Logic circuit to the Vertical Counter. The Vertical Counter circuit provides 25 Hz and 12.5 Hz signals to the following stages: 25 Hz Output Amplifier, 12.5 Hz Output Amplifier, and the 25 Hz Offset circuit. The first two stages named provide signals to their respective connectors. The 25 Hz Offset circuit, previously described, is used to obtain the lower sideband subcarrier frequency of 4.43359375 MHz which is harmonically related to 1 MHz.

#### Generating Composite Sync and Composite Blanking Signals (See Fig. 3-2)

The Horizontal Counter circuit converts the 1 MHz incoming signal into signals which are harmonically related to the television line rate. These signals are applied to the Composite Sync Logic, Horizontal Timing, and Horizontal Logic circuits. One form of the 0.5 H (31,250 Hz) signal is applied from the Horizontal Logic circuit to the Vertical Counter circuit. The integrated circuits in the Vertical Counter circuit divide the incoming signal into timing pulses that drive the Vertical Detail Logic circuit.

Circuit Description—Type 141A/R141A

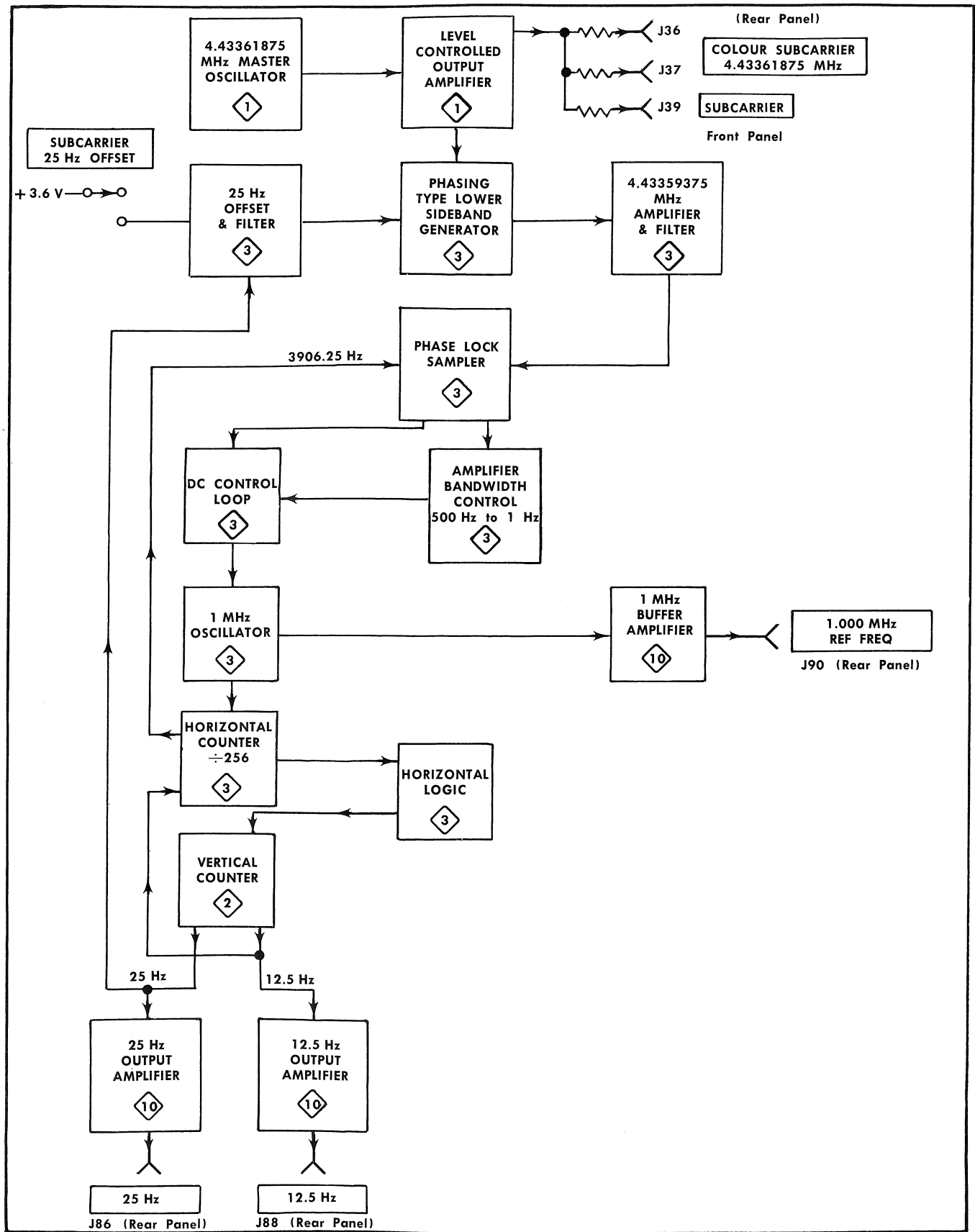
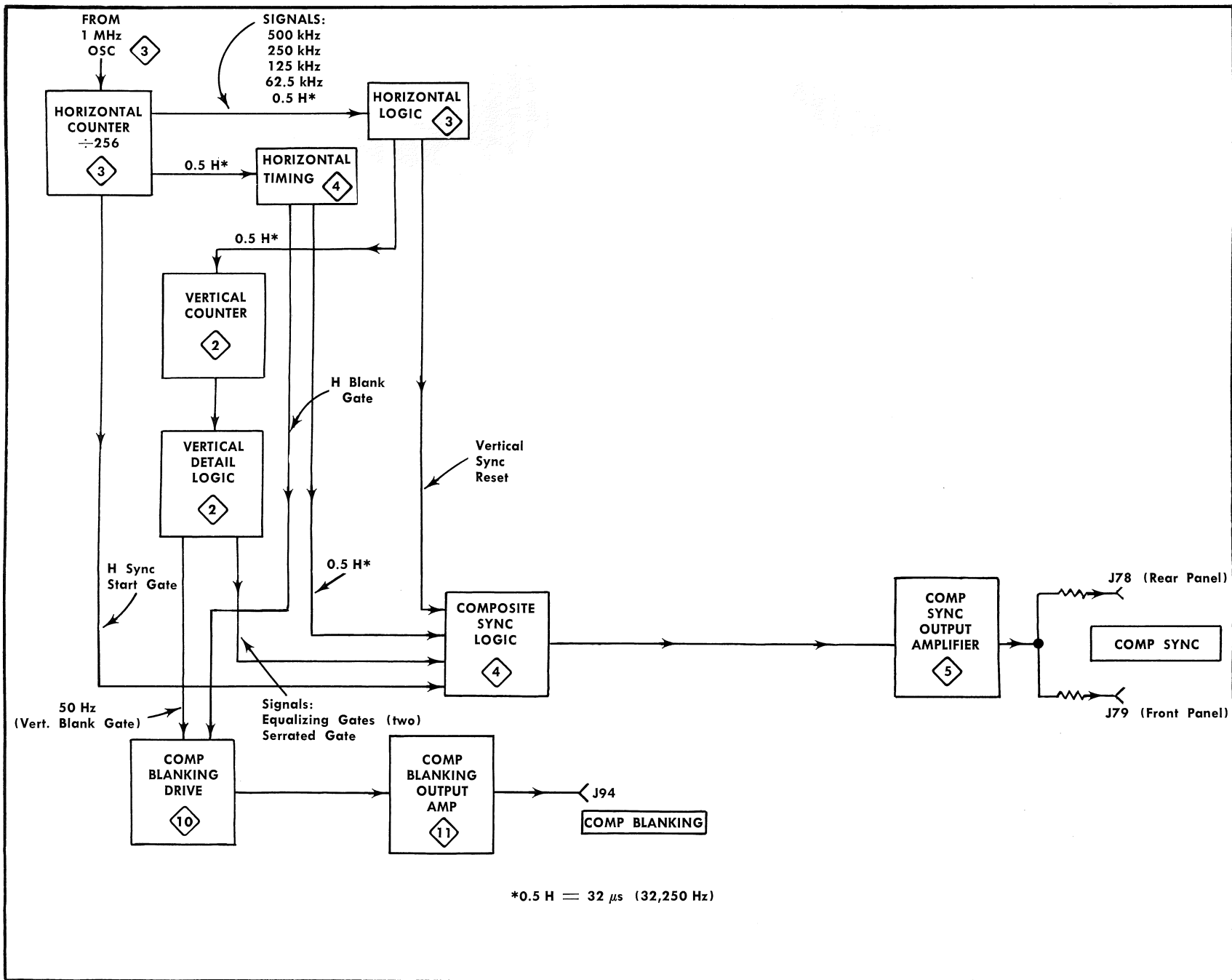

Fig. 3-1. Simplified block diagram showing the stages required for generating the subcarrier, 12.5 Hz, 25 Hz and 1 MHz outputs.



Fig. 3-2. Simplified block diagram showing how the composite sync and vertical blanking interval signals are generated.



## Circuit Description—Type 141A/R141A

The Vertical Detail Logic circuit, as the name implies, generates the various gates needed for producing the vertical blanking interval synchronizing pulses. Some of the signals (two equalizing gates and a serrated gate) are applied to the Composite Sync Logic circuit. The vertical blanking gate from the Vertical Detail Logic circuit and the horizontal blanking gate from the Horizontal Timing circuit are applied to the Comp Blanking Drive circuit and thence to the Comp Blanking Output Amp to make this signal available at the COMP BLANKING connector (J94) on the rear panel.

Three more input signals are applied to the Composite Sync Logic block (see Fig. 3-2). These are a 0.5 H signal from the Horizontal Timing circuit, the H Sync Start Gate from the Horizontal Counter and a vertical sync reset pulse from the Horizontal Logic circuit. These signals and all the other incoming signals applied to the Composite Sync Logic circuit are combined by the circuit to form the composite sync television signal.

The composite sync signal is applied to the Comp Sync Output Amp for amplification and then to the front- and rear-panel COMP SYNC connectors, J78 and J79, for use as a convenient output signal.

## Generating the Modulated Staircase Composite Video Signal (See Fig. 3-3)

### Composite Sync

Referring to the lower area of Fig. 3-3 block diagram, the composite sync portion of the video signal is applied from the Composite Sync Amplitude stage to the Luminance Driver circuit when the SYNC switch is set to the up position. If the switch is set to the down position, the input of the Comp Sync Amplitude stage is grounded, preventing the sync portion of the composite signal from reaching the Luminance Driver circuit.

## Generating the Luminance Steps

In describing the generation of the luminance portion (steps) of the staircase composite video signal, we begin with the COLOUR BAR/MODULATED STAIRCASE switch set to 50% APL and the MODULATED STAIRCASE STEPS switch set to the up position. The 50% APL switch position connects the vertical blanking gate from the Vertical Detail Logic circuit to the Staircase Line Drive stage. The VITS (VERTICAL INSERTION TEST SIGNAL) LINE and FIELD switches set the timing of the VITS gate to occur at the time set by the front-panel controls.

The vertical blanking and VITS gates are combined in the Staircase Line Drive circuit and then these gates are applied via the MODULATED STAIRCASE STEPS switch to the Staircase Luminance Amplitude stage. This stage converts the staircase timing gates from the Staircase Timing Logic circuit into a staircase luminance signal. Internal calibration controls are used to set the level of each step.

## Developing the Variable APL Signal

To develop the variable APL portion of the signal, the COLOUR BAR/MODULATED STAIRCASE switch must be set to the VAR APL position. Then the vertical blanking gate from the Vertical Detail Logic circuit is applied via the switch connections to the APL Timing Logic circuit. Incoming H pulses are combined with the vertical blanking gate to produce the APL timing gate present at the output of the APL Timing Logic circuit. These signals, along with the H blanking pulses, are applied to the APL Amplitude stage. The amplitude of the signal at the output of the APL Amplitude stage is determined by the setting of the APL switch. The variable APL signal is combined with the composite sync signal and applied to the Luminance Driver stage.

Signals consisting of the staircase luminance, APL and composite sync are combined in the Luminance Driver stage. This composite signal is applied to the Narrow Band Filter to minimize any harmonic frequencies that may adversely affect the chroma frequencies. From the Narrow Band Filter the signal is applied to the Luminance Output Amplifier where it is amplified for application to the COMP VIDEO output connectors (J50 and J52).

## Staircase Modulation

Vertical blanking and VITS gate signals are applied from the Staircase Line Drive stage via the up position of the MODULATED STAIRCASE SUBCARRIER MOD switch to the Staircase Chroma Amplitude stage. A Staircase chroma gate from the Staircase Timing Logic circuit is also applied to the Staircase Chroma Amplitude stage. At the output of this stage, the modulated gate for the staircase is applied to the +U and -U Filters. A burst signal from the Burst Amplitude stage is also coupled to the +U and -U Filters. These signals form the U component signal that is applied to the U Double Balanced Modulator.

The V component is generated in a similar manner and is applied from the +V and -V Filters to the V Double Balanced Modulator. Amplitude of the U modulation is adjusted by means of an internal control located in the Staircase Chroma Amplitude stage. If the COLOUR BAR/MODULATED STAIRCASE switch is set to the VAR APL position, an offset signal is applied from the APL Offset Chroma circuit to the +V and -V Filters.

## Generating Burst

The Burst Logic stage accepts the H burst gate, 0.5 H timing pulses and Bruch sequence keyout gate to develop the burst gating signal that is applied to the Burst Amplitude circuit. If the BURST BRUCH SEQ switch is set to the down position, the burst signals that are keyed out by the Bruch Sequence will now be keyed in by the equalizing gate. Peak-to-peak amplitude of the burst signal is set by the Burst Amplitude circuit to form part of the U and V components of the signal.

Phasing of the burst signal for PAL mode of operation is accomplished by means of the U-V Quad Phase and 0°-to-180° Phase Switcher circuits.

## Combining the Staircase Chrominance and Luminance Signals

Burst and staircase modulating signals are combined in the +V, -V, +U and -U Filters to form the chrominance signal. This signal is applied from the filters through the U and V Double Balanced Modulators to the Bandpass Filter. This filter has a center frequency response at 4.43 MHz to pass the chrominance signal. The chrominance signal is then applied to the Chroma Output Amplifier for application to the COMP VIDEO connectors, J50 and J52. At the connectors the chrominance signal is combined with the staircase luminance and composite sync components to form the modulated staircase composite video signal.

Note that separate output amplifiers are used: one for chrominance (Chroma Output Amplifier) and one for luminance (Luminance Output Amplifier). Separate amplifiers minimize differential phase and gain.

## Generating the Colour Bar Composite Video Signal (See Fig. 3-4)

### Composite Sync

This portion of the video signal is generated in the same manner as described in the preceding block diagram descriptions. The composite sync signal is then applied to the Luminance Output Amplifier stage as shown on the right hand portion of Fig. 3-4 block diagram.

## Generating the Luminance Portion of the Signal

The colour bar preset signal is applied from the Horizontal Logic stage to the Colour Bar Luminance Counter and Logic circuit and to the ÷4 Counter. Also from the Horizontal Logic stage a colour bar oscillator start signal is applied to the Colour Bar Oscillator Control circuit. This control circuit gates the 625 kHz Start/Stop Oscillator off during the interval between the end of the blue chroma colour bar and the start of the peak white bar. Purpose of the oscillator is to develop a signal that can be used as a controllable gate.

The 625-kHz pulses from the Start/Stop Oscillator are applied to the ÷4 Counter to obtain an output frequency of 156 kHz. This frequency corresponds to a pulse period of 6.5  $\mu$ s, which is the width of each colour bar segment or step. These pulses are applied to the Colour Bar Chroma Counter & Logic circuit via the Luminance Delay stage.

The 6.5  $\mu$ s pulses are delayed by the Luminance Delay stage to assure proper coincidence of the luminance steps and colour bar chrominance signal. The delayed 6.5- $\mu$ s pulses are applied from the Luminance Delay stage to the Colour Bar Luminance Counter & Logic circuit. This circuit generates the luminance gates for the green, red and blue components of the colour bar signal. The green, red and blue luminance gate signals are applied to the Colour Bar Luminance Amplitude stage. This stage converts the gate signals to the luminance amplitude components of the colour bar signal. The colour bar luminance amplitude signal is then applied to the Wide Band Filter to provide colour bar luminance amplitude steps that extend to the allowable bandwidth of the system.

From the Wide Band Filter, the luminance signal is applied to the Luminance Output Amplifier. Composite sync

is also applied to the Luminance Output Amplifier. Both of these signals are combined in this amplifier stage for use as an output signal at the COMP VIDEO connectors, J50 and J52.

## Generating Burst

Burst is generated in the same manner as described for Fig. 3-3 block diagram. Note that for both block diagrams (Figs. 3-3 and 3-4), the burst flag signal is applied to the Burst Flag Output Amplifier to make these signals available at the BURST FLAG connector J92.

## Colour Bar Modulation

The vertical blanking gate is applied from the Vertical Detail Logic circuit, via the COLOUR BAR position of the COLOUR BAR/MODULATED STAIRCASE switch to the Colour Bar Line Drive stage. This signal is applied through the up positions of the U and V COLOUR BAR switches to the Colour Bar Chroma Amplitude circuit.

The 6.5- $\mu$ s pulses from the ÷4 Counter are connected to the Colour Bar Chroma Counter and Logic circuit for conversion into related green, red and blue chroma gates. These gate signals are then applied to the Colour Bar Chroma Amplitude circuit. In this circuit the green, red and blue gates are combined to generate the colour bar amplitude portion of the chrominance signal. The vertical blanking gate serves to gate off the chrominance during vertical blanking interval.

## Combining the Colour Bar Chrominance and Luminance Signals

The colour bar amplitudes and burst amplitude (from Burst Amplitude circuit) signals are combined in the +V, -V, +U and -U Filters to compose the chrominance portion of the composite signal. The chrominance signal is applied from the filters to the U and V Double Balanced Modulators to generate the sidebands required for proper phasing of the colour bars relative to the subcarrier frequency. The colour bar and burst chrominance signals with their U and V components are applied to the Bandpass Filter. As mentioned earlier, this filter has a center frequency response of 4.43 MHz to pass the chrominance signal. This signal is applied to the Chroma Output Amplifier for amplification. At the output of this amplifier, the burst and colour bar chrominance signals are applied to the COMP VIDEO connectors, J50 and J52, where these signals are combined with the composite sync and colour bar luminance amplitude signals to form the colour bar composite video signal.

## INTEGRATED CIRCUITS<sup>3</sup>

Many of the functions within the Type R141A are performed through the use of integrated circuits in the form of micrologic units. Complexities of the television composite sync waveform require numerous counting and logic functions for development of the signal. Gating of chrominance and luminance signals and generation of the staircase and colour bar luminance signals are also accomplished by means of integrated circuitry.

<sup>3</sup>Digital Concepts, Tektronix, Inc., Beaverton, Oregon 1968, Part No. 062-1030-00.

Circuit Description—Type 141A/R141A

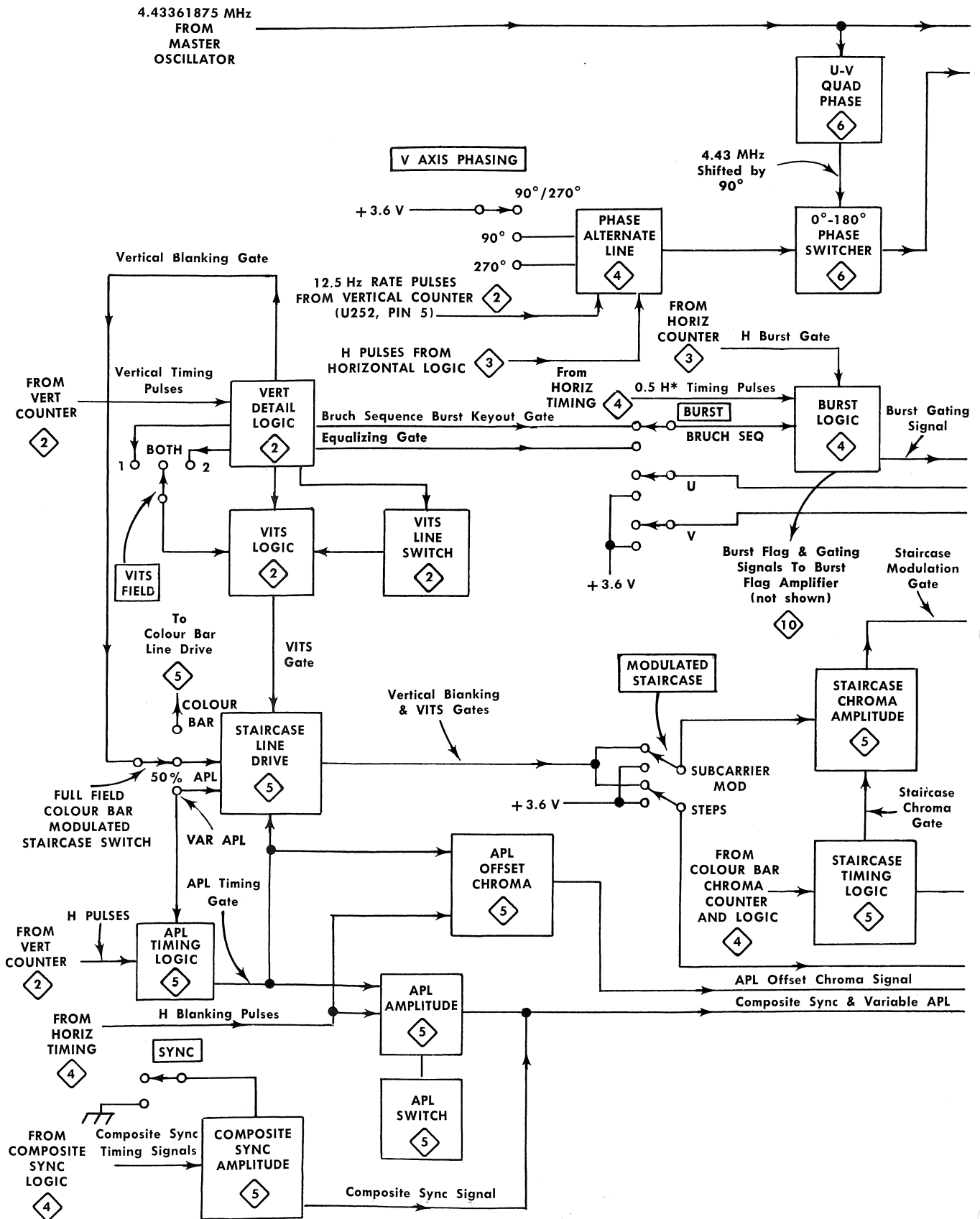
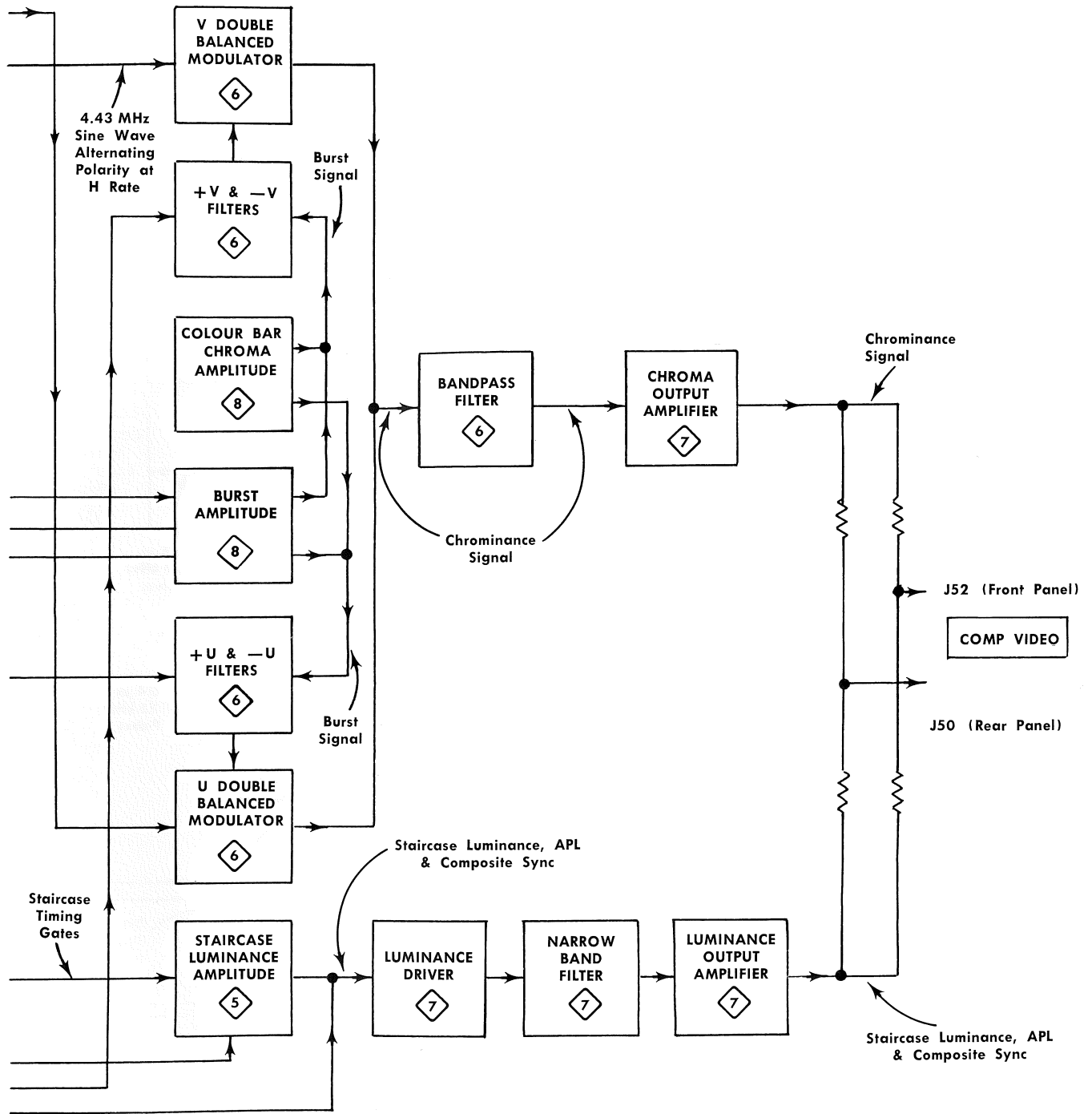

Fig. 3-3. Block diagram showing how the modulated staircase composite video signal is generated.



\*0.5 H = 32 $\mu$ s (31,250 Hz)

Fig. 3-3. Block diagram showing how the modulated staircase composite video signal is generated.

Circuit Description—Type 141A/R141A

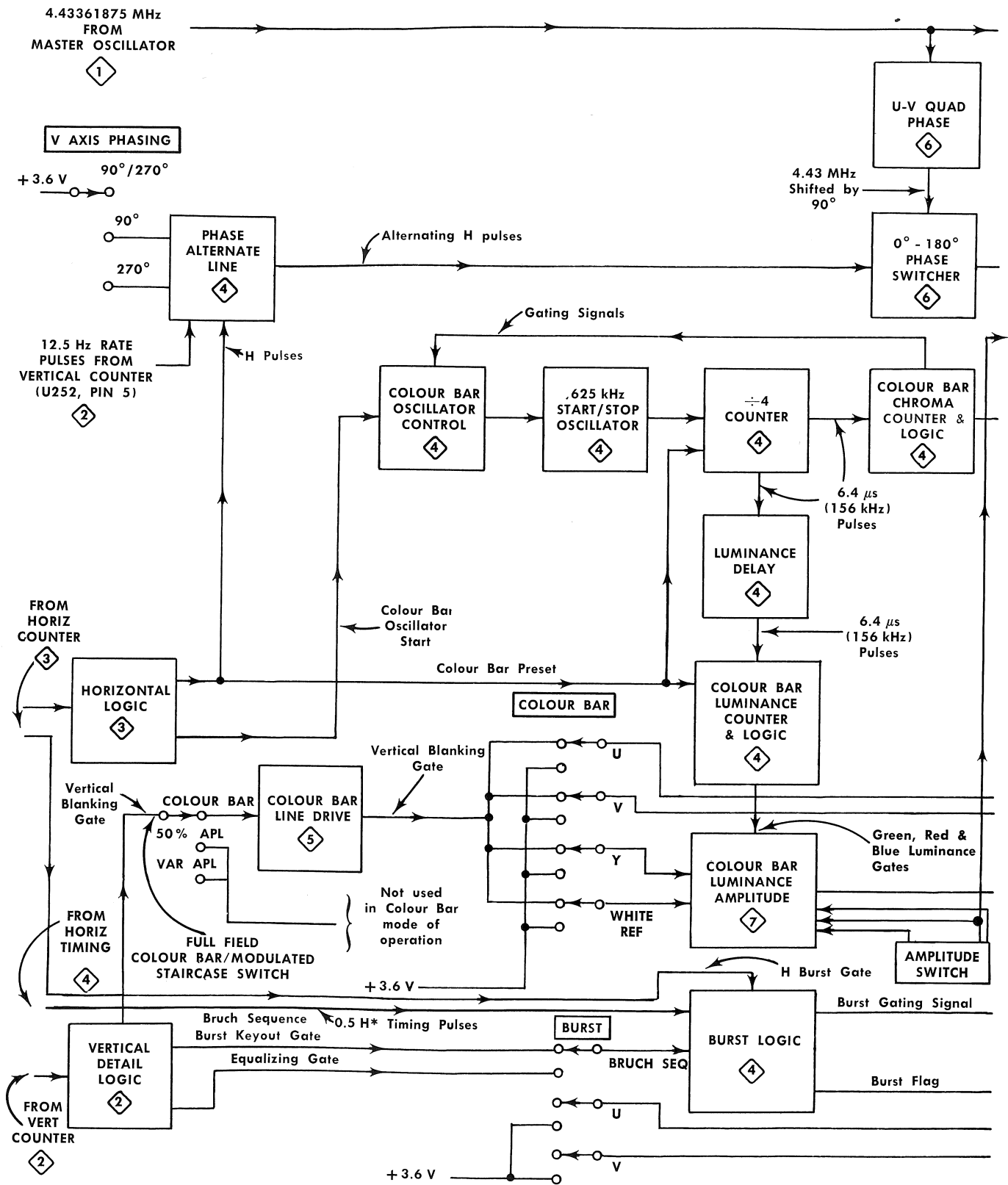

Fig. 3-4. Block diagram showing how the colour bar composite video signal is generated.



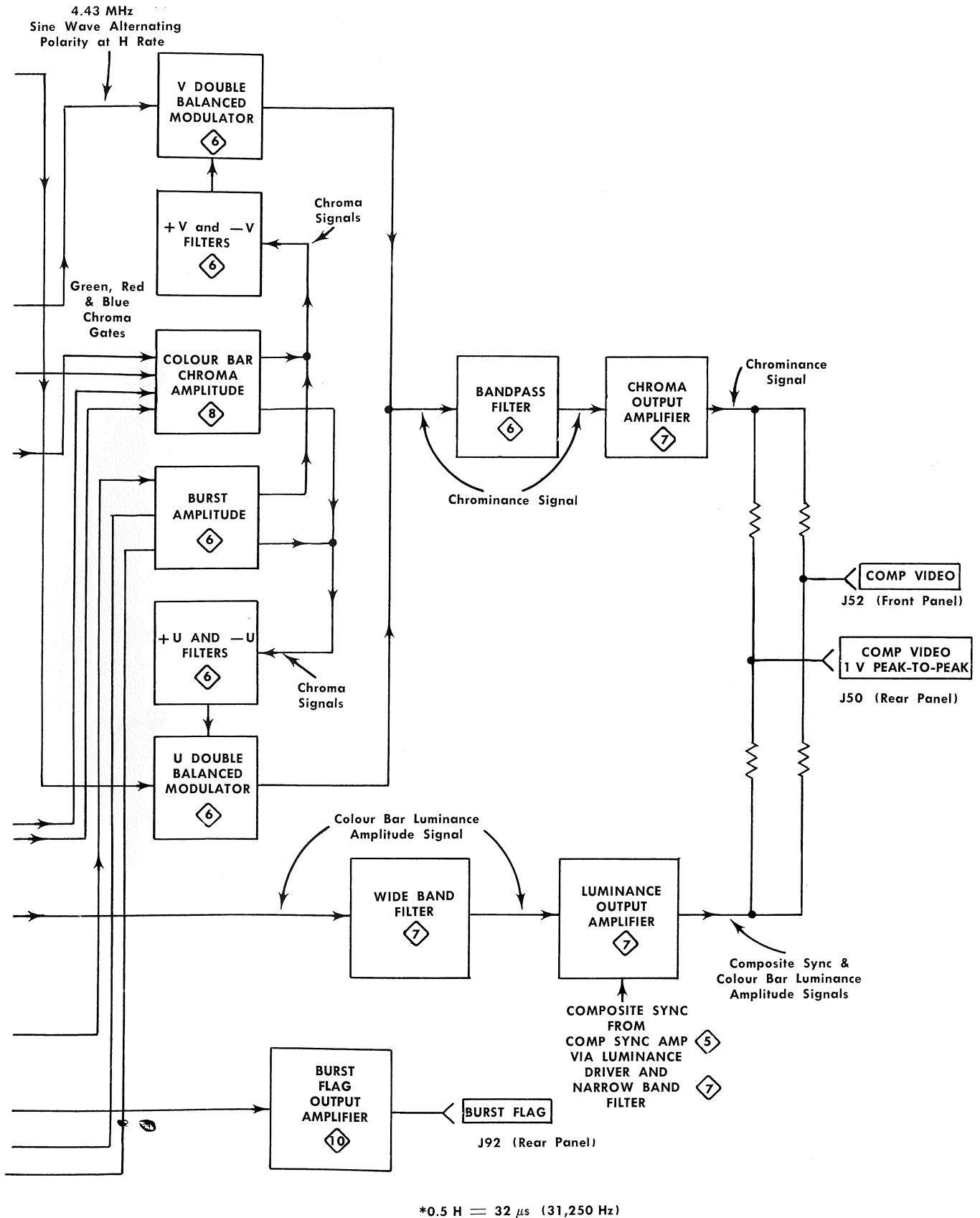
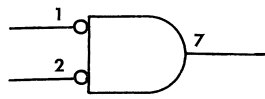
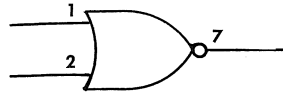

Fig. 3-4. Block diagram showing how the colour bar composite video signal is generated.

Circuit Description—Type 141A/R141A



(A) AND GATE  
( $\frac{1}{2}$  F $\mu$ L 914)



(B) OR GATE  
( $\frac{1}{2}$  F $\mu$ L 914)

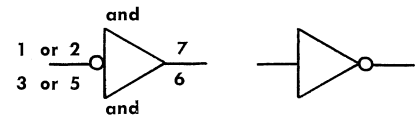

(C) Inverter or Buffer Stage  
(F $\mu$ L 900 or  $\frac{1}{2}$  F $\mu$ L 914)

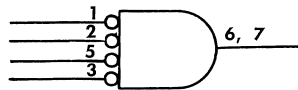

(D) 4-Input AND Gate

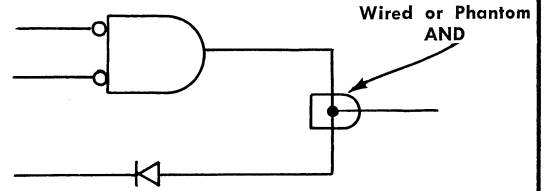

(E) Phantom AND Gate

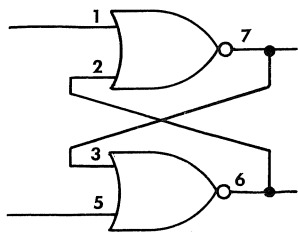

(F1) 2-Input Set-Clear Flip-Flop  
pin connections

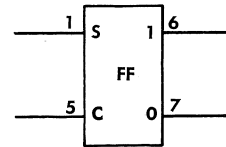

(F2) Schematic representation  
of 2-input set-clear flip-flop

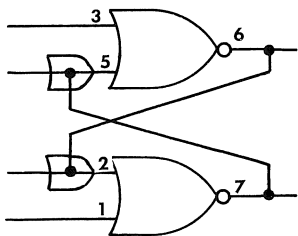

(G1) 4-Input Set-Clear Flip-Flop  
pin connections

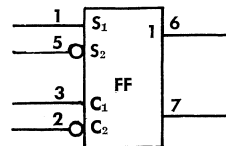

(G2) Schematic representation  
of 4-input set-clear flip flop

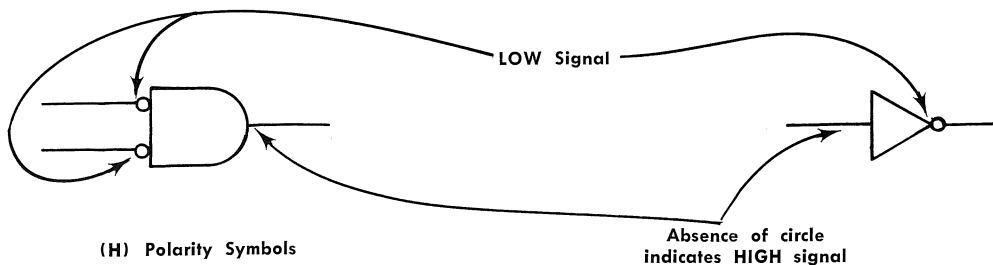

(H) Polarity Symbols

Absence of circle  
indicates HIGH signal

Fig. 3-5. Some of the Type F $\mu$ L 914 and Type F $\mu$ L 900 Micrologic symbols and configurations as used in Type 141A/R141A.

Knowledge of the internal workings of the various micrologic units is not necessary for an understanding of circuitry in the Type R141A, since the circuit description is concerned primarily with signal conditions at the input and output terminals of each unit.

Depending on external connections, several different functions may be performed by a single type of micrologic unit.

Rather than describe each unit's operation repeatedly throughout the circuit descriptions, each configuration will be explained here. The information in this portion can serve as reference material when studying the individual circuits.

Figs. 3-5 and 3-7 illustrate the various symbols which are used in this manual to designate micrologic units. A single unit may contain two or more sections which may be used separately. In these cases, one section will be labeled (A) and a second section will be labeled (B).

### Micrologic Unit Configurations

Several different functional capabilities are indicated in the various connection arrangements for Type F $\mu$ L 914 in Fig. 3-5.

The basic symbol for this unit is illustrated in Fig. 3-5 (A). Type F $\mu$ L 914 consists of two such units which may be used jointly or as completely separate circuit elements.

Fig. 3-5 (H) shows the symbol used in this manual to indicate that the desired input or output signals are "low". A small circle between the input or output terminal and the connecting lead indicates that the signal causing the desired reaction at that point will be a "low". The absence of a small circle adjoining a connecting lead to a terminal indicates that the proper signal at that point will be a "high".

A "high" indicates a more positive voltage level, while a "low" represents a less positive (or ground) level signal.

In the Type R141A schematics and circuit description, the level-indicating symbols are used in a manner known as POSITIVE LOGIC.

Fig. 3-5 (A) represents an AND gate, in which both inputs (pins 1 and 2) must be low to yield a high at the output (pin 7). Any other combination of inputs results in a low at the output. Table 3-1 is a truth table which shows the various combinations of signal levels for a two-input AND gate.

TABLE 3-1

Truth Table for 2-Input AND Gate

Input		Output
Pin 1	Pin 2	Pin 7
H	H	L
H	L	L
L	H	L
L	L	H

An OR gate is symbolized in Fig. 3-5 (B). The output of this OR gate will be low when pin 1, pin 2 or both pins 1 and 2 are high.

Fig. 3-5 (C) shows the symbols used for an inverter or buffer amplifier. The symbol with the circle at the input

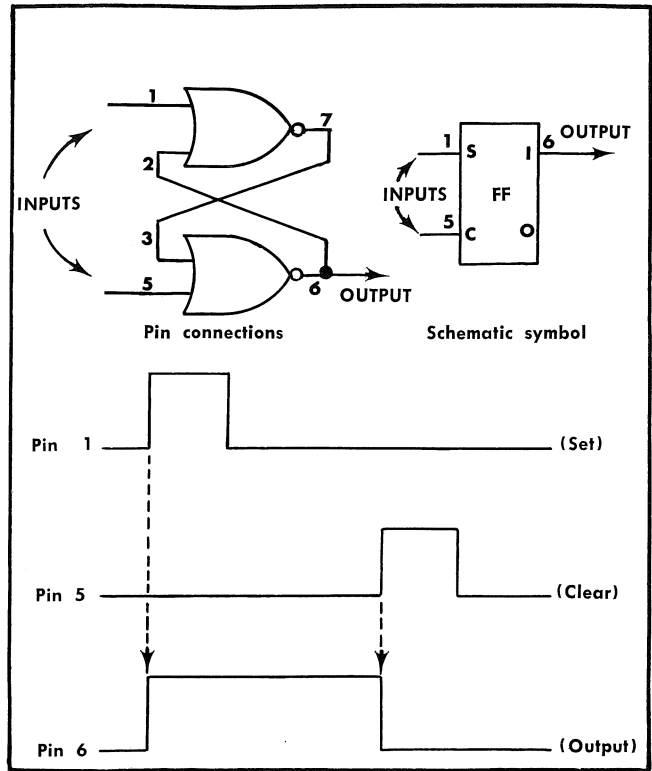

Fig. 3-6. Typical operation of a 2-input Set-Clear Flip-Flop.

pin indicates that the input signal will be a low and the output will be high. The circle at the output terminal, of course, indicates the opposite. The inverter stages are actually one-half of one of the two-input AND gates in a Type F $\mu$ L 914. The input is the base of a transistor and the output is the collector. The emitter is grounded.

A four-input AND gate is shown in Fig. 3-5 (D). The output pins of the two AND gates are connected together. All four input pins must be low to achieve a high at the output terminal (pins 6 and 7).

When the output terminals of two or more separate devices or signal sources are connected together, the junction of their connection forms a "phantom" AND or OR gate. This is indicated by a small AND or OR symbol around the junction. Fig. 3-5 (E) illustrates a phantom AND symbol. This means that all signals must be present at the junction to develop the desired signal.

A two-input Set-Clear Flip-Flop is symbolized in Fig. 3-5 (F<sub>1</sub> and F<sub>2</sub>). A description of a complete cycle of operation follows:

The Set-Clear Flip-Flop has two stable states. In one state, pin 7 will be high and pin 6 will be low. In the other state, the levels are interchanged. To begin the cycle, assume that at first pins 1 and 2 are low. Pin 7, and therefore pin 3, will be high. With either pin 3 or pin 5 high, pin 6 must be low. This is one stable state. To cause a change, a high is coupled to pin 1. Pin 7 must go to low, setting pin 3 to low. Assuming that pin 5 is also low, pin 6 (the output) will change to high. If pin 5 had been high due to a signal, the transition could not have occurred at that time.

### Circuit Description—Type 141A/R141A

Having changed to high on pin 6, the flip-flop will stay in this state until a high appears at pin 5. When this happens, pin 6 goes to low, pin 7 goes to high and the cycle is completed.

In typical operation, the desired output is a positive pulse (high). A high or positive signal at pin 1 starts the positive pulse output at pin 6. Later, a high at pin 5 terminates the positive pulse out. Time between highs at pin 1 and pin 5 determines the pulse width. Fig. 3-6 illustrates normal operation for the Set-Clear Flip-Flop.

A four-input RS Flip-Flop is illustrated in Fig. 3-5 ( $G_1$  and  $G_2$ ). The Burst Keyout Gate (U278) on the Vertical diagram is a good example of this configuration.

This stage consists of two controlled sections, cross-coupled, with one of the sections activated for Fields 1 and 4 and the other section activated for Fields 2 and 3.

At the start of Field 1, pins 1 and 2 are low, pin 7 and therefore pin 5 is high, pin 3 is low and pin 6 (the output) is low. To begin Burst Keyout Gate for Field 1, a high is coupled to pin 1. Pin 7 (and pin 5) goes to low, so pin 6 (and pin 2) goes to high. To end the positive pulse output, a low is coupled to pin 2. The high which started this cycle at pin 1 had already ceased, so pin 1 is low. Pin 7

(and pin 5) goes to high, thus pin 6 must return to low, ending the positive pulse output.

Pins 3 and 5 control the flip-flop in the same manner to generate the positive output pulses for Fields 2 and 3. Field Blanking Details II at the rear of the manual shows the relation of the input and output signals for U278.

Fig. 3-7 (A) shows the basic configuration when using the Type  $F_{\mu}L$  923 as a triggered divide-by-two counter. To flip, a negative-going transition is required at pin 2. The output pins (5 and 7) exchange polarity each time a negative-going transition arrives at pin 2. For example, the first negative-going transition at pin 2 may cause pin 5 to go low. The next negative-going transition sets pin 5 to high. Pin 5 will go to low every other trigger into pin 2, resulting in a divide-by-two countdown. When pin 5 is low, pin 7 is high and vice versa, similar to the two sides of a multivibrator.

In Fig. 3-7 (B), pin 6 is shown as an active element. This pin is typically used to preset the flip-flop so that the output pins start with the desired polarity at a certain time. When pin 6 is high, pin 5 will be high and pin 7 will be low. The high at pin 6 overrides any trigger input at pin 2 so that the flip-flop can always be started with the desired polarity. When the high is no longer present at pin 6, the unit can resume triggered operation under control of pin 2.

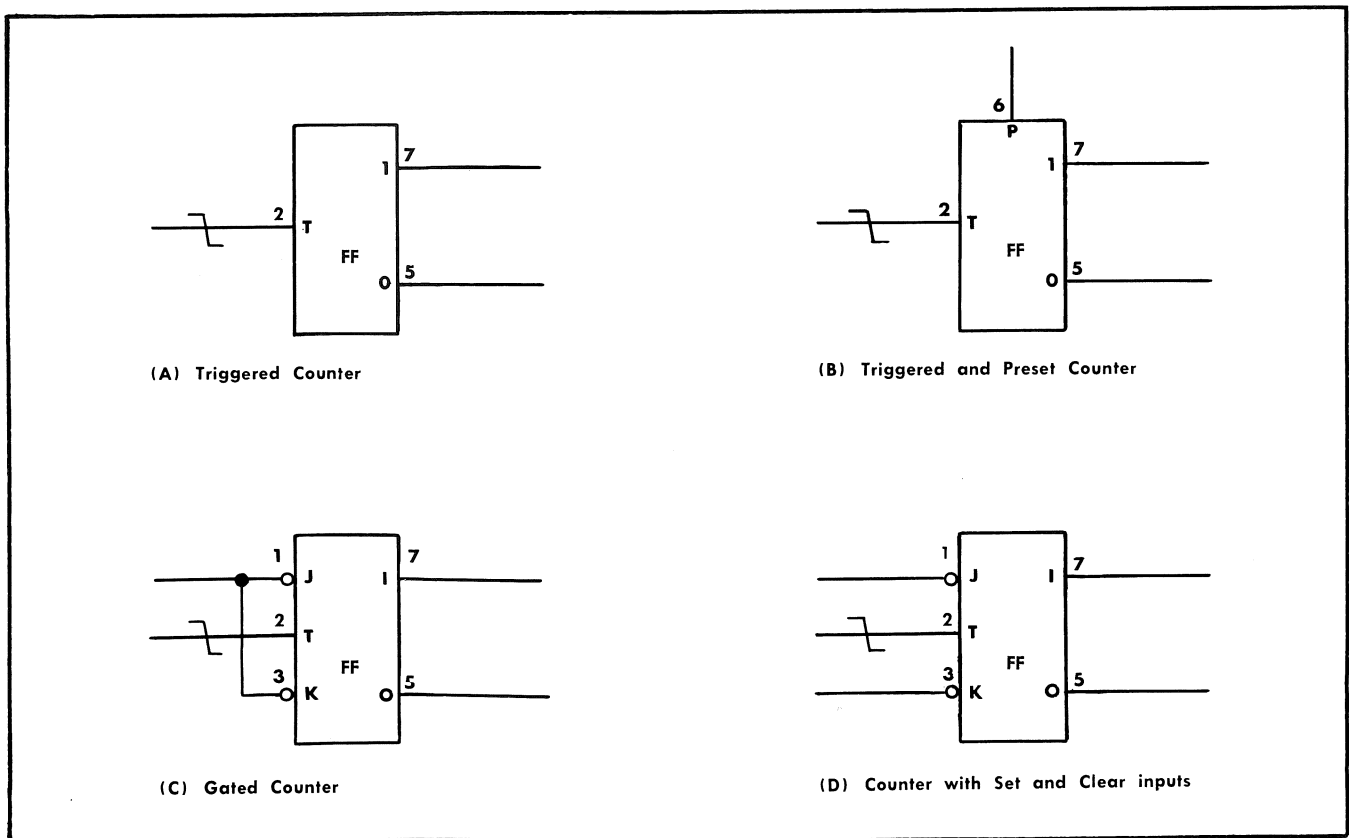

Fig. 3-7. Type  $F_{\mu}L$  923 micrologic symbols and configurations.

A gated counter is illustrated in Fig. 3-7 (C). In this configuration, operation is similar to the triggered counter except that the flip-flop is inhibited from changing states during the time that pins 1 and 3 are high. When pins 1 and 3 are low, negative-going transitions at pin 2 will trigger the flip-flop in the normal manner.

In Fig. 3-7 (D), separate controlling signals are coupled into pins 1, 2 and 3. As in the gated counter, if pins 1 and 3 are both high, pin 2 cannot trigger the flip-flop. If pin 1 is high and pin 3 is low, the next negative-going transition at pin 2 will trigger the flip-flop so that pin 7 is high and pin 5 is low. If the flip-flop is already in that state when the trigger arrives at pin 2, no change will occur. If pin 1 is low and pin 3 is high, the flip-flop will change states with a trigger at pin 2 as necessary to set pin 7 to low and pin 5 to high. Pin 7 output signal has the same polarity as pin 1 input signal and pin 5 output polarity will be the same as pin 3 input polarity.

When both pins 1 and 3 are low, the flip-flop will change states with each negative-going trigger at pin 2.

The preset input, pin 6, may be used in addition to the inputs at pins 1 and 3. A high coupled in to pin 6 will override any signals into pins 1, 2 and 3 and will preset pin 5 to high and pin 7 to low as previously described.

## SUBCARRIER OSCILLATOR AND OUTPUT

### Subcarrier Oscillator

The Subcarrier Oscillator (Master Oscillator) is a crystal controlled modified Colpitts oscillator with all critical components contained in a constant temperature oven. Close control of oven temperature provides a frequency stability of  $\pm 3$  Hz over an ambient temperature range of  $0^\circ$  to  $+55^\circ\text{C}$ .

The oscillator consists of Y105 and Q105, operating Class C. The crystal operates in its parallel resonant mode, with C105 acting as part of the electro-mechanical tank circuit of the crystal. C105 serves as a frequency adjustment when calibrating the oscillator against an external standard (see Calibration, Section 5).

### Level-Controlled Output Amplifier

The output signal from Q105, the subcarrier oscillator, is coupled to the emitter of Q115 through Q110, which serves as a buffer stage to isolate the oscillator from the driver.

Q115 is a grounded-base driver stage for T121. L118 suppresses any parasitic oscillation. The parallel LC network, C118 and L118 removes the harmonic distortion of the waveform which is caused by Class C operation of the subcarrier oscillator.

Q130 and Q135 are biased Class B to Class C and are alternately driven into conduction by the signal excursions across T121 secondary windings. C122 serves as an AC return path at the center-tap of T121. The collector circuit of Q130 and Q135 is tuned to resonance at the subcarrier frequency by C132.

The secondary windings of T131 supply drive to the front- and rear-panel output connectors and to the internal signal-generating circuits.

T131 secondary is also coupled via C128 to the peak-to-peak detector circuit consisting of CR124 and CR125.

During negative peaks, CR124 conducts through R124 and

R126 ( $-3.2\text{V}$  divider), thus applying a bias of  $-3.6\text{V}$  on C128. CR125 then conducts on positive peaks. Since the AC waveform is  $4\text{V}$  P-P, the voltage at the base of Q120 will be  $0\text{V}$ . (The  $-3.6\text{V}$  bias on C128 plus the  $4\text{V}$  P-P AC, minus the drop of CR125,  $0.4\text{V}$ , equals  $0\text{V}$ ). The emitter of Q120 is set at  $0.6\text{V}$  by CR120, thus setting the base switching point at  $0\text{V}$ .

Q120 is normally biased on by R125. The peak-to-peak detector output diverts the bias current from Q120, thus setting it at the proper point. Q120 has very high gain at the switching point ( $0\text{V}$ ). C126 lowers the AC impedance of the divider, R124 and R126. C125 filters the detector output.

Since Q120 is connected in series with the base circuits of Q130 and Q135, this sets their base voltages, determining at what point on the AC waveform conduction will commence and thus determining the magnitude of the AC current swing in the collector circuits and T131 primary windings.

If the load on T131 secondary changes due to adding or removing loads on the output connectors, the output amplitude will attempt to change. Suppose, for example, that the output load is increased by adding  $75\text{-ohm}$  terminations to the output jacks. The peak amplitude of the signal coupled through C128 will momentarily drop, resulting in less current through CR125 and thus a less positive voltage on the base of Q120. Conduction of Q120 increases and voltage drop across the transistor decreases, setting the bases of Q130 and Q135 at a more positive level. This increases the drive to T131 to compensate for greater loading and returns the output signal amplitude to its original level.

### Master Oscillator Oven

Oven temperature is sensed by a bridge network consisting of R142, R143, R144 and R145. R143 and R144 are not sensitive to temperature, while R142 and R145 are nickel resistive elements with a temperature coefficient of  $+0.55\%/^\circ\text{C}$ .

When the oven is cold, R145 is lower in resistance than R143, making the base of Q140B more negative than it is when the bridge is balanced. The collector of Q140B is therefore more positive. This more positive level is coupled to the base of Q150, which is an emitter-follower coupled to the base of Q155, the driver for the heating element (R155). The positive level on the base of Q155 causes heavy conduction through the heating element and thus rapid heating of the oven chamber.

As the oven approaches normal temperature, R145 increases in resistance, driving the base of Q140B in a positive direction. This results in a less positive level at the base of Q155, reducing the current through the heating element until a balance is achieved. Normal temperature is about  $+85^\circ\text{C}$ .

### Oven Temperature Lamp

Normal operating temperature for the oven is indicated by a front-panel lamp which glows when the oven is at the proper temperature. The lamp is extinguished when the oven is either below or above normal temperature.

When the instrument is first turned on and the oven is cold, R142 in the sensing bridge is lower in resistance than R144, and the base of Q140A is less negative than when the bridge is balanced. Q140A collector current is greater,

## Circuit Description—Type 141A/R141A

increasing the voltage drop across R161. This sets the voltages in the divider consisting of R161, R162, CR164 and R164 such that Q160 is cut off and CR162 is in conduction through R166. The resulting level at the base of Q165, the lamp driver, holds Q165 in cutoff. DS68, the indicator lamp in the collector circuit of Q165 is therefore off.

At normal temperature, R142 and R144 in the bridge are equal and the base of Q140A is more negative than when the oven was cold. Collector current of Q140A decreases, causing less voltage drop across R161. This biases CR162 cathode to a slightly positive voltage, thus allowing Q165 to go into saturation, turning the indicator lamp on.

If the oven temperature should happen to rise above normal, R142 will increase in resistance, making the base of Q140A more negative than normal. This decreases collector current through R161, causing the junction of R161 and R162 to become more positive. The base of Q160 is now more positive, bringing Q160 into conduction. The drop across R166 causes the base of Q164 to drop, cutting off the collector current through the indicator lamp, which then goes off.

## VERTICAL 2

Circuits on the Vertical board include the Vertical Counter, Vertical Detail Logic and VITS Logic.

A waveform chart labeled Field Blanking Details II is provided on a pullout page at the rear of the manual to show certain selected waveforms appearing at test points (TP) and pin connectors in proper time-relation to each other. Interconnecting broken lines between waveforms illustrate the state of controlling signals necessary to cause a desired change at a given test point or pin connector.

The blue dash lines indicate direct cause and effect. The dotted lines indicate the state of signals which are closely related to the actual input signals (such as the opposite output of a flip-flop). Where several interconnecting lines are run together to a point on a waveform, all of the signals at the indicated origin points must be in the state indicated to achieve the illustrated output (at the terminal point of the lines).

## Vertical Counter

The Vertical Counter consists of U212, U214, U216, U218, U220, U222, U224, U226, U228, U229, U230, U246, U250 and U252.

These stages are all Type  $F_{\mu}L$  923 JK Flip-Flop units (except U229) which are described under Integrated Circuits. U229 is a Type  $F_{\mu}L$  900 Buffer unit, also previously described.

The counter derives various timing signals from the 31,250 Hz signal at pin R. The output signal at pin 5 of U229 resets U212, U214, U216, U218, U226 and U228 so that an even harmonic relation exists between line and field signals.

## Vertical Detail Logic

The Vertical Detail Logic includes U215, U217, U219, U221, U248, U254, U256, U258, U260, U262, U264, U266, U268, U270, U272, U274, U276, U278, U280 and U282.

All stages of the Vertical Detail Logic are Type  $F_{\mu}L$  914 micrologic units, connected as buffers, multiple-input gates and flip-flops. Operation of the various configurations is explained under Integrated Circuits.

The logic circuit combines timing signals from the Vertical Counter to generate gating signals for the vertical blanking and sync detail, burst keyout and VITS.

## VITS Logic

The VITS Logic circuit consists of U240, U242 and U244. U240 and U242 are connected as a seven-input AND gate. U244 is a Set-Clear Flip-Flop. These configurations are discussed under Integrated Circuits.

The VITS LINE and FIELD selector switches are integral parts of the circuit, determining at what line in each field (during the vertical blanking interval) the VITS Gate signal will appear. With the FIELD selector set to BOTH, the VITS Gate signal will occur during all four fields of the PAL system signal.

## HORIZONTAL COLOUR LOCK 3

### Phasing Type Lower Sideband Generator, 25 Hz Offset Circuit and Filter

The Lower Sideband Generator consists of T351, modulating driver stages and 90° phase-shifting stages. See Fig. 3-8.

The generator is used to supply a frequency which bears a relationship to the line frequency. The lower sideband generated when modulating 4,433,618.75 Hz with 25 Hz is 4,433,593.75 Hz. With the line frequency at 15,625 Hz, the relation is 1135/4. The 25 Hz modulating signal is derived from the line rate.

A 25 Hz square wave signal from the Vertical Counter circuit drives the 25 Hz Filter, an operational amplifier<sup>1</sup> connected as a twin T filter with a Q of about 40. R313 tunes the filter to resonance. Time constants of the filter convert the input square wave to a 25 Hz sine wave with very little harmonic content.

The 25 Hz sine wave is coupled via C319 to the base of Q330, one of the Balanced Modulator stages, and also to another operational amplifier stage consisting of Q320 and Q322. This operational amplifier creates a 90° phase shift with respect to the input while maintaining the clean sinusoidal waveshape.  $Z_i$  is C317, C318 and R320. C317 and C318 are series-connected with opposing polarities to form a high-capacitance, non-polar coupling capacitor.  $Z_f$  for the stage is C323. R323 sets the DC bias of the stage. The phase-shifted sine wave output is coupled to the base of Q325.

<sup>1</sup>Operational Amplifiers and Their Applications, Tektronix, Inc., Beaverton, Oregon 1965, Part No. 070-0526-00.



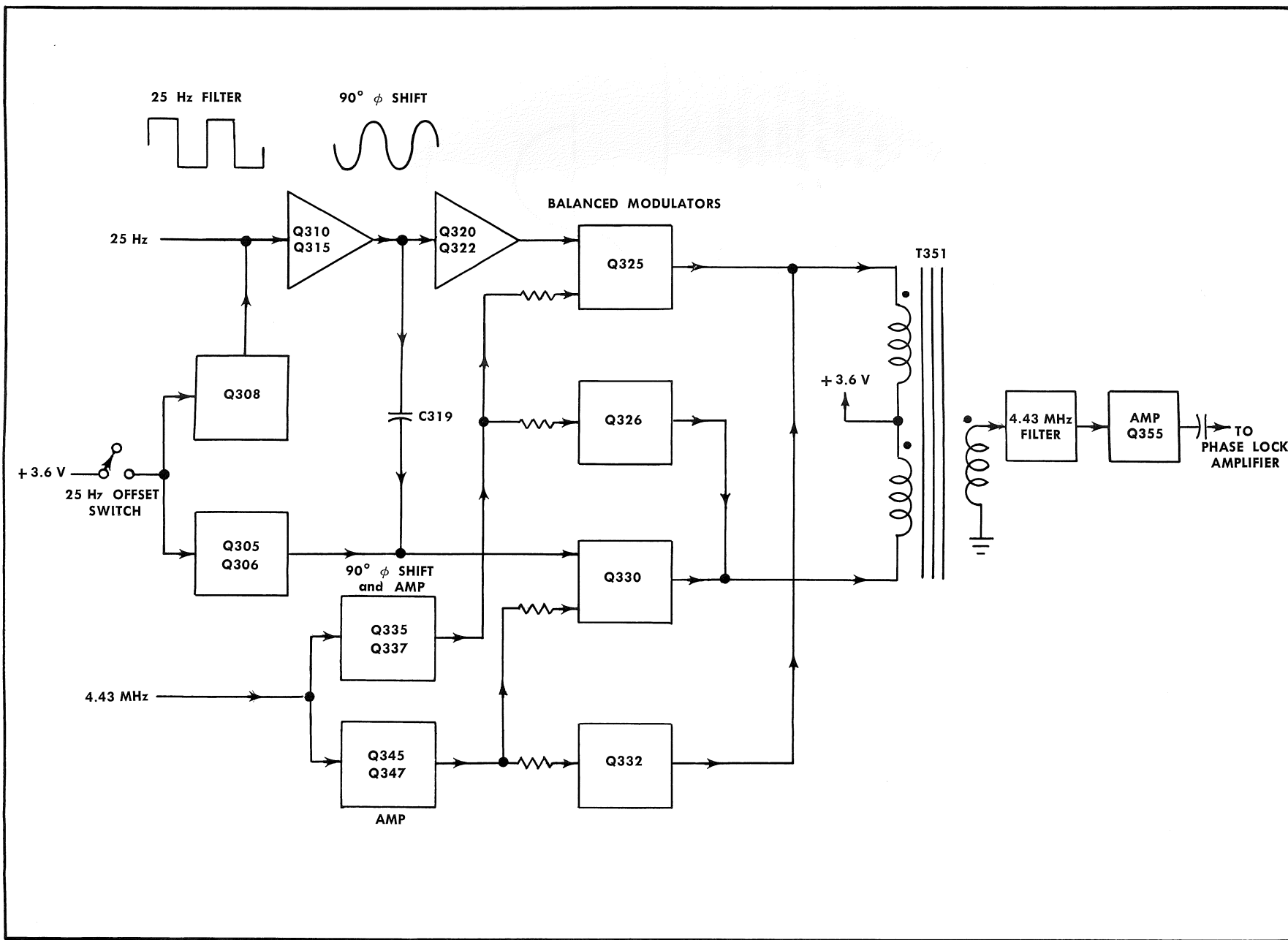

Fig. 3-8. Block diagram of Phasing Type Lower Sideband Generator.

## Circuit Description—Type 141A/R141A

When the front-panel 25 Hz OFFSET switch is placed in the down position, Q308, Q305 and Q306 are forward biased into saturation, effectively eliminating the 25 Hz modulating signal.

The subcarrier signal (4.43 MHz) is coupled to the base of Q345 and also through an LC network which shifts the phase by  $90^\circ$  to the base of Q335. The reference ( $0^\circ$  phase) signal from Q345 drives the emitters of Q330 and Q332. Q347 serves as a constant current source for Q345. The  $90^\circ$  phase-shifted signal from Q335 drives the emitters of Q325 and Q326. Q337 is the constant current source for Q335. Q335 and Q345 act as switches, providing a current square wave to their respective modulator pairs.

The 25 Hz reference and  $90^\circ$  phase-shifted signals are combined with the 4.43 MHz reference and  $90^\circ$  phase-shifted signals in the primary windings of T351 via the balanced outputs of Q325, Q326, Q330 and Q332. The resulting signal in the secondary of T351 is the lower sideband of the modulated subcarrier signal, or 25 Hz below 4.43361875 MHz (4.43359375 MHz) with the subcarrier suppressed.<sup>2</sup>

### Amplifier and Filter

A high-Q filter network consisting of C353, L354 and C354 removes the harmonic content of the signal. Q355 is an

<sup>2</sup>Frederick E. Terman, "Electronic and Radio Engineering," McGraw-Hill, New York, 4th Edition, 1955, pp. 539-544.

emitter-follower stage, coupling the signal to the Phase Lock Sampler.

### Phase Lock Sampler

The Phase Lock Sampler circuit consists of CR358, CR359, R358, R359, C358, C359 and T385. The circuit compares a modified signal from the subcarrier oscillator with a sub-harmonic of the 1 MHz oscillator. The resultant output is a DC voltage which is used to adjust the 1 MHz oscillator frequency to an exact ratio with respect to the subcarrier oscillator frequency.

The output signal at the emitter of Q355 is a sine wave at a frequency which is 25 Hz below the normal subcarrier frequency. The signal, coupled through C356, is insufficient in amplitude to turn on CR358 and CR359.

The output at pin 5 of U397 is square waves at a rate of 3906.25 Hz. This frequency, counted down from the 1 MHz oscillator, is a sub-harmonic of the signal appearing at the emitter of Q355. C386 and R386 differentiate the pulses from U397 into narrow spikes. The negative-going spikes turn on CR386 and appear at the emitter of Q385 as negative-going impulses which turn Q385 off rapidly. (Q385 is normally on.) The resulting collapse of the field in T385 primary causes a signal across T385 secondary which is of a polarity and amplitude to turn on CR358 and CR359.

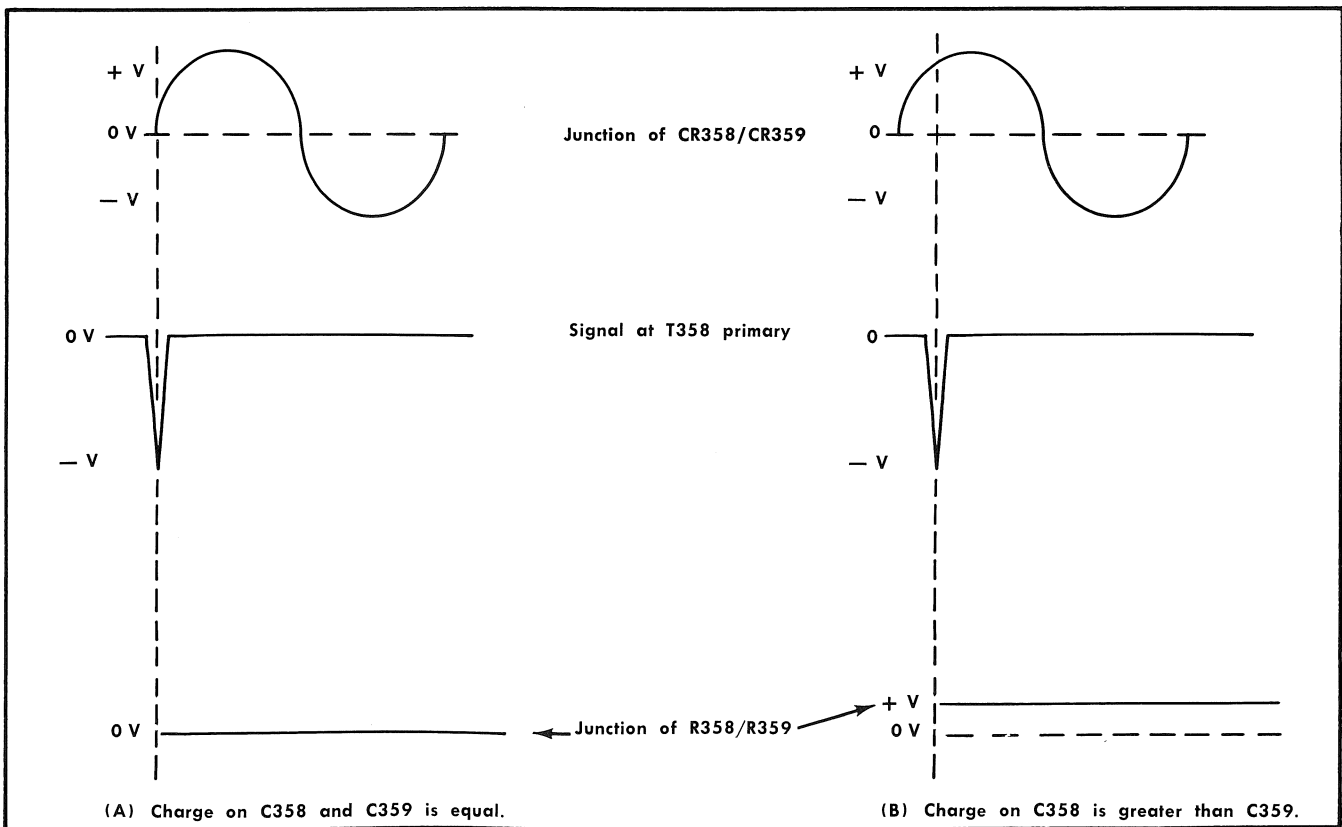

Fig. 3-9. (A) Action of Phase Lock Sampler at balance, and (B) when unbalanced. In example (B), frequency of the 1 MHz oscillator is too low and the level at the junction of R358 and R359 will cause the oscillator frequency to increase.

The signal induced in T385 secondary is very short in duration ( $\approx 50$  ns), causing CR358 and CR359 to be in conduction for a brief interval during the input cycle from Q355. This, in effect, samples the voltage reached by the input cycle at the instant that the impulse from T385 primary occurs.

If the input cycle from Q355 is passing through 0 volts at the instant of sample, CR358 and CR359 will conduct equally and thus charge C358 and C359 to equal levels.

These charges serve to hold CR358 and CR359 off during non-sample time. With equal charges on these capacitors, the net voltage at the junction of R358 and R359 will be 0 volts.

If the input cycle is at some positive point when sampled, CR358 will conduct more heavily than CR359, creating a larger charge on C358 than on C359. The unbalance in charges will result in a positive voltage level at the junction of R358 and R359 which is DC coupled through Q360A and Q366 to CR392. CR392 is a voltage-variable capacitor across

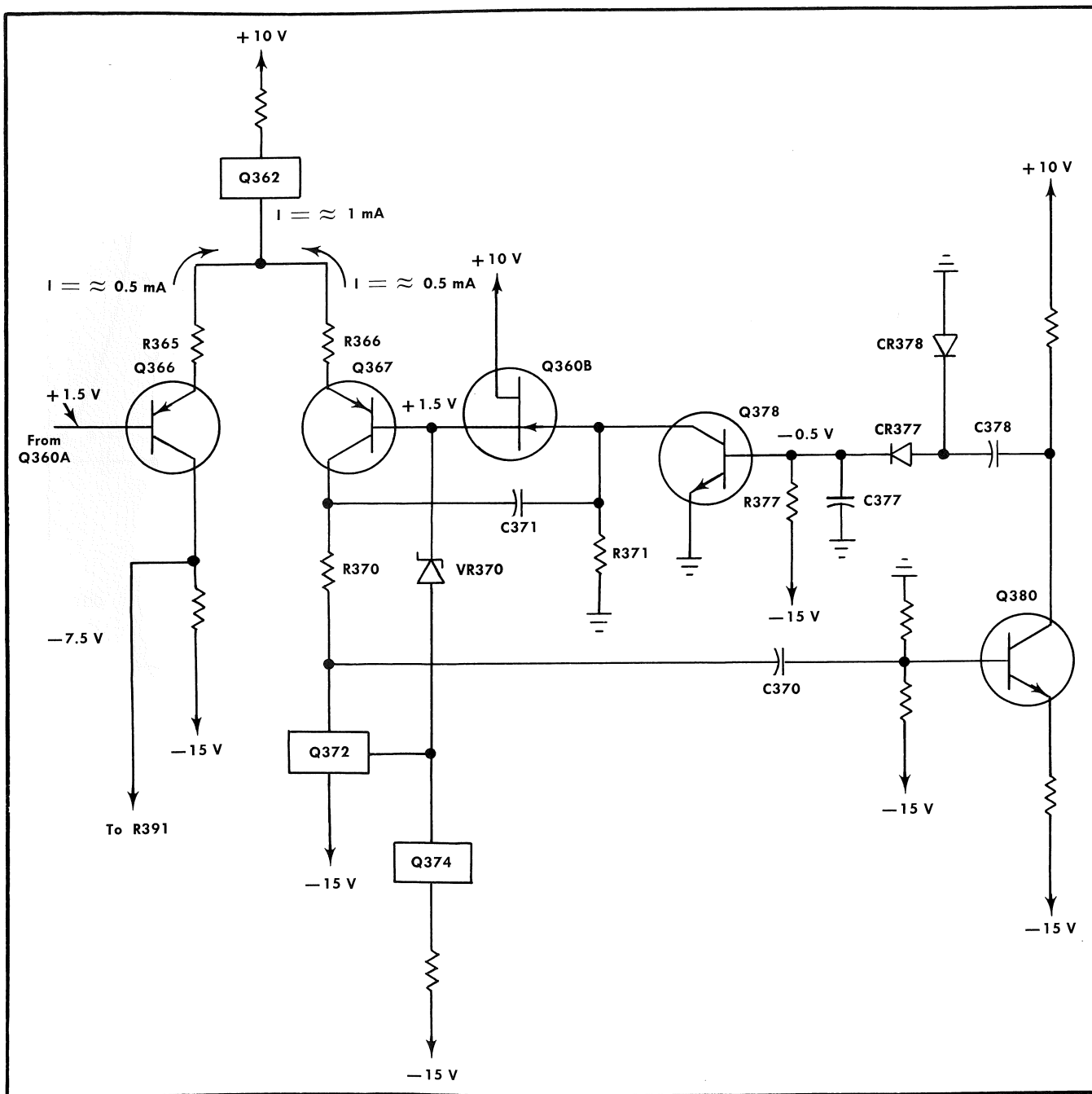

Fig. 3-10. Q366/Q372 comparator circuit and Amp Bandwidth Control circuit conditions when Phase Lock Sampler is balanced and 1 MHz Oscillator is at correct frequency.

### Circuit Description—Type 141A/R141A

the 1 MHz oscillator and so will change the oscillator frequency depending on the applied DC voltage. Fig. 3-9 illustrates the action of the Phase Lock Sampler stage.

### DC Control Loop Amplifier

The DC Control Loop Amplifier consists of Q360A, Q366, Q362, Q367, Q372, Q374 and Q360B. This circuit serves as a coupling between the Phase Lock Sampler and the voltage-variable capacitance, CR392.

A DC error signal is coupled from the junction of R358 and R359 in the Phase Lock Sampler to the gate of Q360A. The signal appears across R360 and the base of Q366. Q366 and Q367 are connected as a common constant-current emitter supply, Q362. Under quiescent conditions, when the subcarrier oscillator and the 1 MHz oscillator are locked in, Q366 and Q367 are balanced and bias on each is approximately the same. See Fig. 3-10.

Any DC error signal appearing at the base of Q366 is amplified, appearing on the collector of Q366, and is thence

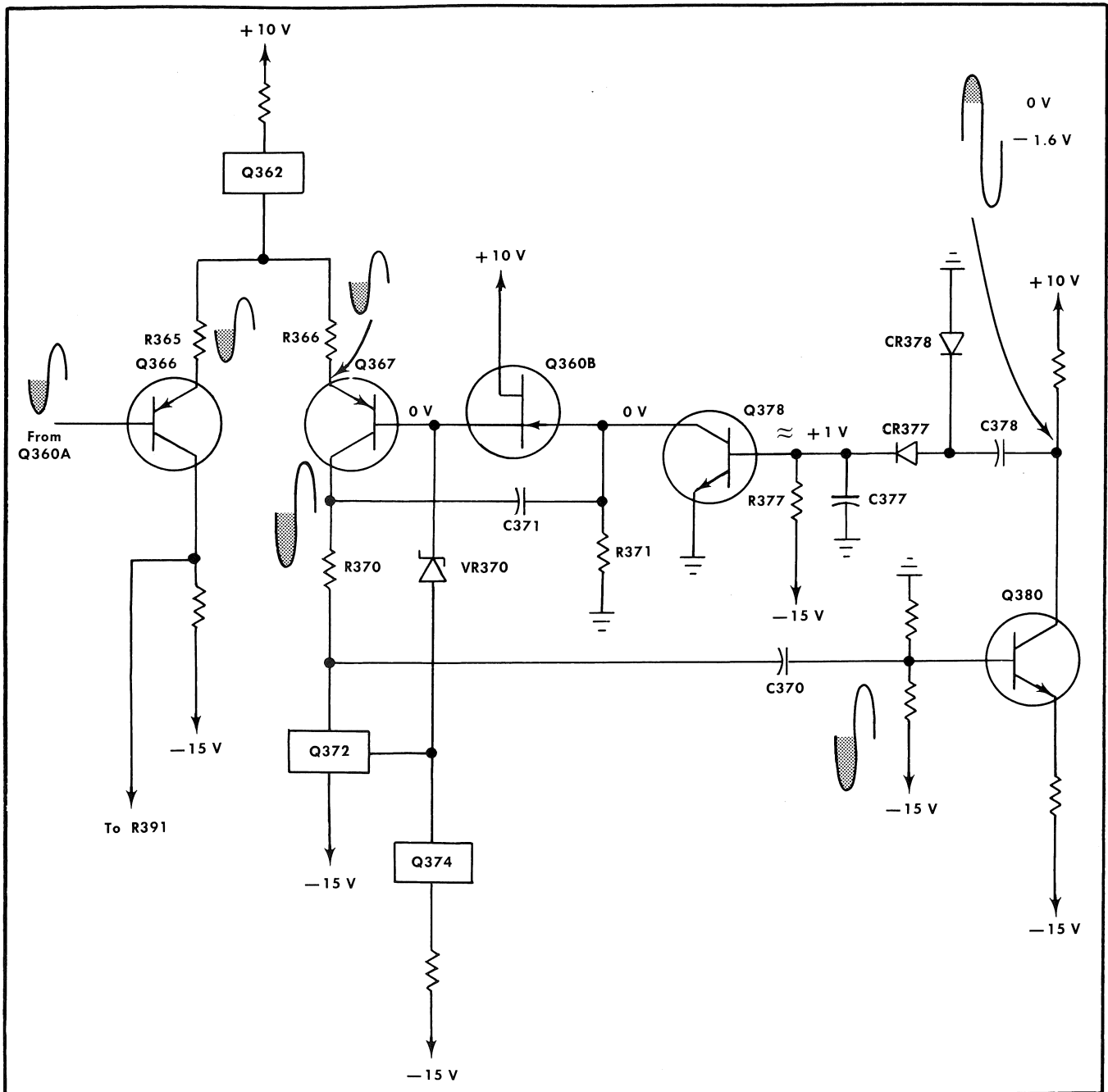

Fig. 3-11. Q366/Q367 comparator circuit and Amp Bandwidth Control circuit conditions when Phase Lock Sampler is not balanced and 1 MHz Oscillator is off frequency. Gain of Q366/Q367 comparator is at maximum. Q378 is in saturation.

coupled through R391 to CR392. The DC change across CR392 causes a change in capacitance across the 1 MHz crystal, resulting in a frequency change which is in opposition to the error signal originally occurring in the Phase Lock Sampler.

### Amplifier Bandwidth Control

The Amplifier Bandwidth Control circuit consists of Q378, Q380, CR377 and CR378. The purpose of this circuit is to limit the wideband AC gain of the DC Control Loop Amplifier for noise-level signals, and to increase the AC gain of the amplifier when the oscillator is off frequency. This increase in gain is to help in getting the oscillator to the proper frequency more rapidly.

When the instrument is first turned on and the subcarrier oscillator crystal oven is cold, the subcarrier frequency is lower than normal and thus the signal to the Phase Lock Sampler from the Lower Sideband Generator is lower in frequency than normal. Therefore, a large error signal will appear at the output of the Phase Lock Sampler. The signal will be somewhat sinusoidal in shape, since the point of sample will be different for each sample.

The large AC signal from the sampler will be coupled through Q360A to the base of Q366. The signal on the base of Q366 is emitter-coupled to the emitter of Q367 through R365 and R366. The signal is amplified and appears at the collector of Q367. From this collector, it is coupled through R370 and C370 to the base of Q380. The amplified AC signal at the collector of Q380 is coupled through C378 to a peak-to-peak detector consisting of CR377 and CR378.

The negative excursions are coupled through CR378 to ground. The positive peaks turn on CR377, causing current to flow up through R377 and putting a charge on C377 which forward biases the base of Q378. R377 and C377 act as a filter to prevent the AC signal from appearing at Q378 base. Q378 goes into saturation and its collector becomes essentially ground. This virtual ground is coupled via the gate-source of Q360B to the base of Q367. See Fig. 3-11.

With the base of Q367 held at ground, the signal which was previously coupled to the emitter of Q367 acts to aid the action of the other side of the comparator, Q366, thus giving the comparator circuit maximum AC gain.

Q374 provides a constant current for Q360B to prevent loading of Q360B's source. VR370 and Q372 act as a bootstrap to DC couple the signal at Q360B's source to R370.

When the 1 MHz Oscillator is at or very near the proper frequency, relatively low gain is desired for the comparator circuit to minimize the effects of noise or random signals.

The amplitude of these undesired signals will always be less than the amplitude of the Phase Lock Sampler error signal previously discussed. However, these lower amplitude signals will be coupled through Q367 to the base of Q380 as before. These signals will be amplified by Q380 but will not be large enough to bring Q378 into conduction. R371 is a high impedance, so the signal at Q367's collector is coupled through C371 to the gate of Q360B. The signal thus coupled to the gate of Q360B appears at Q360B source and Q367 base.

The signal at the base of Q367 is coupled through VR370 to the base of Q372. R370, in the collector circuit of Q372 acts as a bootstrap and appears as a much higher value ( $\approx 100 \text{ k}\Omega$ ) than normal. Any noise current through Q367 is then developed across this higher impedance, offering very little gain for the noise signal as seen at the emitter of Q367.

It can be seen, in following the signal through the circuit, that the signal at the base of Q367 will be in phase with the signal at the base of Q366. With the bases of both sides of the comparator being driven in phase, the resultant will be degeneration at the signal frequency. The comparator will therefore attenuate rather than amplify the undesired signal. See Fig. 3-12.

### 1 MHz Oscillator

The 1 MHz Oscillator, consisting of Y392, CR392, Q390 and Q395 is a modified Colpitts configuration. CR392 is used as a voltage-variable capacitor which alters the oscillator frequency in relation to the voltage applied from the Phase Lock Sampler circuit. A positive voltage level at the anode of CR392 increases the capacitance of the diode, lowering the frequency of the oscillator.

Q395 performs the dual functions of supplying the sustaining feedback to the oscillator circuit and serving as the output driving stage. Biasing is approximately Class B, with the collector output signal being a clipped sine wave.

Q395 collector signal triggers the Horizontal Counter and drives the output stages for the 1.000 MHz REF FREQ output.

### 1.000 MHz Output Amplifier

The 1.000 MHz Output Amplifier circuit consists of U580B and U590. These stages are located on the Staircase board. (See Diagram 10).

From the collector of Q395 and terminal T on the Horizontal Colour Lock board, the 1 MHz clipped sine wave signal is coupled to pin 2 on U580B. U580B is driven from cutoff to saturation by the input signal and thus has rectangular-shaped pulses as an output. These pulses drive U590, which is a buffer stage for driving the 1.000 MHz REF FREQ output.

### Horizontal Counter

The Horizontal Counter circuitry, consisting of U390 through U397, generates signals at the horizontal line rate and supplies other harmonically related signals to drive the micrologic units which comprise the Horizontal Logic stages. Also, the output of U397 drives the Phase Lock Sampler which maintains a constant relationship between the subcarrier oscillator and the 1 MHz Oscillator. Since the horizontal line rate is derived from the 1 MHz Oscillator, sync is also time-related to the subcarrier oscillator.

U390 through U397 are Fairchild Type  $F_{\mu}L$  923 JK Flip-Flop micrologic units connected as divide-by-two counters. See Integrated Circuits for a description of operation for this configuration.

### Circuit Description—Type 141A/R141A

With the exceptions of U395 and U396, pin 6 on each of the counters is grounded, corresponding to a low state. Each unit is therefore ready to change states upon receipt of a trigger at pin 2.

The first unit in the counter train (U390) is triggered by the 1 MHz oscillator. The output signal at pin 5 is negative-going pulses at a 500 kHz rate. The output signals of each succeeding unit are at a rate which is one-half the input rate. Fig. 3-13 illustrates the resulting output frequencies from each counter stage.

For U395 and U396, pin 6 on each is momentarily preset at intervals corresponding to  $V/2$  and  $V/4$  respectively, establishing a fixed relationship between the vertical and horizontal sync signals and consequently the subcarrier signal.

### Horizontal Logic

The output signals from U390 through U395 drive the Horizontal Logic stages, U380 through U383. These stages consist of Fairchild Type  $F_{\mu}L$  914 Micrologic Dual Two-input

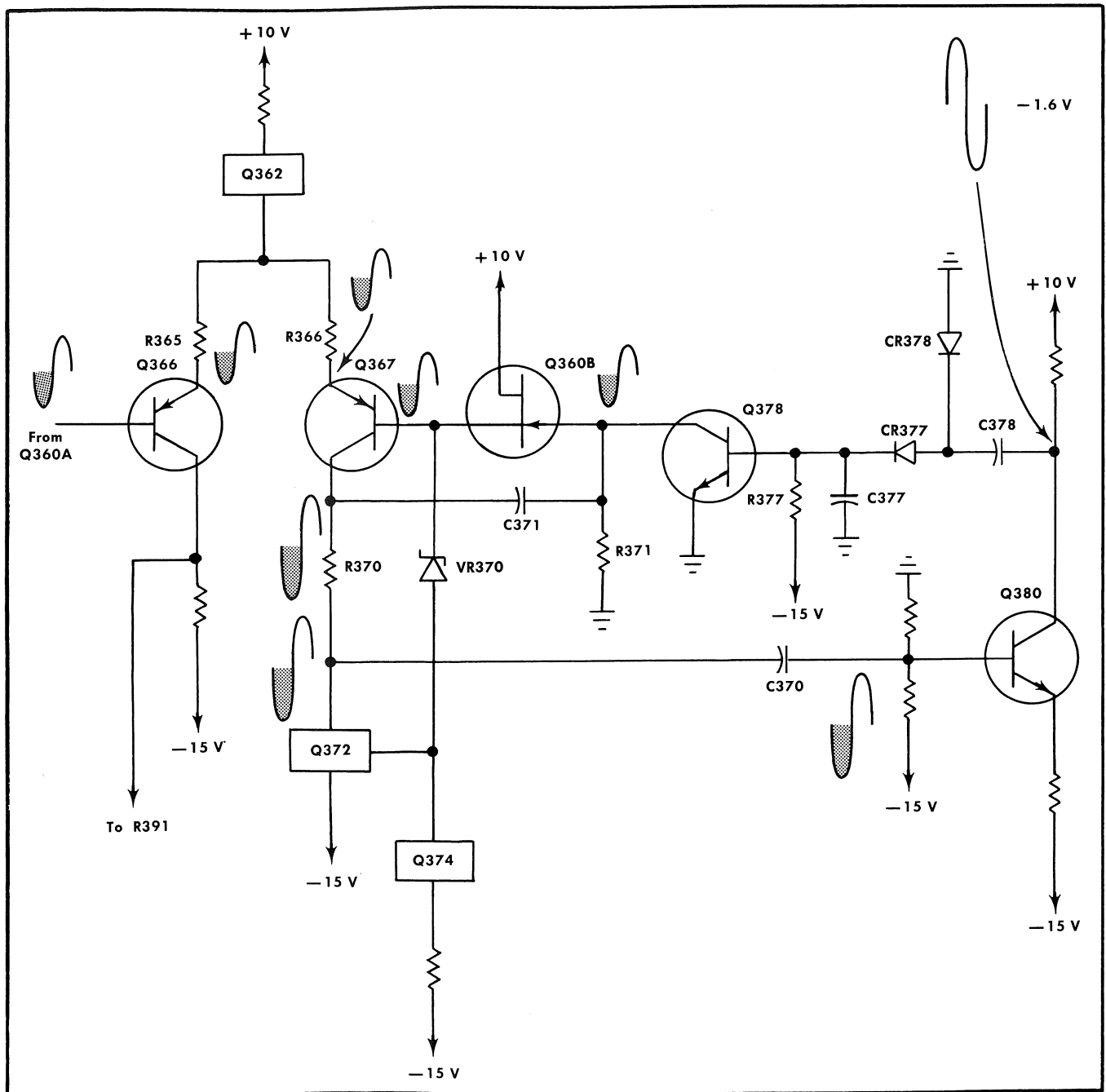

Fig. 3-12. Q366/Q367 comparator circuit and Amp Bandwidth Control circuit conditions when a noise-level signal appears at the base of Q366.



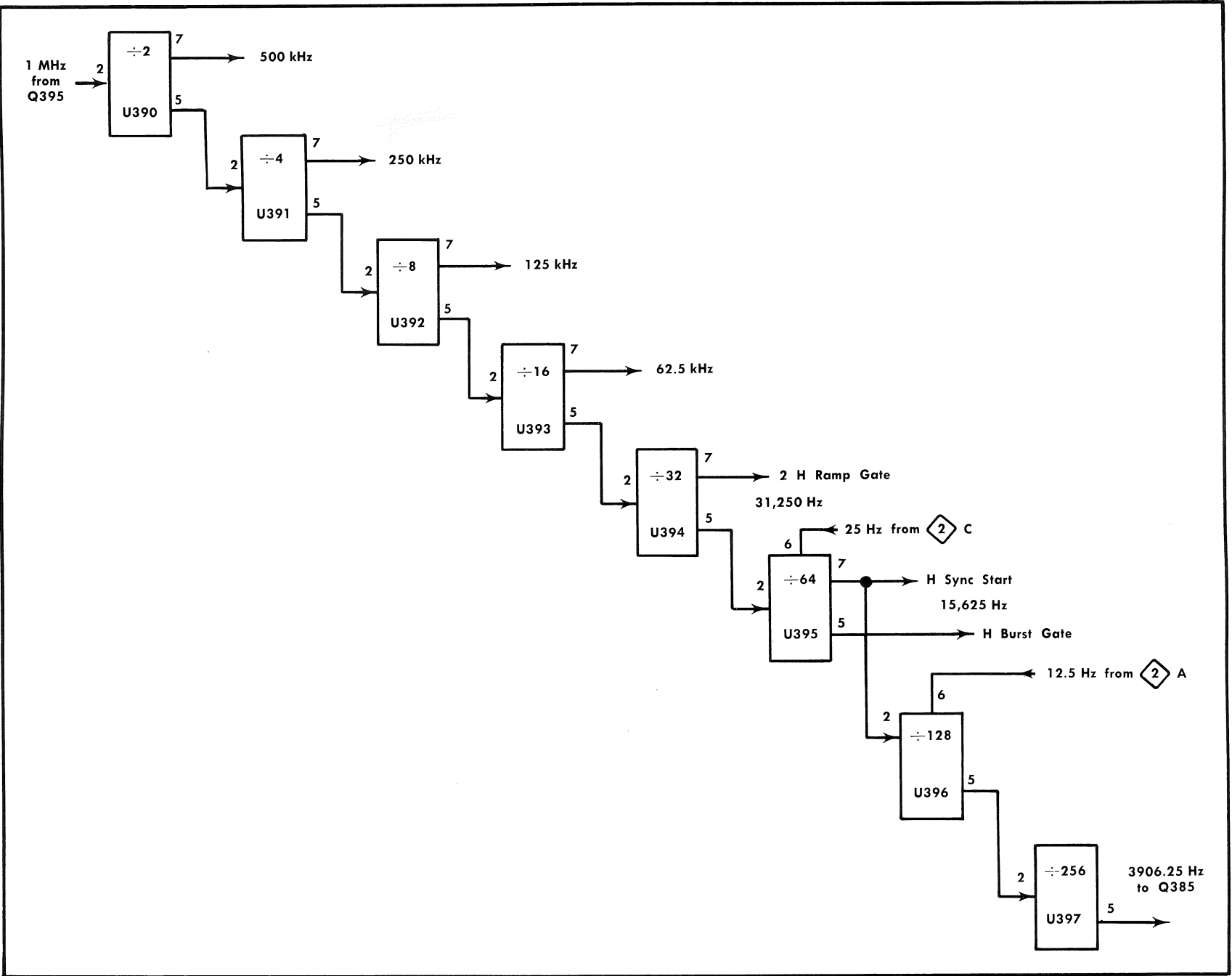

Fig. 3-13. Horizontal Counter, illustrating how 1 MHz oscillator is divided down to become horizontal line rate and how signals are derived to drive horizontal logic circuits.

### Circuit Description—Type 141A/R141A

Gate units. Each of the two-input sections are typically connected as an AND gate, requiring a low signal on both inputs to achieve an output signal which will be a high.

Two or more sections may be connected together to form multiple input gates. Fig. 3-14 is an example of signal conditions when both sections of a dual unit are connected to form a four-input AND gate. See Fig. 3-15 for input/output signals in the Horizontal Logic circuit stages.

### HORIZONTAL TIMING 4

#### Phase Alternate Line

The Phase Alternate Line circuit consists of U402 and U404B. U404B serves as an amplifier/inverter stage, driving the clock or trigger input (pin 2) on U402.

When the V AXIS PHASING switch is set to 90°/270°, U402 is a triggered flip-flop with the output pins (5 and 7)

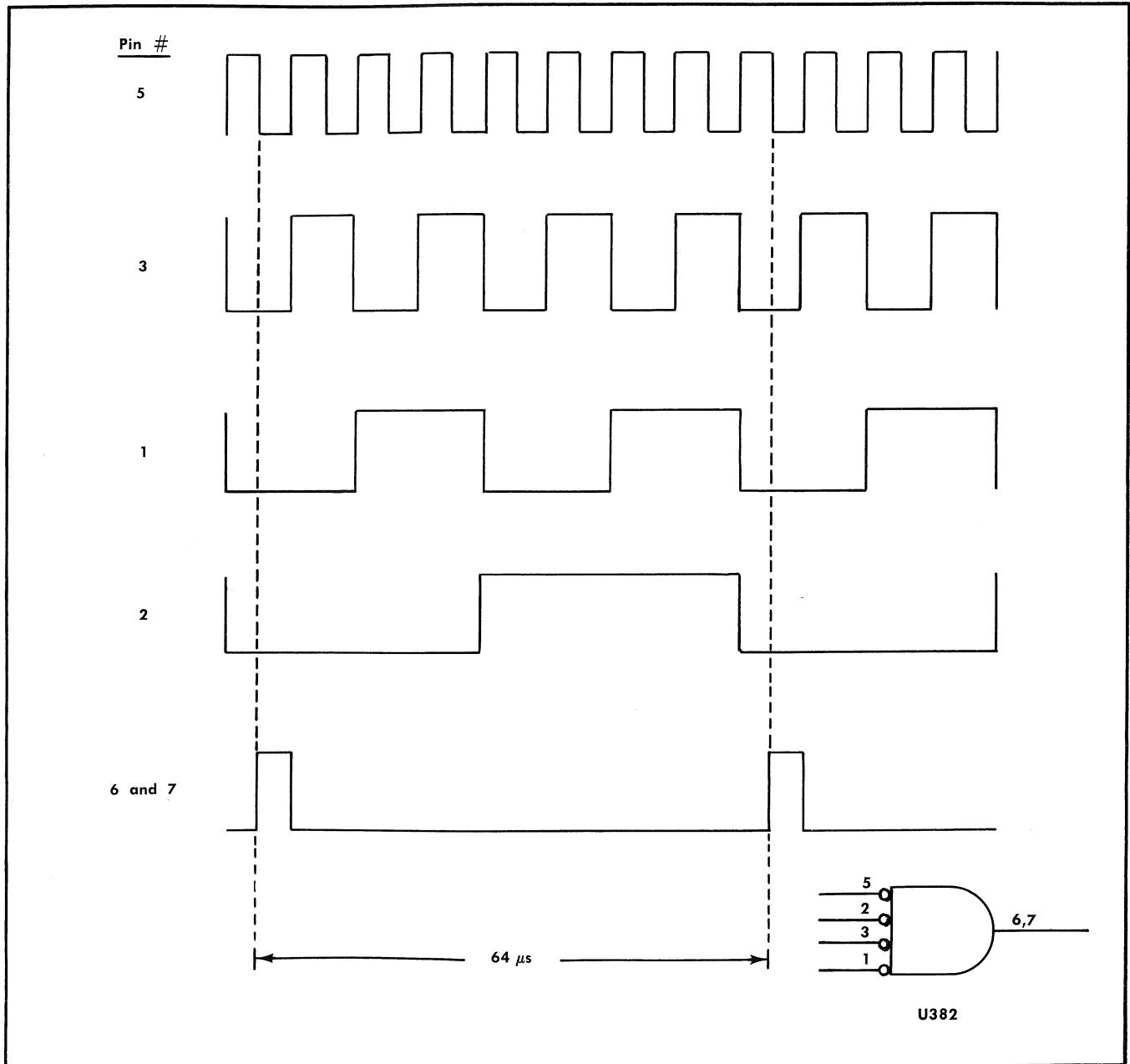

Fig. 3-14. Input and output signals for U382 (Bar Preset). Notice that an output signal ("high") is present at pins 6 and 7 only when all input signals are "low".

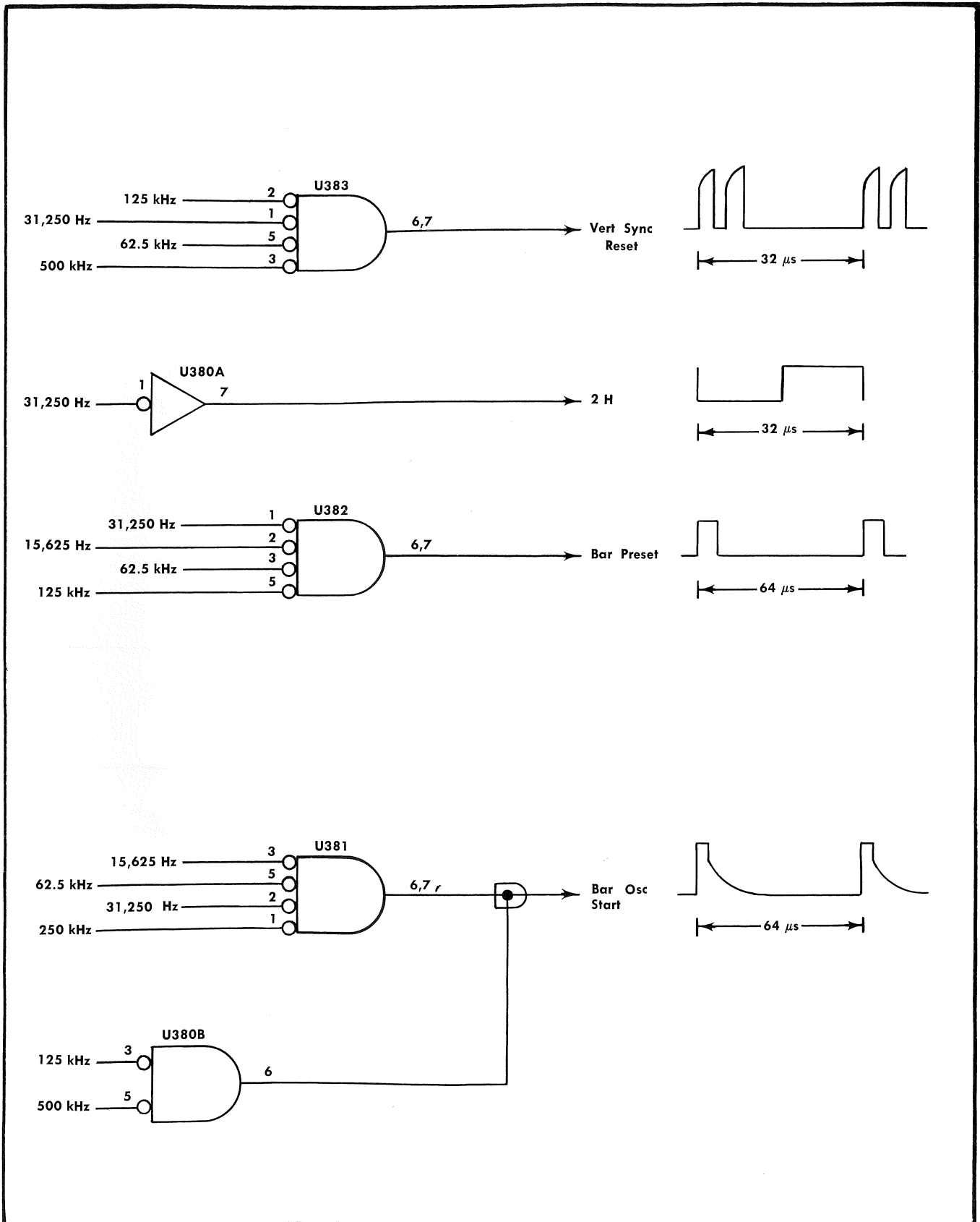

Fig. 3-15. Horizontal Logic, illustrating how outputs from Horizontal Counter are combined to compose various timing signals.

## Circuit Description—Type 141A/R141A

alternating in polarity at  $64 \mu\text{s}$  intervals. The preset input at pin 6 assures that the output signals start with the correct polarity at the beginning of every fourth field (once each frame).

If the V AXIS PHASING switch is set at either  $90^\circ$  or  $270^\circ$ , pin 1 or pin 3 is at  $+3.6 \text{ V}$ , locking the flip-flop in one mode. For example, with pin 3 at  $+3.6 \text{ V}$ , pin 5 will be high and pin 7 will be low. This is the condition when the V AXIS PHASING is set to  $90^\circ$ . In the  $270^\circ$  position, pin 1 is high, pin 5 is low and pin 7 is high.

The output signals appear at pin connectors AQ and AR and are then coupled to the  $0^\circ$ - $180^\circ$  Phase Shifter.

## Colour Bar Start/Stop Oscillator

Q405, Q410 and Q412 are the active elements in the Colour Bar Start/Stop Oscillator circuitry. The oscillator consists of L404, C404, Q405 and Q410, operating at a frequency of approximately  $625 \text{ kHz}$ . L404 adjusts the frequency of the oscillator. Sustaining feedback for the oscillator is via Q410 to the base of Q405. CR404 and CR405 in the tank circuit serve to limit the amplitude of oscillation.

Q412 is the output stage of the oscillator circuit. The signal coupled to the emitter of Q412 is of sufficient amplitude to drive Q412 from cutoff to saturation, resulting in a square-pulse output across R416 in the collector circuit. From the collector of Q412, the pulse is coupled to pin 2 of U406.

## Colour Bar Oscillator Control

U432 and Q420, the Colour Bar Oscillator Control, gates the oscillator off during the interval between the end of the blue chroma colour bar and the start of the white level bar. Various timing signals combine in U432 to form the gating signal which turns Q420 on and off.

R403/C403, R409/C409 and R413/C413 are decoupling networks to keep the oscillator signal from appearing on the regulated supply voltages.

## $\div 4$ Counter

The  $\div 4$  Counter, consisting of U406 and U408 is a two-stage progression of  $\div 2$  counters. U410 A and B are inverter/amplifier stages. Output frequency is approximately  $156 \text{ kHz}$ , giving a pulse period of  $6.5 \mu\text{s}$ . This period corresponds to the width of each colour bar segment.

## Colour Bar Chroma Counter and Logic

U415A, U424, U426, U428 and U430 are the Colour Bar Chroma Counter and Logic elements. These micrologic units perform the counting and logic functions which convert the oscillator  $\div 4$  signals into related green, red and blue chroma gate signals. Operation of the micrologic units is similar to that previously described under Horizontal Counter and Horizontal Logic. Output from the Colour Bar Chroma Counter and Logic circuit is coupled to the Staircase Timing Logic, Colour Bar Chroma Amplitude and Colour Bar Oscillator Control circuits.

## Delay

C418, R418, R419 and Q418 comprise the Delay circuit, which is adjustable to assure coincidence of colour bar chrominance and luminance steps.

The pulse signals at pin 6 of U410B (output of the  $\div 4$  Counter) are differentiated in passing through C418, resulting in positive- and negative-going spikes as a signal applied to Q418. R418 (Delay adjustment) varies the RC time constant of the waveform, thus setting the charge time of C418.

Q418 is normally biased at saturation. The negative-going excursions at the base bring Q418 into cutoff. Duration of cutoff is determined by the width of the negative-going spike at cutoff. See Fig. 3-16.

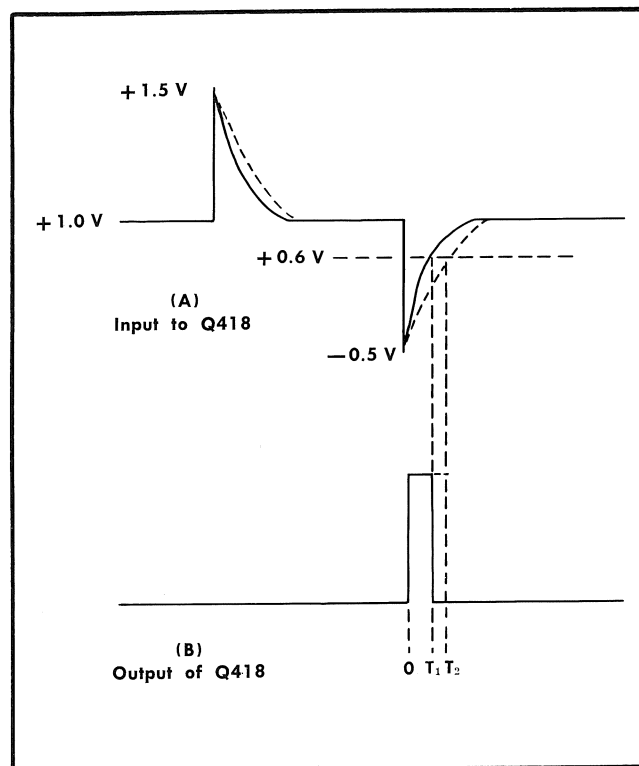

Fig. 3-16. Input and output waveforms for Q418. T1 and T2 are delay times with R418 set at each limit of adjustment.

U414, U416 and U420 are triggered by a negative-going excursion. Duration of the pulse from Q418 determines the time at which the negative excursion occurs.

## Colour Bar Luminance Counter and Logic

U414, U415B, U416, U418 and U420 are the Colour Bar Luminance Counter and Logic elements. This circuit is similar to the Chroma Counter and Logic circuit, except that luminance gates are generated corresponding to green, red and blue.

U422 provides a luminance setup level which ends at the end of black level to pin connector H. This signal is also coupled via pin connector G to U515 and U517 to provide part of the composite blanking output and as a gate signal to the APL Amplitude and APL Offset Chroma stages.

U423 provides a luminance setup level which ends at the end of the blue colour bar to pin connector K. The desired

setup level duration is selected by connecting the lead going to the Colour Bar Luminance Amplitude circuit (J 7 ) to either pin connector H or K. (See Operating Instructions).

Output from the Colour Bar Luminance Counter and Logic is coupled via pin connectors S, R and T to the Colour Bar Luminance Amplitude circuit.

### Horizontal Detail Timing

The Horizontal Detail Timing circuitry consists of U440A, Q440, Q445, Q448, Q450, Q455 and Q460. The circuit provides signals to the Composite Sync Logic circuits to control horizontal sync start and stop and equalizer stop functions. These signals, when combined with other signals coupled into the Composite Sync Logic circuits, form the complete composite sync signal.

A symmetrical square wave at twice the horizontal line rate is coupled through U440A to Q440 and Q445, which are connected as a conventional Miller integrator. C440 and R441 are the integrator timing components. Output of the integrator at the emitter of Q445 appears as a trapezoidal waveform. This signal is applied across resistive dividers in the base circuits of Q450, Q455 and Q460.

Fig. 3-17 illustrates the operation of the horizontal sync start circuit (Q450). Q455 and Q460 operate in a similar manner.

Q448 serves as a temperature compensation for the Miller integrator and Q450, Q455 and Q460.

### Composite Sync Logic

Composite Sync Logic functions are performed by U405, U436, U438 and U439. This circuit combines various timing signals to make up the composite sync signal.

The timing signals are combined by means of Type F $\mu$ L 914 micrologic units (integrated circuits). Fig. 3-18 shows con-

nections between micrologic units in the Composite Sync Logic circuit.

Signals which drive the various micrologic units and the resulting output signals are illustrated in Fig. 3-19. The composite sync signal at terminal A is coupled to Q550 to become part of the composite video signal. The signal at terminal A is also coupled to Q556, driving the Sync Out Amp which provides the signal output at the COMP SYNC connectors.

### Burst Logic

Burst Logic consists of Q465, Q470, U440, U460 and U470 connected in a manner that provides burst flag and gating signals of proper duration, occurring at the correct time on each line. When the BRUCH SEQ switch is on, the burst flag signals are keyed out at the correct times to provide Bruch-type burst operation. When BRUCH SEQ is off, burst flag signals are generated in accordance with NTSC encoding.

Fig. 3-20 shows the circuits which perform the Burst Logic functions.

U460 is connected as a three-input AND gate which requires a low on all input terminals (pins 1, 2 and 3) simultaneously to obtain an output signal (high). The output signal is differentiated and then coupled to pin 1 on U470. U440B is an inverting amplifier stage, coupling the burst stop signal to pin 5 of U470.

U470 is connected as set-clear flip-flop, controlled by the input signals at pins 1 and 5. Output signals appear at pins 6 and 7.

Control and output signals for Burst Logic are illustrated in Fig. 3-21. Note that during the time that pins 1, 2 and 3 of U460 are all low, an output (high) is present on pins 6 and 7.

When pin 1 on U470 goes to high, pin 6 goes to high. The flip-flop stays in this state until pin 5 goes high, which returns pin 6 to low. The time between these two events

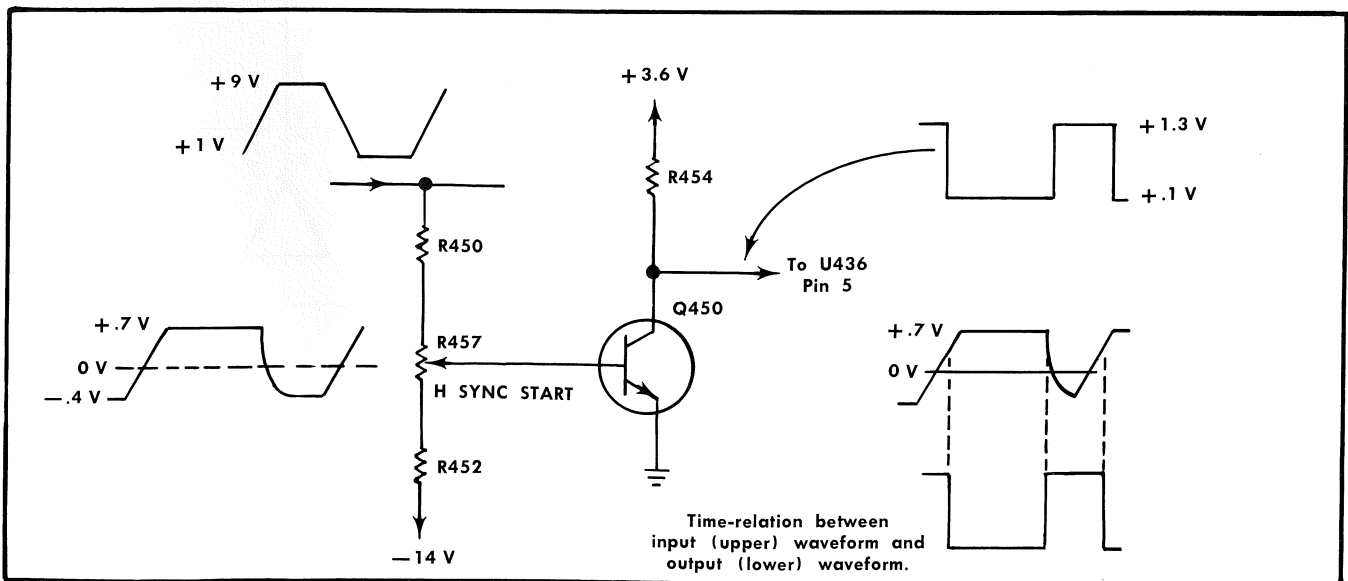

Fig. 3-17. H Sync Start circuit. Adjustment of R451 will select the point on the input ramp at which Q450 turns on, thus adjusting the time when the negative-going transition at the output occurs.

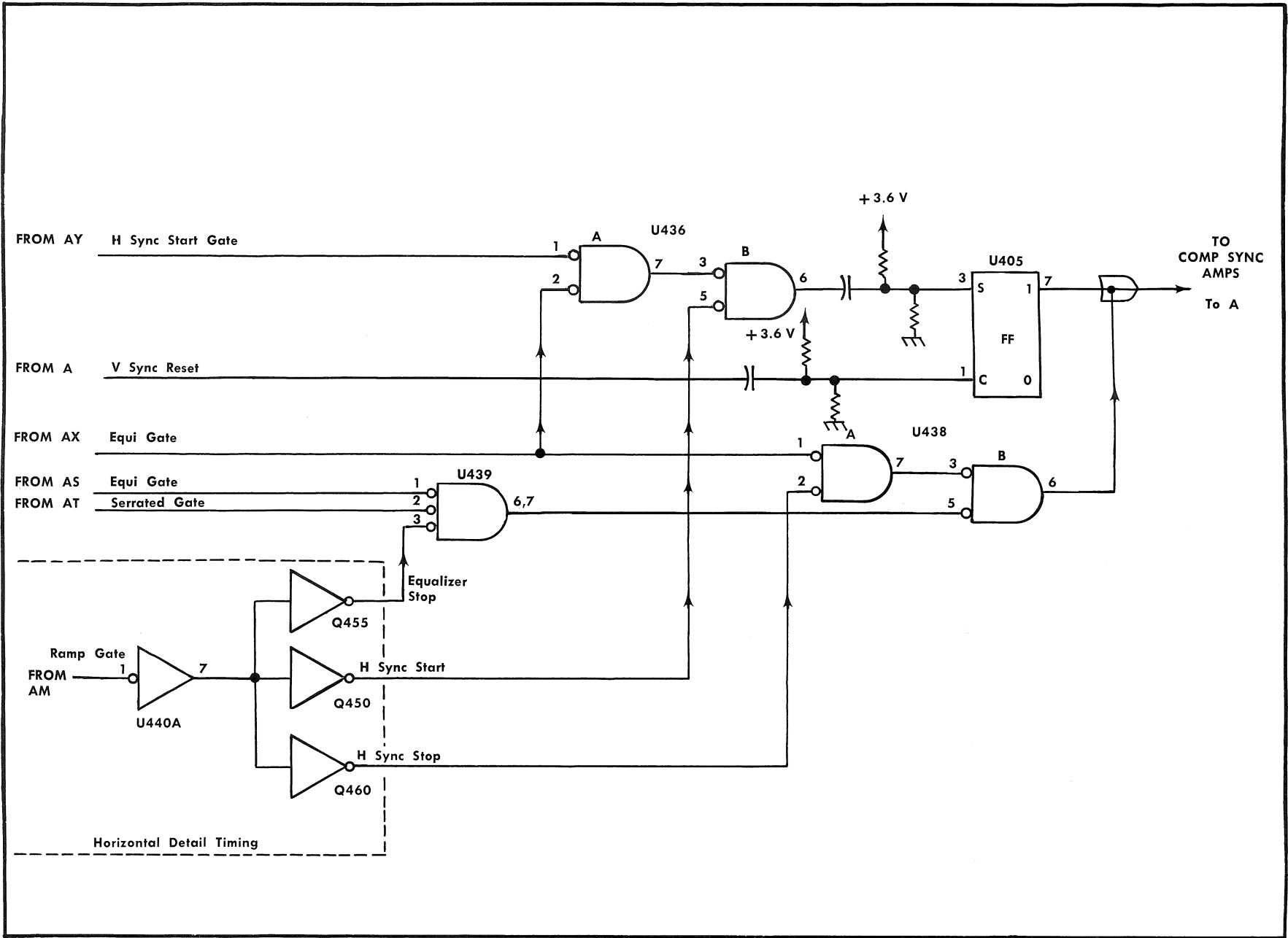
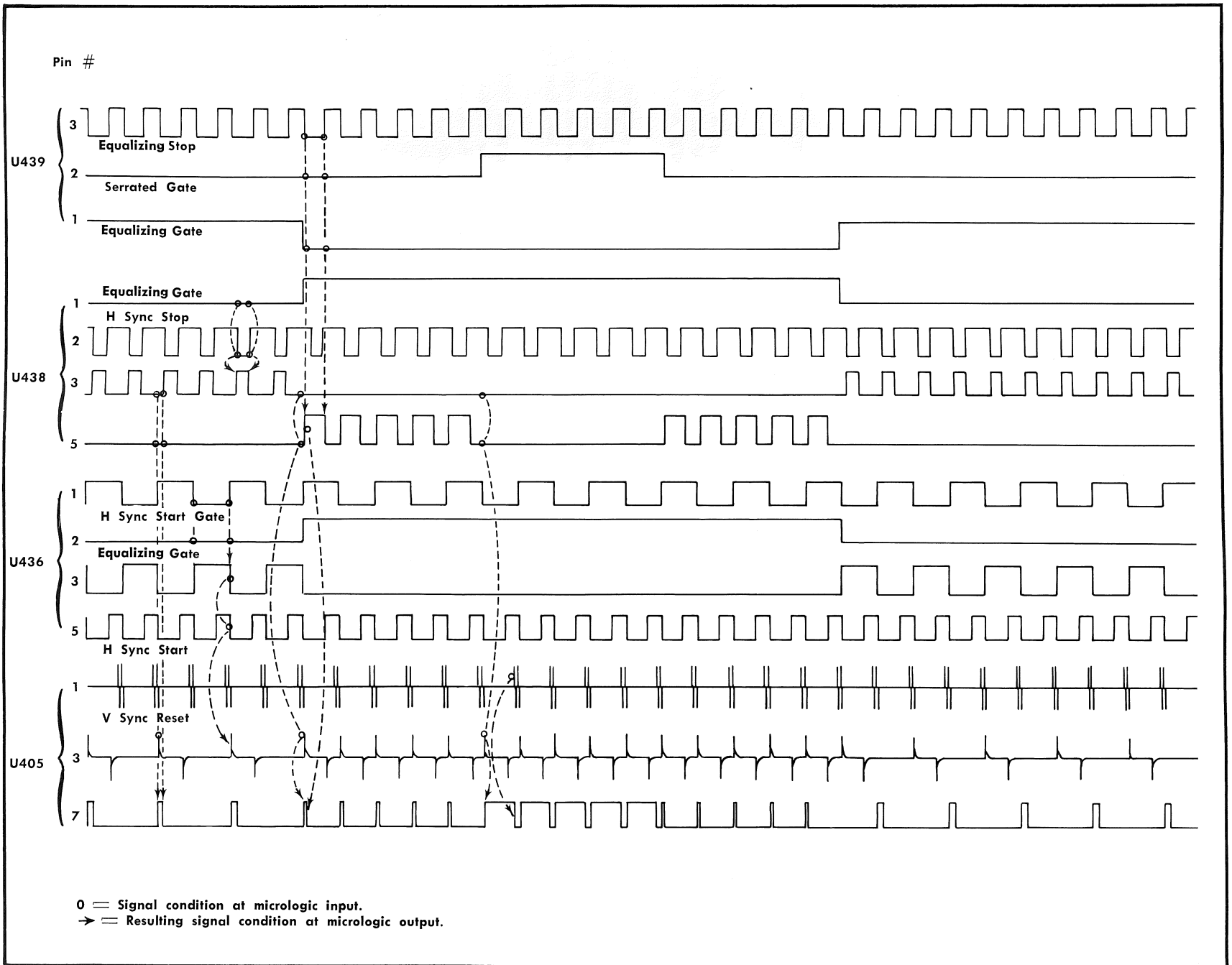

Fig. 3-18. Composite Sync Logic circuit elements.

Fig. 3-19. Composite Sync Logic. Signals are shown in time-related sequence.







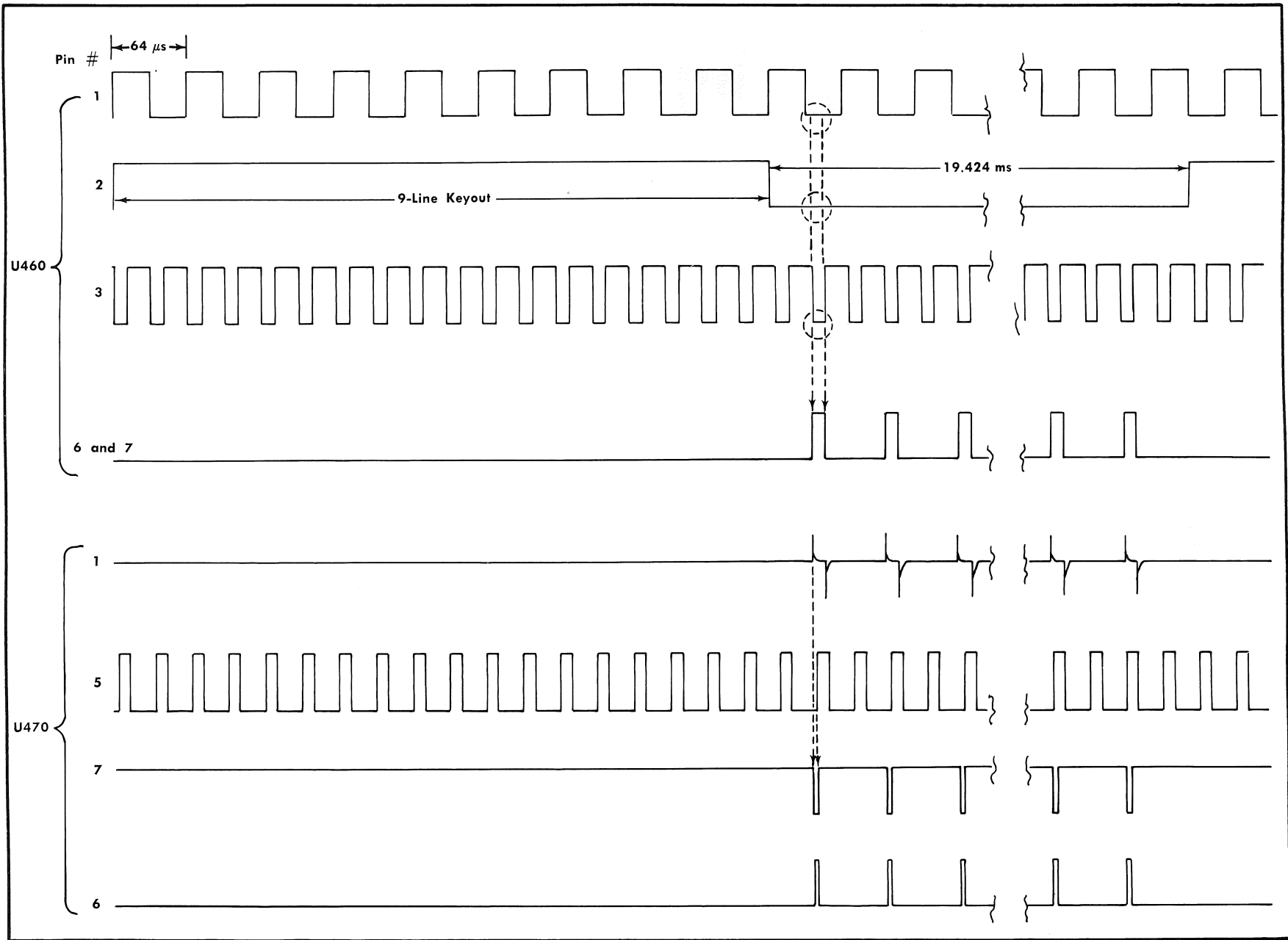

Fig. 3-21. Input and output signals of Burst Logic circuit. 9-line keyout is present when using Bruch sequence for burst. For NTSC, keyout is 7½ lines in duration.

### Circuit Description—Type 141A/R141A

Pin #			Pin #		
3	5	6	1	2	7
L	L	H	L	L	H
L	H	L	L	H	L
H	L	L	H	L	L
H	H	L	H	H	L

U502B
U501A

Fig. 3-22. Truth table for U501 and U502B. Note that pin 6 or 7 (output) is HIGH only when both pins 3 and 5 or pins 1 and 2 are LOW.

offset. By emitter-follower action, Q501 couples the pulse, now with sufficient drive capability, to terminal AF.

#### APL Offset Chroma

In the VAR APL mode of operation, Q511, Q513 and Q516 develop the APL offset chroma gating signal.

When the front-panel COLOUR BAR/MODULATED STAIRCASE switch is in the VAR APL position, the APL timing logic signal is generated as previously described and appears at the base of Q511.

Simultaneously, a signal at the horizontal blanking rate appears at terminal AJ and thus at the base of Q513. The emitters of Q511 and Q513 are connected together so that a negative signal at **both** bases switches the tail current from R511 to Q516 and thus to pin connector AK. (See Fig. 3-24C). From pin connector AK, the signal is coupled to the +V Filter (L661).

#### APL Amplitude

The APL Amplitude circuit consists of Q510, Q512 and Q515. This circuit is very much like the APL Offset Chroma circuit previously described.

The signal from APL Timing Logic appears at the base of Q510 (only in the VAR APL mode). At the same time, a signal at the horizontal blanking rate appears at the base of Q512. Q510 and Q512 emitters are connected together and to the emitter of Q515. R513 and S25 (AVERAGE PICTURE LEVEL switch) form the current long-tail to -15 V.

In the 12.5 position of S25, the emitter circuit is open and no current flows through Q515. In all other positions of S25, the signal current through Q515 is determined by the resistance of R513 and the series resistance (R20 through R28) selected by S25. The resulting signal current flows through R514 to terminal AM and thence to the Luminance Driver, Q725.

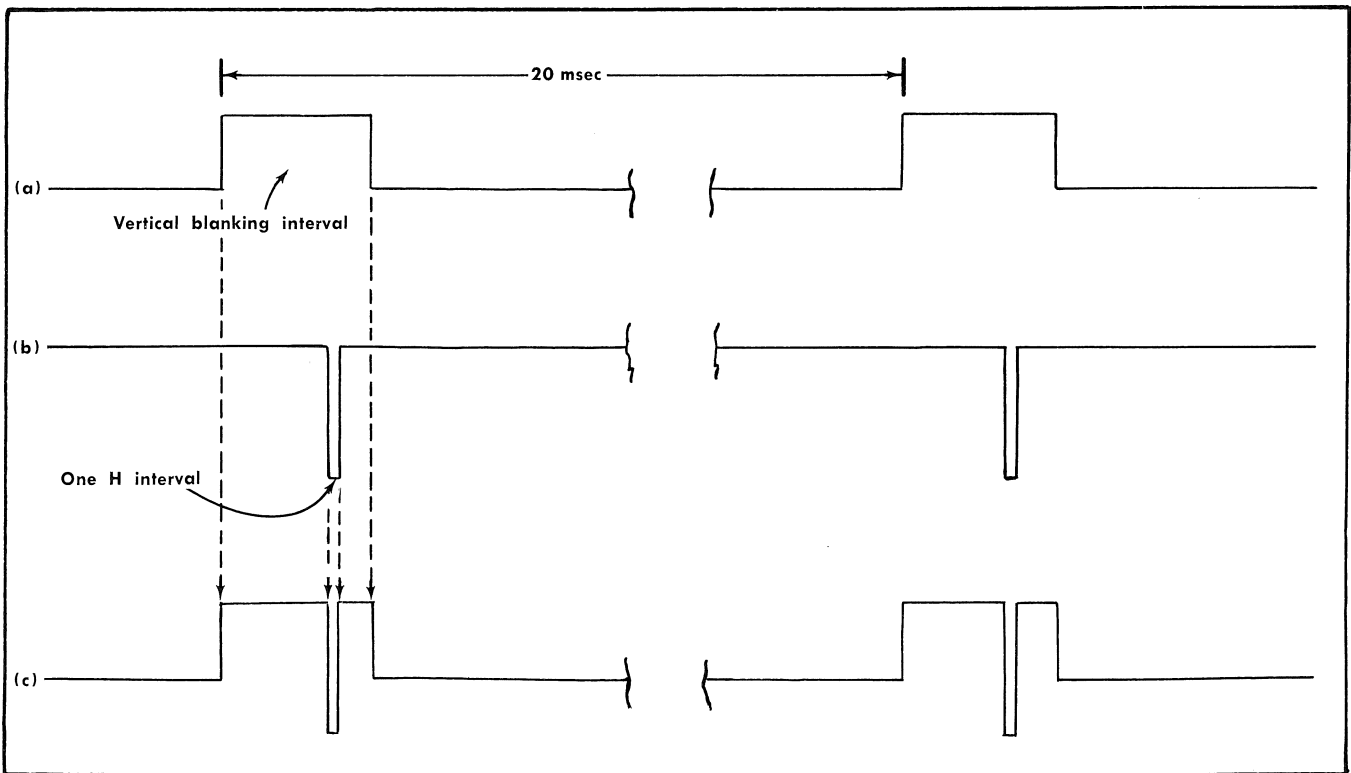

Fig. 3-23. (A) Signal at terminal AE. (B) Signal from U501, pin 6. (C) Combined signal at Q505 base.

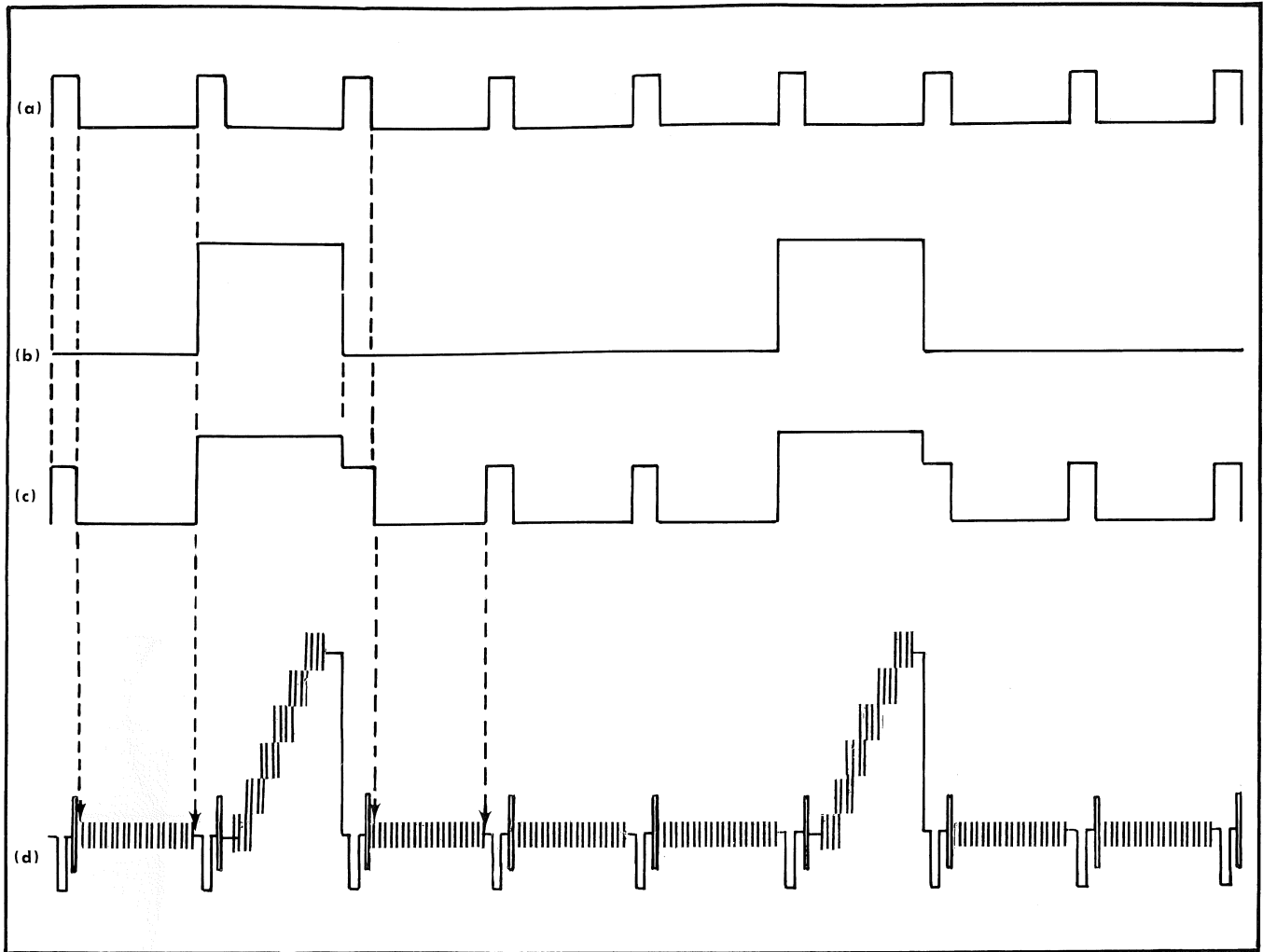

Fig. 3-24. APL Offset Chroma signals shown in relation to VAR APL mode output waveform. (A) Signal at the base of Q513. (B) Signal at the base of Q511. (C) Combined signal at the emitters of Q511, Q513 and Q516. (D) Composite video output signal in VAR APL mode. AVERAGE PICTURE LEVEL control set at 12.5.

### Composite Blanking Drive

U515 and U580 comprise the Composite Blanking Drive stages. From pin connector 0, the vertical blanking gate is coupled through U580 to pin 5 of U515. The horizontal blanking gate is coupled to pin 3 of U515 from pin connector AJ. U515B is connected as an AND gate, requiring a low path at both pins 3 and 5 to yield a high at pin 6. This high is inverted by U515A and is coupled to pin connector N. From pin connector N, the composite blanking signal is coupled to the Comp Blanking Output Amp and then to rear-panel jack J94 to become the COMP BLANKING output signal.

### Staircase Timing Logic

The Staircase Timing Logic consists of U508B, U510, U512, U514, U520, U522, U524, U526, U528, U530 and U532. This circuit is a series of 2-input gates and flip-flops which generate gating pulses of various widths by use of micrologic units. Operation of the circuit is similar to Composite Sync Logic, previously described.

### Staircase Luminance Amplitude

Q526, Q528, Q530, Q532, Q536, Q538, Q540, Q542, Q546 and Q548 comprise the Staircase Luminance Amplitude stages.

Output waveforms of the Staircase Timing Logic (and input waveforms to Staircase Luminance Amplitude) are shown in Fig. 3-25. Each waveform drives the base of a switching pair stage in the Staircase Luminance Amplitude or Staircase Chroma Amplitude circuits. These circuits are identical in configuration, so the circuit for Step 1 of the staircase (Q530 and Q532) will be described as an example.

The negative gate pulse arriving at the base of Q530 turns Q530 off, diverting the current through Q532. R531 in the emitter circuit sets the magnitude of the current through Q532, thus setting the amplitude of the step.

At a later instant (approximately  $6.5 \mu\text{s}$  later), a negative gate pulse arrives at the base of Q536, diverting current through Q538. This current is added to the current from Q532, combining in the common collector circuit. Fig. 3-25

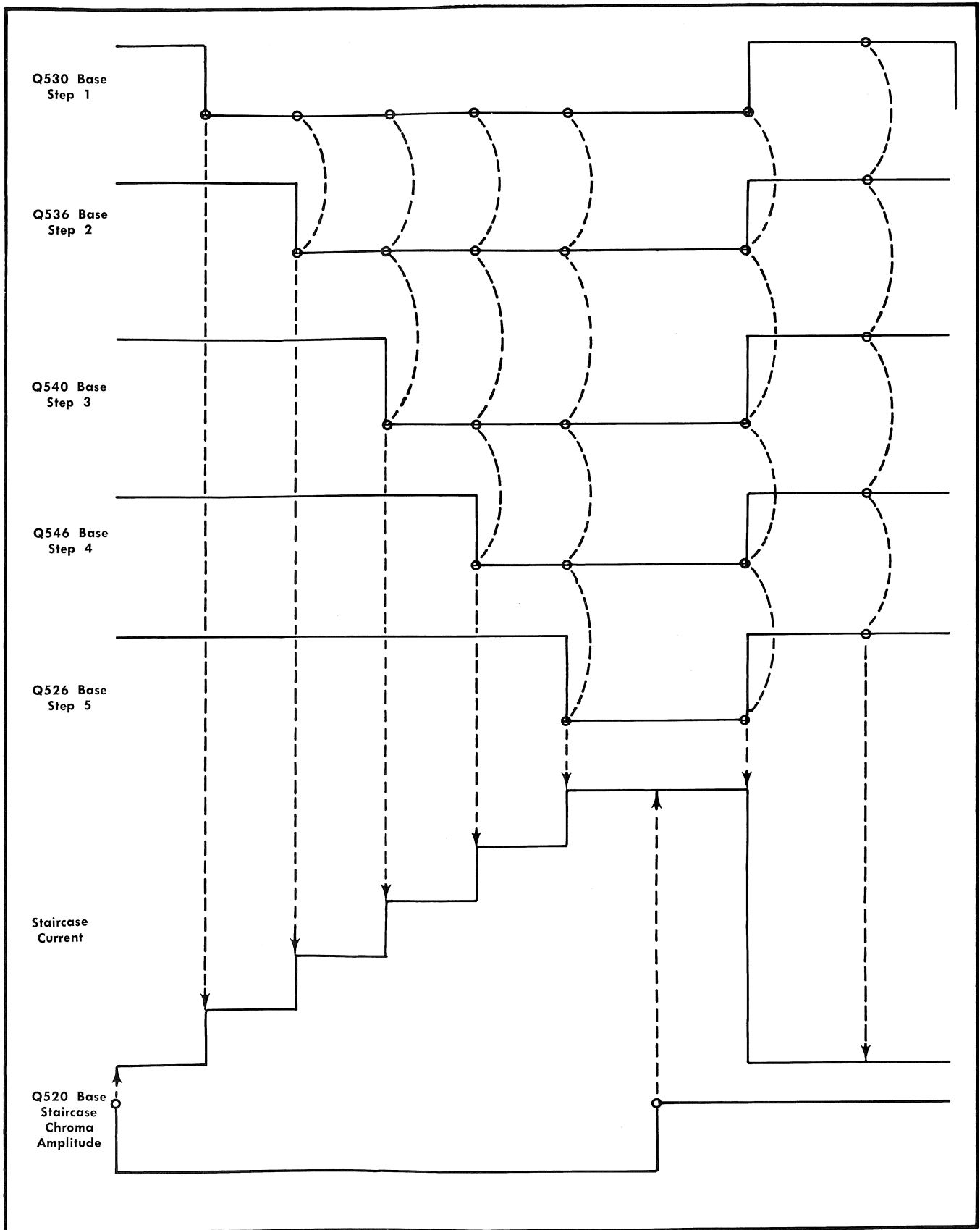

Fig. 3-25. Driving signals into Staircase Luminance Amplitude stages and resulting staircase current waveform at common collector output. Lower waveform shows time-relation of Staircase Chroma Amplitude gating signal.

illustrates the additive result of combining the individual step currents. Q725 on the Bar Drive and Video Out board serves as a common stage for combining the currents from each step amplitude stage.

CR525, CR530, CR535, CR540 and CR545 couple a positive level to the respective emitter circuits during the vertical blanking interval except during VITS, disabling the step generators. The negative step currents are coupled through these diodes when the front-panel STEPS switch is off (down).

### Composite Sync Amplitude

Composite sync at terminal AP is coupled to the current switching pair, Q550 and Q552. The signal passes through Q552 and R552 to be combined with the staircase waveform in the common collector circuit. Sync tips occur at points where current output is zero.

When the front-panel SYNC switch is turned off (down), +3.6 V appears at terminal AN. This diverts the signal current to the +3.6 V supply, removing the composite sync component.

### Staircase Chroma Amplitude

Q520 and Q522 operate in the same manner as the Staircase Luminance Amplitude stages. A signal for gating on chrominance during the staircase drives the switch pair Q520 and Q522 which deliver the signal current to the U and V Modulator board. R521 sets the magnitude of the current. Fig. 3-25 shows the relationship of the chrominance gating waveform and the staircase waveform. When the front-panel SUBCARRIER MOD switch is turned off (down), +3.6 V is coupled from terminal AH to the anode of CR 521, diverting the signal current through CR521 to the +3.6 V supply.

### Composite Sync Output

The composite sync waveform from Composite Sync Logic is coupled into terminal AP on the Staircase board. From terminal AP, the positive sync tip signal switches the current through R555 from Q556 to Q558.

### 2 MHz Filter

The high output impedance of Q558 serves as a constant current signal source to drive the 2 MHz Filter, L556 and L557. The filter has a sine-squared response and limits the risetime of the sync pulses to prevent ringing in transmission cables. The filter termination is R559 at the emitter of Q560.

### Comp Sync Output Amplifier

The Comp Sync Output Amplifier consists of Q560, Q570, Q572, Q574 and Q576 connected as an operational amplifier.  $R_f$  for the amplifier is R567. The input current is determined by R555.

The signal voltage at the emitter of Q560 will be only a few millivolts in amplitude but the amplifier input signal can be observed at the filter end of R559. Amplitude at this point is approximately 400 mV. Q572 and Q576 are parallel-connected to supply the negative-going drive to the two COMP SYNC outputs. Q574, an NPN, provides current for the positive-going excursions of the composite sync signal. R572 and R575 equalize the output currents from Q572 and Q576 emitters.

The composite sync signal is coupled from the emitter of Q574 and the emitters of Q572 and Q576 (via R572 and R575) to R578 and R579 and then to the front- and rear-panel COMP SYNC output connectors (J79 and J78 respectively). Amplitude of the output signal is 4 V P-P when terminated with a 75-ohm external load.

### U-V Quad Phase

4.43 MHz from the Level Controlled Output Amplifier is coupled to pin connector N on the U and V Modulator board. From pin connector N, the subcarrier signal (4.43 MHz) is connected to the primary of T601 and to L646, the U-V Quad Phase adjustment.

L646, C646 and C647 shift the phase of the subcarrier signal by 90°. The phase-shifted signal is then coupled to the primary of T651 via C648.

### 0°-180° Phase Shifter

At pin connectors R and P and the bases of Q640 and Q642, the polarity of the signal from the Phase Alternate Line (PAL) circuit alternates as previously described.

With the V AXIS PHASING switch set at 90°/270°, the signals at the bases of Q640 and Q642 will change polarity each horizontal line. Therefore, during one line Q640 will conduct and during the next line Q642 will conduct. When Q640 is conducting, Q642 is in cutoff and the collector of Q642 is positive. This positive potential appears at the base of Q646, bringing Q646 into saturation. When the PAL signal alternates, Q646 is turned off and Q644 goes into saturation. Polarity of the signal across T641 will, therefore, alternate each line.

Since L646 has shifted the phase of the subcarrier signal applied to T651 by 90°, when the 0°-180° phase shifter alternates the primary of T651 between 0° and 180°, the total phase difference between the signal across T601 and across T651 is alternately 90° and 270° (0° + 90° and 180° + 90°). The secondary of T651 drives the V modulator, while the U modulator is driven by the secondary of T601. The V signal is therefore alternately phase-shifted 90° and 270° from the U signal.

### +U and -U Filters, +V and -V Filters (Low-Pass Filter)

L611, C611 and C612 comprise the +U Filter. The -U Filter consists of L621, C621 and C622.

Bandwidth of each filter is approximately 2 MHz, preventing the U components from exceeding the 4.43 MHz modulated frequency. The +V Filter (L661) and the -V Filter (L671) are identical in operation to the +U and -U filters.

The blue component of the colour bar signal appears at pin connector H, becoming the +U signal. At pin connector I, the green, red and U burst components form the -U signal. In the 50% APL and VAR APL positions of the COLOUR BAR/MODULATED STAIRCASE switch, the staircase chrominance signal is coupled to pin connector J to become part of the -U signal.

The +V signal consists of the red and V burst components appearing at pin connector B. Staircase offset chrominance is coupled to pin connector C when the COLOUR BAR/MODULATED STAIRCASE switch is set at VAR APL. Blue and green components at pin connector E form the -V signal.

### U and V Double Balanced Modulators

Except for the phase-shifting of the V axis with respect to the U axis, the two modulators are identical in operation. A description of the U modulator will be given as an example.

The U modulator circuit consists of Q605, Q606, Q607, Q608, Q610, Q620, Q630, Q635A and Q635B.

The modulator stage, Q605, Q606, Q607 and Q608 is connected in a double-balanced configuration. This type of modulator cancels out the modulated carrier and the modulating signal, retaining the sidebands.

The subcarrier signal (4.43 MHz) across the secondary of T601 drives the bases of Q605, Q606, Q607 and Q608. Q635A and Q635B provide a differential signal current depending on the drive conditions. For example, if a + phase signal is required, a negative signal current is delivered through the +U Filter and its terminating grounded base stage (Q610) to the 1 k $\Omega$  equivalent load of R618. This develops a negative voltage at Q635A base, decreasing its collector current while increasing Q635B's collector current, since a constant current is delivered to both Q635 emitters by Q630.

Q605 and Q607 will switch the current from Q635A alternately from one end of T691 to the other at a 4.43 MHz rate, thus developing a 4.43 MHz square wave across the reflected load of R692.

Q606 and Q608 switch the current from Q635B alternately from one end of T691 to the other also, but 180° out of phase with the current delivered by Q635A. Thus, if the currents from Q635A and Q635B are equal, the current square waves in T691 will cancel. If Q635B delivers a greater current than Q635A, the signal developed across T691 will be proportional to the current difference and positive in polarity.

R625 and C628 balance the plus and minus U driver stages to minimize any residual subcarrier component. These are adjusted for minimum chrominance output when U and V are turned off (see Performance Check/Calibration Section).

### Bandpass Filter

The modulated output appears across T691 and is coupled through the Bandpass Filter, L691 and L693, to pin connector G. From pin connector G, the chrominance signal is coupled to the Chroma Output Amplifier.

The Bandpass Filter has an arithmetically symmetrical response with a center frequency of 4.43 MHz. Bandpass of the filter is approximately 2 MHz.

This bandwidth in conjunction with the 2 MHz U and V filters provides a chrominance bandwidth of approximately  $\pm 1.5$  MHz.

### Colour Bar Luminance Amplitude

Colour Bar Luminance Amplitude stages include Q701 through Q710, Q712, Q714, Q715 and Q720. In this circuit, red, green and blue luminance levels, white reference and setup levels are adjusted and their outputs are combined at the emitter of Q715.

The red, green and blue amplitude-setting stages, white reference and setup level stages are all similar in operation,

so a description of the green amplitude-setting stage will serve as an example.

Green luminance signals of negative polarity are coupled from terminal L to the base of Q708. The negative polarity turns Q708 off, diverting the current through Q710. Amplitude of the current is adjusted by R709. When the front-panel Y switch is set to off (down), +3.6 V is applied to the anode of CR708, diverting the signal current to the +3.6 V supply. A positive level is also applied to the anode of CR708 during the vertical blanking interval except during VITS.

To develop the white reference signal, the blue, red and green luminance signals are also coupled to the bases of Q703, Q705 and Q709 respectively. These signals are combined in the common emitter circuitry consisting of R703 and R706. R706 adjusts the current to the proper white reference amplitude. This signal current is coupled through Q707. Currents from the red, green and blue amplitude stages and the white reference stage are coupled together through R714 to the emitter of Q715.

### AMPLITUDE Switch

With the AMPLITUDE switch S750 set to 75%, 0 SETUP, the emitters of the red, blue and green and white reference amplitude stages are returned to -11.25 V. The emitter circuit of the setup amplitude stage (Q712) is open, so that setup is zero.

With the AMPLITUDE switch set to 100%, 0 SETUP, the emitters of the red, blue and green and white reference amplitude stages are returned to -15 V, increasing the luminance amplitudes to 100%. The emitter circuit of the setup amplitude stage is open, as before, resulting in zero setup.

When the AMPLITUDE switch is set to 75%, 25% SETUP, the emitters of the red, blue, green and white reference stages are returned to -11.25 V as before, and the emitter of the setup amplitude stage is now also returned to -11.25 V. The setup gate at pin connector J is coupled through Q712 and Q714 to combine with red, blue, green and white reference amplitudes.

### Luminance Driver and Narrow Band Filter

Composite sync and staircase steps at terminals H are coupled through Q725, a grounded-base stage. This prevents collector voltage changes with signal on the current switches. Output impedance of Q725 is high, serving as a constant-current signal source to drive the Narrow Band Filter, L725 and L726. Termination for the filter is R727. This filter minimizes step harmonics in the chrominance band.

### Wide Band Filter

The colour bar luminance levels are coupled through Q715 to the Wide Band Filter, L715 and L716. Except for the response of the filter, this circuit is very similar to that described for Q725. Response of the wide band filter has been selected to provide colour bar luminance steps extending to the allowable system bandwidth.

Q720, in the base circuits of Q715 and Q725, serves as a temperature compensation and sets the base potential on Q715 and Q725.

R730, Lum DC Level, provides a  $\pm$ DC current at the input



to the Luminance Output Amplifier, thus determining the output DC level.

Output signals from the two filters are combined at the input to the Luminance Output Amplifier.

### Luminance Output Amplifier

The Luminance Output Amplifier, consisting of Q735, Q740, Q745 and Q748, is connected as an operational amplifier. Characteristically, the input impedance is very low and the signal voltage at the emitter of Q735 will be only a few millivolts in amplitude. Signal drive into an operational amplifier is normally current rather than voltage.

$R_f$  for the amplifier consists of R746 and R747. Adjustment of R747 sets the gain of the stage, providing a calibrated luminance amplitude at the output connector.

Q745 sets the emitter voltage of Q740 and acts as a temperature compensation. CR735 in the base circuit of Q735 is also a temperature compensation.

The amplified luminance signal is coupled through R748 and R749 to the rear- and front-panel COMP VIDEO connectors respectively.

### Chroma Output Amplifier

The Chroma Output Amplifier, Q755, Q760, Q765 and Q768, is an operational amplifier. The circuit is very similar to the Luminance Output Amplifier previously described.

The chrominance signal at terminal AH is coupled to the emitter of Q755 through R754, which serves as  $R_i$  for the amplifier.  $R_f$  consists of R766 and R767. Adjustment of R767 sets the gain of the stage to provide a calibrated chrominance amplitude at the output connector.

Q765 and CR757 are temperature compensations. The amplified chrominance signal is coupled through R768 and R769 to the rear- and front-panel COMP VIDEO output connectors respectively.

Luminance and chrominance signals are combined into a composite signal at the output connectors. The parallel combinations R748/R768 and R749/R769 each provide an output impedance of 75 ohms at each respective connector.

Separate output amplifiers for luminance and chrominance are used in order to minimize distortions such as differential phase. If a common output amplifier were used, changes in the luminance signal could cause changes in the instantaneous operating level of the amplifier stages, introducing phase distortion to the chrominance signal.

### Colour Bar Chroma Amplitude

Q771 through Q776 and Q781 through Q786 comprise the Colour Bar Chroma Amplitude circuit. In this circuit, the amplitudes of the red, green and blue components of the +U, -U, +V and -V signals are adjusted to industry standards.

The circuit consists of 6 similar stages. Each of the three colours has an individual switching stage for the U component and a stage for the V component.

Since the stages are all similar, the blue amplitude-setting stage for the +U signal will be described as an example.

From the Colour Bar Chroma Count and Logic circuit, the blue chrominance signal is coupled to terminal N on the Bar Drive and Video Out board. The signal is then coupled from terminal N to the base of Q771. The signal at the base is of negative polarity, driving Q771 into cutoff during each pulse. The current that had been flowing through Q771 is now diverted to flow through Q772, R771 and R772. R772 is adjustable, permitting calibration of the +U signal magnitude. The signal is coupled through R779 to terminal S.

When the front-panel AMPLITUDE switch S750 is set to either 75%, 0 SETUP or 75%, 25% SETUP, the divider consisting of R771 and R772 is returned to -11.25 V. When the AMPLITUDE switch is set to 100%, 0 SETUP, the divider is returned to -15 V, thus increasing the current through Q772 and therefore increasing the magnitude of the blue +U signal.

R770 and C770 introduce a signal delay to permit time-coincidence adjustment of the +U signal to the -U signal.

CR771 couples a positive pulse (from terminal Y) to the emitters of Q771 and Q772 during the vertical blanking interval, diverting the signal current from Q772. When the front-panel COLOUR BAR U switch is set to off (down), +3.6 V is applied through terminal Y to the anode of CR771, again diverting the signal current.

From terminal N, the blue chroma signal is also coupled to the base of Q781 and through a circuit similar to that just described to form part of the -V signal.

### Burst Amplitude

The Burst Amplitude circuit consists of Q790, Q792, Q794 and Q796. This circuit contains two separate stages which are very similar to the Colour Bar Chroma Amplitude stages previously described.

The burst gating signal appears at terminal Q and the bases of Q790 and Q794. The gating pulse is negative, so during the pulse, the current that had been flowing through Q790 and Q794 is diverted through Q792 and Q796 respectively. R792 sets the magnitude of the signal current through Q792 and R796 sets the signal current through Q796. The current from Q792 is coupled to terminal R through R778 to become part of the -U signal. From the collector of Q796, the signal current is coupled through R789 to terminal U, forming part of the +V signal.

The front-panel BURST U switch applies +3.6 V to terminal X when it is turned off (down). This voltage is coupled to the anode of CR791, diverting the signal current to the +3.6 V supply. CR795 performs the same function for the BURST V signal.

## LOW VOLTAGE POWER SUPPLY 9

The Low Voltage Power Supply circuit provides the operating power for the Type R141A from three regulated supplies: -15 volts, +3.6 volts and +10 volts. Electronic regulation is used to provide stable, low ripple output voltages. All the supplies are current limited to prevent instrument damage in the event that a supply is inadvertently shorted to ground. The primary circuit of the transformer employs voltage and range selector plugs to permit selection of the line voltage operating range.

## Circuit Description—Type 141A/R141A

### Power Input

Power is applied to the primary winding of transformer T1 via the RFI Filter FL1, the POWER switch S4, 115 volt line fuse F2, Voltage Selector plug S3 and the Range Selector plug S2. The Voltage Selector plug S3 connects the split primaries of T1 in parallel for 115 volt range of operation, or in series for 230 volt range. A second line fuse, F3, is connected into the circuit when the Voltage Selector plug is placed in the 230 volt position to provide the correct protection for 230 volt operation. The current rating of F3 is one half of F2.

The Range Selector plug S2 allows the instrument to regulate properly on higher or lower than normal line voltages. Each half of the primary has taps above and below the 115 volt (230 V) point. As the Range Selector plug is moved from LO to M and then to HI, more turns are added to the primary winding. Therefore, whether the primary voltage has increased or decreased, the secondary voltage can be maintained at a nearly constant level ( $E_s = E_p \times N_s/N_p$ ).

The RFI Filter FL1 serves to prevent external RF interference from appearing across T1 and also prevents signals generated within the Type R141A from being introduced onto the AC line.

### —15 Volt Supply

The —15 volt supply provides the reference voltage for the +3.6 volt and +10 volt supplies (see Fig. 3-26). The reference for the —15 volt supply is a 9.1 volt zener VR870.

The output from the secondary winding (terminals U and W) of T1 is rectified by a full-wave rectifier consisting of CR861 and CR862. The rectified voltage is filtered by C61 and applied through a —15 Volt Series Regulator stage Q85 before being supplied to the load. Series Regulator Q85 and its Driver E.F. (Emitter Follower) Q880 are controlled by a Voltage Comparator consisting of Q875 and Q876 with associated components.

The base of Q875 in the Voltage Comparator stage is referenced by a 9.1-volt temperature-compensated zener diode, VR870. The voltage on the base of Q876 is determined by a divider network consisting of R885, —15 Volts control R886 and resistor R887. Variable resistor R886 adjusts the base voltage of Q876 so the output voltage of this supply is —15 volts within a tolerance of 3%. The collector current of Q875 is applied to Driver circuit Q880; this circuit controls Q85, connected as a series regulator.

Assume that the —15 volt supply tends to go in the positive direction (toward —14 volts). This positive-going voltage change is applied to the base of Q876, increasing the current through Q876. The increased current through Q876 decreases the conduction of Q875 and causes the voltage change at the collector of Q875 to be positive-going. This positive-going voltage change is applied to the base of Q880, causing the current through Q880 to increase. The increased current through Q880 causes a positive-going voltage change to occur at its emitter, and this change is applied to the base of Q85. Transistor Q85 increases its conduction. This increased conduction through Q85 effectively decreases its internal resistance and voltage drop, thus increasing the available voltage to the —15 volt supply to offset the original tendency for the supply to go toward —14 volts. Filter ca-

pacitor C885 suppresses sudden load changes that fall outside the bandwidth of the regulator circuit.

Network R880 and C880 suppresses any tendency for the Voltage Comparator stage to oscillate. C871 filters out any noise generated by VR870.

Q860 with associated components is an overload protection circuit. This transistor is normally cut off. However, if the —15 volt supply load current is excessive, current through R861 forward biases Q860. The collector current from Q860 flows through R816 (in the +10 volt supply) and causes the base of Q830 to go in the negative direction. The emitter of Q830 follows the base, pulling the base of Q35 down and shutting down the +10 volt supply.

The negative-going voltage change at the emitter of Q830 also appears across R831 and is coupled through R875 and C875 to the base of Q880. The emitter of Q880 follows this change, pulling down the base of Q85 which shuts down the —15 volt supply.

Notice, from this description, that an overload on the —15 volt supply causes both the +10 volt and —15 volt supplies to shut down.

### +3.6 Volt Supply

Full wave rectification for the +3.6 volt supply is provided by CR841 and CR842. The rectified voltage is filtered by C42 and applied to the +3.6 Volt Series Regulator stage Q55 before being applied to the load.

The error sensing divider resistors for the +3.6 volt supply are R855, +3.6 VOLTS control R856, and resistor R857. The —15 volt supply is used as the reference for the divider. Thus, if both the —15 volt and +3.6 volt supplies are operating properly, there should be a constant 18.6 volt difference between these two supplies.

Q845 and Q846 form a comparator circuit with the base of Q845 referenced at ground. When the +3.6 volt and —15 volt supplies are at the proper voltages, the base of Q846 is also at 0 volts. If either supply voltage changes, the comparator (Q845 and Q846) is unbalanced, resulting in an error signal at the base of Q850.

Since Q850 is an emitter follower, the polarity of the error signal is the same at the emitter of Q850 and the base of Q55. The error signal, applied to the base of Q55, is used to control the emitter-to-collector drop across Q55. In this way the output voltage is maintained at its rated value.

For example, if the +3.6 volt supply attempts to rise, the difference voltage across the error sensing divider resistors tends to increase and a fraction of this increase is applied as a positive-going error signal to the base of Q846. At the collector of Q846, the error signal is negative-going and this signal is applied to the base of Q850. The signal is also negative-going at the emitter of Q850, and this signal is applied to the base of Q55. The negative-going signal decreases the current through Q55 and thus increases the voltage drop across Q55 to offset the original tendency for the output voltage to increase.

Variable resistor R856 is the +3.6 VOLTS control to set the output of the supply at +3.6 volts within a tolerance of 3%. Q845 provides temperature compensation for Q846

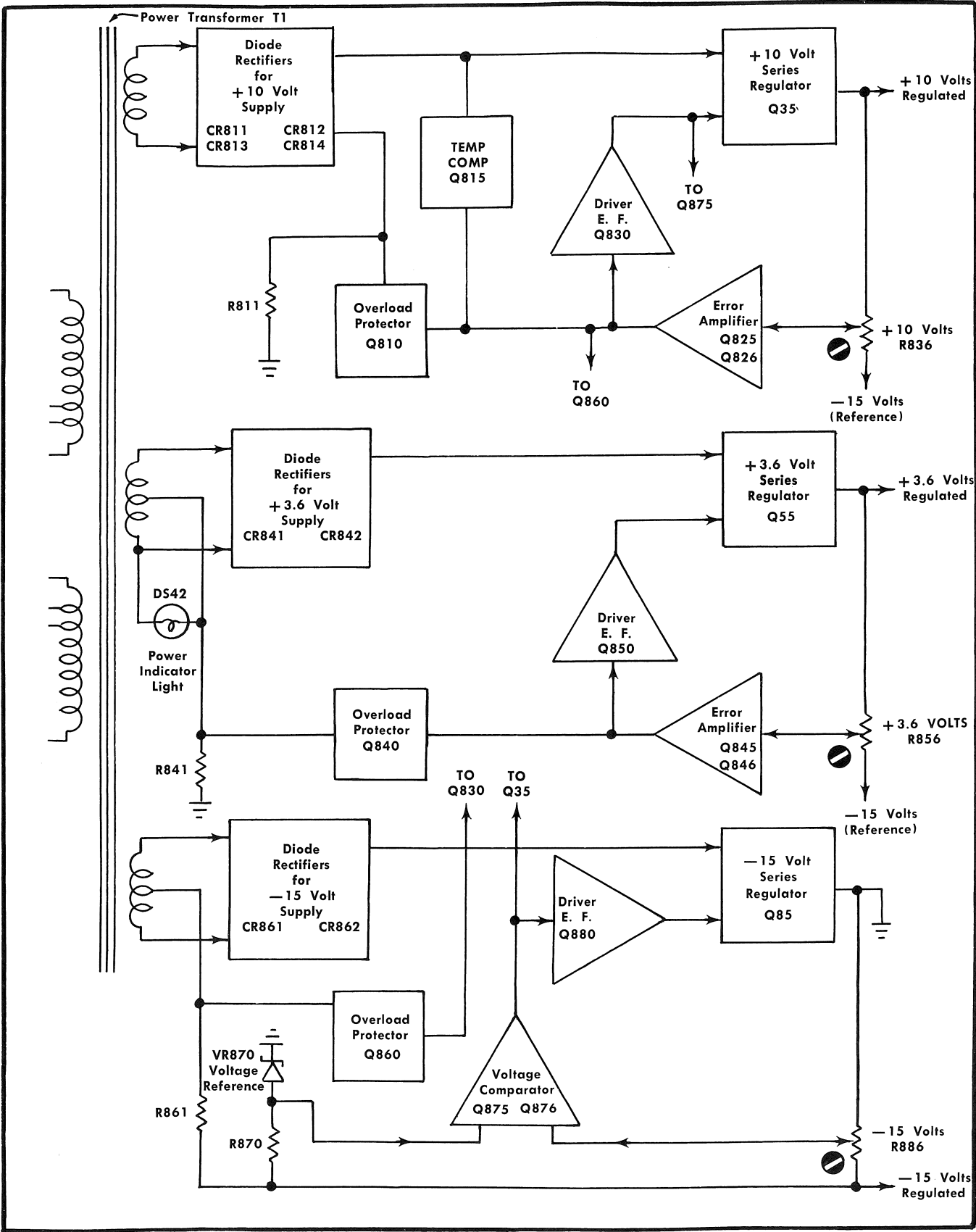

Fig. 3-26. Simplified block diagram of the low-voltage regulated power supplies.

## Circuit Description—Type 141A/R141A

and clamps the emitter of Q846 at about  $-0.6$  volt. Q840 provides overload protection for the  $+3.6$  volt supply. Q840 is normally in cutoff. If the load current for the supply becomes excessive, Q840 becomes forward biased and a negative-going signal occurs at its collector. This negative-going signal increases the internal resistance of Q55 to limit the current available at the output of the  $+3.6$  volt supply.

Network R850 and C850 prevents the  $+3.6$  volt regulator circuit from oscillating. Operating voltage for the POWER light DS42 is obtained from the connections across one half of T1 secondary winding at pins D and E on the Power Supply circuit board.

### +10 Volt Supply

The  $+10$  Volt Supply is similar to the  $+3.6$  Volt Supply. Rectified voltage for the  $+10$  volt supply is provided by the full-wave bridge rectifier consisting of CR811, CR812, CR813 and CR814. The rectified voltage is filtered by C11 and applied to Series Regulator Q35.

The error sensing divider resistors are R835,  $+10$  VOLTS control R836 and resistor R837. The Error Amplifier stage consists of Q825 and Q826 connected as a comparator. The base of Q825 is at ground, and, with the  $+10$  volt and the  $-15$  volt supplies at the proper voltages, the base of Q826 will be at 0 volts.

Any change in the  $+10$  volt output will appear at the base of Q826 and will thus be coupled to the base of Q830 as an error signal. This error signal will be coupled to the base of Q35, opposing any tendency for the supply voltage to change.

Q815 serves as a constant current source for Q826. Q810 provides overload protection for the  $+10$  volt supply. If the  $+10$  volt supply load current is excessive, current through R811 forward biases Q810, which shuts down the  $+10$  volt and the  $-15$  volt supplies in the same manner as described for Q860 in the  $-15$  volt supply.

## BUFFER AMPLIFIERS AND SWITCHING

Diagram 10 shows front-panel control lead connections.

Buffer amplifiers for driving several of the output connectors are also shown on this diagram. Circuit descriptions for the switches and buffer amplifiers have been previously covered along with the associated circuitry.

## OUTPUT AMPLIFIERS

The Output Amps board contains the output amplifiers for the FIELD DRIVE, PAL PULSE, COMP BLANKING, LINE DRIVE and BURST FLAG signals available at front- and rear-panel connectors.

These five amplifiers are all nearly identical in operation to the Comp Sync Output Amp previously described.

A description of the Field Drive Output Amp follows. This description may be used to gain an understanding of the operation of the other four amplifiers.

### Field Drive Output Amp

The Field Drive Output Amp consists of Q980, Q982, Q990, Q992, Q994, Q996 and Q998.

The field drive signal from the Field Drive Logic circuit is coupled to pin connector AE, and through R982 to the base of Q982. At pin connector AE, the field drive signal is positive in polarity with an excursion from approximately 0 V to  $+2$  V.

Q980 and Q982 operate as a switch pair. The positive signal at the base of Q982 drives Q982 into cutoff, diverting the current flowing in R981 through Q980.

The relatively high output impedance of Q980 serves as a constant current source to drive the filter, L984 and L985. The filter limits the risetime of the field drive signal to prevent ringing in transmission cables.

Q990, Q992, Q994, Q996 and Q998 form an operational amplifier. R990 is the feedback resistance. The input current is determined by R981. Q996 and Q998 are parallel-connected to supply the negative-going drive to the two FIELD DRIVE outputs. Q994, an NPN, provides current for the positive-going excursions whenever the amplifier is heavily loaded.

Q964 is common to all five output amplifiers, supplying temperature-compensated base bias for Q900, Q920, Q940, Q960 and Q980.

# SECTION 4

## MAINTENANCE

Change information, if any, affecting this section will be found at the rear of the manual.

### Introduction

This section of the manual contains information for use in preventive maintenance, troubleshooting and corrective maintenance of the Type R141A.

### PREVENTIVE MAINTENANCE

#### General

Preventive maintenance consists of cleaning, visual inspection and lubrication. Preventive maintenance performed on a regular basis may prevent instrument breakdown and will improve the reliability of this instrument. The severity of the environment to which the Type R141A is subjected determines the frequency of maintenance.

#### Cleaning

**General.** The Type R141A should be cleaned as often as operating conditions require. Accumulation of dirt in the instrument can cause overheating and component breakdown. Dirt on components acts as an insulating blanket that prevents efficient heat dissipation. It also provides an electrical conduction path.

#### CAUTION

Avoid the use of chemical cleaning agents which might damage the plastics used in this instrument. Avoid chemicals which contain benzene, toluene, xylene, acetone or similar solvents.

**Exterior.** Loose dust accumulated on the outside of the Type R141A can be removed with a soft cloth or small paint brush. The paint brush is particularly useful for dislodging dirt on and around the front-panel controls. Dirt which remains can be removed with a soft cloth dampened in a solution of water and mild detergent. Abrasive cleaners should not be used.

**Interior.** Dust in the interior of the instrument should be removed occasionally due to its electrical conductivity under high-humidity conditions. The best way to clean the interior is to blow off the accumulated dust with dry, low-velocity air. Remove any dirt which remains with a soft paint brush or a cloth dampened with a mild detergent and water solution. A cotton-tipped applicator is useful for cleaning in narrow spaces.

#### Lubrication

The reliability of switches and other moving parts can be maintained if they are kept properly lubricated. Use a clean-

ing-type lubricant (e.g., Tektronix Part No. 006-0172-00) for the switch contacts. This lubricant does not affect the electrical characteristics of the switch. Do not over-lubricate.

To lubricate the switch detent, use a heavier lubricant (e.g., Tektronix Part No. 006-0219-00). Particular attention should be given to the FULL FIELD COLOUR BAR/MODULATED STAIRCASE switch. For smooth action, place lubricant on the toggle end of the switch that moves the contacts.

#### Visual Inspection

The Type R141A should be inspected occasionally for such defects as broken connections, loose or disconnected pin connectors, improperly seated solid-state devices, damaged circuit boards and heat-damaged components.

The corrective procedure for most defects is obvious; however, particular care must be taken if heat-damaged components are found. Overheating usually indicates other trouble in the instrument; therefore, it is important that the cause of overheating be corrected to prevent recurrence of the damage.

#### Transistor and Integrated Circuit Checks

Periodic checks of the transistors and integrated circuits (ICs) used in the Type R141A are not recommended. The best indication of performance is the actual operation of the component in the circuit. Performance of the circuit is thoroughly checked during recalibration; substandard transistors and integrated circuits will usually be detected at that time.

#### Recalibration

To insure correct and accurate instrument operation, the instrument calibration should be checked each 1000 hours of operation or at least every 6 months. Performance Check and Calibration procedures are given in Section 5.

The calibration procedure can be helpful in isolating major troubles in the instrument. In some cases, minor troubles not apparent during normal operation may be revealed and corrected during calibration.

### CORRECTIVE MAINTENANCE

#### General

Corrective maintenance consists of component replacement and instrument repair. Special techniques or procedures required to replace components in this instrument are described here.

## Obtaining Replacement Parts

**Standard Parts.** All electrical and mechanical replacement parts for the Type R141A can be obtained through your local Tektronix Field Office or representative. However, many of the standard electronic components can be obtained locally in less time than is required to order them from Tektronix, Inc. Before purchasing or ordering replacement parts, consult the Parts List for value, tolerance and rating.

### NOTE

When selecting replacement parts, it is important to remember that the physical size and shape of a component may affect its performance at high frequencies. All replacement parts should be direct replacements unless it is known that a different component will not adversely affect instrument performance.

**Special Parts.** In addition to the standard electronic components, some special parts are manufactured or selected by Tektronix, Inc. to meet specific performance requirements, or are manufactured specifically for Tektronix, Inc. These special parts are indicated in the Parts List by an asterisk preceding the part number. Most of the mechanical parts used in this instrument have been manufactured by Tektronix Inc. Order all special parts directly from your Tektronix Field Office or representative.

**Ordering Parts.** When ordering replacement parts from Tektronix, include the following information:

1. Instrument type.
2. Instrument serial number.
3. A description of the part (if electrical, include circuit number).
4. Tektronix Part Number.

## Soldering Techniques

### WARNING

Disconnect the instrument from the power source before soldering.

**Circuit boards.** Use ordinary 60/40 solder and a 25 to 40 watt pencil type soldering iron on the circuit boards. A higher wattage soldering iron may separate the etched wiring from the base material.

The tip should be made of copper and have a chisel or beveled shape, with a  $\frac{1}{8}$  inch width. The tip of the iron should be clean and properly tinned for best heat transfer to the solder joint.

The following technique should be used to replace a component on a circuit board:

1. Grip the component lead with long-nose pliers. Touch the soldering iron to the lead at the solder connection. Do not lay the iron directly on the board.
2. When the solder begins to melt, pull the lead out gently. This should leave a clean hole in the board. If not, the hole

can be cleaned by reheating the solder and placing a sharp object such as a toothpick into the hole to clean it out. A vacuum-type de-soldering tool can also be used for this purpose. If the removal is not accomplished in the first few seconds of heat application, go to another connection or wait a few minutes before reheating the connection. This is to avoid transferring too much heat to the circuit board base material.

3. Bend the leads of the new component to fit the holes in the board. If the component is replaced while the board is mounted in the instrument, cut the leads so they will just protrude through the board. Insert the leads into the holes in the board so the component is firmly seated against the board (or as positioned originally). If it does not seat properly, heat the solder and gently press the component into place.

4. Touch the iron to the connection and apply a small amount of solder to make a firm solder joint; do not apply too much solder. To protect heat-sensitive components, hold the lead between the component body and the solder joint with a pair of long-nose pliers (see Fig. 4-1) or other heat sink.

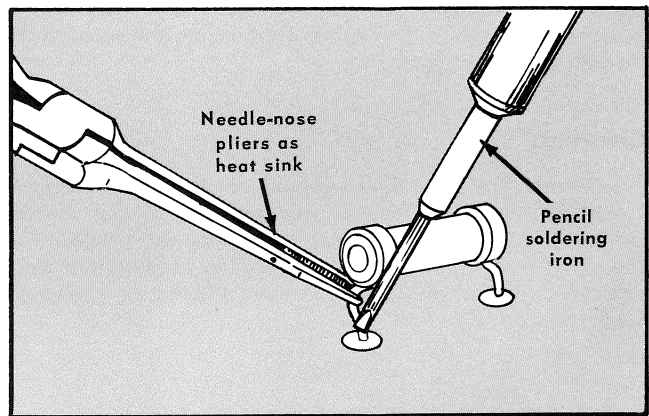

Fig. 4-1. Use of a heat sink to protect components during soldering.

5. Clean the area around the solder connection with a flux-remover solvent. Be careful not to remove information printed on the board.

**Metal Terminals.** When soldering to metal terminals (e.g., switch terminals, potentiometers, etc.), ordinary 60/40 solder can be used. Use a soldering iron with a 40- to 75-watt rating and  $\frac{3}{16}$  inch wide wedge-shaped tip.

Observe the following precautions when soldering to metal terminals:

1. Apply only enough heat to make the solder flow freely.
2. Apply only enough solder to form a solid connection. Excess solder may impair the function of the part.
3. If a wire extends beyond the solder joint, clip off the excess.
4. Clean the flux from the solder joint with a flux-remover solvent.

## Component Replacement

### WARNING

Disconnect the instrument from the power source before replacing components.

**Circuit Boards.** If the circuit board is damaged beyond repair, replacement can be made of the entire assembly including all soldered-on components, or of the board alone. Part numbers are given in the Mechanical Parts List for either the completely wired or the unwired board. The following procedure outlines the removal and replacement of the boards.

#### Removal:

1. Check the colour code of the wires in the instrument against the appropriate illustration given in this section of the manual (see Fig. 4-6 through 4-15). Note any differences so that when the board is replaced, the wires can be reconnected to their original pins.
2. Disconnect all the wires from the pin connectors on the board.
3. Remove board hold-down screws (Subcarrier Output Amp and Power Supply and Output Amp boards only). Unsnap one edge of the board from the plastic mounting clips.
4. Remove the board.

#### Circuit Board Replacement:

1. Insert one edge of the circuit board so that the board notches fit into the plastic mounting clips.
2. Snap the board into place and check that the board is firmly mounted in the plastic clips.
3. Reconnect all wires to their respective pin connectors on the board.

**Transistor and Integrated Circuit Replacement.** Transistors and integrated circuits (ICs) should not be replaced unless they are actually defective. Replacement or exchange of components may affect the calibration of the instrument. If a transistor or integrated circuit is removed during routine maintenance, return it to its original socket.

Any replacement component should be of the original type or a direct replacement. Bend the leads to fit the socket and cut the leads to the same length as on the component being replaced. Use Fig. 4-2 as a reference for insertion.

The chassis-mounted power supply transistors and their mounting bolts are insulated from the chassis. In addition, silicone grease is used to increase heat transfer capabilities. Re-install the insulators and replace the silicone grease when replacing these transistors. The grease should be applied to both sides of the mica insulators, and should be applied to the bottom side of the transistor where it comes in contact with the insulator.

### WARNING

1. Silicone grease should be handled with care and should be kept away from the eyes. Wash hands thoroughly after contact with the grease.
2. Voltages are present on the exterior surface of the chassis-mounted power supply transistors

if power is applied to the instrument and the POWER switch is on.

After any component is replaced, check the operation and calibration of the associated circuits.

**Indicator Lamp Replacement.** The oven lamp can be removed from the front panel. To remove the lamp, unscrew the lens; use fingernails to grip the lamp, and pull outward. To replace the lamp, insert it and rotate it while applying light pressure. After the pins align with the socket, push the lamp fully into place. Replace the lens.

To remove the Power On indicator lamp, first remove the top cover from the instrument. Then, reach behind the front panel and unplug the lamp from its holder. To replace the lamp, reverse the procedure.

**Fuse Replacement.** Both line fuses are contained in plastic holders in the cover for the Line Voltage Selector Assembly at the rear of the instrument. To remove the fuses, disconnect the line cord from the power source and remove the cover of the assembly. Push on the end of the fuse to be removed and slide it out of the holder. Replace the fuse in a similar manner, being sure the cover fits snugly against the rear panel of the instrument.

Use only the correct value replacement fuse. A smaller value will tend to blow out; a larger value will not provide adequate protection for the instrument. Only the upper fuse within the assembly ( $1/2$  A) is used for 115-volt operation. However, for 230-volt operation both the upper and lower fuse ( $1/4$  A) must be installed.

**Switches.** If a switch is defective, replace the entire assembly. Replacement switches can be ordered by referring to the Parts List for the applicable part numbers.

When replacing a switch, tag the leads and switch terminals with corresponding identification tags as the leads are disconnected. Then, use the old switch as a guide for installing the new one. An alternative method is to draw a sketch of the switch layout and record the wire colour at each terminal. When soldering to a new wafer-type switch, be careful that the solder does not flow beyond the rivets on the switch terminals. Spring tension of the switch contact can be destroyed by excessive solder.

**Power Transformer Replacement.** Be sure to replace only with a direct replacement Tektronix transformer.

When removing the transformer, tag the leads with the corresponding terminal numbers to aid in connecting the new transformer. After the transformer is replaced, check the performance of the complete instrument using the Performance Check procedure.

## TROUBLESHOOTING

### Introduction

The following information is provided to facilitate troubleshooting of the Type R141A. Information contained in other sections of this manual should be used along with the following information to aid in locating the defective compo-

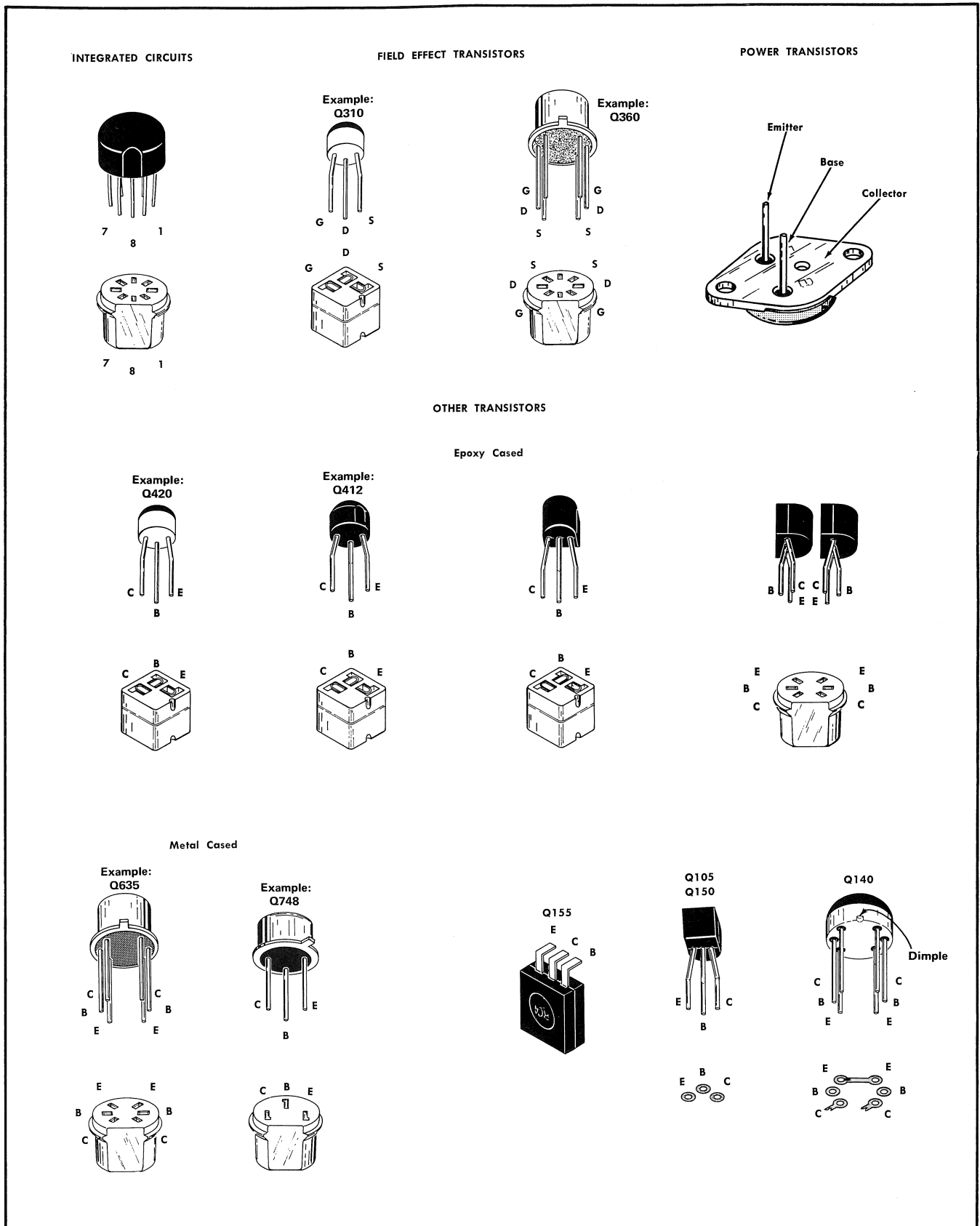

Fig. 4-2. Electrode configuration for socket mounted Integrated Circuits and transistors. Q140 may be epoxy cased as shown or may be metal cased as shown for Q635.



ment. An understanding of the circuit operation is very helpful in locating troubles. See the Circuit Description section for complete information.

## Troubleshooting Aids

**Diagrams.** Circuit diagrams are provided on foldout pages in Section 8. The component number and electrical value of each component in this instrument are shown in the diagrams. Each main circuit is assigned a diagram number. Table 4-1 lists the main circuits in the Type R141A and their assigned diagram numbers. Important voltage and waveforms are also shown on the diagrams. The portions of the circuit mounted on circuit boards are enclosed with a blue line.

TABLE 4-1

Diagram	Circuit
1	Subcarrier Oscillator and Output
2	Vertical
3	Horizontal Colour Lock
4	Horizontal Detail Timing
5	Staircase
6	U and V Modulator
7	Bar Drive and Video Out
8	Colour Bar Chroma & Burst Ampl
9	Power Supply
10	Buffer Amps and Switching
11	Output Amps

**Switch Wafer Identification.** The VERTICAL INSERTION TEST SIGNAL LINE selector switch shown on the Vertical diagram is coded to indicate the position of the wafer in the complete switch assembly. The numbered portion of the code refers to the wafer number counting from the front, or mounting end of the switch, toward the rear. The letters 'F' and 'R' indicate whether the front or rear of the wafer performs the particular switching function. For example, a wafer designated 3R on the diagram indicates that the rear of the third wafer is used for this particular switching function.

**Circuit Boards.** Fig. 4-5 shows the location of each circuit board within the instrument. Fig. 4-6 through 4-15 show a full view of each circuit board. Each electrical component on the boards is identified by its circuit number, and all wire colour codes are shown. These pictures, used along with the diagrams, aid in locating the components on the circuit boards.

**Wire Colour Code.** All insulated wires in the Type R141A are colour coded to facilitate circuit tracing. Table 4-2 summarizes the coding system used by Tektronix, Inc. for chassis wiring in all its instruments at this time.

TABLE 4-2

Colour Code	Significance
Black	Chassis ground
White on Black	Floating ground
Yellow on Green	Safety ground
Brown <sup>1</sup>	Filament and heaters
Gray <sup>1</sup>	AC line
White <sup>1</sup>	Signal
Red <sup>1</sup>	B+
Violet <sup>1</sup>	B—

<sup>1</sup>Colour stripes are used on these wires as an aid to circuit tracing.

Table 4-3 is provided to list the wire colour code for the regulated non-decoupled DC power supply voltages used in the Type R141A.

TABLE 4-3

Type R141A Power Supply Wire Colour Code

Supply	Colour Code
−15 V	Black on Violet
+3.6 V	Black on Red
+10 V	Brown on Red

**Resistor Colour Code.** In addition to the brown composition resistors, metal film resistors (identifiable by their gray or light blue colour) are used in the Type R141A. The resistance value of composition and metal film resistors is colour-coded on the components with the standard EIA colour code. The colour code is read starting with the stripe nearest the end of the resistor. Composition resistors have four stripes consisting of two significant figures, a multiplier and a tolerance value. Metal-film resistors have five stripes which consist of three significant figures, a multiplier and a tolerance value (see Fig. 4-3).

**Capacitor Markings.** The capacitance value of a common disc capacitor or small electrolytic is marked in microfarads on the side of the component body. The white ceramic capacitors used in the Type R141A are colour-coded in picofarads using a modified EIA code (see Fig. 4-3).

**Diode Colour Code.** The cathode end of each glass-enclosed diode is indicated by a stripe, a series of stripes, or a dot. For metal-enclosed diodes, the anode and cathode are marked on the case. When the diode is a JEDEC registered device, a series of stripes indicates the diode type number using the EIA colour-code system. On diodes manufactured especially for Tektronix, a four-band colour code system is used, the first band of which is either blue or pink. On the latter type of diodes, the last three bands identify the diode within a class of part numbers (e.g., a diode colour-coded blue (or pink) brown gray green probably indicates Tektronix Part Number 152-0185-00). When in doubt, consult the Parts List.

**Transistor and IC Lead Configuration.** Fig. 4-2 shows the lead configuration for socket mounted transistors, FETs and ICs used in the Type R141A.

## Troubleshooting Equipment

The following equipment is useful for troubleshooting the Type R141A:

### 1. Transistor Tester

Description: Tektronix Type 576 Transistor-Curve Tracer or equivalent.

Purpose: To test the semiconductors used in this instrument.

### 2. Multimeter

Description: VOM, 20,000 ohms/volt DC. 0 to 30-volt range DC, 0 to 150-volt range AC; accuracy within 0.3% to measure power supply output voltages, within 3% for other circuit voltage readings; ohmmeter, 0 to 50 megohms. Test prods must be insulated to prevent accidental shorts.

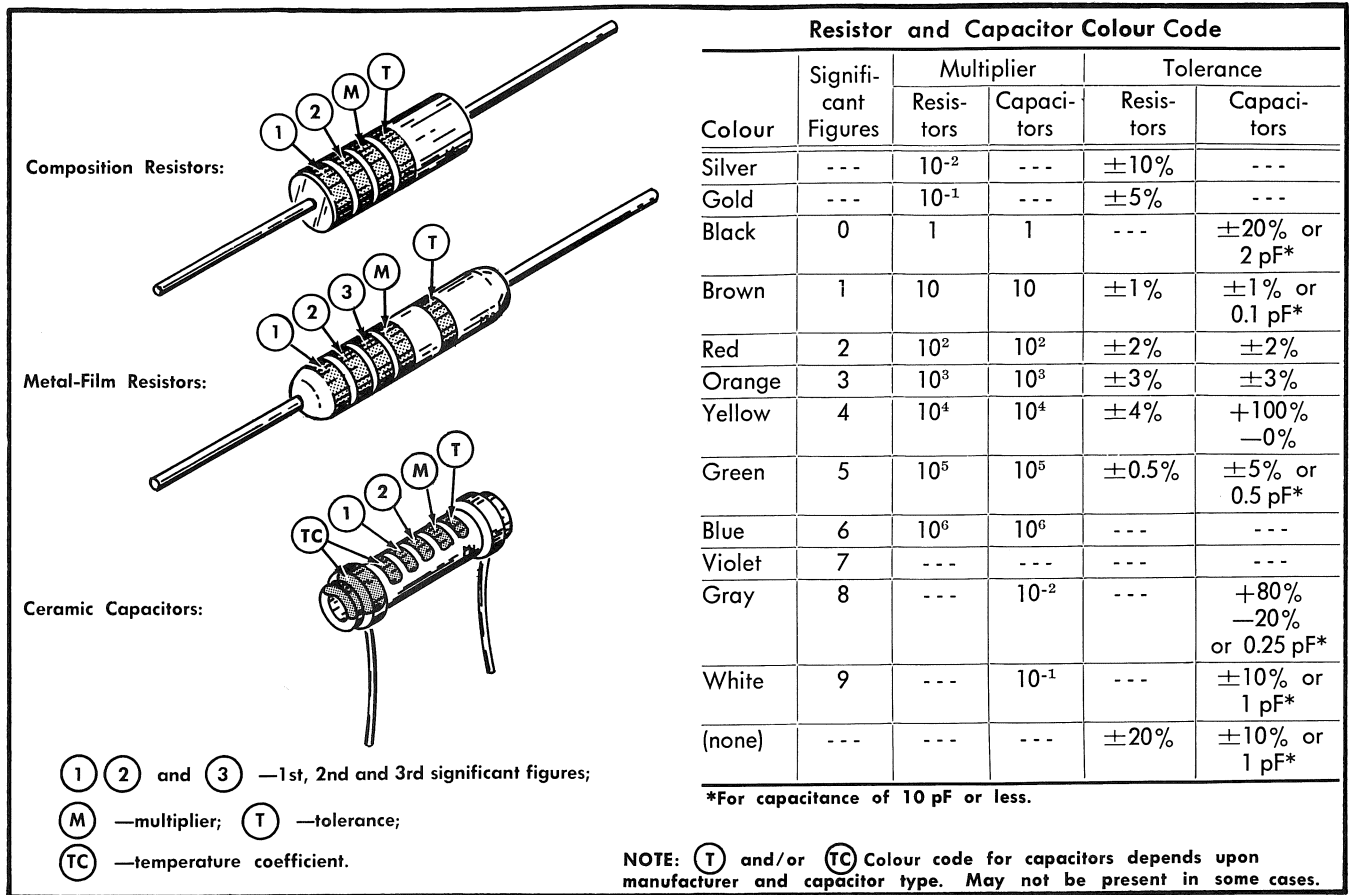

Fig. 4-3. Standard EIA colour coding for resistors and capacitors.

**NOTE**

This instrument may be checked with a VTVM having a 10 megohm input impedance and a 0 to 30-volt range DC, 0 to 150-volt range AC. To measure power supply voltages, the meter needs accuracy with 0.3%. Accuracy within 3% is adequate for other circuit voltage readings. The ohmmeter needs a range of 0 to 50 megohms.

Purpose: To check voltages and for general troubleshooting in this instrument.

**3. Test Oscilloscope**

Description: DC to 10 MHz frequency response (signal tracing). 10 millivolts to 10 volts/division deflection factor using a 10X probe.

Purpose: To check waveforms in this instrument.

**Troubleshooting Techniques**

This troubleshooting procedure is arranged in an order which checks the simple possibilities before proceeding with extensive troubleshooting. The first few checks assure proper connection, operation and calibration. If the trouble is not located by these checks, the remaining steps aid in locating the defective component. When the defective component is

located, it should be replaced following the replacement procedure given under Corrective Maintenance.

**1. Check Control Settings.** Incorrect control settings can indicate trouble that does not exist. If there is any question about the correct function or operation of any control, see the Operating Instructions.

**2. Check Associated Equipment.** Before proceeding with troubleshooting of the Type R141A, check that the equipment used with this instrument is operating correctly. Check that the signal is properly connected and that the interconnecting cables are not defective. Also, check the power source.

**3. Visual Check.** Visually check the portion of the instrument in which the trouble is located. Many troubles can be located by visual indications, such as unsoldered connections, loose pin connectors, broken wires, damaged circuit boards, damaged components, etc.

**Check Instrument Calibration.** Check the calibration of this instrument, or the affected circuit if the trouble exists in one circuit. The apparent trouble may only be a result of misadjustment and may be corrected by calibration. Complete calibration instructions are given in the Performance Check/Calibration section.

**5. Isolate Trouble to a Circuit.** To isolate trouble to a circuit, note the trouble symptoms. The symptoms often

TABLE 4-4

## Power Supply Voltages and Approximate Resistances

Power Supply	Test Point	Tolerance	Type of Meter: Triplett			Type of Meter:		
			'Model: 630-NA			Model:		
			Instrument Type: R141A			Instrument Type:		
			Serial No.:			Serial No.:		
Resistance Measurement		Ohms Range Used	Resistance Measurement		Ohms Range Used			
+ Lead	— Lead		+ Lead	— Lead				
—15 V	Y	±3%	180 Ω	220 Ω	×100			
+3.6 V	AG	±3%	240 Ω	150 Ω	×100			
+10 V	AF	±3%	250 Ω	200 Ω	×100			

identify the circuit in which the trouble is located. For example, if one luminance step in the composite video staircase signal is absent, this indicates that the Staircase Luminance Amplifier circuit is probably at fault. When trouble symptoms appear in more than one circuit, check affected circuits by taking voltage and waveform readings.

Incorrect operation of all circuits often indicates trouble in the power supply. Check first for correct voltage of the individual supplies. A defective component elsewhere in the circuit can also appear as a power-supply trouble, and affect the operation of other circuits. Table 4-4 lists the tolerance of the power supplies in this instrument when measured at the test points given in the table. Fig. 4-4 shows the locations of these test points and the ground connection for the VOM common lead. If a power supply voltage is within the listed tolerance, the supply can be assumed to be working correctly. If outside the tolerance, the supply may be misadjusted or operating incorrectly. Use the procedure given in the Calibration section to adjust the power supplies.

Table 4-4 also lists the approximate power supply resistances when measured between each of the power supply test points and ground (pin connector × on the Power Supply board). Two resistance measurements are given: (1) With the + (positive polarity) lead of the VOM connected to the power supply test point, and (2) with the — (negative polarity) lead connected to the same power supply test point. Since these measurements are not absolute and may vary considerably between instruments and because of the type of ohmmeter used, space is provided in the table for filling in the information that pertains to a particular instrument and ohmmeter.

Fig. 3-1 through 3-4 in the Circuit Description section can be used as a guide for isolating a trouble. These illustrations are functional block diagrams that show how the various signal components are combined to form the composite video signal. By using the front-panel controls and checking the signals at the BNC connectors, it is possible to determine the blocks or circuits that are functioning properly and those that do not.

When a trouble is isolated to the smallest possible area, proceed with steps 6 through 8 in this troubleshooting procedure to locate the defective component(s).

**6. Check Circuit Board Interconnections.** After the trouble has been isolated to a particular area or circuit, check the pin connectors on the circuit board for correct connection. Figs. 4-6 through 4-15 show the correct connections for each board.

The pin connectors used in this instrument also provide a convenient means of circuit isolation. For example, a short in a power supply can be isolated to the power supply itself by disconnecting the power distribution pin connectors for the voltage at the Power supply board when making resistance to ground checks.

**7. Check Voltage and Waveforms.** Often the defective component can be located by checking for the correct voltage or waveform in the circuit. Typical voltages and waveforms are given on the diagrams.

## NOTE

Voltages and waveforms given on the diagrams are not absolute and may vary slightly between instruments. To obtain operating conditions similar to those used to take these readings, see the inside portion of the Subcarrier Oscillator and Output diagram pull-out page.

## CAUTION

Due to the component density on the circuit boards, care should be taken with meter leads and probe tips. Accidental shorts can cause abnormal voltages or transients which may destroy many components.

## WARNING

"Ground lugs" are not always at ground potential. Check the schematic before using such connections as a ground for the voltmeter test prod or oscilloscope probe. Some transistor cases may be elevated.

**8. Check Individual Components.** The following procedures describe methods of checking individual components in the Type R141A. Components which are soldered in place are best checked by disconnecting one end. This isolates the measurement from the effects of surrounding circuitry.

A. TRANSISTORS (excluding FETs). The best check of transistor operation is actual performance under operating conditions. If a transistor is suspected of being defective, it can best be checked by substituting a new transistor or one which has been checked previously. However, be sure that circuit conditions are not such that a replacement transistor might also be damaged. If substitute transistors are not available, use a dynamic tester (such as Tektronix Type 576).

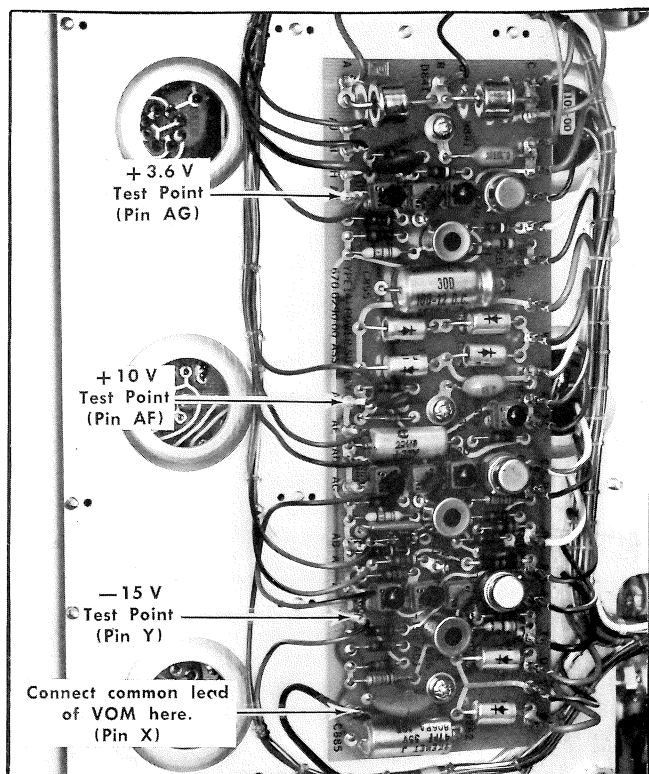

Fig. 4-4. Power Supply board test point locations.

Static-type testers are not recommended, since they do not check operation under simulated operating conditions.

**B. FET and IC Replacement.** FETs and ICs should not be replaced unless they are actually defective. The best method for checking these devices is by direct substitution. Be sure the voltage conditions of the circuit are not such that the replacement component might also be damaged.

**C. DIODES.** A diode can be checked for an open or shorted condition by measuring the resistance between terminals. With an ohmmeter scale having an internal source of between 800 millivolts and 3 volts, the resistance should be very high in one direction and very low when the leads are reversed.

**CAUTION**

Do not use an ohmmeter scale that has a high internal current. High current may damage the diode.

**D. RESISTORS.** Check the resistors with an ohmmeter. Check the Electrical Parts List for the tolerances of the resistors used in this instrument. Resistors normally do not need to be replaced unless the measured value varies widely from the specified value.

**E. INDUCTORS.** Check for open inductors by checking continuity with an ohmmeter. Shorted or partially shorted inductors can usually be found by checking the waveform response when high-frequency signals are passed through the circuit. Partial shorting often reduces high-frequency response (roll-off).

**F. CAPACITORS.** A leaky or shorted capacitor can best be detected by checking resistance with an ohmmeter on the highest scale. Do not exceed the voltage rating of the capacitor. The resistance reading should be high after initial charge of the capacitor. An open coupling capacitor can best be detected with a capacitance meter or by checking whether the capacitor passes AC signals.

**G. POWER INPUT CONNECTOR AND RFI FILTER.** This item is replaceable as a unit and repair should not be attempted. If it is necessary to replace this unit, be sure to observe polarity to assure protection for the instrument. The narrow blade (terminal 4) should show continuity to terminal 3 which connects to fuse F2. The filter contains an internal non-replaceable fuse between terminals 4 and 3. Use care when soldering to terminals 1 and 3, as excess solder could cause a short to the filter case.

**9. Repair and Readjust the Circuit.** If any defective parts are located, follow the replacement procedure given in this section. Be sure to check the performance of any circuit that has been repaired or that has had any electrical components replaced.

**Power Cord Conductor Identification**

Conductor	Color	Alternate Color
Ungrounded (Line)	Brown	Black
Grounded (Neutral)	Blue	White
Grounding (Earthing)	Green-Yellow	Green-Yellow

**REPACKAGING FOR SHIPMENT**

If the Tektronix instrument is to be shipped to a Tektronix Service Center for service or repair, attach a tag showing: owner (with address) and the name of an individual at your firm that can be contacted, complete instrument serial number and a description of the service required.

Save and re-use the package in which your instrument was shipped. If the original packaging is unfit for use or not available, repackage the instrument as follows:

Surround the instrument with polyethylene sheeting to protect the finish of the instrument. Obtain a carton of corrugated cardboard of the correct carton strength and having inside dimensions of no less than six inches more than the instrument dimensions. Cushion the instrument by tightly packing three inches of dunnage or urethane foam between carton and instrument, on all sides. Seal carton with shipping tape or industrial stapler.

The carton test strength for your instrument is 275 pounds.

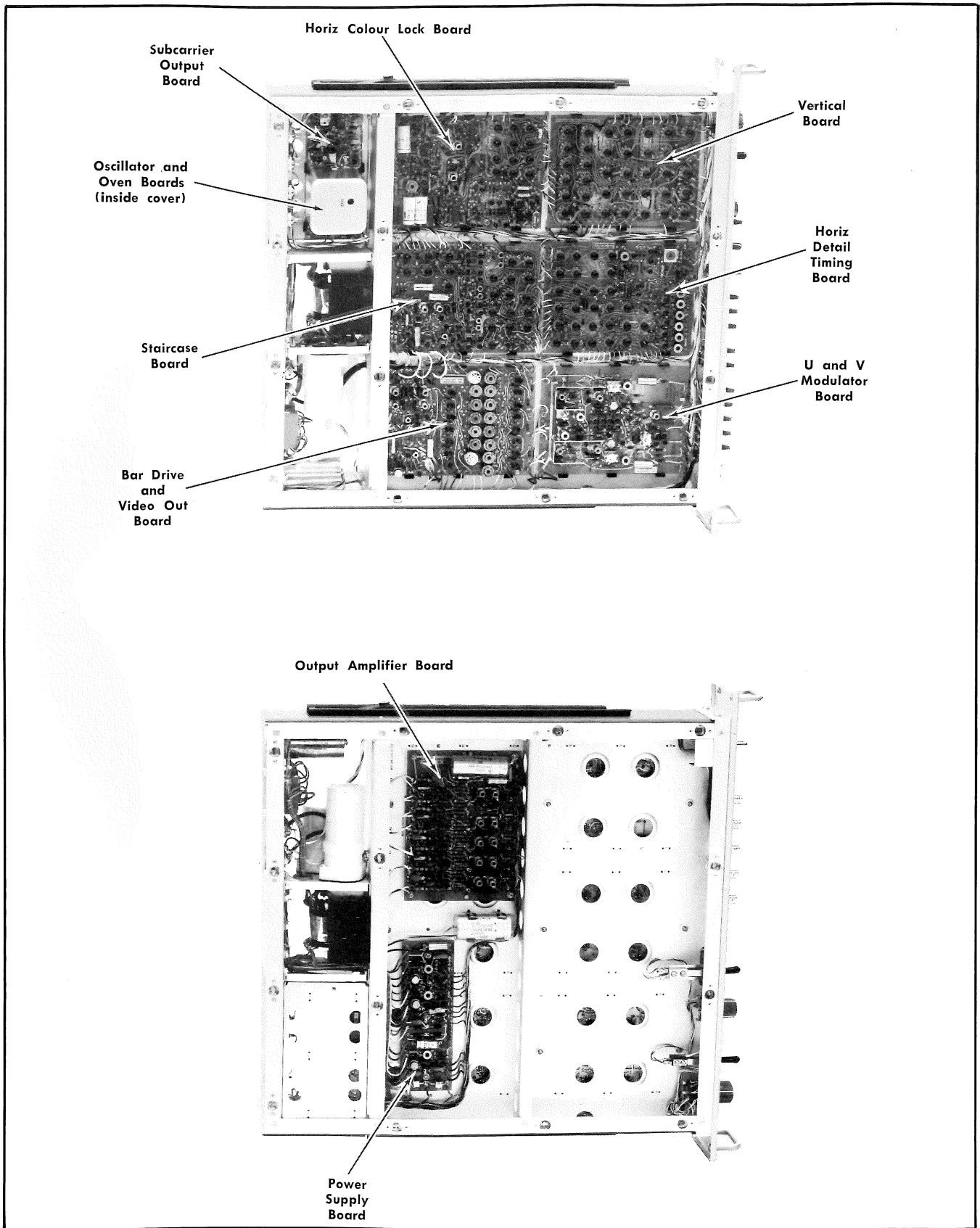

Fig. 4-5. Location of circuit boards in the Type R141A.

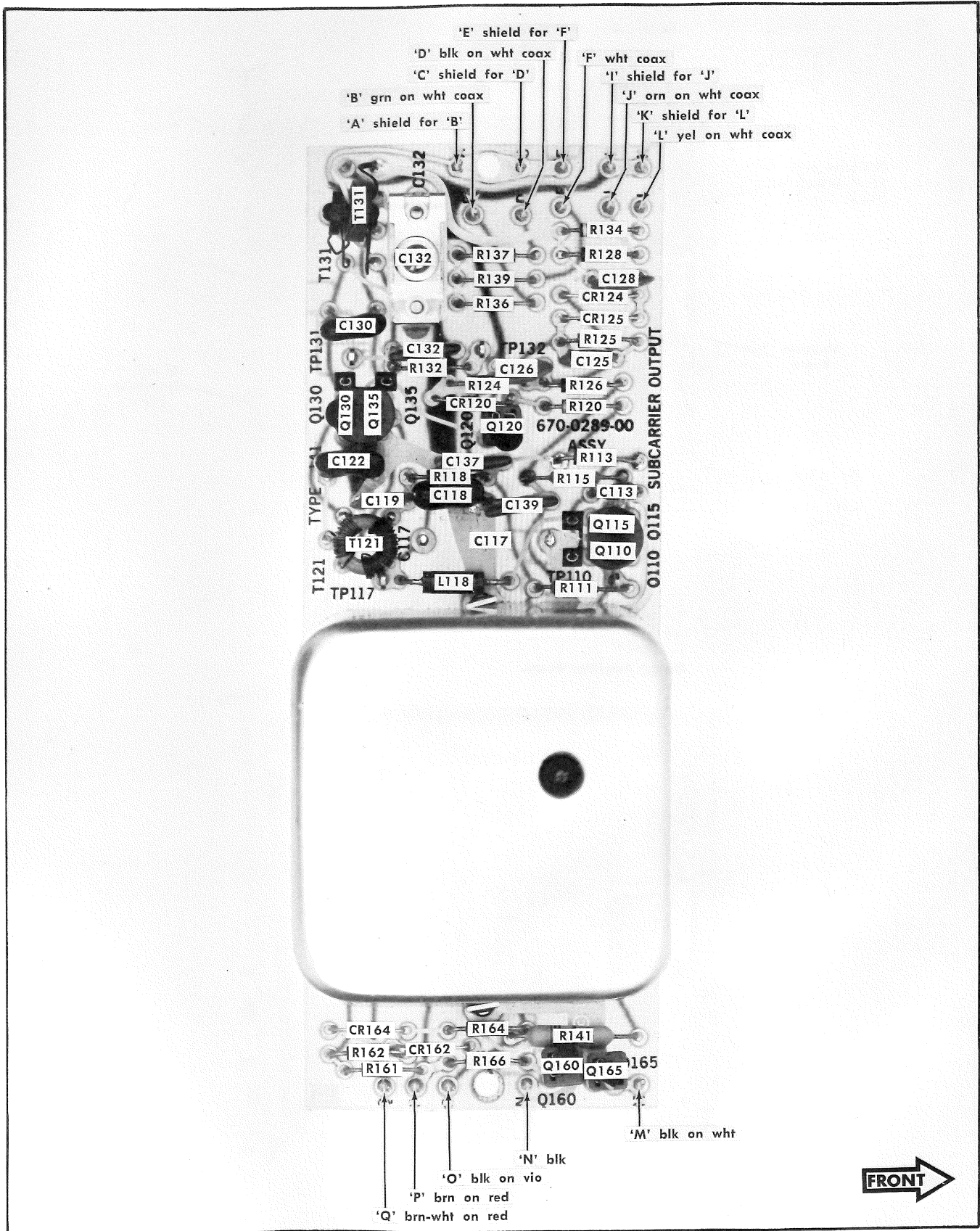

Fig. 4-6. Subcarrier Output board; component identification and wire colour code.



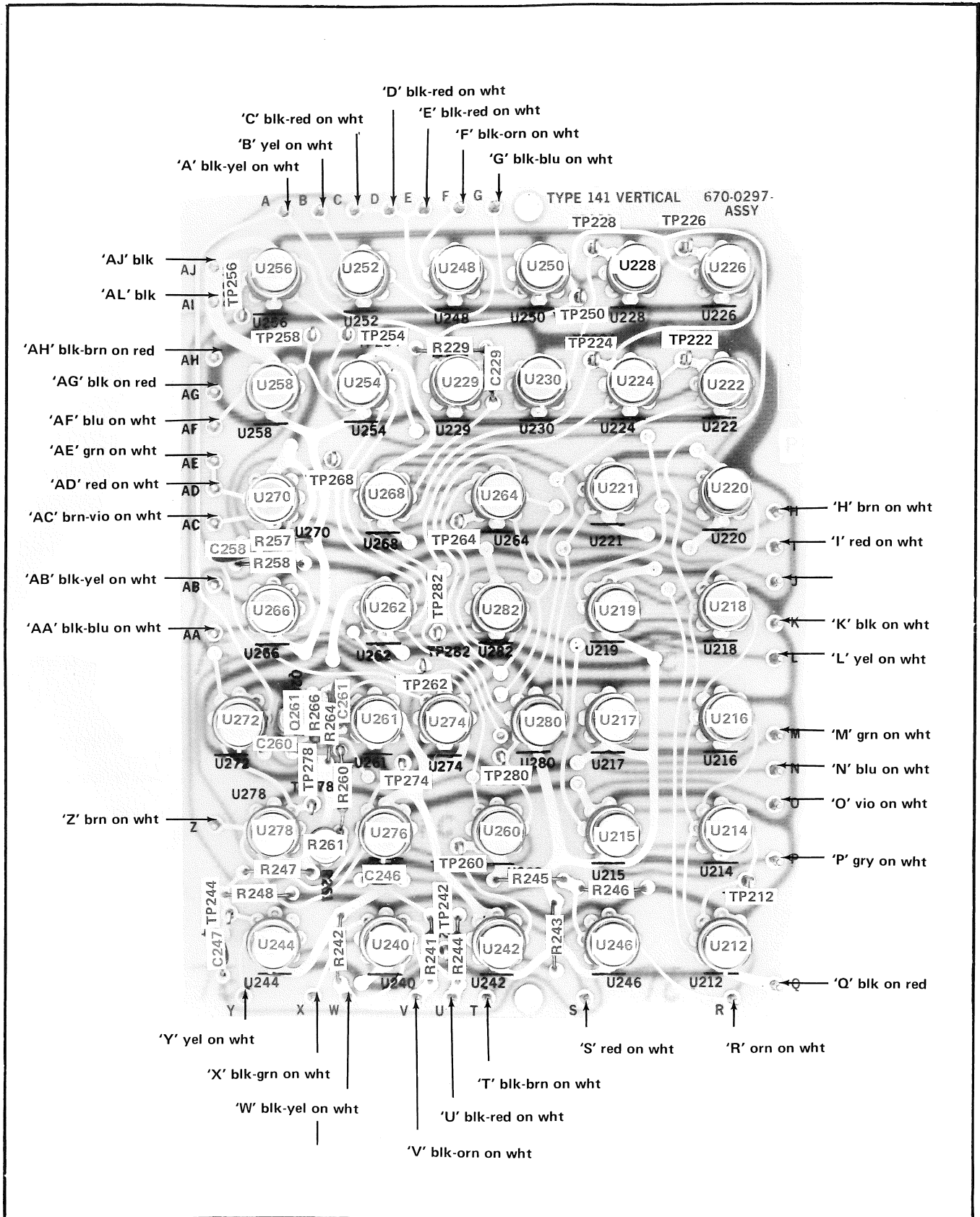

Fig. 4-7A. Vertical board; component identification and wire colour code SN B130000 and above.

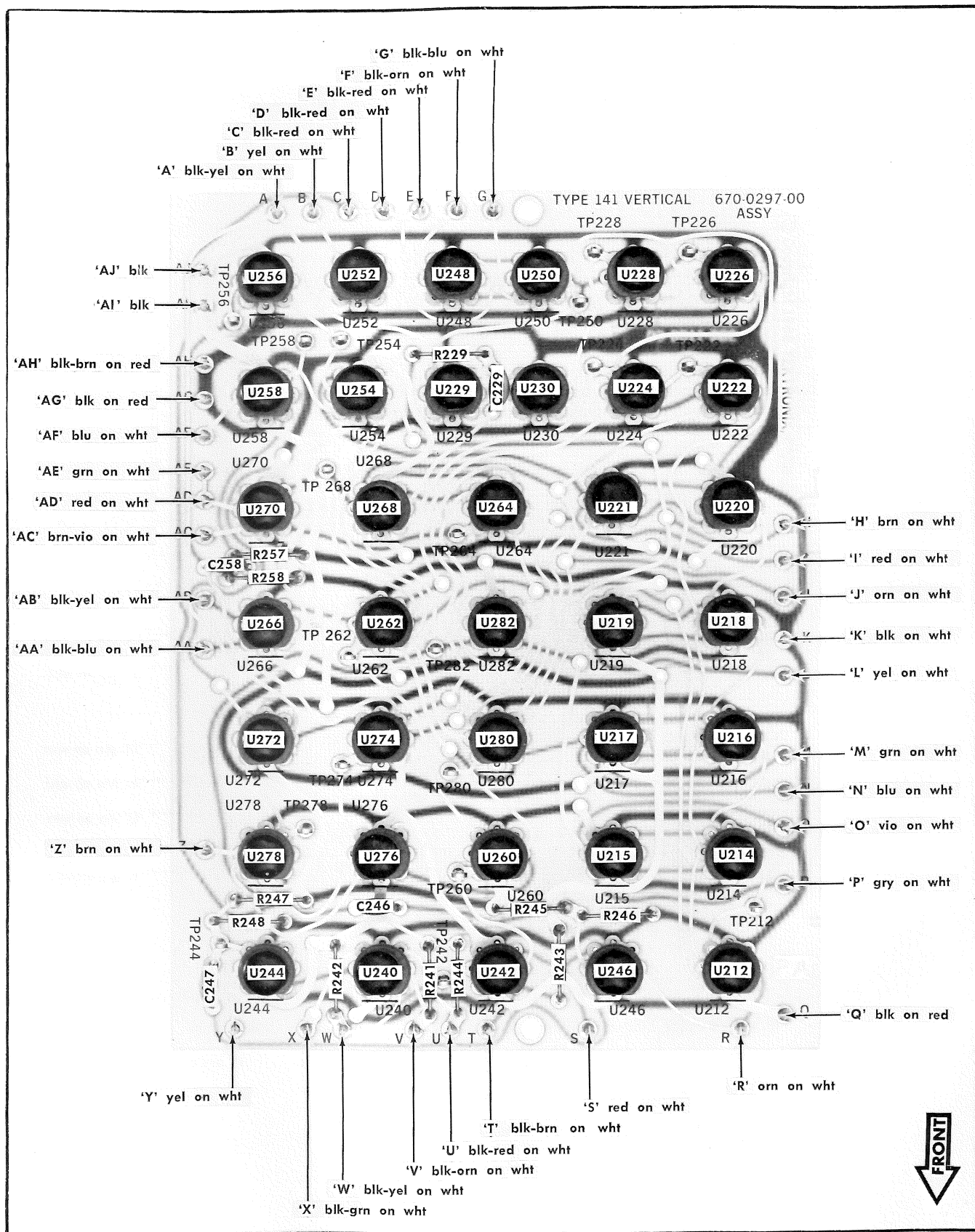

Fig. 4-7B. Vertical board; component identification and wire colour code below SN B130000.



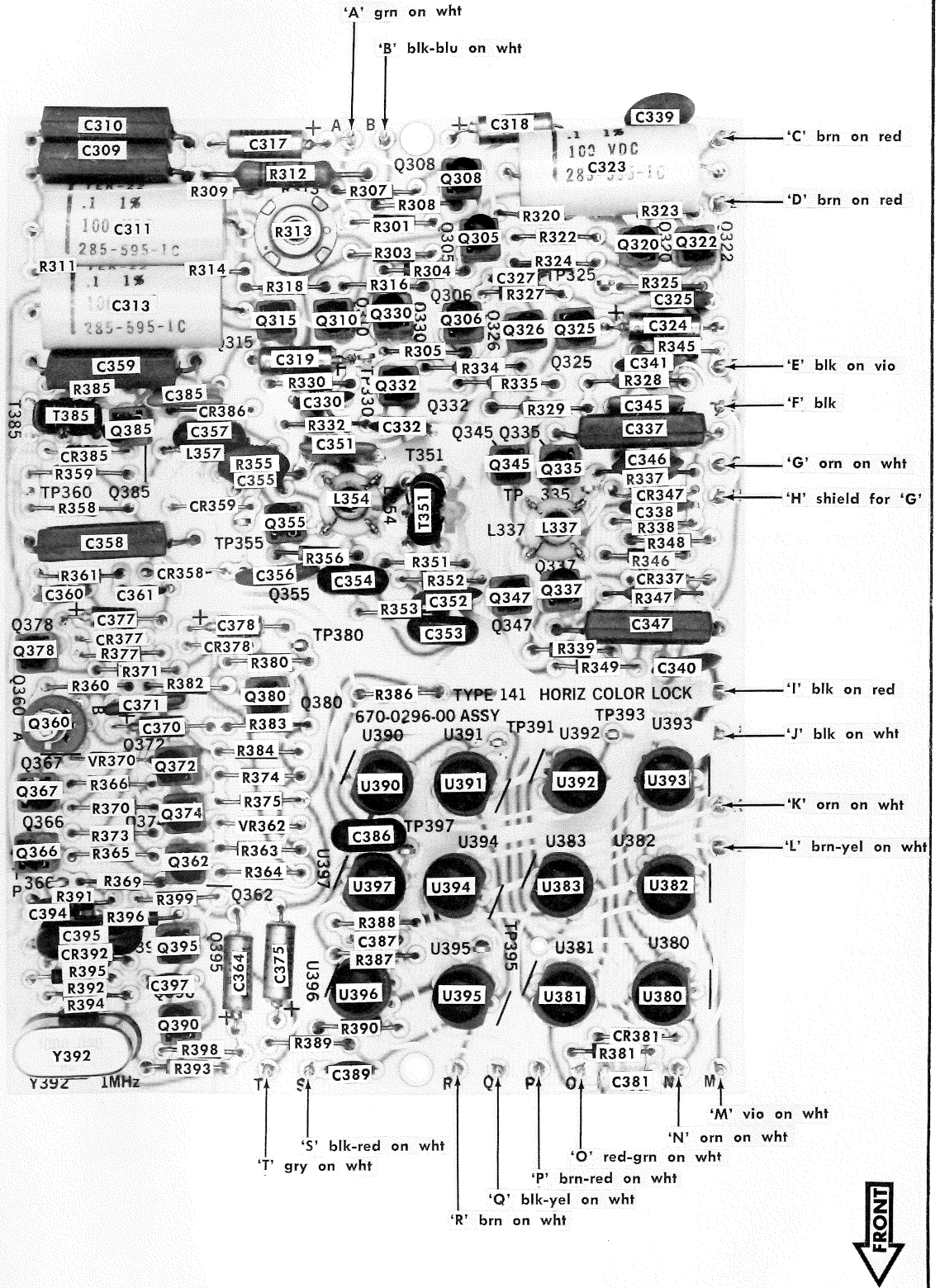

Fig. 4-8. Horiz Colour Lock board; component identification and wire colour code.

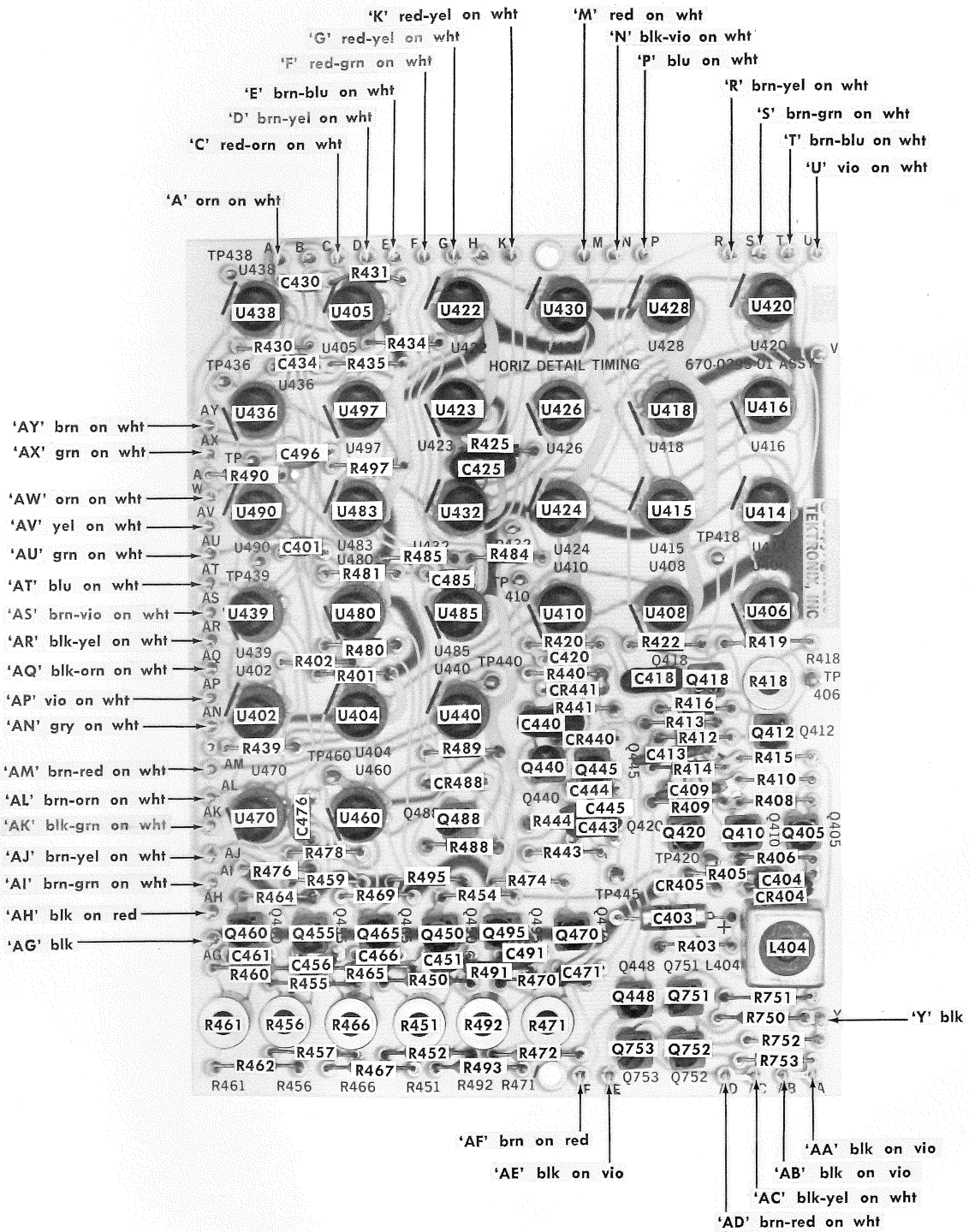

Fig. 4-9. Horiz Detail Timing board; component identification and wire colour code.

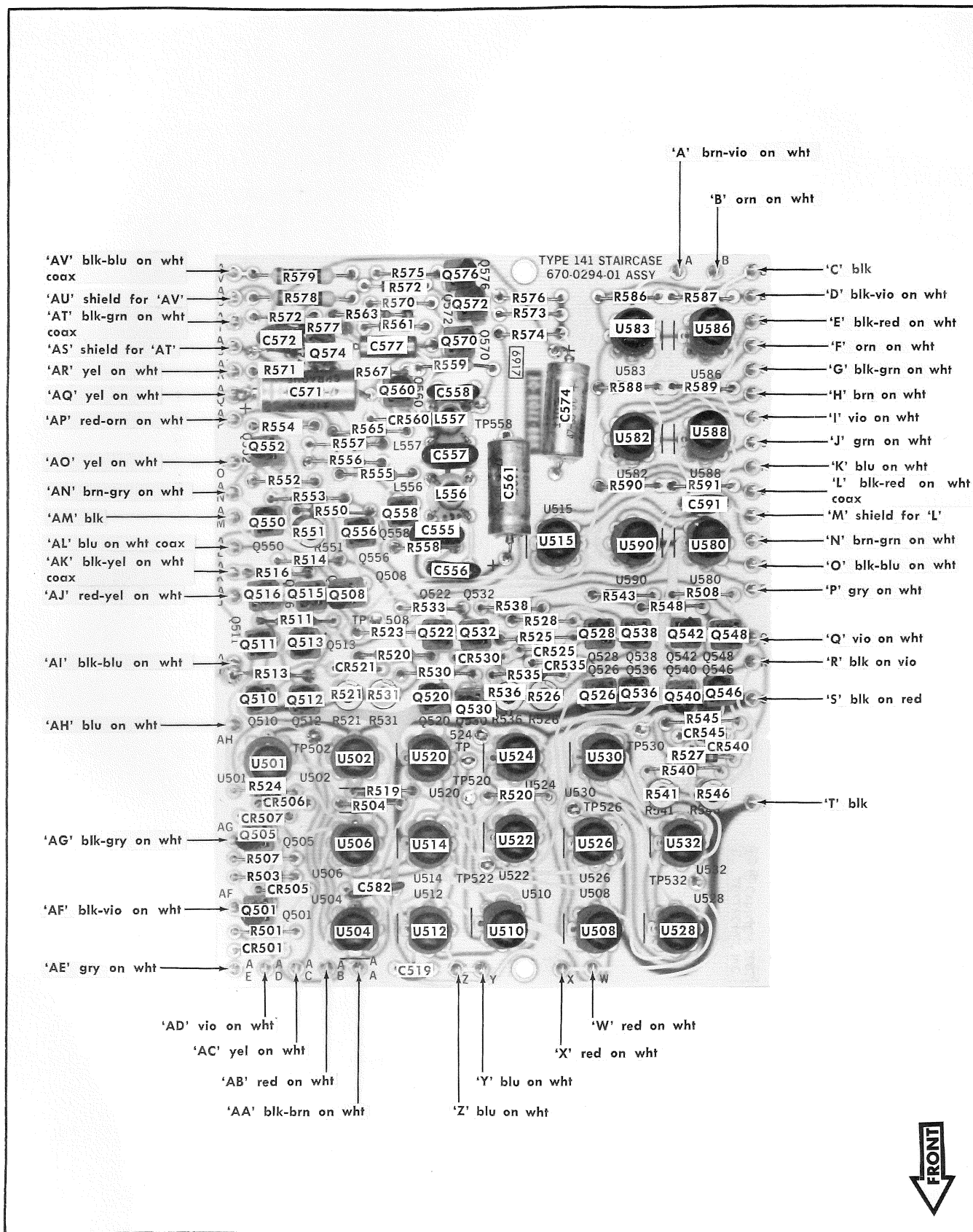

Fig. 4-10. Staircase board; component identification and wire colour code.

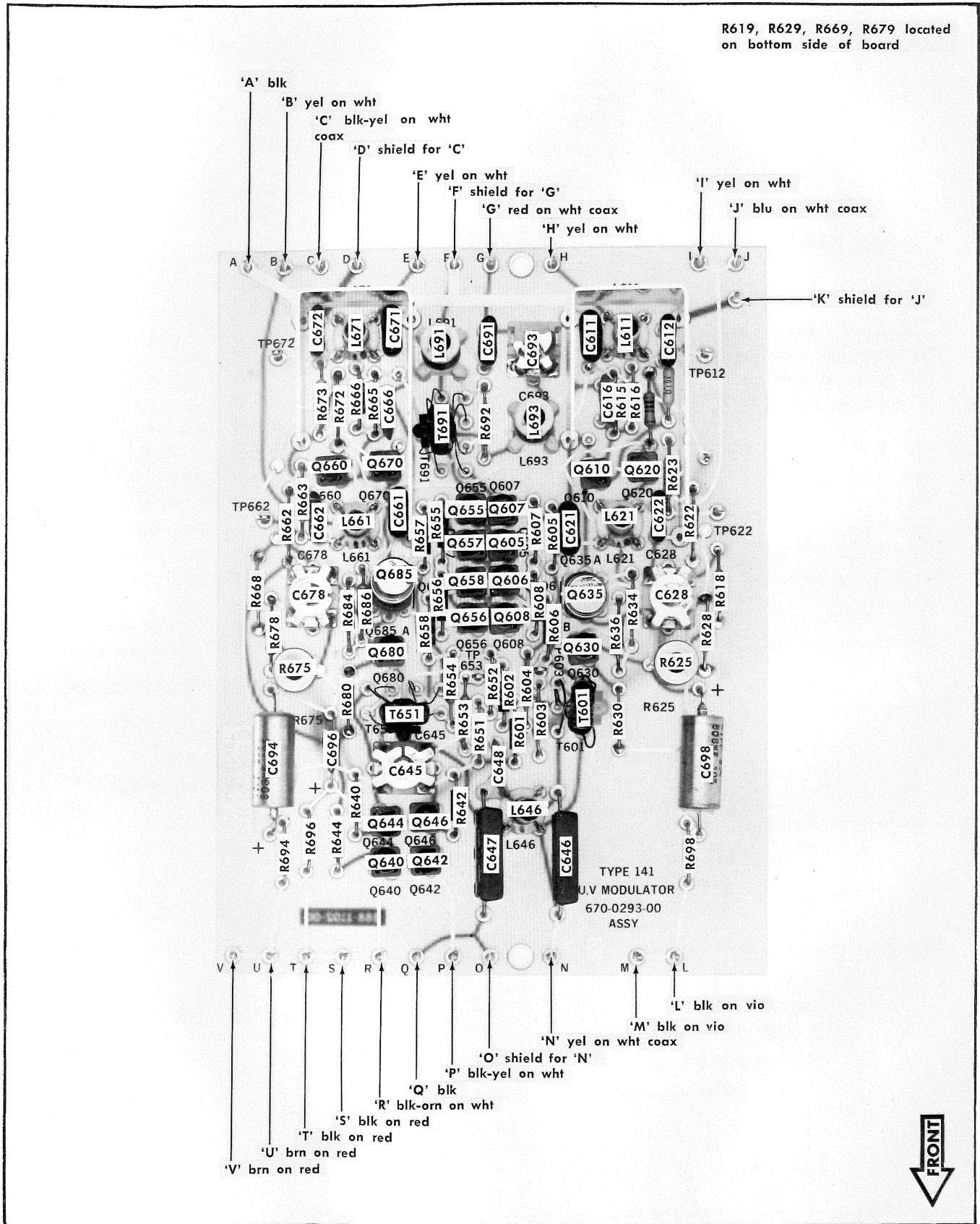

Fig. 4-11. U and V Modulator board; component identification and wire colour code.



R700, R707, C707, R711, R777 and R780 located on bottom side of board.

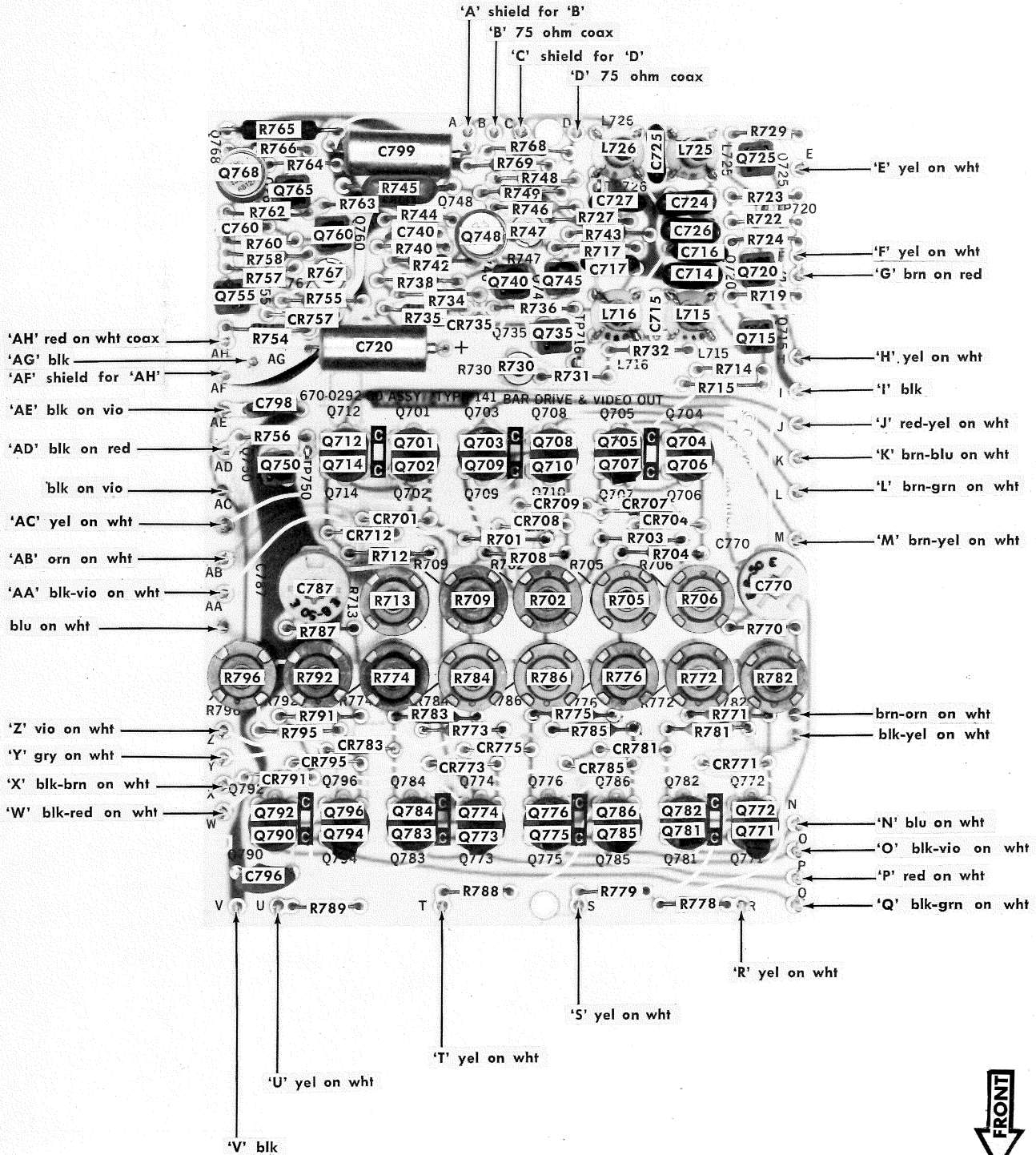

Fig. 4-12. Bar Drive and Video Out board; component identification and wire colour code.

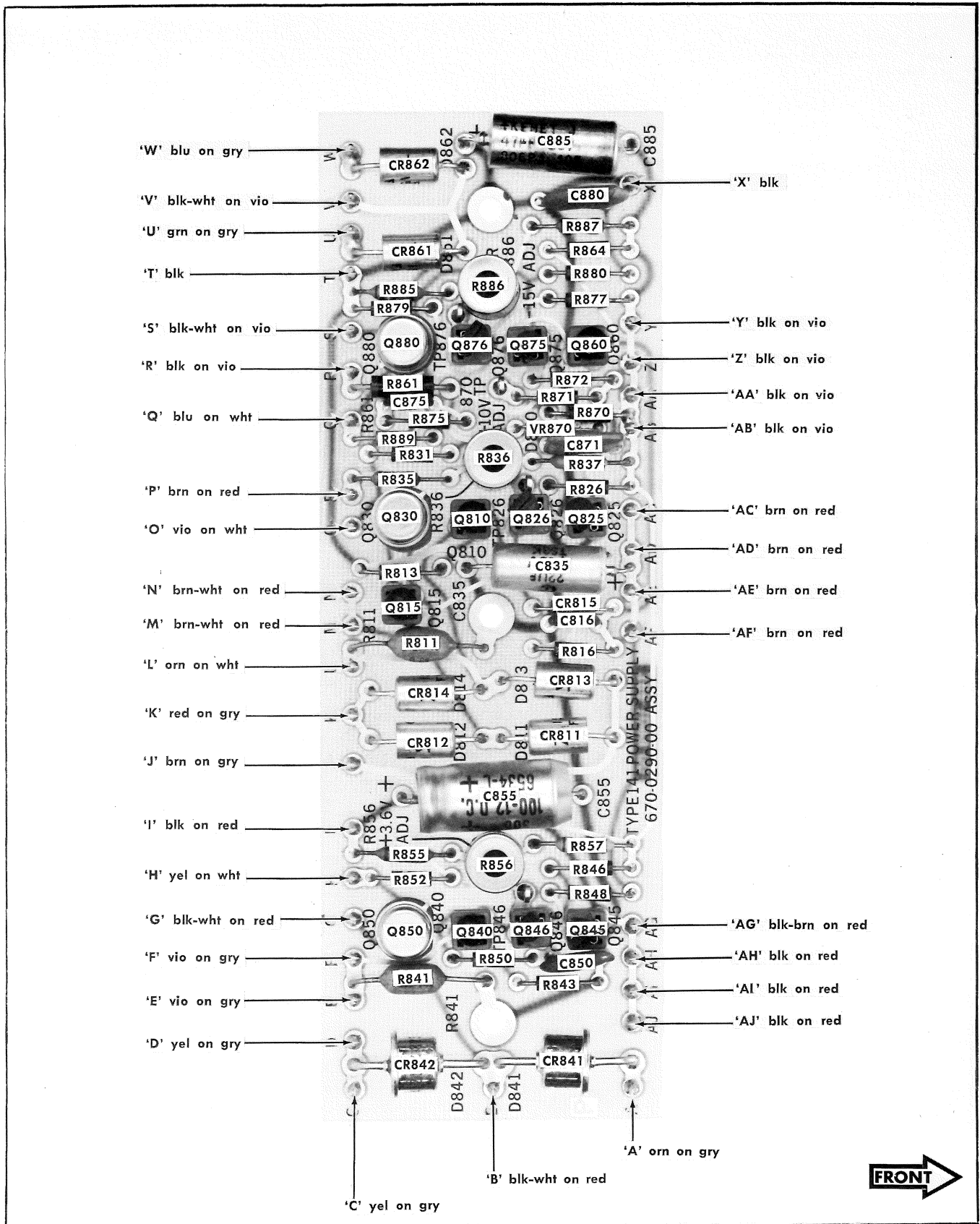

Fig. 4-13. Power Supply board; component identification and wire colour code.

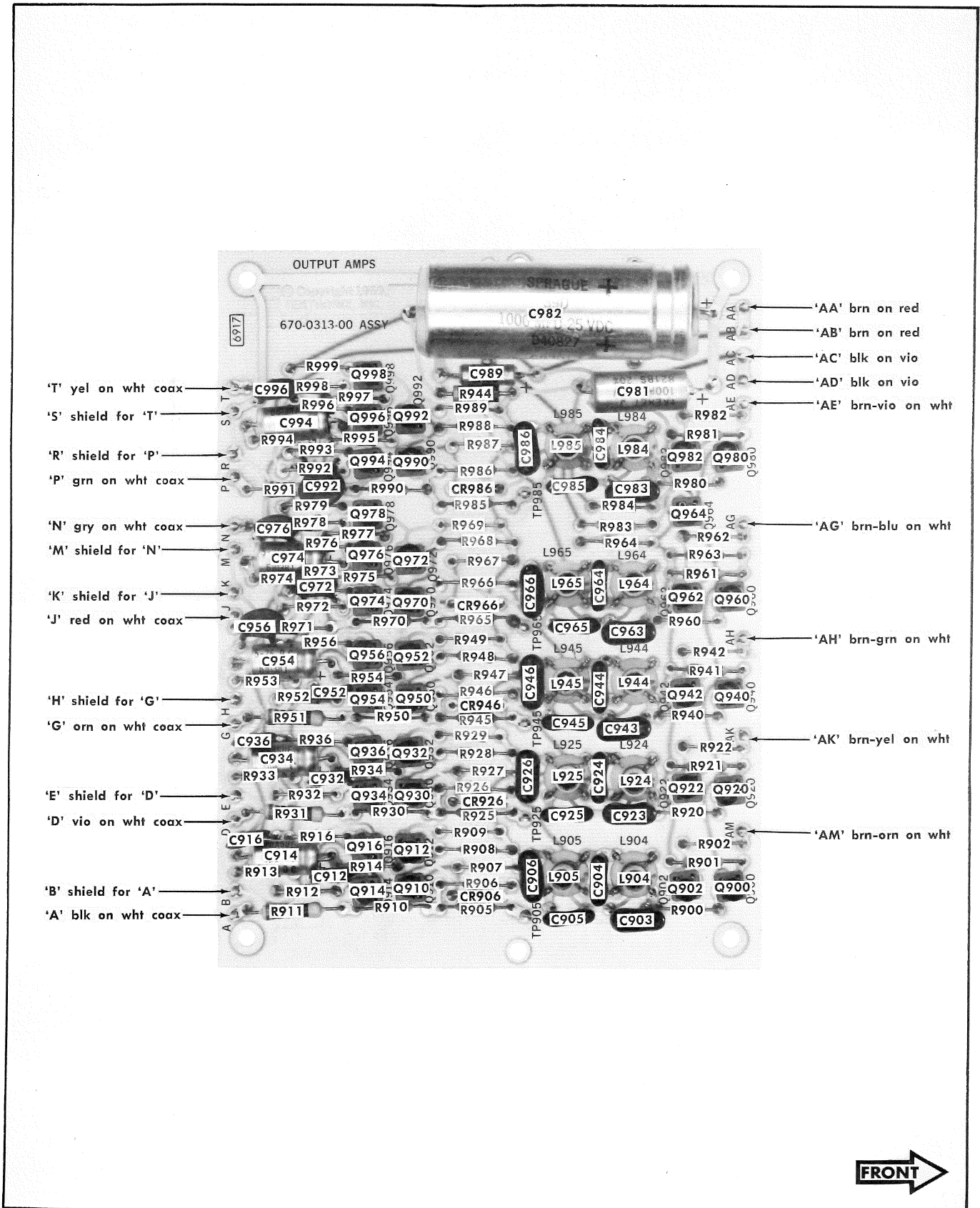

Fig. 4-14. Output Amplifier board; component identification and wire colour code.

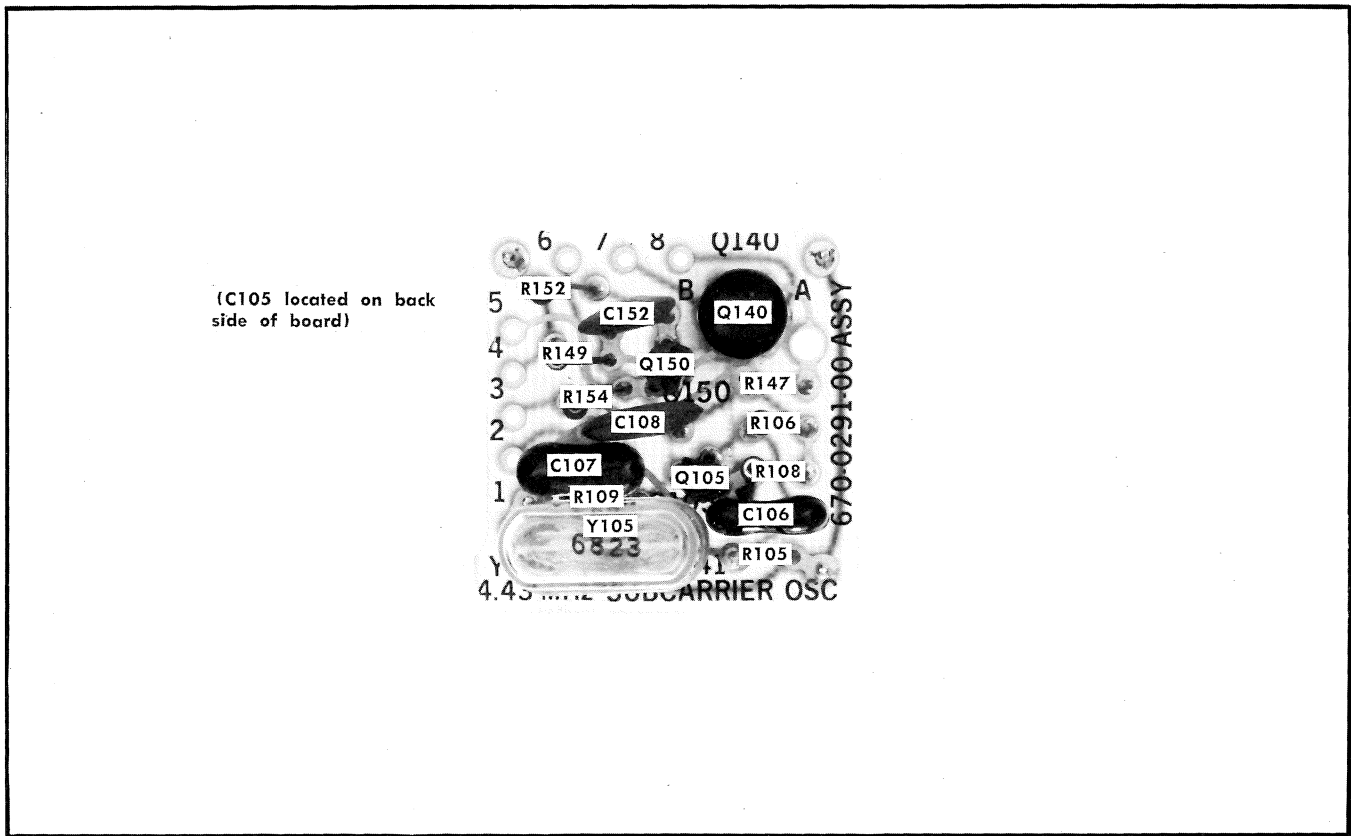

Fig. 4-15. Oscillator board; component identification.



# SECTION 5

## PERFORMANCE CHECK / CALIBRATION

Change information, if any, affecting this section will be found at the rear of the manual.

### Introduction

This procedure checks and/or calibrates the instrument to the performance requirements listed in the Specification section. Limits, tolerances, and waveforms in this section are given as calibration guides and are not instrument specifications. The instrument should not require frequent calibration, but on occasional adjustment will be necessary when transistors, integrated circuits, and other components are changed. Also, a periodic recalibration is desirable from the standpoint of preventive maintenance. The calibration of the instrument should be checked after every 1000 hours of operation or after each six months period if the instrument is used intermittently.

### TEST EQUIPMENT REQUIRED

#### General

All of the following test equipment, or its equivalent, is required for complete calibration of the Type R141A. Test equipment used is illustrated in the setup pictures for related steps in the procedure.

Specifications given are the minimum necessary for accurate calibration. All test equipment is assumed to be correctly calibrated and operating within the given specifications. If equipment is substituted, it must meet or exceed the specifications of the recommended equipment.

For ease and accuracy in calibration, special calibration fixtures are used where necessary. All calibration fixtures listed are available from Tektronix, Inc. Order by part number through your local Tektronix Field Office or representative.

#### Equipment List

1. Precision Digital Voltmeter. Accuracy, within  $\pm 0.1\%$ ; range, 3 to 15 volts. For example, Fairchild Model 7050.
2. DC Voltmeter (VOM). Minimum sensitivity, 20,000 ohms/volt; accuracy, checked to within  $\pm 3\%$  at 3.6 V. For example, Triplett Model 630 NA.
3. Test Oscilloscope. Bandwidth, DC to at least 30 MHz; minimum deflection factor, 1 mV/division; DC offset voltage, 0 to 1 volt; two input channels providing choice of independent channel operation or differential operation; sweep magni-

fication, X100. A Tektronix Type 547 Oscilloscope with a Type 1A5 Plug-In Unit was used for the Performance Check/Calibration procedure.

4. Variable Autotransformer. Must be capable of supplying at least 200 volt-amperes over a voltage range of 90 to 136 volts (180 to 272 volts for 230-volt nominal line). If autotransformer does not have an AC Voltmeter to indicate output voltage, monitor output with an AC voltmeter (RMS) with a range of at least 136 (or 272) volts. For example, General Radio W10MT3W Metered Variac Autotransformer.

5. Vectorscope. Measuring functions, differential gain and phase; accuracy, 0.5% and  $0.1^\circ$  respectively. Tektronix Type 520 or R520 Mod 188P PAL Vectorscope recommended.

6. Constant Amplitude Signal Generator. Frequency, 5 MHz; output amplitude, adjustable from about 0.5 volt to 2 volts; amplitude regulation within  $\pm 3\%$ . Tektronix Type 191 Constant Amplitude Signal Generator recommended.

7. Electronic Digital Frequency Counter. Frequency measurement, DC to 5 MHz. For example, Hewlett-Packard Model 5245L Electronic Counter.

8. 067-0596-00 Chopped Voltage Reference.<sup>1</sup> Tektronix calibration fixture 067-0596-00 recommended.

9. 011-0109-00 Voltage Step Up Termination. Tektronix Part No. 011-0109-00.

10. 067-0576-00 Return Loss Bridge. Tektronix calibration fixture 067-0576-00 recommended.

11. Probe. Attenuation,  $10\times$ ; connector, BNC. Tektronix Probe P6008 Part No. 010-0219-00 recommended (supplied with Tektronix Type 547 Oscilloscope).

12. Probe. Attenuation,  $1\times$ ; connector, BNC. Tektronix Probe P6028 recommended. Tektronix Part No. 010-0074-00.

13. Cable (three). Impedance, 75 ohm; length, 42 inches; connectors, BNC. Tektronix Part No. 012-0074-00.

14. Cable. Impedance, 50 ohm; length, 5 ns; connectors, GR. Tektronix Part No. 017-0502-00 (supplied with Tektronix Type 191).

15. Termination (three). Impedance, 75 ohm; connector, BNC; type, end-line; accuracy,  $\pm 3\%$ . Tektronix Part No. 011-0102-00.

<sup>1</sup>See "Note" following Step 6 (O) of procedure.

## Performance Check/Calibration—Type 141A/R141A

16. Termination. Impedance, 75 ohm; connector, BNC; type; feed-thru; accuracy, within 0.2%. Tektronix Part No. 011-0103-02 (supplied with Tektronix Type 141A/R141A).

17. Termination (two). Impedance, 75 ohm; connectors, BNC; type, feed-thru; accuracy, matched to within 0.2%. Tektronix Part No. 011-0103-00 and 011-0103-01 (supplied with Tektronix 067-0576-00 calibration fixture).

18. Adapter. Connectors, BNC Male to GR; Tektronix Part No. 017-0064-00.

19. Attenuator. Impedance, 50 ohm to 75 ohm; connectors, BNC; type, minimum loss going from a 50 ohm system to a 75 ohm system. Tektronix Part No. 011-0057-00.

### 20. Adjustment tools

Description	Tektronix Part No.
a. Tuning tool:	
Handle; nylon	003-0307-00
Insert; 0.077-inch outside diameter, for 5/64-inch inside hex cores.	003-0310-00
b. Rod; 5 inches long, plastic, for 0.100 inch inside diameter powered iron hex cores.	003-0301-00
c. Adjustment tool; 1 1/2-inch shaft, 5 inches total length, plastic shaft and handle, and metal screwdriver tip.	003-0000-00
d. Screwdriver; 3/32-inch bit width, 3/32 inch diameter round shank, 5 inches long with plastic handle.	003-0192-00

## CALIBRATION RECORD AND INDEX

This short-form procedure is provided to aid in checking the calibration of the Type R141A. It may be used as a calibration guide by the experienced calibrator, or it may be used as a record of calibration. Since the step numbers and titles correspond to those in the complete procedure, this procedure also serves as an index to the complete Calibration Procedure. Performance requirements correspond to those given in the Specification section.

### SHORT FORM CALIBRATION PROCEDURE

- |   |                                      |
|---|--------------------------------------|
| <input type="checkbox"/> 1. Adjust Regulated Power Supplies                               | Page 5-6                             |
| Requirements: -15 Volts ..... ±3%   |                                      |
| +3.6 Volts ..... ±3%  |                                      |
| +10 Volts ..... ±3%   |                                      |
| <input type="checkbox"/> 2. Check Power Supply Regulation and Ripple                      | Page 5-6                             |
| Regulation  | Requirement: See complete procedure. |
| Ripple  |                                      |
| Requirements: -15 Volts ..... ≤ 50 mV peak to peak.                                       |                                      |
| +3.6 Volts ..... ≤ 100 mV peak to peak.   |                                      |
| +10 Volts ..... ≤ 50 mV peak to peak.   |                                      |
| <input type="checkbox"/> 3A. Check/Adjust Subcarrier Oscillator Frequency                 | Page 5-9                             |
| Requirement: 4.43361875 MHz, ±5 Hz.   |                                      |
| <input type="checkbox"/> 3B. (Alternate Procedure) Adjust Subcarrier Oscillator Frequency | Page 5-9                             |
| Requirement: See complete procedure.  |                                      |
| <input type="checkbox"/> 4. Check/Adjust Subcarrier Amplitude                             | Page 5-10                            |
| Requirement: 2 volts peak to peak within 0.2 V  |                                      |
| <input type="checkbox"/> 5. Check Subcarrier Channel Isolation                            | Page 5-11                            |
| Requirement: greater than or equal to 30 dB.  |                                      |
| <input type="checkbox"/> 6. Check/Adjust Luminance Amplifier Gain                         | Page 5-13                            |
| Requirement: Blanking level to peak white (700 mV within 1%).                             |                                      |
| <input type="checkbox"/> 7. Check/Adjust Sync Amplitude                                   | Page 5-14                            |
| Requirement: Blanking level to sync tip (-300 mV within 1%).                              |                                      |
| <input type="checkbox"/> 8. Check/Adjust Luminance Amplifier DC Balance                   | Page 5-15                            |
| Requirement: Blanking level must be at 0 volts within 0.1 V.                              |                                      |
| <input type="checkbox"/> 9. Check Variable APL Amplitudes                                 | Page 5-15                            |
| Requirement: 0 to 700 mV in 10 equal increments within 2%.                                |                                      |
| <input type="checkbox"/> 10. Check/Adjust Chroma Bar Width                                | Page 5-16                            |
| Requirement: Black bar width must be 6.5 μs within 5%.                                    |                                      |
| <input type="checkbox"/> 11. Adjust U and V Modulator Filters                             | Page 5-19                            |
| Requirement: See complete procedure.  |                                      |
| <input type="checkbox"/> 12. Check/Adjust U and V Quad Phase and Carrier Balance          | Page 5-20                            |
| Requirement: See complete procedure.  |                                      |
| <input type="checkbox"/> 13. Check/Adjust U-V Quad Phase                                  | Page 5-20                            |
| Requirement: Colour bars must overlay.  |                                      |
| <input type="checkbox"/> 14. Check/Adjust 180° Switcher                                   | Page 5-21                            |
| Requirement: Modulation on U and V axis must be within 0.5°.                              |                                      |
| <input type="checkbox"/> 15. Check Spurious Output  | Page 5-23                            |
| Requirement: less than 32 mV.   |                                      |
| <input type="checkbox"/> 16. Adjust R313, L337 and L354                                   | Page 5-23                            |
| Requirement: Maximum amplitude with minimum modulation.                                   |                                      |

**Performance Check/Calibration—Type 141A/R141A**

- 17. Check/Adjust Spurious Subcarrier                      Page 5-25  
 Requirement: 4.43 MHz aberration between burst and first colour bar must be less than or equal to 32 mV peak to peak.
- 18. Check Chrominance Amplitudes                      Page 5-26  
 Requirements: See complete procedure.
- 19. Adjust Chrominance Amplitudes                      Page 5-29  
 Requirement: See complete procedure.
- 20. Check/Adjust Burst Amplitude                      Page 5-30  
 Requirement: V Component . . . . . 212 mV peak to peak within 3%.  
 Requirement: U Component . . . . . 212 mV peak to peak within 3%.  
 Requirement: Burst . . . . . 300 mV peak to peak within 3%.
- 21. Check/Adjust Setup Level                      Page 5-31  
 Requirement: Blanking level to black bar must be 175 mV within 1%.
- 22. Check/Adjust Colour Bar Luminance                      Page 5-32  
 Level Amplitudes  
 Requirement: See complete procedure.
- 23. Check/Adjust Peak White Risetime and                      Page 5-33  
 Aberrations  
 Requirement: Risetime, 100 ns within 10%; aberrations, less than or equal to 2%.
- 24. Check/Adjust Staircase Level Amplitudes                      Page 5-34  
 Requirement: 140 mV,  $\pm 1\%$  between steps, and 700 mV, within 1% from blanking level to fifth step.
- 25. Check/Adjust Staircase Modulation                      Page 5-36  
 Amplitude  
 Requirement: Modulation must be present on each staircase level; modulation must be 140 mV peak to peak within 3%.
- 26. Check Staircase Modulation Risetime                      Page 5-36  
 and Duration  
 Requirement: Risetime, 260 ns within 15%; Duration, 39  $\mu$ s within 5%.
- 27. Check/Adjust Staircase Level Risetime                      Page 5-37  
 and Aberrations  
 Requirement: Risetime, 260 ns within 15%; aberrations, equal to or less than 2%.
- 28. Check Line Sync Risetime                      Page 5-38  
 Requirement: Risetime must be between 230 ns and 290 ns.
- 29. Check Comp Sync Amplitude and                      Page 5-38  
 Outputs  
 Requirement: Amplitude, 4 volts peak to peak within 0.2 Volts.
- 30. Adjust Comp Sync Transient Response                      Page 5-39  
 and Risetime  
 Requirement: See complete procedure.
- 31. Check/Adjust Output Amplifiers                      Page 5-39  
 Requirement: See complete procedure.
- 32. Check/Adjust Horizontal Detail Timing                      Page 5-42  
 Requirement: See complete procedure.
- 33. Check/Adjust Luminance to Chrominance                      Page 5-44  
 Delay  
 Requirement: Delay, 20 ns or less.
- 34. Check Chrominance Risetime                      Page 5-44  
 Requirement: Risetime, 260 ns within 10%.
- 35. Check/Adjust 4.43 MHz Bandpass Filter                      Page 5-45  
 Requirement: See complete procedure.
- 36. Check/Adjust Chrominance Amplifier                      Page 5-47  
 Gain  
 Requirement: See complete procedure.
- 37. Check VITS and Bruch Sequence                      Page 5-49  
 Requirement: See complete procedure.
- 38. Check Other Signal Outputs                      Page 5-50  
 Requirement: 1.000 MHz . . . . . 1 volt peak to peak within 0.2 V.  
 25 Hz . . . . . 1 volt within 0.2 V.  
 (0 V for  $\approx 20$  ms and 1 V for  $\approx 20$  ms.)  
 12.5 Hz . . . . . 1 volt within 0.2 V.  
 (0 V for  $\approx 40$  ms and 1 V for  $\approx 40$  ms.)
- 39. Check Instrument Return Loss                      Page 5-50  
 Requirement: See complete procedure.
- 40. Check Diff Gain and Diff Phase                      Page 5-53  
 Requirement: Diff Gain, less than 0.5%; Diff Phase, less than 0.1°.
- 41. Check V Axis Phasing                      Page 5-54  
 Requirement: See complete procedure.

## PERFORMANCE CHECK/CALIBRATION PROCEDURE

### General

The following procedure is arranged in a sequence designed for checking or calibration with minimum interaction of adjustments and reconnection of equipment. However, some adjustments affect the calibration of other circuits within the instrument, and it may be necessary to check the operation of other parts of the instrument. When a step interacts with others, the steps which need to be checked are noted in the "INTERACTION . . . . . " step.

#### NOTE

If adjustments are made on the power supplies, the calibration of the entire instrument must be checked.

Do not preset internal controls unless the instrument has been repaired or is known to be seriously out of adjustment. If repairs have been made, preset internal controls to mid-range in the affected circuits.

Steps titled "CHECK . . . ." or "CHECK/ADJUST . . . ." are a combined Performance Check and Calibration procedure. When performing a Performance Check only, do not do the ADJUST portion of the step. For convenience, the actual portion of the steps where an adjustment(s) is made are printed in red. Steps titled "ADJUST . . . . ." are used only with a complete Calibration of the instrument.

#### NOTE

The Type R141A is calibrated in accord with PAL Signal specifications per CCIR as follows:

$$Y = .587G + .299R + .114B$$

$$V = .877 (R-Y)$$

$$U = .493 (B-Y)$$

The symbol **Ⓢ** is used to identify the steps in which an adjustment is made. To prevent recalibration of other circuits when performing a partial calibration, readjust only if the listed tolerance is not met. However, when performing a complete calibration, best overall performance will be provided if each adjustment is made to the exact setting.

In the following procedure, a test equipment setup picture is shown for each major group of adjustments and checks. Following each setup picture is a complete list of front-panel control settings for the Type R141A. To aid in locating individual controls which have been changed during the complete Performance Check and/or Calibration, these control names are printed in bold type. If only a Partial Performance Check and/or Calibration is performed, start with the preceding setup. (All test equipment and connections are disconnected.) Type R141A front-panel and rear-panel control titles and output connectors are capitalized (e.g., COMP SYNC). Internal adjustment titles are initial capitalized only (e.g., H Sync Start). Unless stated otherwise, all connections are made to the Type R141A front-panel connectors.

The following procedure uses the equipment and fixtures previously listed in this section of the manual. If equipment and fixtures are substituted, control settings or test equipment setup may need to be altered to meet the requirements of the equipment used.

#### NOTE

All waveforms shown in this procedure are actual photographs taken with a Tektronix Oscilloscope Camera System.

### Preliminary Procedure

1. (Calibration Procedure only.) Remove the Type R141A from any enclosure so as to provide access to all internal adjustments and test points, including rear-panel connectors. (Exception. See Steps 6, 21, and 39.)

2. (Calibration Procedure only.) Lay the Type R141A on its side for access to the Power Supply board.

3. Connect the autotransformer to a suitable power source and the Type R141A to the autotransformer output.

4. Set the autotransformer output voltage to the design center voltage for which the Type R141A LINE VOLTS selector switch has been set.

5. Set the Type R141A POWER switch to ON. Allow at least 20 minutes warmup at 25°C, ±5°C before checking and/or calibrating the instrument to the given accuracy.

6. Set the Type R141A and Test Equipment controls as described following Fig. 5-1.

### NOTES

---

---

---

---

---

---

---

---

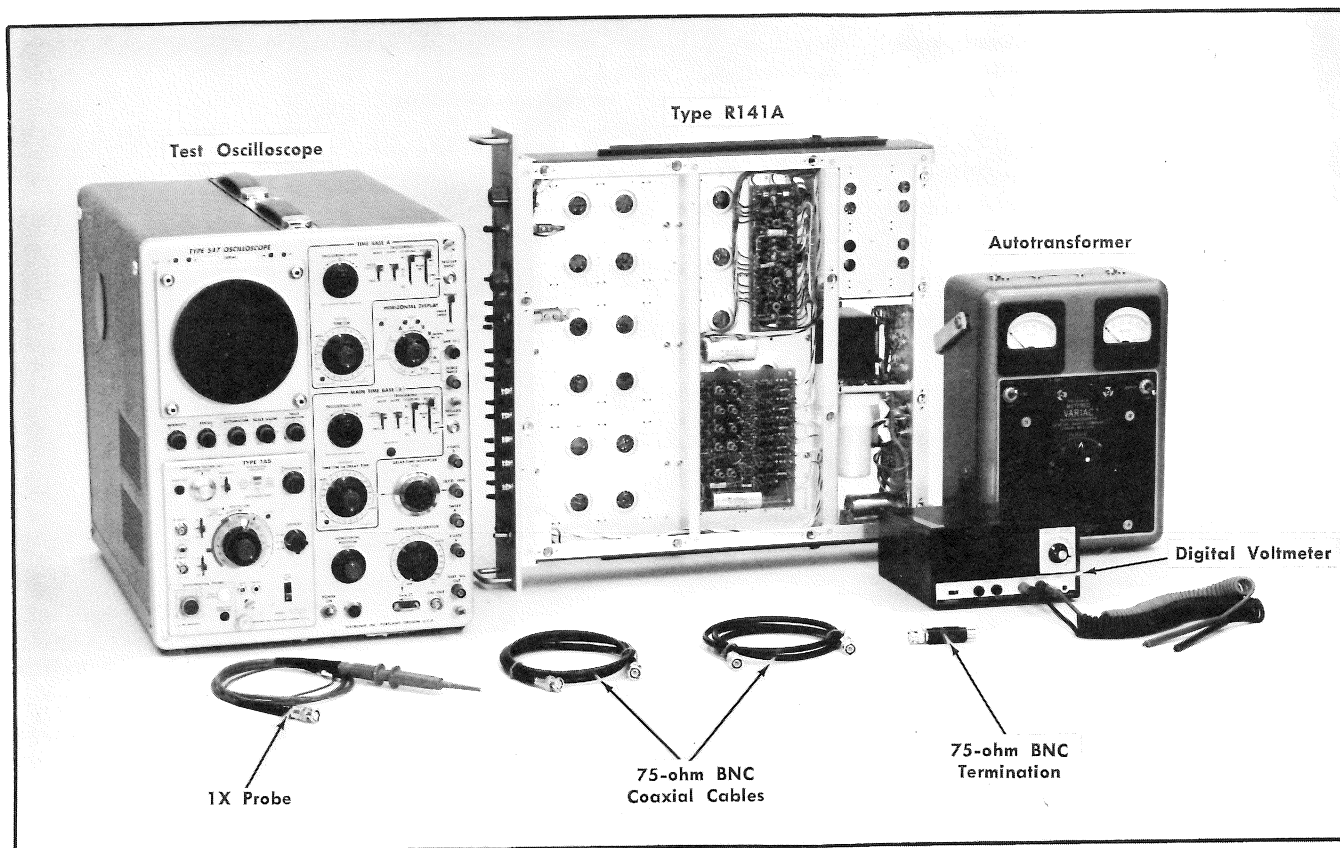

Fig. 5-1. Equipment required for steps 1 and 2.

**Type R141A Controls**

COLOUR BARS	
U	Up
V	Up
Y	Up
WHITE REF	Up
AMPLITUDE	75%, 0 SETUP
MODULATED STAIRCASE	
SUBCARRIER MOD	Up
STEPS	Down
BURST	
U	Up
V	Up
BRUCH SEQ	Up
V AXIS PHASING	90°/270°
25 Hz OFFSET	Up
SYNC	Up
POWER	On
FULL FIELD	
COLOUR BAR/MODU-	COLOUR BAR
LATED STAIRCASE	
AVERAGE PICTURE LEVEL	50

**VERTICAL INSERTION TEST SIGNAL**

FIELD	BOTH
LINE	11/324

**Test Oscilloscope Controls**

Viewing	
Intensity	As desired
Focus	As desired
Astigmatism	As desired
Scale Illum	As desired
Trace Separation	0
Time Base A	
Triggering Level	Near 0, pushed in
Triggering	
Mode	Trig
Slope	—
Coupling	DC
Source	Ext
Time/Cm	20 $\mu$ s
Variable (Time/Cm)	Calibrated
Time Base B	Not used

## Performance Check/Calibration—Type 141A/R141A

Horizontal Display	A
Sweep Magnifier	Off
Single Sweep	Normal
Delay-Time Multiplier	Not used
Horizontal Position	Midrange
Vernier (Horizontal Position)	Midrange
Power	On
Amplitude Calibrator	Off

### Type 1A5 Controls

A Input AC-GND-DC	GND
B Input AC-GND-DC	GND
Volts/Cm	.2 V
Variable (Volts/Cm)	Cal
Display	A-Vc
Position	Midrange
Step Atten Bal	As is
Comparison Voltage	
Amplitude	0-0
Polarity	0

### Digital Voltmeter Controls

Function/Range	Volts/150 V
On/Off	On

## 1. Adjust Regulated Power Supplies

- a. Test equipment is shown in Fig. 5-1.
- b. Connect the digital voltmeter leads between pins Y and X on the Type R141A Power Supply board (see Fig. 5-2).
- c. CHECK—Digital voltmeter readout;  $-15\text{ V}$ ,  $\pm 3\%$ .
- d. ADJUST—  $-15\text{ Volt Adj}$ , R886, (see Fig. 5-2) for  $-15\text{ volts}$ .
- e. Disconnect the digital voltmeter lead from pin Y and reconnect it to pin AG.
- f. Set the digital voltmeter Function/Range switch to Volts/15 V.
- g. CHECK—Digital voltmeter readout;  $+3.6\text{ V}$ ,  $\pm 3\%$ .
- h. ADJUST— $+3.6\text{ V Volt Adj}$ , R856 for  $+3.6\text{ volts}$ .
- i. Disconnect the digital voltmeter lead from pin AG and reconnect it to pin AF.
- j. CHECK—Digital voltmeter readout;  $+10\text{ V}$ ,  $\pm 3\%$ .
- k. ADJUST—  $+10\text{ Volt Adj}$ , R836 for  $+10\text{ volts}$ .
- l. Repeat parts b through k.
- m. Disconnect the digital voltmeter leads from pins AF and X.

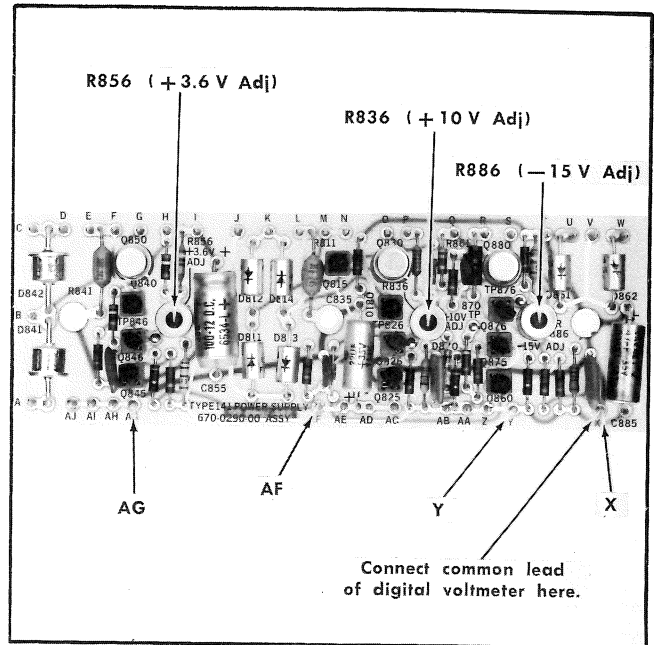

Fig. 5-2. Power supply board test point and adjustment locations.

## 2. Check Power Supply Regulation and Ripple

### NOTE

Tolerances for this step are not instrument specifications; rather, they are guides to determine whether complete instrument calibration is needed.

- a. From the Type R141A COMP VIDEO connector, connect a 75 ohm coaxial cable and a 75 ohm termination to the Type 1A5 A Input connector.
- b. From the Type R141A rear panel LINE DRIVE connector, connect a 75 ohm coaxial cable to the test oscilloscope Time Base A Trigger Input connector.
- c. Set the Type 1A5 A Input AC-GND-DC switch to DC.
- d. Set the test oscilloscope Time Base A Trigger Level control for a triggered display, and the test oscilloscope viewing controls for a sharply focused and well defined display.
- e. Rotate the test oscilloscope Horizontal Position control and the Type 1A5 Position control to center the display on the test oscilloscope.
- f. Set the Type 1A5 Volts/Cm switch to .1 V and the Variable (Volts/Cm) control for a display amplitude of 6 cm, as measured on the test oscilloscope, between peak white and the sync tip.
- g. CHECK—Test oscilloscope display; note stability and amplitude.
- h. Set the autotransformer output voltage to the lower voltage listed for the LINE VOLTS selector position being used.

**Performance Check/Calibration—Type 141A/R141A**

i. CHECK—Test oscilloscope display; amplitude and/or stability of the display must not have changed from that noted in part g.

j. Set the autotransformer output voltage to the higher voltage listed for the LINE VOLTS selector position being used.

k. Repeat part i, then return the autotransformer output voltage to the design center voltage listed for the LINE VOLTS selector position being used.

**NOTE**

For Performance Check, proceed to Part x.

l. Set the Type 1A5 A Input AC-GND-DC switch to GND, B Input AC-GND-DC switch to AC, Volts/Cm switch to 10 mV, Variable (Volts/Cm) switch to Cal, and the Display switch to Vc-B.

m. Set the test oscilloscope Time Base A Time/Cm switch to 5 ms and the Triggering Switches to Auto, +, AC, and Line.

n. From the Type 1A5 B Input connector, connect a 1X probe to pin Y (−15 V) on the Type R141A Power Supply board (see Fig. 5-2).

o. CHECK—Test oscilloscope display; amplitude must be  $\leq 50$  mV peak to peak.

p. Repeat parts (in listed order) h, o, j, and o.

q. Disconnect the 1X probe from pin Y and reconnect it to pin AF.

r. Repeat parts o and p.

s. Disconnect the 1X probe from pin AF and reconnect it to pin AG.

t. Set the autotransformer output voltage to the design center voltage being used.

u. Set the Type 1A5 Volts/Cm switch to 20 mV.

v. CHECK—Test oscilloscope display; amplitude must be  $\leq 100$  mV peak to peak.

w. Repeat parts (in listed order) h, v, j, and v.

x. Disconnect all test equipment and connections; connect the Type R141A directly to a suitable power source.

**NOTES**

---

---

---

---

---

---

---

---

---

---

---

---

---

---

---

---

---

---

---

---

---

---

---

Performance Check/Calibration—Type 141A/R141A

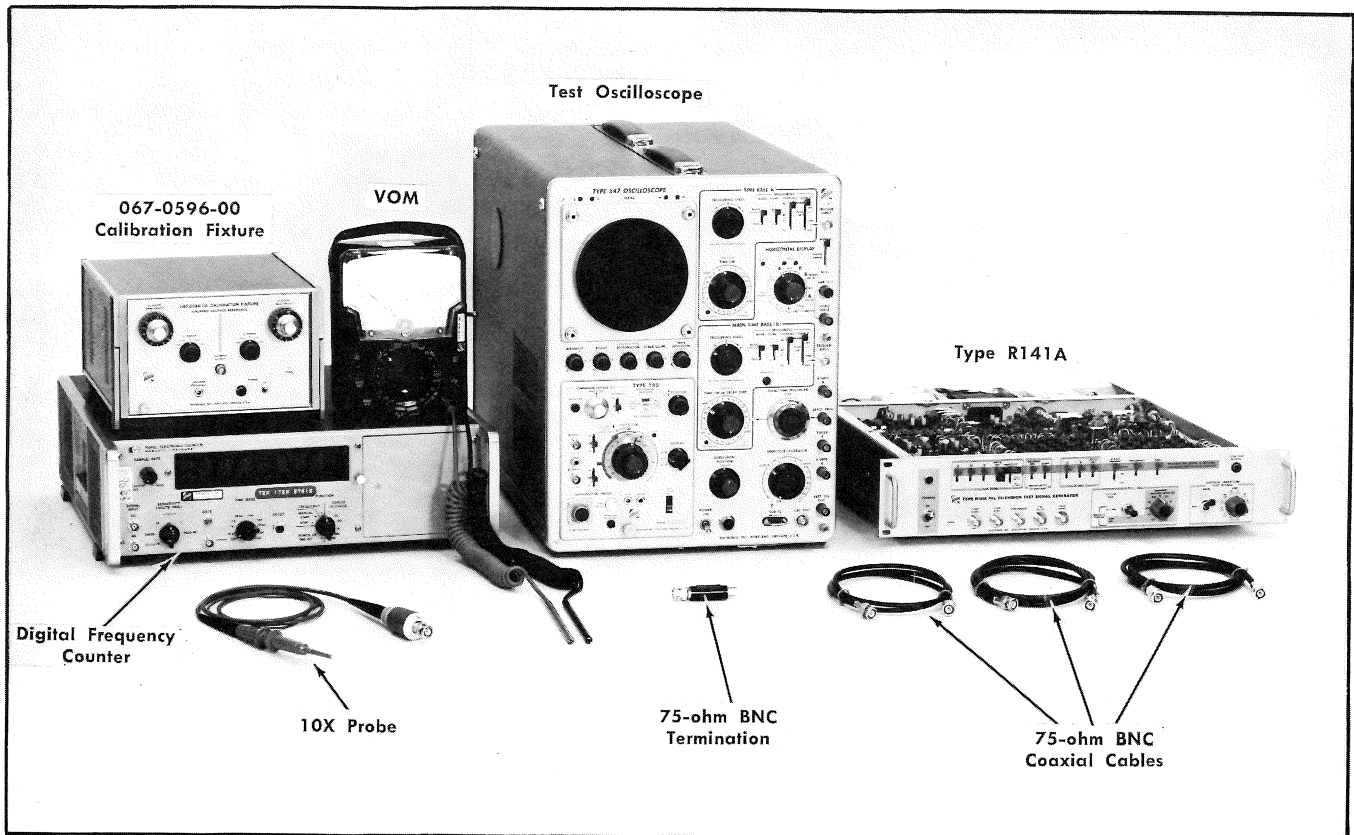

Fig. 5-3. Equipment required for steps 3 through 5.

**Type R141A Controls**

<b>COLOUR BARS</b>	
U	Up
V	Up
Y	Up
WHITE REF	Up
AMPLITUDE	75%, 0 SETUP
<b>MODULATED STAIRCASE</b>	
SUBCARRIER MOD	Up
<b>STEPS</b>	<b>Up</b>
<b>BURST</b>	
U	Up
V	Up
BRUCH SEQ	Up
V AXIS PHASING	90°/270°
25 Hz OFFSET	Up
SYNC	Up
POWER	On
<b>FULL FIELD</b>	
COLOUR BAR/MODU- LATED STAIRCASE	COLOUR BAR
AVERAGE PICTURE LEVEL	50

**VERTICAL INSERTION TEST SIGNAL**

FIELD	BOTH
LINE	11/324

**Test Oscilloscope Controls**

<b>Viewing</b>	
Intensity	As desired
Focus	As desired
Astigmatism	As desired
Scale Illum	As desired
Trace Separation	0
<b>Time Base A</b>	
Triggering Level	0, pushed in
<b>Triggering</b>	
<b>Mode</b>	<b>Trig</b>
<b>Slope</b>	—
Coupling	AC
<b>Source</b>	<b>Int (Norm)</b>
<b>Time/Cm</b>	.1 μs
Variable (Time/Cm)	Calibrated
Time Base B	Not used



Horizontal Display	A
Sweep Magnifier	Off
Single Sweep	Normal
Delay-Time Multiplier	As is
Horizontal Position	Midrange
Vernier (Horizontal Position)	Midrange
Power	On
Amplitude Calibrator	Off

**Type 1A5 Controls**

<b>A Input AC-GND-DC</b>	<b>DC</b>
<b>B Input AC-GND-DC</b>	<b>GND</b>
<b>Volts/Cm</b>	<b>.5 V</b>
Variable (Volts/Cm)	CAL
<b>Display</b>	<b>A-Vc</b>
Position	Midrange
Step Atten Bal	As is
Comparison Voltage	
Amplitude	0-0
Polarity	0

**067-0596-00 Calibration Fixture Controls**

$V_1$	
Range	0
Volts	0-0-0
$V_2$	
Range	0
Volts	0-0-0
Chopper Frequency	As is
Power	On

**Digital Frequency Counter Controls**

Set all controls such that a 4.43361875 MHz signal 2 volts peak to peak may be counted.

**NOTE**

To check or adjust the Type R141A Subcarrier Oscillator, an accurate 200 kHz frequency standard or frequency measuring device is required. In Europe, a standard frequency such as the Droitwich 200 kHz radio transmission may be used. Another method is direct frequency measurement with an Electronic Digital Frequency Counter. The two methods are described below.

**3A. Check/Adjust Subcarrier Oscillator Frequency** ①

- a. Test equipment is shown in Fig. 5-3.
- b. From the Type R141A SUBCARRIER connector, connect a 75 ohm coaxial cable and a 75 ohm termination to the Digital Frequency Counter Input connector.
- c. CHECK—Digital frequency counter readout; 4.43361875 MHz,  $\pm 5$  Hz.

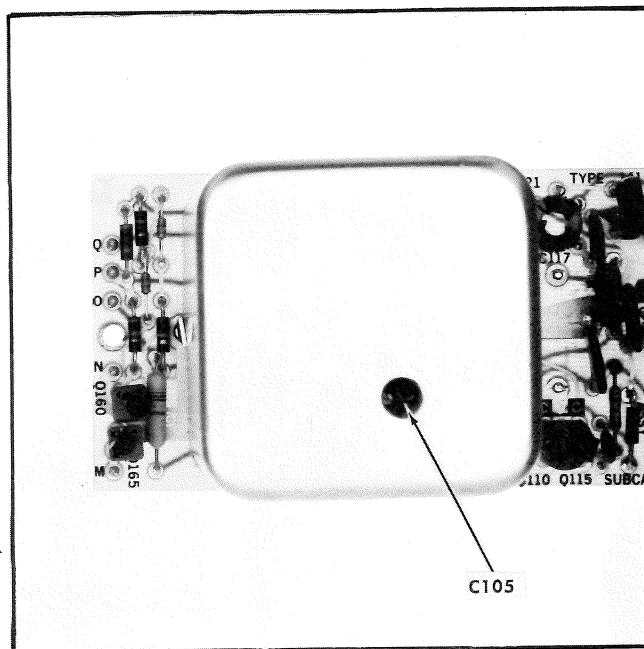

Fig. 5-4. Subcarrier Output board; oscillator adjustment location.

**NOTE**

Parts d through f apply only as a calibration procedure. Proceed to part g for performance check.

d. ADJUST—C105 (see Fig. 5-4) counterclockwise while observing the digital frequency counter readout; frequency must be adjustable to at least 4.43362375 MHz (5 Hz above center frequency).

e. ADJUST—C105 clockwise while observing the digital frequency counter readout; frequency must be adjustable to at least 4.43361375 MHz (5 Hz below center frequency).

f. ADJUST—C105 for 4.43361875 MHz as indicated on the digital frequency counter readout.

g. Disconnect the 75 ohm coaxial cable and the 75 ohm termination.

**3B. (Alternate Procedure) Check/Adjust Subcarrier Oscillator Frequency** ①

- a. Trigger the test oscilloscope externally from the standard frequency source.
- b. From the Type R141A rear-panel 1.000 MHz REF FREQ connector, connect a 75 ohm coaxial cable and a 75 ohm termination to the Type 1A5 A Input connector.
- c. Set the Type 1A5 controls and switches for a display amplitude of approximately 5 cm using DC coupling.
- d. Set the test oscilloscope Time/Cm switch to .1  $\mu$ s.
- e. CHECK—Test oscilloscope display; display must not drift left or right across the test oscilloscope graticule.

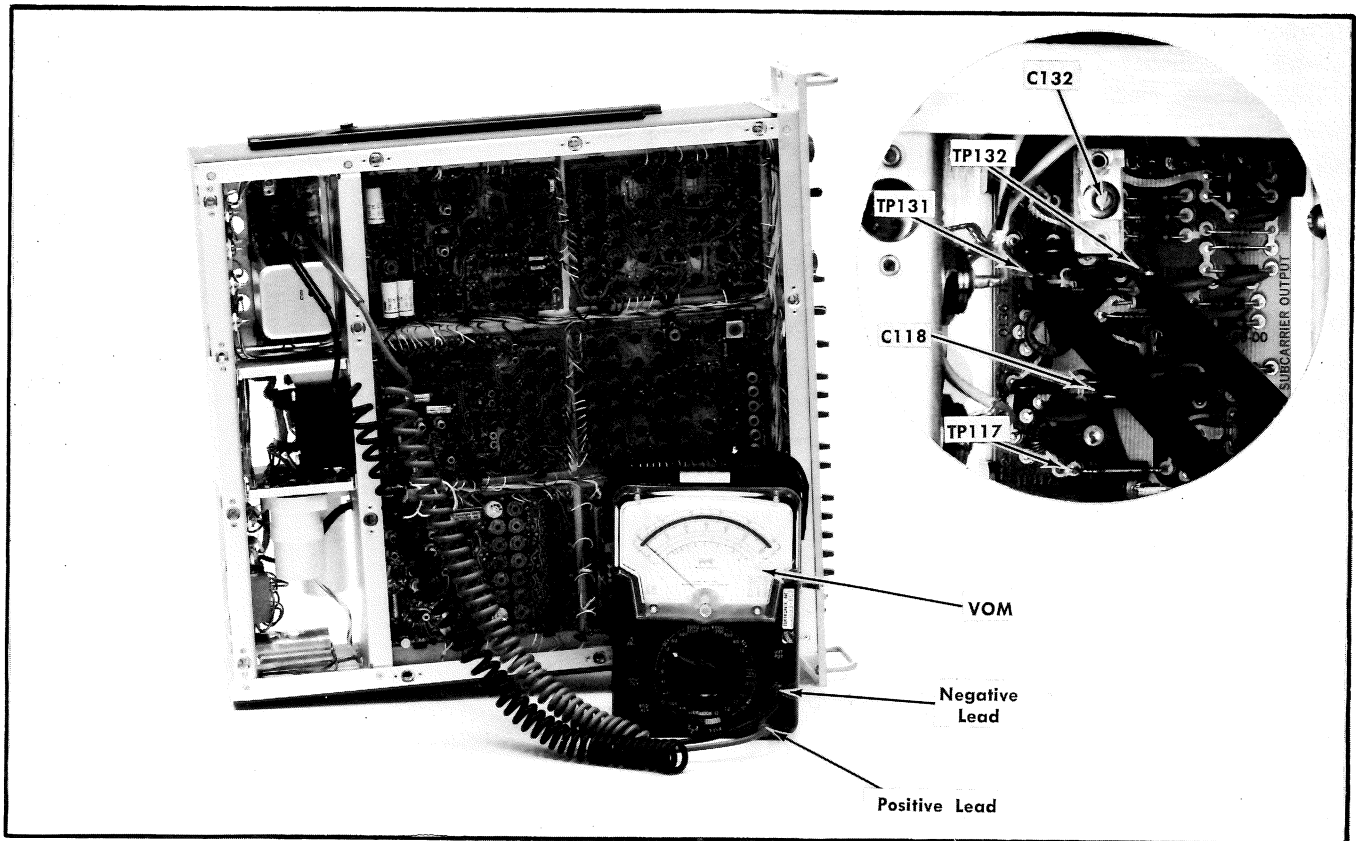

Fig. 5-5. Subcarrier Output board test point and adjustment locations.

f. ADJUST—C105 (see Fig. 5-4) for the least amount of drift.

**NOTE**

When the 1 MHz oscillator is exactly 1.00000 MHz (no drift) the subcarrier oscillator frequency will be 4.43361875 MHz.

g. Disconnect all test equipment and reset the Test Oscilloscope and Type 1A5 switches and controls as listed following Fig. 5-3.

**4. Check/Adjust Subcarrier Amplitude** **ⓘ**

a. Test equipment is shown in Fig. 5-3.

b. From the Type R141A SUBCARRIER connector, connect a 75 ohm coaxial cable and a 75 ohm termination to the Type 1A5 A Input connector.

c. Set the test oscilloscope Triggering Level control for a triggered display.

d. CHECK—Test oscilloscope display; amplitude of 4.43 MHz signal must be 2 volts peak to peak, within 0.2 V.

**NOTE**

Parts e through n apply only as a calibration procedure. Proceed to part o for performance check.

e. Disconnect the 75 ohm coaxial cable from the Type R141A SUBCARRIER connector.

f. Set the Type 1A5 A Input AC-GND-DC switch to GND, B Input AC-GND-DC switch to AC, Display switch to Vc-B, and the Volts/Cm switch to .2 V.

g. Connect a 10X probe from the Type 1A5 B Input connector to TP117 on the Subcarrier Output board (see Fig. 5-5).

h. CHECK—Test oscilloscope display; amplitude must be at least 5 volts peak to peak.

**NOTE**

If the peak to peak voltage of the display at TP117 is less than 5 volts, a new value of C118 (see Fig. 5-5) must be selected until the requirement of part h is obtained.

i. Remove the 10X probe from TP117 and the Type 1A5. Then, reset the Type 1A5 controls as listed following Fig. 5-3.

j. Connect the VOM between TP131 and TP132 on the Subcarrier Output board as shown in Fig. 5-5.

k. ADJUST—C132 (see Fig. 5-5) for minimum deflection on the VOM.

l. Disconnect the VOM from TP131 and TP132.

## Performance Check/Calibration—Type 141A/R141A

m. Reconnect the 75 ohm coaxial cable disconnected in part e to the Type R141A SUBCARRIER connector.

n. Set the Type 1A5 Volts/Cm switch to .5 V, Display Switch to A-Vc and the A Input AC-GND-DC switch to DC, then repeat parts c and d.

o. Disconnect the 75 ohm coaxial cable from the Type R141A SUBCARRIER connector and reconnect it to the Type R141A rear-panel upper COLOUR SUBCARRIER connector.

p. Repeat parts c and d.

q. Disconnect the 75 ohm coaxial cable from the Type R141A rear-panel upper COLOUR SUBCARRIER connector and reconnect it to the lower COLOUR SUBCARRIER connector.

r. Repeat parts c and d.

s. Test equipment remains connected.

### 5. Check Subcarrier Channel Isolation

a. From the 067-0596-00 calibration fixture Chopped Output connector, connect a 75 ohm coaxial cable to the Type 1A5 B Input connector.

b. Disconnect the 75 ohm coaxial cable from the Type R141A rear-panel lower COLOUR SUBCARRIER connector and reconnect it to the Type R141A SUBCARRIER connector.

c. Set the test oscilloscope Triggering Level control to 0, Triggering Mode switch to Auto Stability, Triggering Slope switch to +, and the Time/Cm switch to 50  $\mu$ s.

d. Set the Type 1A5 B Input AC-GND-DC switch to DC, and rotate the Position control to align the bottom of the display with the center graticule line on the test oscilloscope.

e. Set the Type 1A5 Display switch to A-B.

f. Set the 067-0596-00 calibration fixture  $V_2$  Volts control for a dial setting of approximately 2-5-0 and the  $V_2$  Range switch to +11 V.

#### NOTE

The test oscilloscope displays will be separated by approximately  $\frac{1}{2}$  cm.

g. Rotate the Type 1A5 Position control to center the distance between the two displays equal distance above and below the center graticule line on the test oscilloscope.

h. Rotate the 067-0596-00 calibration fixture  $V_2$  Volts control until the displays just coincide. (When the top of the bottom display just meets the bottom of the top display.)

i. Note and record the 067-0596-00 calibration fixture  $V_2$  Volts control dial setting.

j. Using a screwdriver, short the center conductors of the Type R141A rear-panel (upper and lower) COLOUR SUBCARRIER connectors to ground. (The short remains connected for parts k and l.)

k. Repeat part h.

l. Note and record the 067-0596-00 calibration fixture  $V_2$  Volts control dial setting.

m. Remove the short connected in part j.

n. Set the Type 1A5 A and B Input AC-GND-DC switches to GND, and the Volts/Cm switch to 1 V.

o. Disconnect the 75 ohm termination from the Type 1A5 A Input connector. Do not remove the 75 ohm coaxial cable from the Type R141A SUBCARRIER connector or the termination from the 75 ohm coaxial cable.

p. From the Type R141A rear-panel (upper or lower) COLOUR SUBCARRIER connector, connect a 75 ohm coaxial cable to the Type 1A5 A Input connector.

q. Set the Type 1A5 A Input AC-GND-DC switch to DC, and rotate the Position control to align the bottom of the display to the center graticule line on the test oscilloscope.

r. Set the 067-0596-00 calibration fixture  $V_2$  Volts control for a dial setting of approximately 4-7-5.

s. Set the Type 1A5 B Input AC-GND-DC switch to DC, Volts/Cm switch to .5 V. Then rotate the Position control to center the distance between the two displays equal distances above and below the center graticule line on the test oscilloscope.

t. Repeat part h.

u. Note and record the 067-0596-00 calibration fixture  $V_2$  Volts control dial setting.

v. Set the Type 1A5 A and B Input AC-GND-DC switches to GND and rotate the Position control to midrange.

w. Disconnect all test equipment and connections.

x. CHECK—Channel Isolation; ratio of voltage noted in part u to the difference of voltage noted in parts l and i must be at least 31.6 (30 dB).

$$\text{Channel isolation} = 20 \log \frac{V_u}{V_l - V_i}$$

### NOTES

**Performance Check/Calibration—Type 141A/R141A**

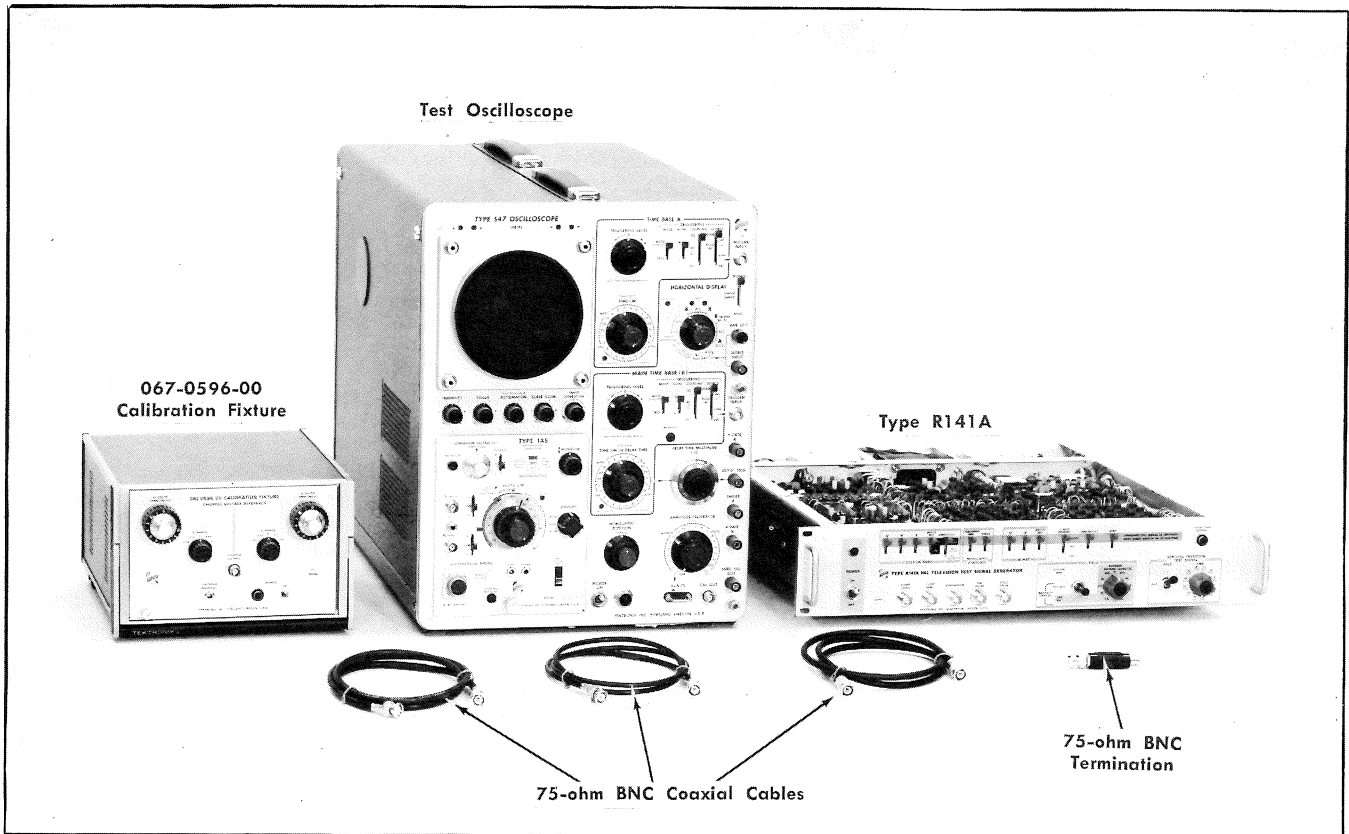

**Fig. 5-6. Test equipment required for steps 6 through 10.**

**Type R141A Controls**

COLOUR BARS	
U	Up
V	Up
Y	Up
WHITE REF	Up
AMPLITUDE	75%, 0 SETUP
MODULATED STAIRCASE	
<b>SUBCARRIER MOD</b>	<b>Down</b>
<b>STEPS</b>	<b>Down</b>
BURST	
U	Up
V	Up
BRUCH SEQ	Up
V AXIS PHASING	90°/270°
25 Hz OFFSET	Up
SYNC	Up
POWER	On
FULL FIELD	
<b>COLOUR BAR/MODU-</b>	<b>VAR APL</b>
<b>LATED STAIRCASE</b>	
<b>AVERAGE PICTURE</b>	<b>87.5</b>
<b>LEVEL</b>	

**VERTICAL INSERTION TEST SIGNAL**

FIELD	BOTH
LINE	11/324

**Test Oscilloscope Controls**

Viewing	
Intensity	As desired
Focus	As desired
Astigmatism	As desired
Scale Illum	As desired
Trace Separation	0
Time Base A	
Triggering Level	0, pushed in
Triggering	
<b>Mode</b>	<b>Trig</b>
<b>Slope</b>	<b>—</b>
<b>Coupling</b>	<b>DC</b>
<b>Source</b>	<b>Ext</b>
<b>Time/Cm</b>	<b>10 μs</b>
Variable (Time/Cm)	Calibrated
Time Base B	Not used

Horizontal Display	A
Sweep Magnifier	Off
Single Sweep	Normal
Delay-Time Multiplier	As is
Horizontal Position	Midrange
Vernier (Horizontal Position)	Midrange
Power	On
Amplitude Calibrator	Off

**Type 1A5 Controls**

<b>A Input AC-GND-DC</b>	<b>DC</b>
B Input AC-GND-DC	GND
<b>Volts/Cm</b>	<b>.2 V</b>
Variable. (Volts/Cm)	Cal
<b>Display</b>	<b>A-Vc</b>
Position	Midrange
Step Atten Bal	As is
Comparison Voltage	
Amplitude	0-0
Polarity	0

**067-0596-00 Calibration Fixture Controls**

V <sub>1</sub>	
Range	0
Volts	0-0-0
V <sub>2</sub>	
<b>Range</b>	<b>+ 1.1 V</b>
<b>Volts</b>	<b>2-0-0</b>
Chopper Frequency	As is
Power	On

**6. Check/Adjust Luminance Amplifier Gain** ①

- a. Test equipment is shown in Fig. 5-6.
- b. From the Type R141A COMP VIDEO connector, connect a 75 ohm coaxial cable and a 75 ohm termination to the Type 1A5 A Input connector.
- c. From the Type R141A rear-panel LINE DRIVE connector, connect a 75 ohm coaxial cable to the test oscilloscope Time Base A Trigger Input connector.
- d. Set the Type 1A5 Comparison Voltage Polarity switch to + and rotate the Comparison Voltage Amplitude control to position the 87.5% APL line of the display to the center graticule line on the test oscilloscope.
- e. Set the Type 1A5 Volts/Cm switch to 10 mV, then rotate the Comparison Voltage Amplitude control to reposition the 87.5% APL line to the center graticule line of the test oscilloscope.
- f. CHECK—Test oscilloscope display; modulation on the 87.5% APL line must be 30 mV peak to peak, ±20%.

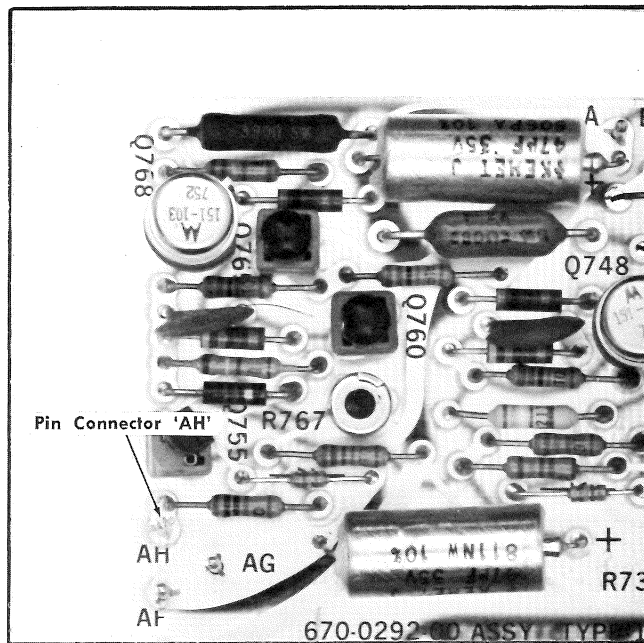

Fig. 5-7. Partial Bar Drive and Video Output board showing pin connector AH.

**NOTE**

Throughout the Performance Check/Calibration procedure, if only a Performance Check is being performed, the Type R141A top and bottom covers should not be removed. To accurately check or adjust the Luminance Amplifier Gain and VAR APL, access to the Type R141A Bar Drive and Video Output board is necessary. Remove the top cover, perform steps 6 through 10 and then replace the cover.

- g. Set the Type R141A POWER switch to OFF.
- h. Disconnect pin connector AH on the Bar Drive and Video Output board (see Fig. 5-7).

**CAUTION**

Place the disconnected lead so that no contact will occur between the metal pin connector and the chassis.

- i. Set the Type R141A POWER switch to ON.
- j. Set the Type 1A5 Volts/Cm switch to .2V, Comparison Voltage Polarity switch to 0, and rotate the Position control to center the display on the test oscilloscope.
- k. From the 067-0596-00 calibration fixture Chopped Output connector, connect a 75 ohm coaxial cable to the Type 1A5 B Input connector.
- l. Set the Type 1A5 B Input AC-GND-DC switch to DC, and the Display switch to A-B.
- m. Rotate the test oscilloscope Time Base A Triggering Level control for a triggered display.

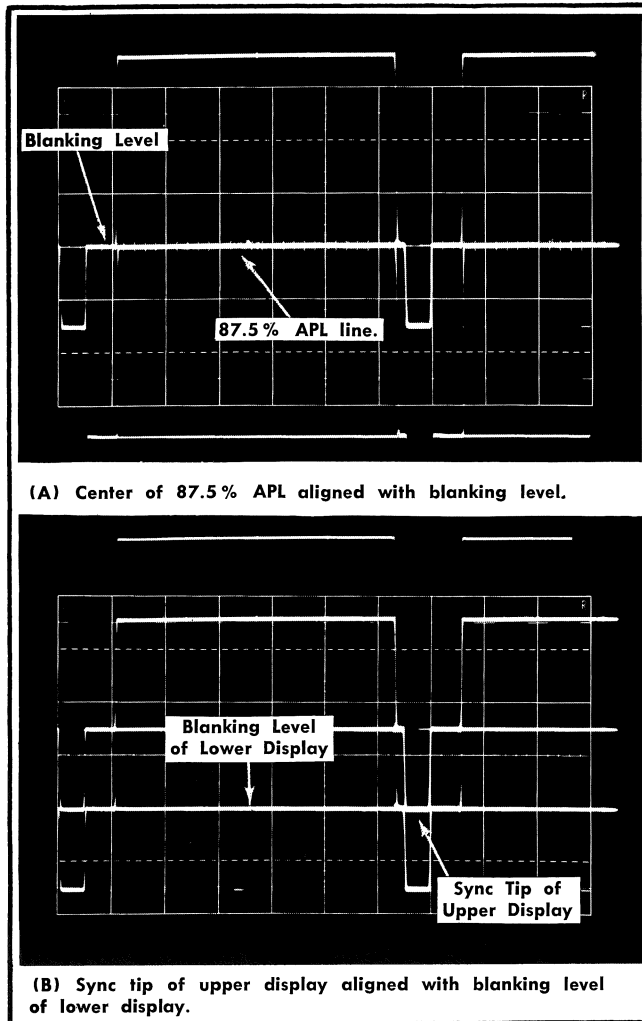

Fig. 5-8. Luminance and Sync Amplifiers properly adjusted.

**NOTE**

The test oscilloscope displays will be separated by approximately 1 major division.

- n. Rotate the 067-0596-00 calibration fixture  $V_2$  Volts control to 0-0-0 and note that the displays are superimposed.
- o. Set the 067-0596-00 calibration fixture  $V_2$  Volts control for a dial setting of 7-0-28 (700 mV).

**NOTE**

For the remainder of the Performance Check/Calibration procedure, all dial settings of the 067-0596-00 calibration fixture Volts dial(s) will include an error factor. See the 067-0596-00 calibration fixture operation manual for details.

- p. Observing the test oscilloscope display, rotate the 067-0596-00 calibration fixture  $V_2$  Volts control until the center of the 87.5% PL line aligns with the blanking level as shown in Fig. 5-8A.

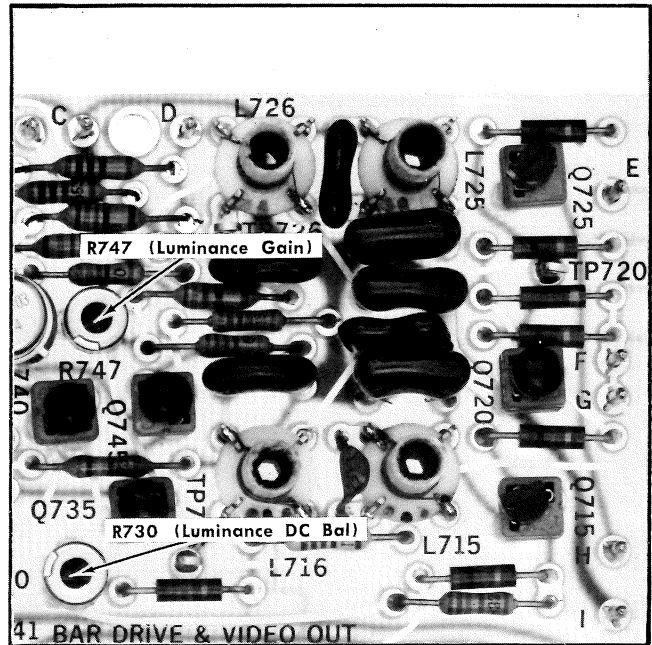

Fig. 5-9. Bar Drive and Video Output board adjustment locations.

- q. Set the Type 1A5 Volts/Cm switch to 10 mV; repeat part p.
- r. CHECK—067-0596-00 calibration fixture  $V_2$  Volts control dial setting; dial setting must be between 6-9-58 and 7-1-00 (700 mV,  $\pm 1\%$ ).
- s. Rotate the 067-0596-00 calibration fixture  $V_2$  Volts control for a dial setting of 7-0-28.
- t. ADJUST—Luminance Gain control, R747, (see Fig. 5-9) until the center of the 87.5% APL line aligns with the blanking level.
- u. Test equipment remains connected.

**7. Check/Adjust Sync Amplitude**

- a. Set the Type 1A5 Volts/Cm switch to .2 V.
- b. Set the 067-0596-00 calibration fixture  $V_2$  Range switch to  $-1.1$  V and rotate the  $V_2$  Volts control for a dial setting of 3-0-10 ( $-300$  mV).
- c. Observing the test oscilloscope display, rotate the 067-0596-00 calibration fixture  $V_2$  Volts control until the sync tip of the upper display just aligns with the blanking level of the lower display (see Fig. 5-8B).
- d. Set the Type 1A5 Volts/Cm switch to 10 mV; repeat part c.
- e. CHECK—067-0596-00 calibration fixture  $V_2$  Volts control dial setting; dial setting must be between 2-9-80 and 3-0-40 ( $-300$  mV,  $\pm 1\%$ ).
- f. Set the 067-0596-00 calibration fixture  $V_2$  Volts control for a dial setting of 3-0-10.

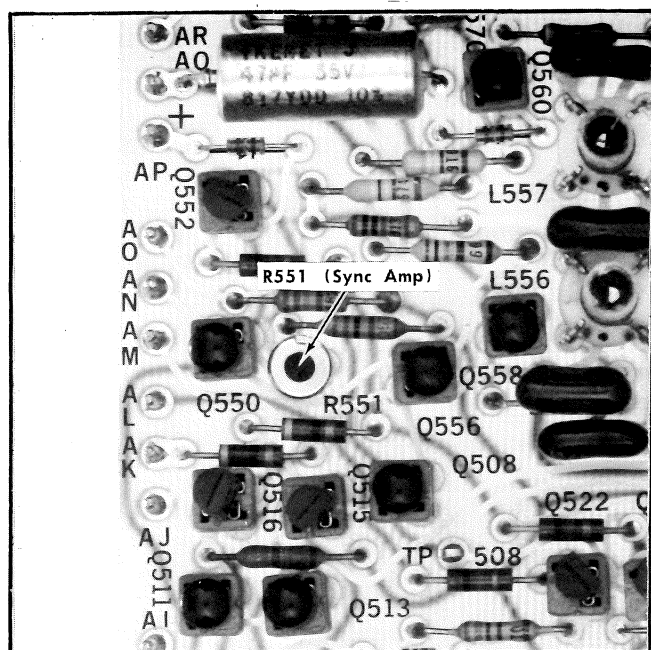

Fig. 5-10. Staircase board adjustment location.

g. ADJUST—Sync Amplifier control, R551, (see Fig. 5-10) until the sync tip of the upper display just aligns with the blanking level of the lower display.

h. Test equipment remains connected.

## 8. Check/Adjust Luminance Amplifier DC Balance

a. Set the Type 1A5 A and B Input AC-GND-DC switches to GND and the Volts/Cm switch to .2 V.

b. Rotate the Type 1A5 Position control to position the trace to the center graticule line on the test oscilloscope.

c. Set the Type 1A5 A Input AC-GND-DC switch to DC.

d. CHECK—Test Oscilloscope display; blanking level of the display must be within 0.1 volt of the reference established in part b of this step.

e. ADJUST—Luminance DC Bal control, R730, (see Fig. 5-9) until the blanking level of the display exactly coincides with the reference established in part b of this step.

f. INTERACTION—Repeat steps 6, 7, and 8a through 8e.

g. Test equipment remains connected.

## 9. Check Variable APL Amplitude

a. Set the Type R141A FULL FIELD APL Switch to 12.5.

b. Set the 067-0596-00 calibration fixture  $V_2$  Volts controls to 0-0-0.

c. Set the Type 1A5 B Input AC-GND-DC switch to DC, Volt/Cm switch to 10 mV, and rotate the Position control to position the blanking level of the display to the center graticule line on the test oscilloscope.

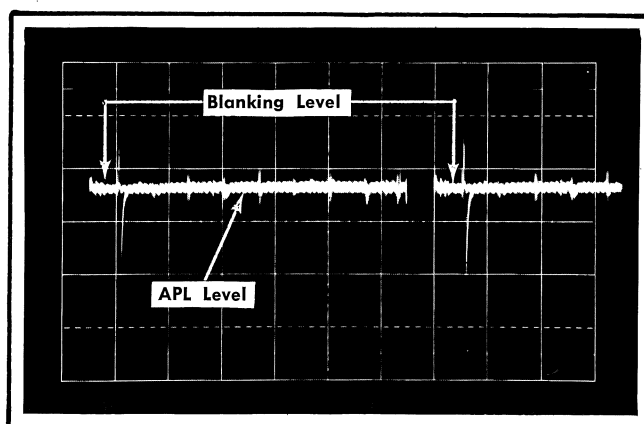

Fig. 5-11. Typical display with APL line superimposed on the blanking level to check APL amplitudes.

d. Set the 067-0596-00 calibration fixture  $V_2$  Volts control to approximately 0-7-0 and check that the  $V_1$  Range switch is set to 0.

e. Set the Type R141A FULL FIELD APL switch to 20.

f. Set the Type 1A5 Position control fully counterclockwise.

g. Observing the test oscilloscope display, rotate the 067-0596-00 calibration fixture  $V_2$  Volts control until the blanking level is superimposed on the 20% APL line as shown in Fig. 5-11.

h. CHECK—067-0596-00 calibration fixture  $V_2$  Volts control dial setting; dial setting must be between 0-6-87 and 0-7-16 (70 mV,  $\pm 2\%$ ).

i. Set the 067-0596-00 calibration fixture  $V_2$  Range switch to 0,  $V_1$  Range switch to +1.1 V and  $V_1$  Volts control to approximately 0-7-0.

j. Set the Type 1A5 Position control to approximately midrange.

k. Observing the test oscilloscope display, rotate the 067-0596-00 calibration fixture  $V_1$  Volts control until the APL line (as indicated by the APL switch setting) is superimposed on the blanking level as shown in Fig. 5-11.

l. Set the Type R141A FULL FIELD APL switch to 27.5.

m. Rotate the Type 1A5 Position control fully counterclockwise.

n. Set the 067-0596-00 calibration fixture  $V_2$  Range switch to -1.1 V.

o. Observing the test oscilloscope display, rotate the 067-0596-00 calibration fixture  $V_2$  Volts control until the blanking level is superimposed on the APL line.

p. CHECK—067-0596-00 calibration fixture  $V_2$  Volts control dial setting; dial setting must be between 0-6-87 and 0-7-16 (70 mV,  $\pm 2\%$ ).

q. Set the 067-0596-00 calibration fixture  $V_2$  Range switch to 0 and the  $V_1$  Volts control to approximately 1-4-0.

TABLE 5-1

Set APL switch to:	Type 1A5 Position control:	067-0596-00 Calibration Fixture			Repeat part:
		V <sub>1</sub> Range	V <sub>2</sub> Range	V <sub>1</sub> Volts	
NC <sup>2</sup>	Midrange	+1.1 V	0	≈2-1.0	k
42.5	CCW	NC	-1.1 V	NC	o and p
NC	Midrange	NC	0	≈2-8.0	k
50	CCW	NC	-1.1 V	NC	o and p
NC	Midrange	NC	0	≈3-5.0	k
57.5	CCW	NC	-1.1 V	NC	o and p
NC	Midrange	NC	0	≈4-2.0	k
65	CCW	NC	-1.1 V	NC	o and p
NC	Midrange	NC	0	≈4-9.0	k
72.5	CCW	NC	-1.1 V	NC	o and p
NC	Midrange	NC	0	≈5-6.0	k
80	CCW	NC	-1.1 V	NC	o and p
NC	Midrange	NC	0	≈6-3.0	k
87.5	CCW	NC	-1.1 V	NC	o and p

<sup>2</sup>NC - No change from previous setting.

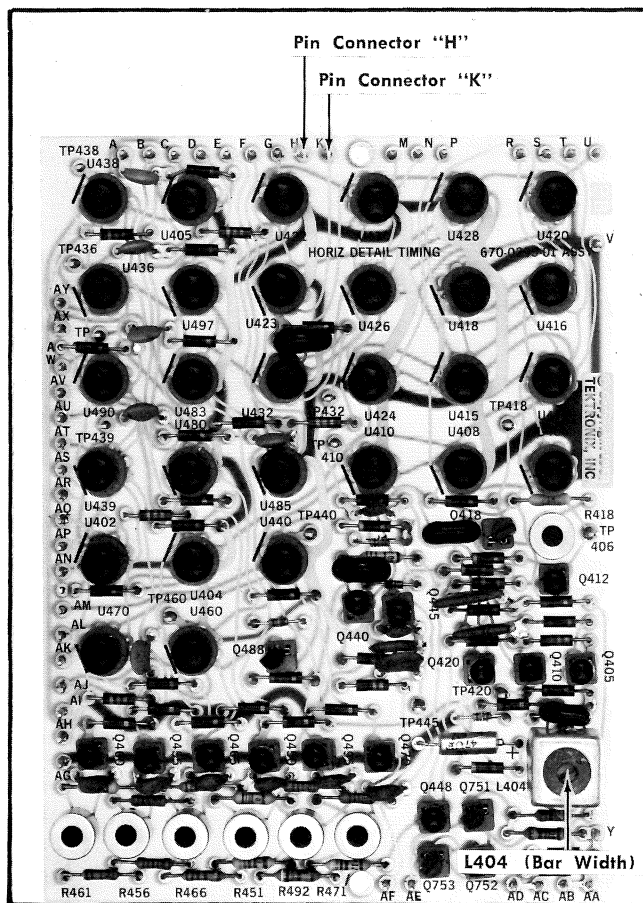

Fig. 5-12. Horiz Detail Timing board adjustment and pin connector locations.

r. Rotate the Type 1A5 Position control to approximately midrange.

s. Repeat part k.

t. Set the Type R141A FULL FIELD APL switch to 35.

u. Repeat parts m, n, o, and p.

v. Using the procedure just described for checking the 12.5, 20, and 27.5% APL switch settings, Fig. 5-11, check all remaining settings of the Type R141A FULL FIELD APL switch listed in Table 5-1.

**NOTE**

Steps 6, 7, 8, and 9 must be repeated if any of the above checks are not within listed tolerance.

w. Set the Type 1A5 Volts/Cm switch to .2 V, Display switch to A-Vc, and rotate the Position control to center the display on the test oscilloscope.

x. Test equipment remains connected.

y. Set the Type R141A POWER switch off.

z. Reconnect pin connector "AH" disconnected in step 6 part f.

**10. Check/Adjust Chroma Bar Width**

a. Disconnect pin connector "K" on the Type R141A Horiz timing board and reconnect it to pin "H" (see Fig. 5-12).

b. Set the Type R141A COLOUR BAR AMPLITUDE switch to 75%-25% SETUP, FULL FIELD COLOUR BAR/MODULATED STAIRCASE switch to COLOUR BAR and the POWER switch ON.





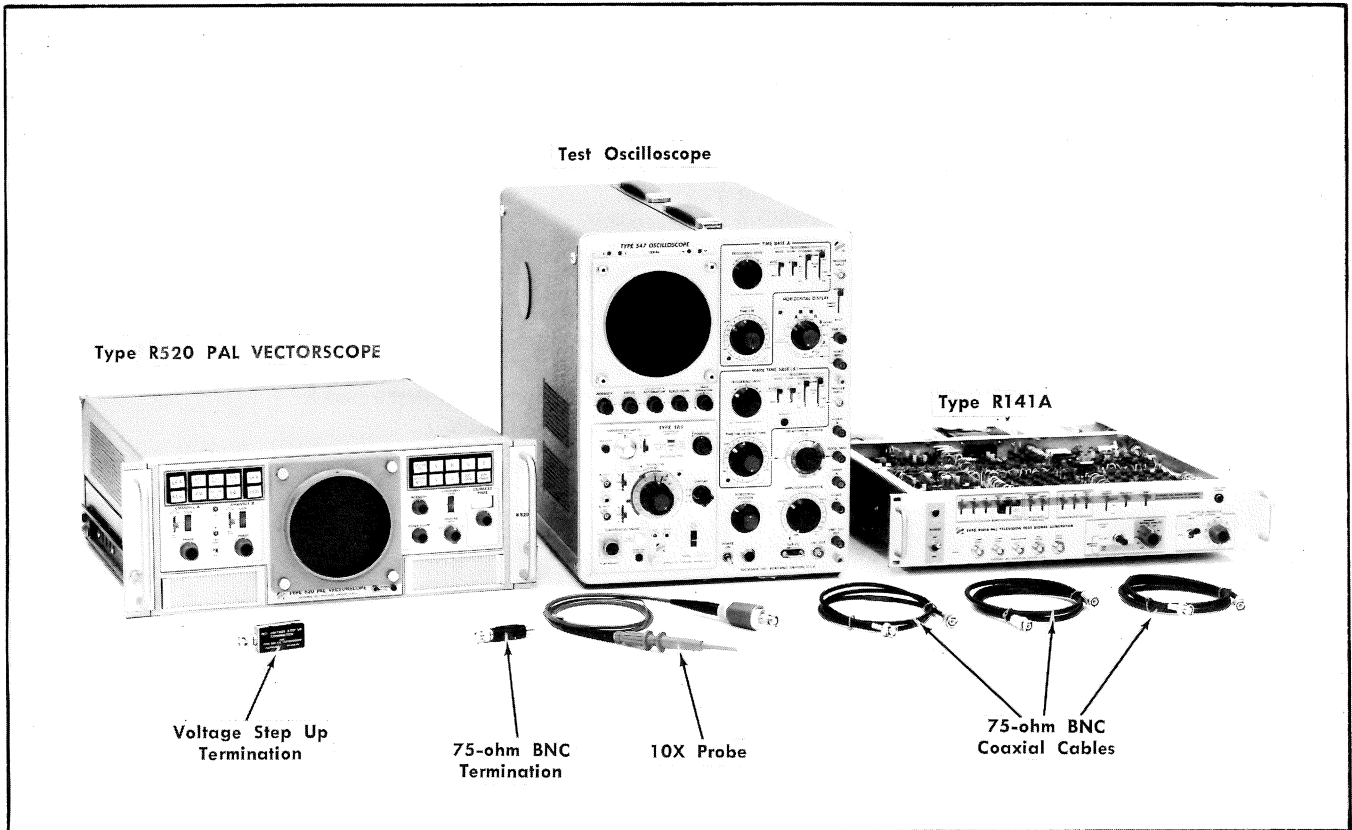

Fig. 5-14. Test equipment required for steps 11 through 16.

**Type R141A Controls**

COLOUR BARS	
U	Up
V	Up
Y	Up
WHITE REF	Up
<b>AMPLITUDE</b>	<b>75%, 0% SETUP</b>
MODULATED STAIRCASE	
<b>SUBCARRIER MOD</b>	<b>Up</b>
<b>STEPS</b>	<b>Up</b>
BURST	
U	Up
V	Up
BRUCH SEQ	Up
V AXIS PHASING	90°/270°
25 Hz OFFSET	Up
SYNC	Up
<b>POWER</b>	<b>On</b>
FULL FIELD	
COLOUR BAR/MODU- LATED STAIRCASE	COLOUR BAR

**AVERAGE PICTURE LEVEL 12.5**

VERTICAL INSERTION TEST SIGNAL	
FIELD	BOTH
LINE	11/324

**Test Oscilloscope Controls**

Viewing	
Intensity	As desired
Focus	As desired
Astigmatism	As desired
Scale Illum	As desired
Trace Separation	0
Time Base A	
Triggering Level	0, pushed in
Triggering	
Mode	Trig
Slope	—
Coupling	DC
Source	Ext
Time/Cm	10 μs
Variable (Time/Cm)	Calibrated

Time Base B	Not used
Horizontal Display	A
<b>Sweep Magnifier</b>	<b>Off</b>
Single Sweep	Normal
Delay-Time Multiplier	As is
Horizontal position	Midrange
Vernier (Horizontal Position)	Midrange
Power	On
Amplitude Calibrator	Off

**Type 1A5 Controls**

<b>A Input AC-GND-DC</b>	<b>AC</b>
<b>B Input AC-GND-DC</b>	<b>GND</b>
<b>Volts/Cm</b>	<b>5 mV</b>
Variable (Volts/Cm)	Cal
Display	A-Vc
Position	Midrange
Step Atten Bal	As is
Comparison Voltage	
Amplitude	0-0
Polarity	0

**Type R520 PAL Vectorscope Controls**

Signal Selector	CH A, A $\phi$ , Full Field
Channel A	
100%-75%-Max Gain	75%
Gain	Cal
Phase	As is
A Cal	As is
B Cal	As is
$\phi$ Ref	Burst
Channel B	Not used
Function Selector	Vector PAL
Intensity	As desired
Luminance Gain	Cal
Scale Illum	As desired
Display	Both
Calibrated Phase	0
Power	On
Quad Phase	As is
Gain Bal	As is
Horiz Position Clamp	As is
Beam Rotate	As is
Vert Position Clamp	As is
Focus	As desired
Field	1
Vert Position	As is
Burst Flag	As is
Sync	Int
Horiz Position	As is

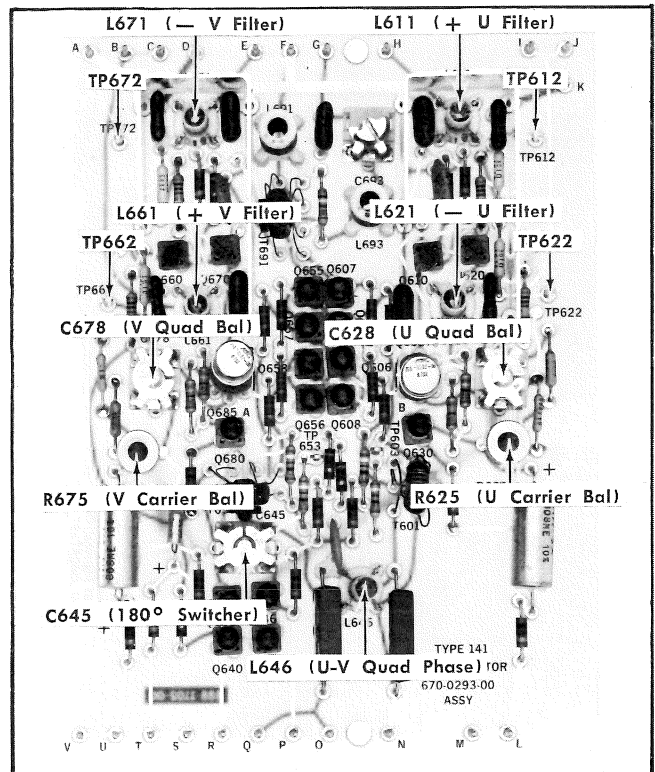

Fig. 5-15. U and V Modulator board adjustment and test point locations.

**11. Adjust U and V Modulator Filters**

- a. Test equipment is shown in Fig. 5-14.
- b. Connect a proper compensated 10 $\times$  probe to the Type 1A5 A Input connector.
- c. From the Type R141A rear-panel LINE DRIVE connector, connect a 75 ohm coaxial cable to the test oscilloscope Time Base A Trigger Input connector.
- d. Connect the 10 $\times$  probe tip to TP612 on the Type R141A U and V Modulator board; see Fig. 5-15.
- e. Set the test oscilloscope Time Base A Triggering Level control for a triggered display.
- f. ADJUST— +U Filter, L611, (see Fig. 5-15) for optimum square corner on the leading edges of the display as shown in Fig. 5-16A.
- g. Disconnect the 10 $\times$  probe from TP612 and reconnect it to TP622.
- h. ADJUST— -U Filter, L621, for optimum square corner on the leading edges of the display as shown in Fig. 5-16B.
- i. Disconnect the 10 $\times$  probe from TP622 and reconnect it to TP662.
- j. Set the Type 1A5 Volts/Cm switch to 10 mV.

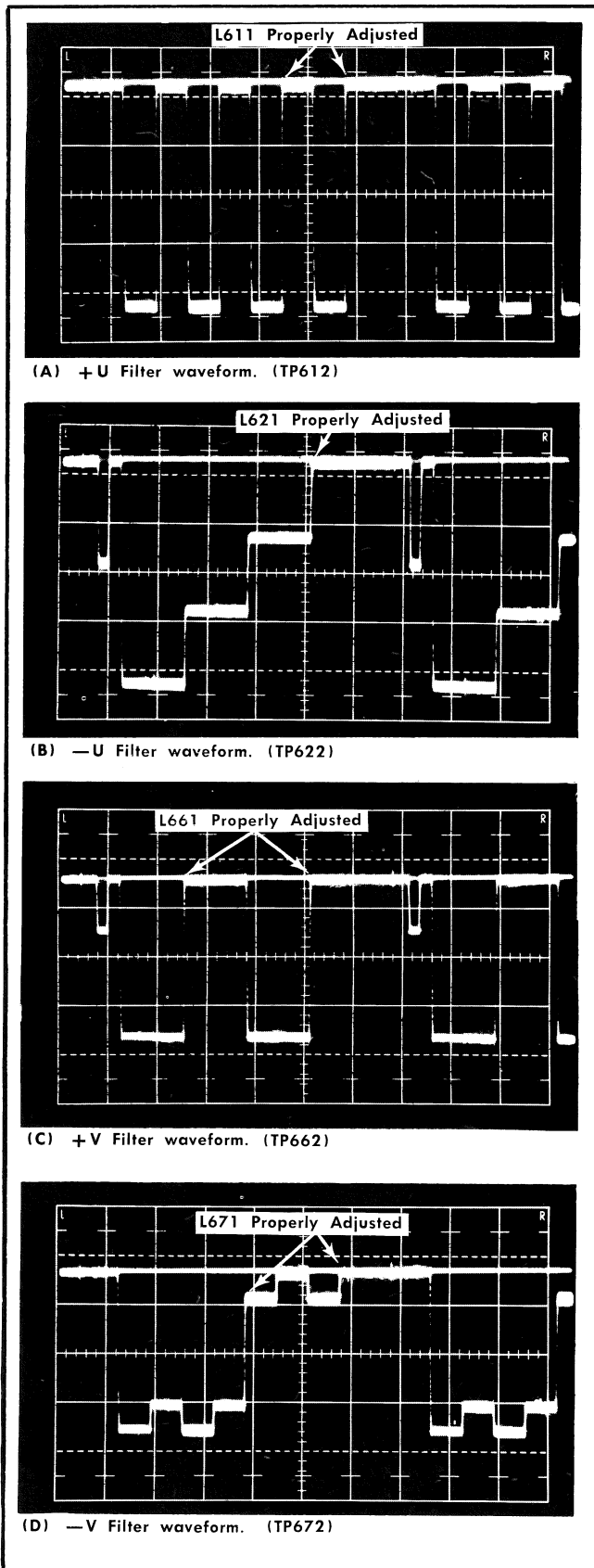

Fig. 5-16. Typical +U, -U, +V, and -V Filter waveforms.

k. ADJUST— +V Filter, L661, for optimum square corner on the leading edges of the display as shown in Fig. 5-16C.

l. Disconnect the 10X probe from TP662 and recont it to TP672.

m. ADJUST— -V Filter, L671, for optimum square corner on the leading edges of the display as shown in Fig. 5-16D.

n. Disconnect the 10X probe from TP672 and the Type 1A5 A Input connector.

o. Test equipment remains connected.

## 12. Check/Adjust U and V Quad Phase and Carrier Balance

a. Set the Type 1A5 Volts/Cm switch to .2V and the A Input AC-GND-DC switch to DC.

b. From the Type R141A COMP VIDEO connector, connect a 75 ohm coaxial cable and a 75 ohm termination to the Type 1A5 A Input connector.

c. Set the test oscilloscope Variable (Time/Cm) control for a display as shown in Fig. 5-17A.

d. Set the Type 1A5 Volts/Cm switch to 2mV and rotate the Position control to position the blanking level of the display to the center graticule line on the test oscilloscope.

e. CHECK—Test oscilloscope display; amplitude of chrominance on the blanking level must be less than or equal to 2.5 mV peak to peak, and equal on every line (see Fig. 5-17B).

f. ADJUST—V Quad Bal control, C678; U Quad Bal control C628; V Carrier Bal control, R675; U Carrier Bal control, R625, (see Fig. 5-15) for a chrominance amplitude on the blanking level of 2.5 mV peak to peak or less, and equal amplitude on each line.

### NOTE

C678, C628, R675, and R625 adjustments interact. Repeat the adjustments several times to obtain an absolute minimum.

g. Disconnect the 75 ohm termination from the Type 1A5 A Input connector and the 75 ohm coaxial cable from the 75 ohm termination.

h. Test equipment remains connected.

## 13. Check/Adjust U-V Quad Phase

a. From the Type 1A5 A Input connector, connect the 011-0109-00 Voltage Step Up Termination and the 75 ohm coaxial cable disconnected in Step 12g.

b. Set the Type 1A5 Volts/Cm switch to 50 mV, Comparison Voltage Polarity switch to +, and rotate the Comparison Voltage Amplitude control to position the center portion of the display to the center graticule line on the test oscilloscope.

c. Set the test oscilloscope Time Base A Variable (Time/Cm) control for a display as shown in Fig. 5-18A.

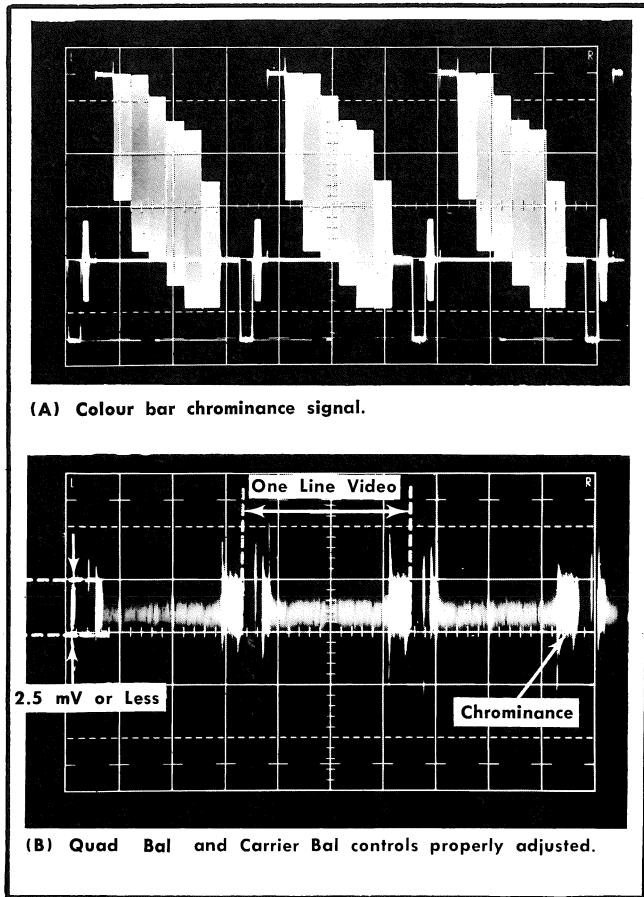

Fig. 5-17. Typical displays to check or adjust Quad phase and Carrier Balance.

d. Rotate the Type 1A5 Comparison Voltage Amplitude control to position the positive peaks of the display as shown in Fig. 5-18B.

e. CHECK—Test oscilloscope display; top portions of each individual colour bar must overlay. (See Fig. 5-18C for improper colour bar overlay.)

f. ADJUST—U-V Quad Phase control, L646, (see Fig. 5-15) until the colour bars overlay.

**NOTE**

It may be necessary to rotate the test oscilloscope Time Base A Variable (Time/Cm) control to display more than two complete lines of video until the display intensity suddenly brightens in order to see the effect of adjusting L646.

g. Set the Type 1A5 Comparison Voltage Polarity switch to —.

h. Repeat parts e and f, using the negative peaks of the display.

i. Test equipment remains connected.

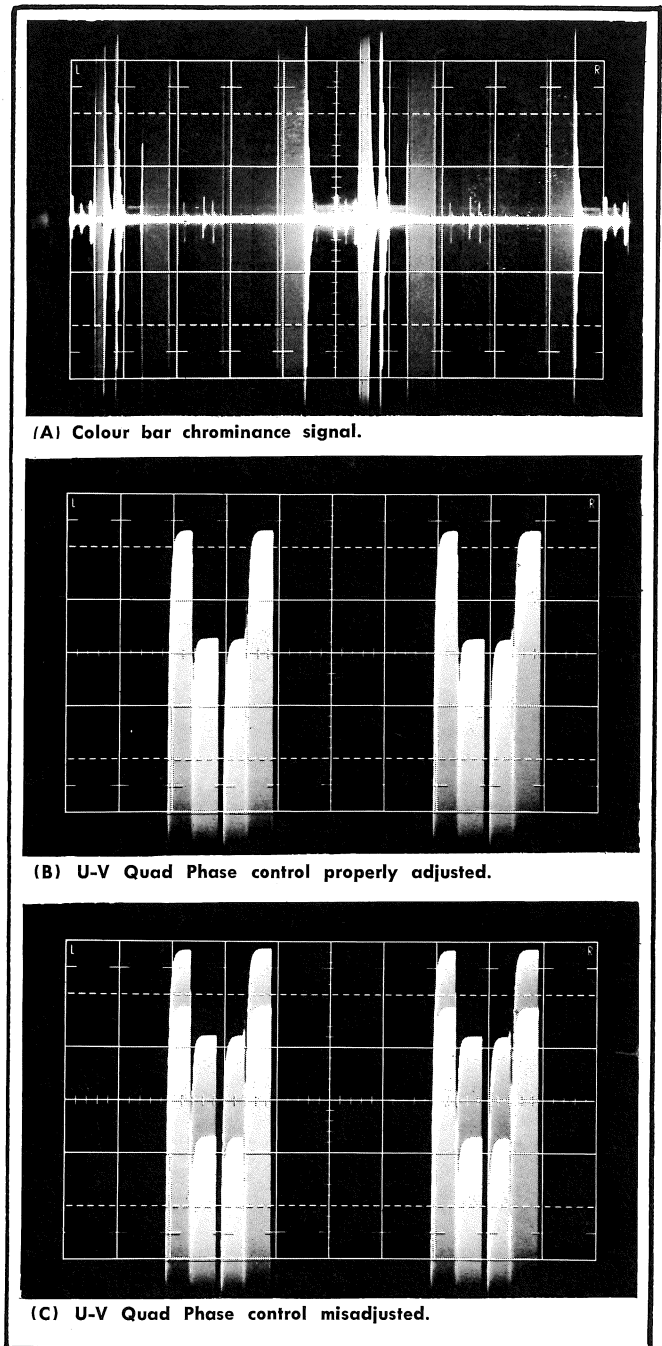
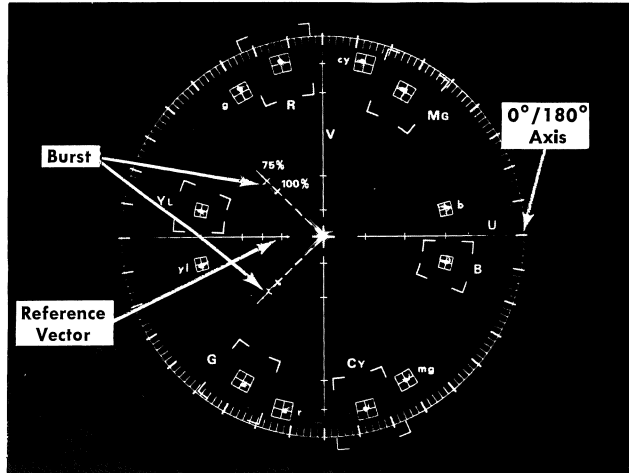

Fig. 5-18. Typical displays showing correct and incorrect adjustment of the U-V Quad Phase control. (Using Voltage Step Up Termination.)

**14. Check/Adjust 180° Switcher**

a. Connect a 75 ohm end-line termination to the Type R520 PAL Channel A J12 connector.

b. From the Type R141A rear-panel COMP VIDEO connector, connect a 75 ohm coaxial cable to the Type R520 PAL Channel A J1 connector.



(A) Burst and reference vectors properly aligned with vector graticule.

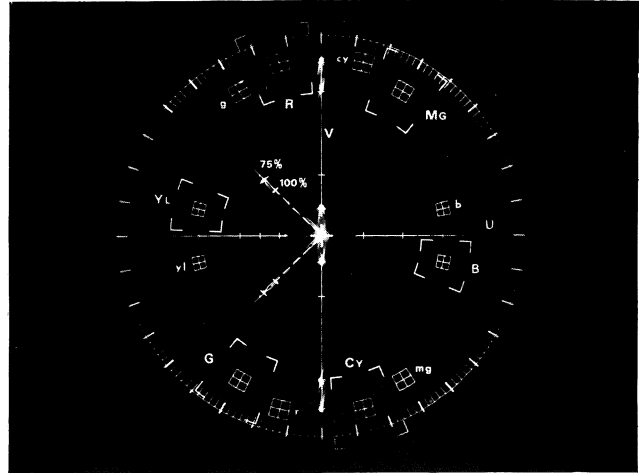

(B) Vectorscope display with V Axis modulations.

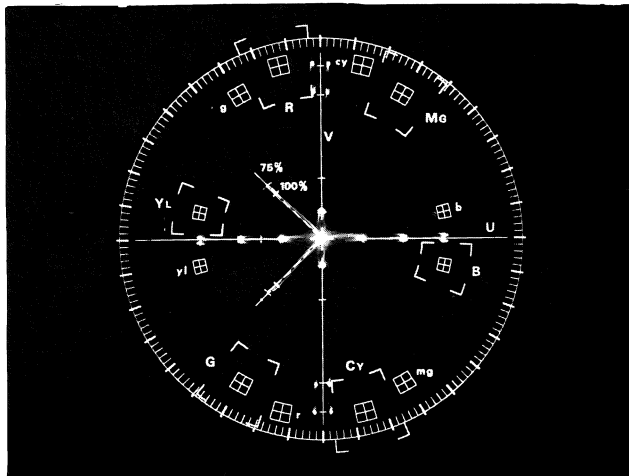

(C) 180° Switcher misadjusted. Photograph was double exposed to show both U and V modulation.

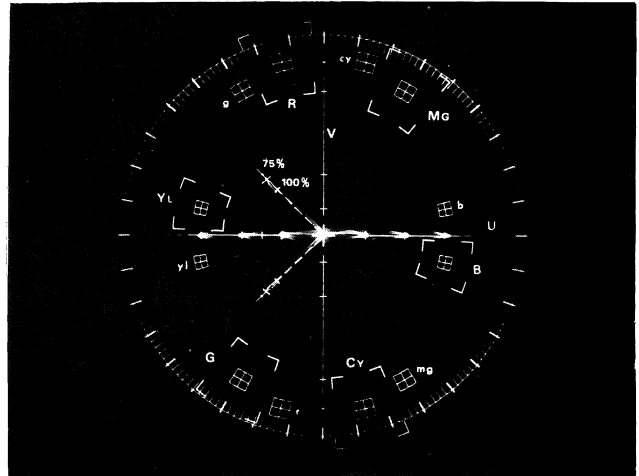

(D) Vectorscope display with U Axis modulation.

Fig. 5-19. Typical Vectorscope displays to check or adjust the 180° Switcher.

c. Rotate the Type R520 PAL Vectorscope A Phase control to align the small vector (located between the burst vectors, as viewed on the Type R520 PAL vector graticule) with the 0°/180° axis of the vector graticule as shown in Fig. 5-19A.

d. Set the Type R141A COLOUR BAR U switch down.

e. CHECK—Type R520 PAL Vectorscope display; dots must overlay as shown in Fig. 5-19B within 0.5°. Also, the dots must lie along the V axis within 0.5°. (See Fig. 5-19C for improper display.)

**NOTE**

Use the Type R520 PAL Vectorscope Calibrated Phase dial to measure the error, if any.

f. Set the Type R141A COLOUR BAR U switch up and V switch down.

g. CHECK—Type R520 PAL Vectorscope display; dots must overlay as shown in Fig. 5-19D within 0.5°. Also, the dots must lie along the U axis within 0.5°.

h. ADJUST—180° Switcher, C645, (see Fig. 5-15) until the requirements of parts e and g are met.

## Performance Check/Calibration—Type 141A/R141A

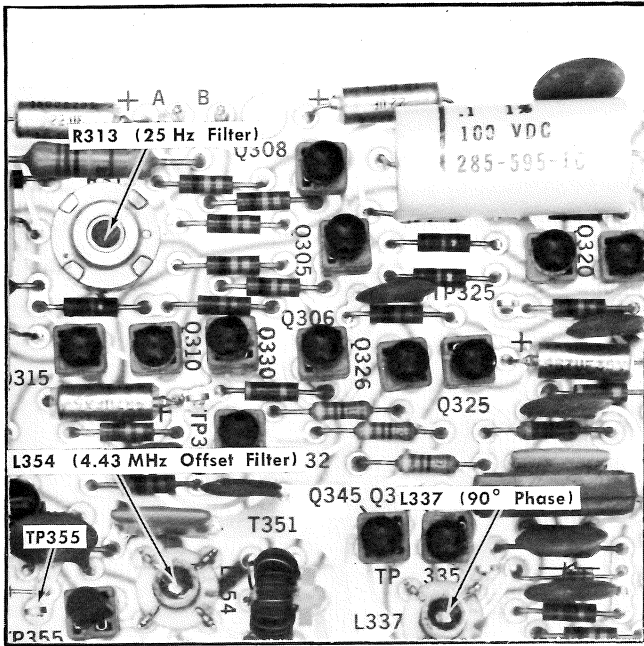

Fig. 5-20. Horiz Colour Lock board adjustment and test point locations.

### NOTE

The adjustment of C645 must be made with either the Type R141A COLOUR BAR U or V switch down, but not both, then repeated with the opposite switch down.

- i. Disconnect the 75 ohm coaxial cable from the Type R141A rear-panel COMP VIDEO connector.
- j. Test equipment remains connected.

## 15. Check Spurious Output

- a. Check that or set the Type R141A COLOUR BAR U and V switches up.
- b. Disconnect the 011-0109-00 Voltage Step Up Termination from the Type 1A5 A Input connector and the 75 ohm coaxial cable from the 011-0109-00 Voltage Step Up Termination; connect a 75 ohm termination to the Type 1A5 A Input connector and the 75 ohm coaxial cable to the 75 ohm termination.
- c. Set the Type 1A5 Comparison Voltage Polarity switch to 0, Volts/Cm switch to .2V, and rotate the Position control to position the bottom of the display (sync tip) to the center graticule line on the test oscilloscope.

d. Rotate the test oscilloscope Horizontal Position control to position the sync tip to the center graticule line on the test oscilloscope.

e. Set the Type 1A5 Comparison Voltage Polarity switch to —, Volts/Cm switch to 10 mV and rotate the Comparison Voltage Amplitude control to position the display (sync tip) to the center graticule line on the test oscilloscope.

f. Set the test oscilloscope Horizontal Display Sweep Magnifier switch to  $\times 10$ .

g. CHECK—Test oscilloscope display; aberrations near center of sync tip must be less than 32 mV peak to peak.

h. Set the test oscilloscope Variable (Time/Cm) control to Calibrated and the Horizontal Display Sweep Magnifier switch to off.

i. Set the Type 1A5 Comparison Voltage Polarity switch to 0.

j. Disconnect the 75 ohm coaxial cable from the Type R141A COMP VIDEO connector and the 75 ohm termination from the Type 1A5 A Input connector.

k. Test equipment remains connected.

## 16. Adjust R313, L337 and L354

a. Connect a 10 $\times$  probe to the Type 1A5 A Input connector.

b. Connect the 10 $\times$  probe to TP355 on the Type R141A Horiz Colour Lock board (see Fig. 5-20).

c. Set the Type 1A5 Volts/Cm switch to 50 mV.

d. Set the test oscilloscope Time Base A Triggering Source switch to Int, Mode Switch to Auto and rotate the Type 1A5 Position control to center the display on the test oscilloscope graticule.

e. ADJUST—25 Hz Filter control, R313; 4.43 MHz Offset Filter adjustment, L354, (see Fig. 5-20) for maximum signal amplitude as measured on the test oscilloscope.

### NOTE

Due to a long time constant involving R313, the effects of adjusting R313 will be slow as observed on the test oscilloscope.

f. Set the test oscilloscope Time Base A Time/Cm switch to 10 ms.

g. ADJUST—90° Phase adjustment, L337, (see Fig. 5-20) for minimum modulation of the display.

h. Set the test oscilloscope Time Base A Time/Cm switch to 10  $\mu$ s.

i. Repeat parts e through g.

j. Disconnect all test equipment and connections.

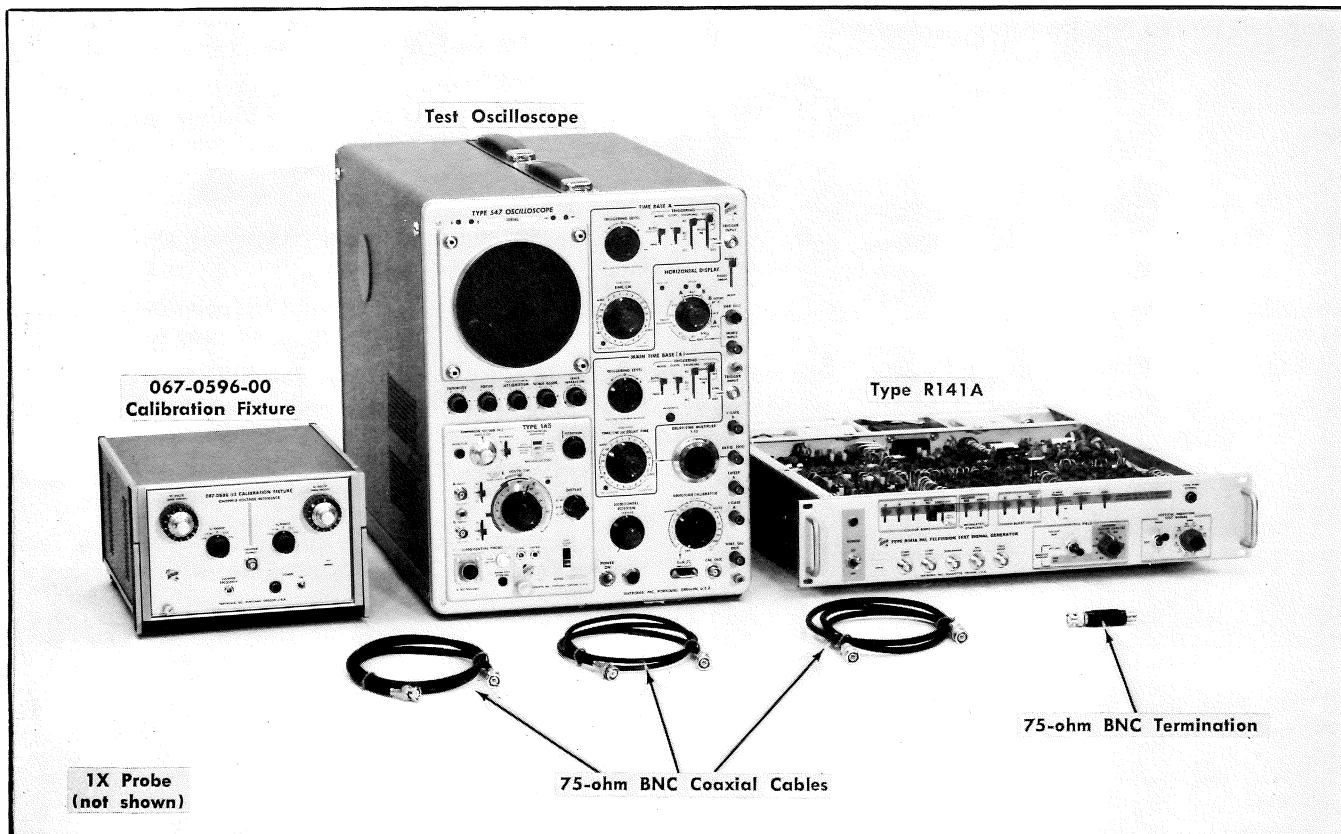

Fig. 5-21. Test equipment required for steps 17 through 31.

**Type R141A Controls**

**COLOUR BARS**

<b>U</b>	Up
<b>V</b>	Up
<b>Y</b>	<b>Down</b>
<b>WHITE REF</b>	Up
<b>AMPLITUDE</b>	75%, 0 SETUP
<b>MODULATED STAIRCASE</b>	
<b>SUBCARRIER MOD</b>	<b>Down</b>
<b>STEPS</b>	<b>Down</b>
<b>BURST</b>	
<b>U</b>	Up
<b>V</b>	Up
<b>BRUCH SEQ</b>	Up
<b>V AXIS PHASING</b>	90° / 270°
<b>25 Hz OFFSET</b>	Up
<b>SYNC</b>	Up
<b>POWER</b>	On
<b>FULL FIELD</b>	
<b>COLOUR BAR/MODU-</b>	<b>COLOUR BAR</b>
<b>LATED STAIRCASE</b>	

<b>AVERAGE PICTURE</b>	12.5
<b>LEVEL</b>	
<b>VERTICAL INSERTION TEST SIGNAL</b>	
<b>FIELD</b>	<b>BOTH</b>
<b>LINE</b>	11/324

**Test Oscilloscope Controls**

<b>Viewing</b>	
Intensity	As desired
Focus	As desired
Astigmatism	As desired
Scale Illum	As desired
Trace Separation	0
<b>Time Base A</b>	
<b>Triggering Level</b>	<b>CW, pushed in</b>
Triggering	
Mode	Auto
<b>Slope</b>	<b>+</b>
<b>Coupling</b>	<b>AC</b>
Source	Norm
<b>Time/Cm</b>	<b>2 μs</b>
Variable (Time/Cm)	Calibrated
<b>Time Base B</b>	



<b>Triggering Level</b>	<b>0, pushed in</b>
Triggering	
<b>Mode</b>	<b>Trig</b>
<b>Slope</b>	<b>—</b>
<b>Coupling</b>	<b>DC</b>
<b>Source</b>	<b>Ext</b>
<b>Time/Cm</b>	<b>20 <math>\mu</math>s</b>
<b>Variable (Time/Cm)</b>	<b>Calibrated</b>
<b>Horizontal Display</b>	<b>B Intens By 'A'</b>
Sweep Magnifier	Off
Single Sweep	Normal
<b>Delay-Time Multiplier</b>	<b>6-30</b>
Horizontal Position	Midrange
Vernier (Horizontal Position)	Midrange
Power	On
Amplitude Calibrator	Off
<b>Type 1A5 Controls</b>	
A Input AC-GND-DC	DC
B Input AC-GND-DC	GND
<b>Volts/Cm</b>	<b>.2 V</b>
Variable (Volts/Cm)	Cal
Display	A-Vc
Position	Midrange
Step Atten Bal	As is
Comparison Voltage	
<b>Amplitude</b>	<b>0-0</b>
Polarity	0
<b>067-0596-00 Calibration Fixture Controls</b>	
<b>V<sub>1</sub></b>	
<b>Range</b>	<b>0</b>
<b>Volts</b>	<b>0-0-0</b>
<b>V<sub>2</sub></b>	
<b>Range</b>	<b>0</b>
<b>Volts</b>	<b>0-0-0</b>
Chopper Frequency	As is
Power	On

**17. Check/Adjust Spurious Subcarrier** ❶

- a. Test equipment is shown in Fig. 5-21.
- b. From the Type R141A COMP VIDEO connector, connect a 75 ohm coaxial cable and a 75 ohm termination to the Type 1A5 A Input connector.

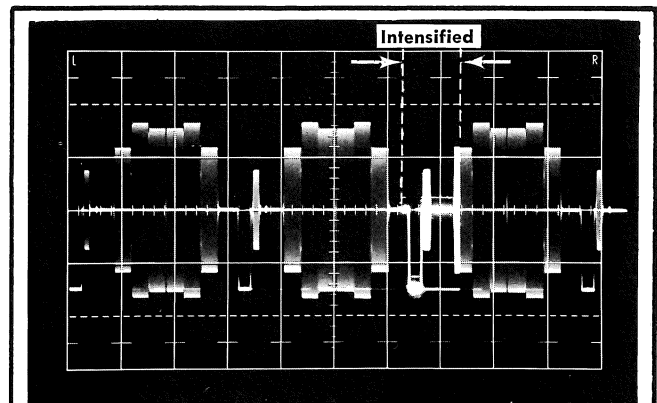

(A) Sync, burst and part of first colour bar intensified.

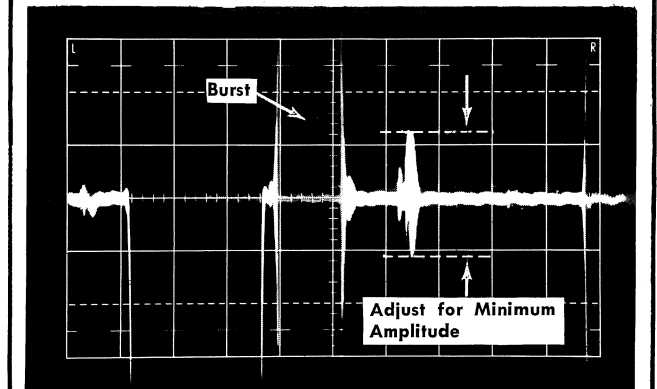

(B) C770 and C787 properly adjusted.

Fig. 5-22. Typical test oscilloscope display using A Dly'd function as a form of magnification.

- c. From the Type R141A rear-panel LINE DRIVE connector, connect a 75 ohm coaxial cable to the test oscilloscope Time Base B Trigger Input connector.
- d. Rotate the test oscilloscope Viewing controls so that the normal and intensified display may be observed.
- e. Observing the test oscilloscope display, rotate the Delay-Time Multiplier control so that sync, burst, and part of the first colour bar are intensified as shown in Fig. 5-22A.
- f. Set the test oscilloscope Horizontal Display switch to A Dly'd.
- g. Set the Type 1A5 Volts/Cm switch to 10 mV.
- h. CHECK—Test oscilloscope display; 4.43 MHz aberration on the display between burst and the first colour bar must be less than or equal to 32 mV peak to peak (see Fig. 5-22B).

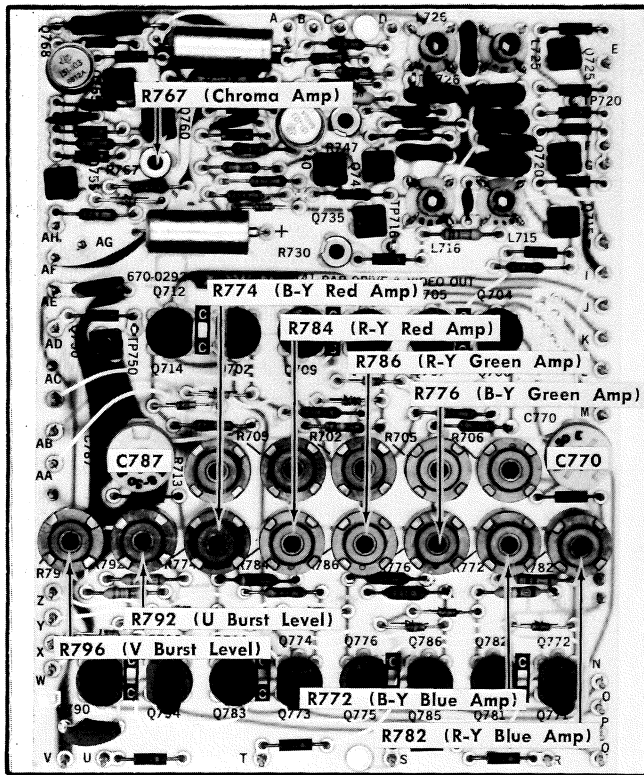

Fig. 5-23. Bar Drive and Video Output board adjustment locations.

i. ADJUST—C770 and C787 (see Fig. 5-23) for minimum aberration (32 mV or less).

**NOTE**

If greater than 32 mV peak to peak, readjust L621 and L671 (see Fig. 5-15) for 32 mV peak to peak.

j. Test equipment remains connected.

**18. Check Chrominance Amplitudes**

a. Set the Type 1A5 Volts/Cm switch to .2 V and the Type R141A COLOUR BAR Y switch up.

b. Set the test oscilloscope Horizontal Display switch to B Intens By 'A' and the Time Base A Time/Cm switch to 1  $\mu$ s.

c. Set the test oscilloscope Delay-Time Multiplier control so that peak white is intensified as shown in Fig. 5-24A.

d. Set the test oscilloscope Horizontal Display switch to A Dly'd.

e. Set the Type 1A5 Volts/Cm switch to 2 mV, Comparison Voltage Polarity switch to +, and rotate the Comparison Voltage Amplitude control to position the intensified portion of the display on the test oscilloscope graticule.

f. CHECK—Test oscilloscope display; chrominance on peak white must be 2.5 mV peak to peak or less (see Fig. 5-24B).

**NOTE**

If part f is not within the listed tolerance, or if any of the following checks are not within the stated tolerance, proceed to Step 19.

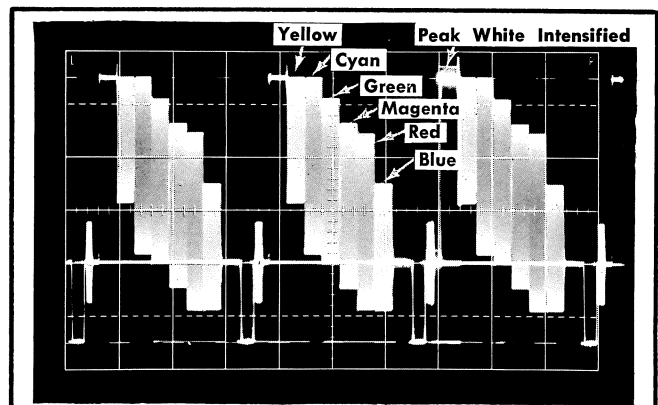

(A) Colour bars with peak white intensified.

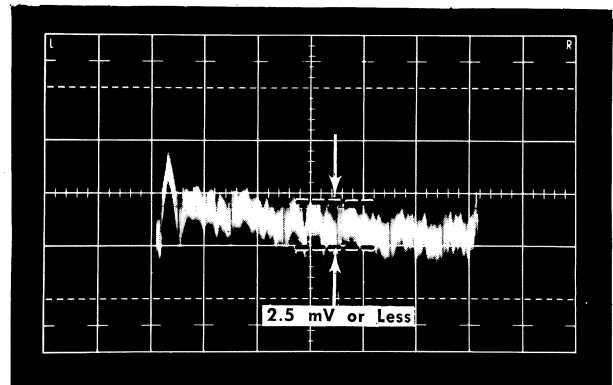

(B) Modulation on peak white.

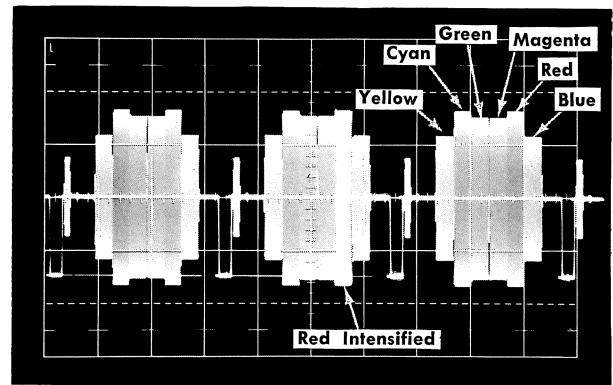

(C) Colour bar chrominance signal with red intensified.

Fig. 5-24. Typical test oscilloscope displays showing location of colour signal components and modulation on peak white.

g. Set the test oscilloscope Horizontal Display switch to B Intens by 'A', and the Time Base A Time/Cm switch to .5  $\mu$ s.

h. Set the Type R141A COLOUR BAR Y and the 25 Hz OFFSET switches down.

i. Set the Type 1A5 Volts/Cm switch to .2 V, Comparison Voltage Polarity switch to 0, and rotate the Position control to center the display on the test oscilloscope.

j. Observing the test oscilloscope display, rotate the Delay-Time Multiplier control until the red colour bar is intensified as shown in Fig. 5-24C.

k. From the 067-0596-00 calibration fixture Chopper Output connector, connect a 75 ohm coaxial cable to the Type 1A5 B Input connector.

l. Set the 067-0596-00 calibration fixture  $V_1$  Range switch to  $-1.1$  V,  $V_2$  Range switch to  $+1.1$  V and  $V_1$  and  $V_2$  Volts controls for a dial setting of 3-3-32 each (663.8 mV).

m. Set the test oscilloscope Horizontal Display switch to A Dly'd.

n. Set the Type 1A5 Volts/Cm switch to 10 mV, Display switch to A-B, B Input AC-GND-DC switch to DC and rotate the Position control to position the display on the test oscilloscope as shown in Fig. 5-25B.

o. Observing the test oscilloscope display, rotate the 067-0596-00 calibration fixture  $V_2$  Volts control until the top of the bottom display just coincides with the bottom of the top display.

p. CHECK—067-0596-00 calibration fixture  $V_2$  Volts control dial setting; dial setting must be between 3-1-32 and 3-5-32 (663.8 mV,  $\pm 3\%$ ).

q. Using the 067-0596-00 calibration fixture  $V_2$  Volts control dial setting obtained in part p, compute and record the percentage error, if any, above or below the standard dial setting for the red colour bar.

**NOTE**

The percentage error computed in this part will be used to determine the error, if any, of the remaining chrominance amplitudes. For example, assume the  $V_2$  Volts control dial settings obtained in part p was 3-1-32 (3% low) or 3-5-32 (3% high).

Add:  $V_1$  and  $V_2$  dial readings obtained in part p

$$\begin{aligned} 333.2 + 313.2 &= 646.4 \text{ or} \\ 333.2 + 353.2 &= 686.4. \end{aligned}$$

Add:  $V_1$  and  $V_2$  Volts control dial settings for the standard value of the red colour bar

$$333.2 + 333.2 = 666.4.$$

Subtract: Total dial settings obtained in part p from the total dial readings for the red colour bar

$$\begin{aligned} 666.4 - 646.4 &= 20.0 \text{ low or} \\ 666.4 - 686.4 &= 20.0 \text{ high.} \end{aligned}$$

% of error:

$$\frac{(20.0) (100)}{666.4} = 3\% \text{ low or high.}$$

r. Set the test oscilloscope Horizontal Display switch to B intens By 'A'.

s. Set the Type 1A5 B Input AC-GND-DC switch to GND, Volts/Cm switch to .2V and rotate the Position control to center the display on the test oscilloscope.

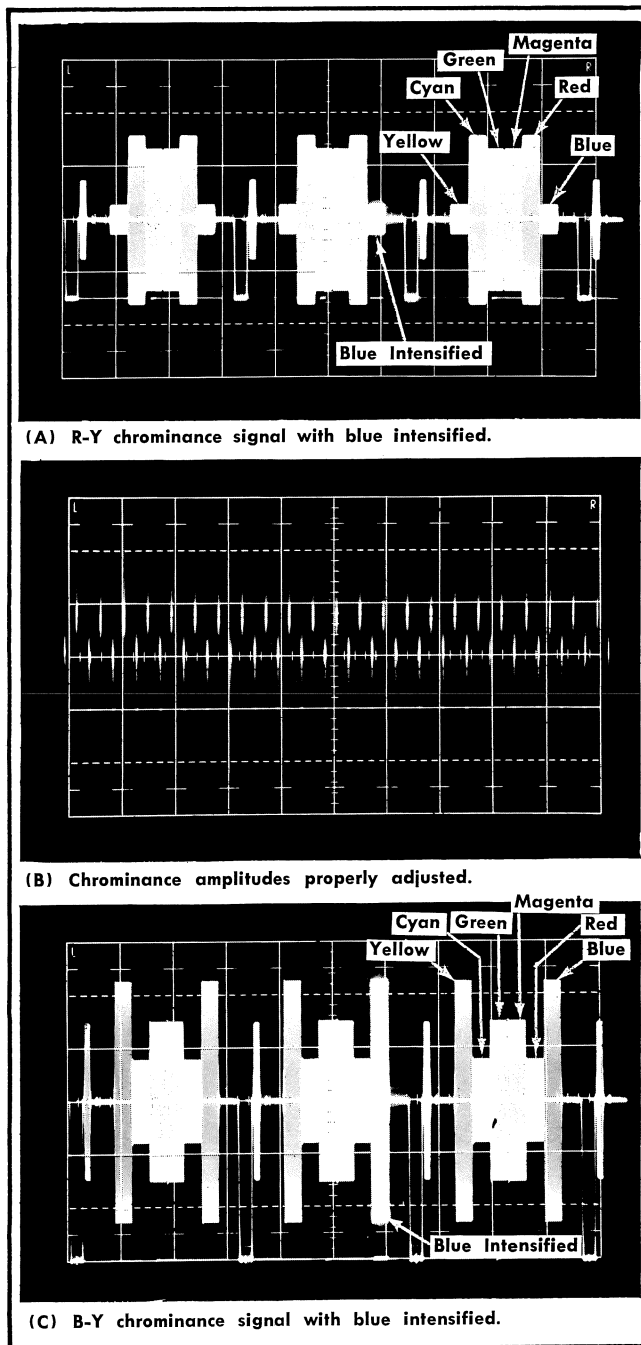

Fig. 5-25. R-Y and B-Y chrominance displays.

t. Observing the test oscilloscope display, rotate the Delay-Time Multiplier control until the blue colour bar is intensified (see Fig. 5-24C).

u. Set the 067-0596-00 calibration fixture  $V_1$  and  $V_2$  Volts control for a dial setting of 2-3-62 each (470.5 mV).

v. Repeat parts m, n, and o.

TABLE 5-2

Colour Intensified (See Fig. 5-24C, Fig. 5-25A <sup>3</sup> and Fig. 5-25C <sup>4</sup> .)	067-0596-00 Calibration Fixture			Tolerance
	V <sub>1</sub> Volts	V <sub>2</sub> Volts	Amplitude P-P	
Magenta	3-1-12	3-1-12	620.1 mV	Absolute ampli- tude of all Subcar- rier frequency com- ponents (Chromin- ance, U, and V) are within 3%.  Relative amplitudes of all Subcarrier frequency compo- nents are within 1% of the red chrominance bar.
Green	3-1-12	3-1-12	620.1 mV	
Cyan	3-3-32	3-3-32	663.8 mV	
Yellow	2-3-61	2-3-61	470.5 mV	
Blue <sup>3</sup>	0-5-26	0-5-26	105.0 mV	
Red <sup>3</sup>	3-2-41	3-2-41	645.5 mV	
Magenta <sup>3</sup>	2-7-13	2-7-13	540.5 mV	
Green <sup>3</sup>	2-7-13	2-7-13	540.5 mV	
Cyan <sup>3</sup>	3-2-41	3-2-41	645.5 mV	
Yellow <sup>3</sup>	0-5-26	0-5-26	105.0 mV	
Blue <sup>4</sup>	2-3-01	2-3-01	458.6 mV	
Red <sup>4</sup>	0-7-76	0-7-76	154.8 mV	
Magenta <sup>4</sup>	1-5-24	1-5-24	303.8 mV	
Green <sup>4</sup>	1-5-24	1-5-24	303.8 mV	
Cyan <sup>4</sup>	0-7-76	0-7-76	154.8 mV	
Yellow <sup>4</sup>	2-3-01	2-3-01	458.6 mV	

<sup>3</sup>Set the Type R141A COLOUR BAR U switch down (R-Y).

<sup>4</sup>Set the Type R141A COLOUR BAR U switch up and the V switch down (B-Y); set the Type 1A5 Volts/Cm switch to .1 V.

w. CHECK—067-0596-00 calibration fixture V<sub>2</sub> Volts control dial setting; dial setting for the blue colour bar must be within 1% of that recorded for the red colour bar in part q, but in no case must the total error for the blue colour bar be greater than 3% above or below the standard dial setting.

**NOTE**

Referring back to the example given following part q, the percentage error was found to be either 3% low or 3% high. With this error, the dial reading obtained in part w would have to be between 2% and 3% below, or between 2% and 3% above, the standard value of the blue colour bar. In other words, the V<sub>2</sub> Volts control dial setting must be between 2-2-29 and 2-2-65

(2% to 3% below), or between 2-4-56 and 2-4-94 (2% to 3% above).

x. Using the procedure just described for checking the amplitude of the blue colour bar, Fig. 5-24C, Fig. 5-25A, B, and C, check each remaining chrominance amplitude listed in Table 5-2.

y. Set the Type R141A COLOUR BAR U and V switches up, and the AMPLITUDE switch to 100%, 0 SETUP.

z. Repeat part i through w for all components listed in Table 5-3.

**NOTE**

All values are different, but procedure is identical.

aa. Test equipment remains connected.

**NOTES**

---

---

---

---

---

---

---

---

---

---

TABLE 5-3

Colour Intensified	067-0596-00 Calibration Fixture			Tolerance	
	V <sub>1</sub> Volts	V <sub>2</sub> Volts	Amplitude P-P		
Red (see Tolerance)	4-4-42	4-4-42	885.1 mV	Absolute amplitude of all Subcarrier frequency components (Chrominance, U, and V) are within 3%.	
Blue	3-1-52	3-1-52	627.3 mV		
Magenta	4-1-52	4-1-52	826.8 mV		
Green	4-1-52	4-1-52	826.8 mV		
Cyan	4-4-42	4-4-42	885.1 mV		
Yellow	3-1-52	3-1-52	627.3 mV		
Blue <sup>5</sup>	0-7-02	0-7-02	140.0 mV		
Red <sup>5</sup>	8-6-45	8-6-45	860.7 mV		
Magenta <sup>5</sup>	3-6-20	3-6-20	720.7 mV		
Green <sup>5</sup>	3-6-20	3-6-20	720.7 mV		
Cyan <sup>5</sup>	8-6-45	8-6-45	860.7 mV		
Yellow <sup>5</sup>	0-7-02	0-7-02	140.0 mV		
Blue <sup>6</sup>	3-0-68	3-0-68	611.5 mV		Relative amplitudes of all Subcarrier frequency components are within 1% of the red chrominance bar.
Red <sup>6</sup>	1-0-31	1-0-31	206.4 mV		
Magenta <sup>6</sup>	2-0-33	2-0-33	405.1 mV		
Green <sup>6</sup>	2-0-33	2-0-33	405.1 mV		
Cyan <sup>6</sup>	1-0-31	1-0-31	206.4 mV		
Yellow <sup>6</sup>	3-0-68	3-0-68	611.5 mV		

<sup>5</sup>Set the Type R141A COLOUR BAR U switch down (R-Y).

<sup>6</sup>Set the Type R141A COLOUR BAR U switch up and the V switch down (B-Y); set the Type 1A5 Volts/Cm switch to .1 V.

## 19. Adjust Chrominance Amplitudes ①

a. Set the Type 1A5 Volts/Cm switch to .2V and the B Input AC-GND-DC switch to GND, and the Polarity switch to 0, if necessary.

b. Set the test oscilloscope Horizontal Display switch to B Intens By 'A'.

c. Set the Type R141A COLOUR BAR U, V, WHITE REF and AMPLITUDE switches up and the COLOUR BAR Y and the 25 Hz OFFSET switches down.

d. Rotate the Type 1A5 Position control to center the display on the test oscilloscope.

e. Observing the test oscilloscope display, rotate the Delay-Time Multiplier control so that the red colour bar is intensified (see Fig. 5-24C).

f. Check that the 067-0596-00 calibration fixture V<sub>1</sub> Range switch is set at -1.1 V, V<sub>2</sub> Range switch is set at +1.1 V, then set the V<sub>1</sub> and V<sub>2</sub> Volts controls for a dial setting of 3-3-32 each (663.8 mV) then, if necessary, connect a 75 ohm coaxial cable from the Chopped Output connector to the Type 1A5 B Input connector.

g. Set the test oscilloscope Horizontal Display switch to A Dly'd.

h. Set the Type 1A5 Volts/Cm switch to 10 mV, B Input AC-GND-DC switch to DC, Display switch to A-B, if necessary, and rotate the Position control to position the display as shown in Fig. 5-25B.

i. ADJUST—Chroma Amp control, R767, (see Fig. 5-23) until the top of the bottom display just coincides with the bottom of the top display.

### NOTE

Final adjustment of R767 will be performed in Step 36.

j. Repeat part b.

k. Set the Type 1A5 Volts/Cm switch to .2V, B Input AC-GND-DC switch to GND and the Position control to midrange.

l. Set the Type R141A COLOUR BAR U switch down.

TABLE 5-4

Component Intensified (see Fig 5-25A and Fig. 5-25C.)		067-0596-00 Calibration Fixture			Type R141A Adjustment
		V <sub>1</sub> Volts	V <sub>2</sub> Volts	Amplitude (P-P)	
Red	(R-Y)	3-2-41	3-2-41	645.5 mV	R784
Green	(R-Y)	2-7-13	2-7-13	540.5 mV	R786
Blue <sup>†</sup>	(B-Y)	2-3-01	2-3-01	458.6 mV	R772
Red <sup>†</sup>	(B-Y)	0-7-75	0-7-75	154.7 mV	R774
Green <sup>†</sup>	(B-Y)	1-5-24	1-5-24	303.8 mV	R776

<sup>†</sup>Set the Type R141A COLOUR BAR U switch up and the V switch down; set the Type 1A5 Volts/Cm switch to .1 V.

m. Rotate the Type 1A5 Position control to center the display on the test oscilloscope.

n. Observing the test oscilloscope display, rotate the Delay-Time Multiplier control so that the blue component of the R-Y signal is intensified as shown in Fig. 5-25A.

o. Set the 067-0596-00 calibration fixture V<sub>1</sub> and V<sub>2</sub> Volts controls for a dial setting of 0-5-26 each (105.0 mV).

p. Repeat part g.

q. Set the Type 1A5 Volts/Cm switch to 10 mV, B Input AC-GND-DC switch to DC and rotate the Position Control to position the display as shown in Fig. 5-25B.

r. ADJUST—R-Y Blue Amp control, R782, (see Fig. 5-23) until the top of the bottom display just coincides with the bottom of the top display.

s. Using the procedure just described for adjusting the blue component of the R-Y signal (Fig. 5-23 and Fig. 5-25A and B, adjust the remaining R-Y components of the chrominance signal listed in Table 5-4.

t. Repeat parts a and b.

u. Set the Type R141A COLOUR BAR Y switch up; set the Type 1A5 Comparison Voltage Polarity switch to +, Comparison Voltage Amplitude control to 0-0 and the Display switch to A-Vc.

v. Observing the test oscilloscope display, set the Delay-Time Multiplier control so that peak white is intensified.

w. Set the Type 1A5 Volts/Cm switch to 2 mV and rotate the Comparison Voltage Amplitude control to position peak white within the viewing area of the test oscilloscope graticule.

x. READJUST—R-Y Red Amp control, R784; R-Y Green Amp control, R786, for a null of the chroma on peak white. (Disregard transients).

y. Set the Type 1A5 Volts/Cm switch to .2 V, Display switch to A-B, and the Comparison Voltage Polarity switch to 0.

z. Repeat part b.

aa. Set the Type R141A COLOUR BAR U switch up and the COLOUR BAR V and Y switches down.

ab. Observing the test oscilloscope display, set the Delay-Time Multiplier control such that the blue component of the B-Y signal is intensified as shown in Fig. 5-25C.

ac. Set the 067-0596-00 calibration fixture V<sub>1</sub> and V<sub>2</sub> Volts controls for dial settings of 2-3-01 each (458.6 mV).

ad. Repeat parts g and h.

ae. ADJUST—B-Y Blue Amp control, R772, (see Fig. 5-23) until the top of the bottom display just coincides with the bottom of the top display.

af. Using the procedure just described for adjusting the blue component of the B-Y signal, Fig. 5-23, and Fig. 5-25B and C, adjust the remaining B-Y components of the chrominance signal listed in Table 5-4.

ag. Repeat parts (in listed order) a, b, u, v, and w.

ah. READJUST—B-Y Blue Amp control, R772; B-Y Green Amp control, R776, for a null of the chroma on peak white. (Disregard transients.)

ai. Repeat parts y and z.

aj. Set the Type R141A COLOUR BAR V switch up.

ak. PERFORM STEP 18 BEFORE PROCEEDING TO STEP 20.

al. Test equipment remains connected.

## 20. Check/Adjust Burst Amplitude ①

a. Set the Type R141A BURST U switch and the COLOUR BAR U, V, and Y switches down, and the AMPLITUDE switch to 75%, 0 SETUP.

b. Set the test oscilloscope Horizontal Display switch to B Intens By 'A'.

c. Set the Type 1A5 Volts/Cm switch to .1 V, B Input AC-GND-DC switch to GND and rotate the Position control to center the display on the test oscilloscope.

d. Observing the test oscilloscope display, rotate the Delay-Time Multiplier control so that the V component of burst is intensified as shown in Fig. 5-26A.

e. Set the 067-0596-00 calibration fixture  $V_1$  and  $V_2$  Volts controls for a dial setting of 1-0-62 each (212 mV).

f. Set the test oscilloscope Horizontal Display switch to A Dly'd.

g. Set the Type 1A5 B Input AC-GND-DC switch to DC, Volts/Cm switch to 10 mV, and rotate the Position control to position the display as shown in Fig. 5-26B.

h. Observing the test oscilloscope display, rotate the 067-0596-00 calibration fixture  $V_2$  Volts control until the top of the bottom display just coincides with the bottom of the top display.

i. CHECK—067-0596-00 calibration fixture  $V_2$  Volts control dial setting; dial setting must be between 0-9-68 and 1-1-57 (212 mV,  $\pm 3\%$ ).

j. Set the 067-0596-00 calibration fixture  $V_2$  Volts control for a dial setting of 1-0-62.

k. ADJUST—V Burst Level control, R796, (see Fig. 5-23) until the top of the bottom display just coincides with the bottom of the top display.

l. Set the Type R141A BURST U switch up and the V switch down.

m. Repeat parts h, i and j.

n. ADJUST—U Burst Level control, R792, (see Fig. 5-23) until the top of the bottom display just coincides with the bottom of the top display.

o. Set the Type 1A5 Volts/Cm switch to .1 V and the B Input AC-GND-DC switch to GND.

p. Set the Type R141A BURST V switch up.

q. Rotate the 067-0596-00 calibration fixture  $V_1$  and  $V_2$  Volts controls for dial settings of 1-5-05 each (300 mV).

r. Set the Type 1A5 Volts/Cm switch to 10 mV and the B Input AC-GND-DC switch to DC.

s. Observing the test oscilloscope display, rotate the 067-0596-00 calibration fixture  $V_2$  Volts control until the top of the bottom display just coincides with the bottom of the top display.

t. CHECK—067-0596-00 calibration fixture  $V_2$  Volts control dial setting; dial setting must be between 1-4-55 and 1-6-04 (300 mV,  $\pm 3\%$ ).

u. Set the Type 1A5 Volts/Cm switch to 50 mV and the B Input AC-GND-DC switch to GND.

v. Set the test oscilloscope Horizontal Display switch to B Intens by 'A'.

w. Rotate the Type 1A5 Variable (Volts/Cm) control for an amplitude of 5 cm, as measured on the test oscilloscope,

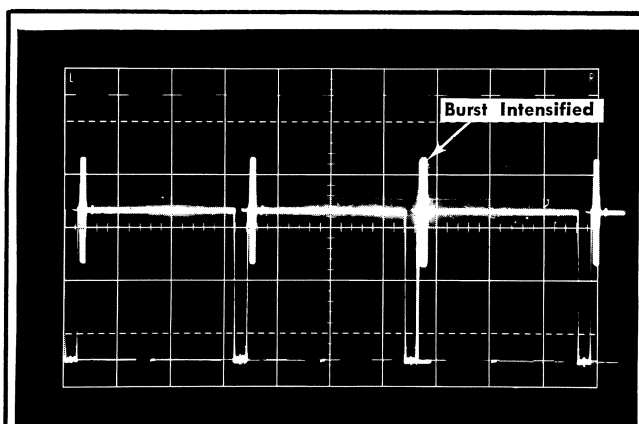

(A) Burst waveform with burst intensified.

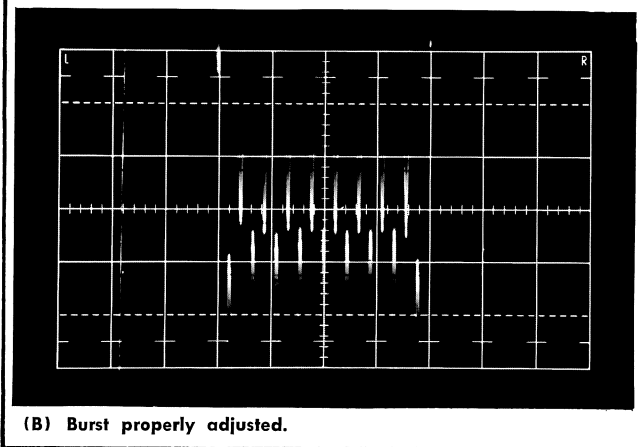

(B) Burst properly adjusted.

Fig. 5-26. Typical burst displays obtained when checking or adjusting burst amplitude.

between the positive and negative peaks of that burst in the center of the display (e.g., there will be three burst packets, one on the left and one on the right, of the burst set for exactly 5 cm in amplitude).

x. Set the Type R141A 25 Hz OFFSET switch up.

y. CHECK—Test oscilloscope display; amplitude of burst packets to the left and right of that burst exactly 5 cm in amplitude must be between 97% and 100% of 5 cm.

z. Test equipment remains connected.

## 21. Check/Adjust Setup Level

### NOTE

Throughout the Performance Check/Calibration procedure, if only a Performance check is being performed, the Type R141A top and bottom covers are not removed, (Exception, see step 6 and 39). To accurately check or adjust the setup level, access to the Type R141A Horiz Detail Timing board is necessary. Remove the top cover, perform the step, then replace the cover.

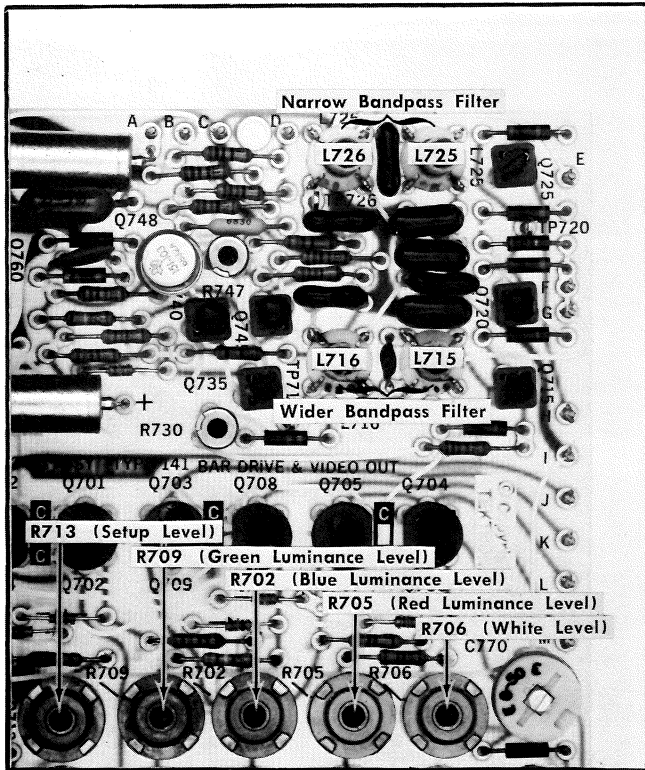
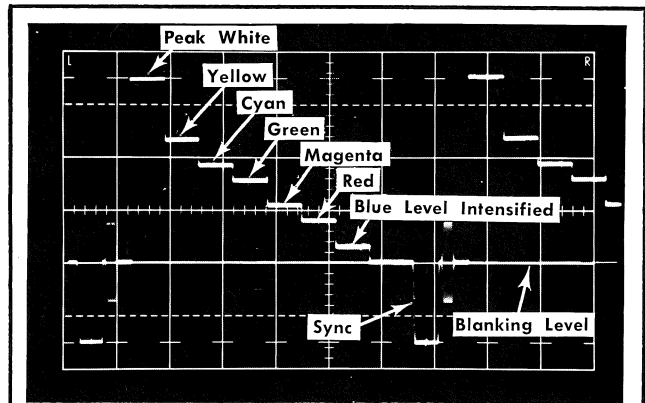
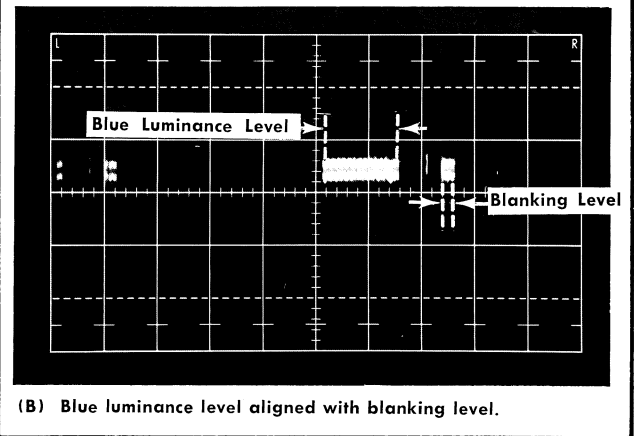

Fig. 5-27. Bar Drive and Video Output board adjustment locations.

- a. Set the Type R141A POWER switch to OFF.
- b. Disconnect pin connector "K" on the Type R141A Horiz Detail Timing board (see Fig. 5-12.)
- c. Set the Type R141A Power switch On.
- d. Set the Type R141A COLOUR BAR AMPLITUDE switch to 75%, 25% SETUP.
- e. Set the Type 1A5 B Input AC-GND-DC switch to GND, Volts/Cm switch to .2 V, and the Variable (Volts/Cm) switch to Cal. Rotate the Position control to align the blanking level of the display with the center graticule line of the test oscilloscope.
- f. Set the test oscilloscope Horizontal Display switch to B and the Time Base B Time/Cm switch to 10  $\mu$ s.
- g. Rotate the test oscilloscope Time Base B Variable (Time/Cm) control to display two lines of video.
- h. Set the 067-0596-00 calibration fixture V<sub>2</sub> Range switch to +1.1 V and rotate the V<sub>2</sub> Volts control for a dial setting of 1-7-56 (175 mV).
- i. Set the Type 1A5 B Input AC-GND-DC switch to DC and the Volts/Cm switch to 10 mV.
- j. Observing the test oscilloscope display, rotate the 067-0696-00 calibration fixture V<sub>2</sub> Volts control until the setup level is superimposed on the blanking level.



(A) Luminance component of colour bars.



(B) Blue luminance level aligned with blanking level.

Fig. 5-28. Typical displays used to check or adjust luminance levels.

- k. CHECK—067-0596-00 calibration fixture V<sub>2</sub> Volts control dial setting; dial setting must be between 1-7-38 and 1-7-73 (175 mV,  $\pm 1\%$ ).
- l. Adjust the 067-0596-00 calibration fixture V<sub>2</sub> Volts control for a dial setting of exactly 1-7-56.
- m. ADJUST—Setup Level control, R713, (see Fig. 5-27) until setup is superimposed on the blanking level.
- n. Set the Type R141A POWER switch OFF.
- o. Disconnect pin connector "H" on the Type R141A Horiz Detail Timing board and reconnect it to pin 'K'.
- p. Install the Type R141A top cover, then set the POWER switch ON.
- q. Test equipment remains connected.

## 22. Check/Adjust Colour Bar Luminance Level Amplitudes

- a. Set the Type 1A5 B Input AC-GND-DC switch to GND, and the Volts/Cm switch to .2 V.
- b. Set the 067-0596-00 calibration fixture V<sub>2</sub> Volts control for a dial setting of 0-5-99 (59.8 mV).



TABLE 5-5

Luminance Level	067-0596-00 Calibration Fixture		Type R141A Adjustment
	V <sub>2</sub> Volts	Tolerance. ( ± 1% )	
Green	3-0-93 (308.2 mV)	3-0-62 to 3-1-24	R709
Magenta	2-1-75 (216.8 mV)	2-1-53 to 2-1-97	- - -
Cyan	3-6-96 (368.0 mV)	3-6-95 to 3-7-33	- - -
Yellow	4-6-74 (465.2 mV)	4-6-28 to 4-7-21	- - -
Peak White	7-0-28 (700.0 mV)	6-9-58 to 7-1-00	R706
White <sup>8</sup>	5-2-75 (525.0 mV)	5-2-22 to 5-3-28	- - -

<sup>8</sup>Set the Type R141A COLOUR BAR WHITE REF switch down (return switch to up position after completion of check).

c. Set the Type R141A COLOUR BAR Y, U, and V switches down and the AMPLITUDE switch to 75%, 0% SETUP.

d. Set the test oscilloscope Time Base B Variable (Time/Cm) control to Calibrated. Display will be similar to Fig. 5-28A.

e. Set the Type 1A5 Volts/Cm switch to 10 mV and rotate the position control to position the blanking level of the display to the center graticule line on the test oscilloscope.

f. Set the Type 1A5 B Input AC-GND-DC switch to DC.

g. Observing the test oscilloscope display, rotate the 067-0596-00 calibration fixture V<sub>2</sub> Volts control until the blue luminance level aligns with the blanking level as shown in Fig. 5-28B. (See Fig. 5-28A for location of luminance levels.)

h. CHECK—067-0596-00 calibration fixture V<sub>2</sub> Volts control dial setting; dial setting must be between 0-5-93 and 0-6-06 (59.8 mV, ±1%).

i. Set the 067-0596-00 calibration fixture V<sub>2</sub> Volts control for a dial setting of 0-5-99.

j. ADJUST—Blue Luminance Level control, R702, (see Fig. 5-27) until the blue luminance level aligns with the blanking level.

k. Observing the test oscilloscope display, rotate the 067-0596-00 calibration fixture V<sub>2</sub> Volts control until the red luminance level aligns with the blanking level.

l. CHECK—067-0596-00 calibration fixture V<sub>2</sub> Volts control dial setting; dial setting must be between 1-5-59 and 1-5-91 (157.0 mV, ±1%).

m. Set the 067-0596-00 calibration fixture V<sub>2</sub> Volts control for a dial setting of 1-5-75 (157.0 mV).

n. ADJUST—Red Luminance Level control, R705, (see Fig. 5-27) until the red luminance level aligns with the blanking level.

o. Using the procedure just described for checking or adjusting the blue and red luminance levels, Fig. 5-27, and Fig. 5-28A and B, check and/or adjust all remaining luminance levels (in listed order) listed in Table 5-5.

p. Set the Type R141A COLOUR BAR AMPLITUDE switch to 100%, 0 SETUP.

q. Using the procedure just described for checking luminance amplitudes in the 75%, 0 SETUP condition, and Table 5-6, check all luminance amplitudes for 100%, 0 SETUP.

NOTE

If any of the levels are not within listed tolerances, repeat parts a through q.

TABLE 5-6

Luminance Level	067-0596-00 Calibration Fixture		Tolerance ( ± 1% )
	V <sub>2</sub> Volts	Amplitude	
Blue	0-8-00	79.8 mV	0-7-90 to 0-8-10
Red	2-0-99	209.3 mV	2-0-78 to 2-1-21
Magenta	2-9-01	289.1 mV	2-8-73 to 2-9-30
Green	4-1-26	410.9 mV	4-0-84 to 4-1-68
Cyan	4-9-28	490.7 mV	4-8-79 to 4-9-76
Yellow	6-2-31	620.2 mV	6-1-68 to 6-2-94
White	7-0-28	700.0 mV	6-9-58 to 7-1-00

r. Set the Type R141A COLOUR BAR AMPLITUDE switch to 75%, 25% SETUP.

s. Using the procedure just described for checking luminance amplitude in the 100%, 0 SETUP condition, and Table 5-7, check all luminance amplitudes for 75%, 25% SETUP.

TABLE 5-7

Luminance Level	067-0596-00 Calibration Fixture		Tolerance ( ± 1% )
	V <sub>1</sub> Volts	Amplitude	
Blue	2-3-57	234.8 mV	2-3-33 to 2-3-81
Red	3-3-34	332.0 mV	3-3-01 to 3-3-68
Magenta	3-9-33	391.8 mV	3-8-94 to 3-9-72
Green	4-8-53	483.2 mV	4-8-05 to 4-9-01
Cyan	5-4-57	543.0 mV	5-4-02 to 5-5-12
Yellow	6-4-34	640.2 mV	6-3-69 to 6-4-98
White	7-0-28	700.0 mV	6-9-58 to 7-1-00

t. Test equipment remains connected.

23. Check/Adjust Peak White Aberrations and Risetime

a. Set the Type 1A5 Volts/Cm switch to .2V and the B Input AC-GND-DC switch to GND.

b. Set the test oscilloscope Horizontal Display switch to B Intens by 'A'.

c. Set the Type R141A COLOUR BAR AMPLITUDE switch to 75%, 0 SETUP.

## Performance Check/Calibration—Type 141A/R141A

d. Set the test oscilloscope Delay-Time Multiplier control so that peak white is intensified; set the Horizontal Display switch to A Dly'd.

e. Check that the Type 1A5 Position control is set to mid-range and the Comparison Voltage Amplitude control is set to 0-0. Set the Comparison Voltage Polarity switch to +, Volts/Cm switch to 50 mV and the Display switch to A-Vc.

f. Rotate the Type 1A5 Comparison Voltage Amplitude control and the Variable (Volts/Cm) control for a 5 cm display, as measured on the test oscilloscope, between peak white and the blanking level as shown in Fig. 5-29A.

g. CHECK—Test oscilloscope display; aberrations on top leading-corner of the display must be no greater than  $\pm 2\%$  of the 5 cm display.

h. Set the test oscilloscope Horizontal Display Sweep Magnifier switch to  $\times 10$ .

i. CHECK—Test oscilloscope display; risetime must be 100 ns within 10% (see Fig. 5-29B).

j. ADJUST—Wide Bandpass Filter adjustments, L715 and L716, (see Fig. 5-27) for a risetime of 100 ns or less with aberrations within  $\pm 2\%$ .

k. Test equipment remains connected.

## 24. Check/Adjust Staircase Level Amplitudes

a. Set the Type R141A COLOUR BAR U and V switches up, MODULATED STAIRCASE STEPS switch up and the FULL FIELD COLOUR BAR/MODULATED STAIRCASE switch to 50% APL.

b. Set the test oscilloscope Time Base B Time/Cm switch to  $5 \mu\text{s}$ , Sweep Magnifier switch off and the Display switch to B.

c. Set the Type 1A5 Volts/Cm Switch to .2 V, Variable (Volts/Cm) switch to CAL and the Polarity Switch to 0.

d. Set the 067-0596-00 Calibration Fixture  $V_2$  Volts control for a dial setting of 1-4-04.

e. Rotate the test oscilloscope Time Base B Variable (Time/Cm) control for exactly one line of video as shown in Fig. 5-30A.

f. Set the Type 1A5 B Input AC-GND-DC switch to DC, Volts/Cm switch to 10 mV, and the Display Switch to A-B.

g. Observing the test oscilloscope display, rotate the 067-0596-00 calibration fixture  $V_2$  Volts control until the first staircase level exactly aligns with the blanking level of the display as shown in Fig. 5-30B.

h. CHECK—067-0596-00 calibration fixture  $V_2$  Volts control dial setting; dial setting must be between 1-3-90 and 1-4-18 (140 mV,  $\pm 1\%$ ).

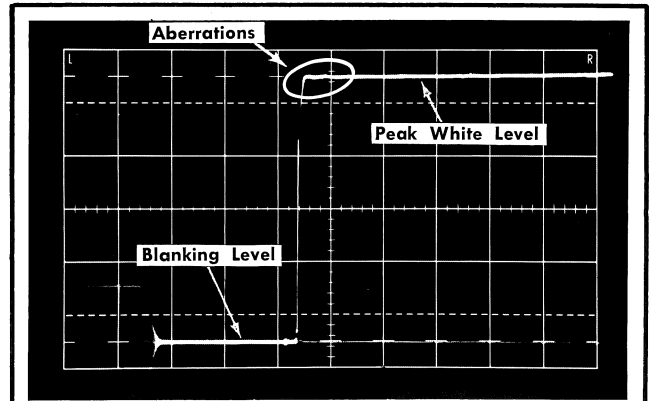

(A) Checking aberrations on peak white.

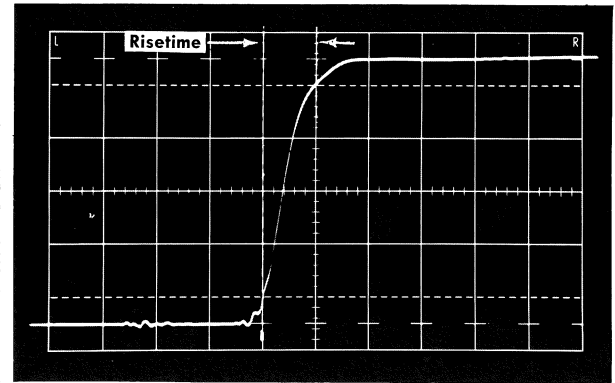

(B) Checking peak white risetime.

Fig. 5-29. Typical displays to check or adjust peak white risetime and aberrations.

### NOTE

Parts h through z checks each step of the staircase signal for 140 mV,  $\pm 1\%$  between steps. Parts ab and ac check the overall amplitude of the staircase signal. For complete calibration, proceed to part ad.

i. Set the 067-0596-00 calibration fixture  $V_2$  Volts control for a dial setting of exactly 1-4-04.

j. Set the 067-0596-00 calibration fixture  $V_1$  Range switch to +1.1 V.

k. Rotate the 067-0596-00 calibration fixture  $V_1$  Volts control for a dial setting of exactly 1-4-04.

### NOTE

When the 067-0596-00 calibration fixture Volts controls are set for identical dial settings, the display on the test oscilloscope appear as one.

l. Rotate the 067-0596-00 calibration fixture  $V_2$  Volts control for a dial setting of exactly 2-8-11 (280 mV).

## Performance Check/Calibration—Type 141A/R141A

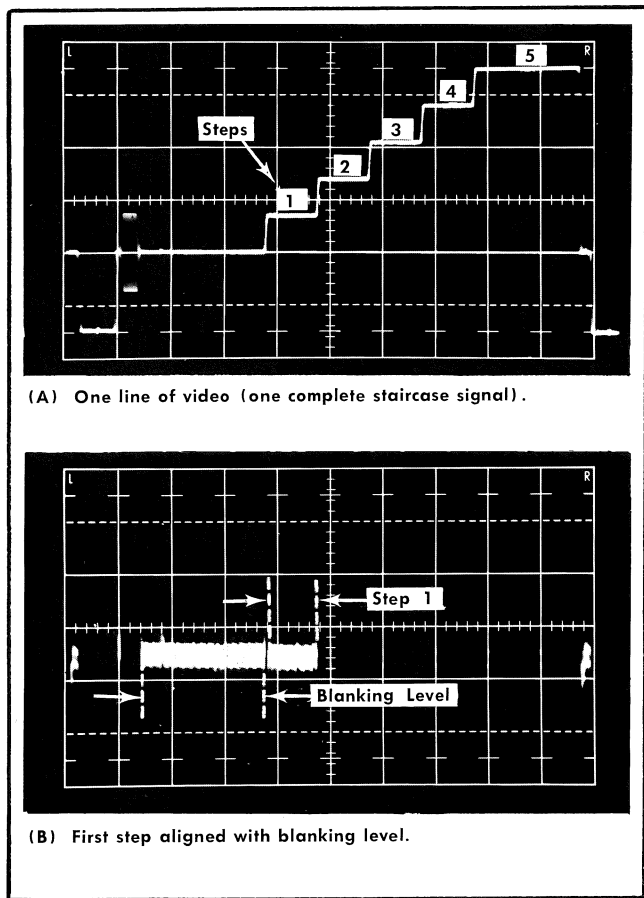

Fig. 5-30. Typical displays used to check or adjust the staircase signal.

m. Observing the test oscilloscope display, rotate the 067-0596-00 calibration fixture  $V_1$  Volts control until the first step exactly aligns with the second step.

n. CHECK—067-0596-00 calibration fixture  $V_1$  Volts control dial setting; dial setting must be between 1-3-90 and 1-4-18. (Amplitude between step 1 and 2; 140 mV,  $\pm 1\%$ .)

o. Set the 067-0596-00 calibration fixture  $V_1$  Volts control for a dial setting of exactly 2-8-11.

p. Set the 067-0596-00 calibration fixture  $V_2$  Volts control for a dial setting of exactly 4-2-19 (420 mV).

q. Observing the test oscilloscope display, rotate the 067-0596-00 calibration fixture  $V_1$  Volts control until the second step aligns with the third step.

r. CHECK—067-0596-00 calibration fixture  $V_1$  Volts control dial setting; dial setting must be between 2-7-97 and 2-8-25. (Amplitude between step 2 and step 3; 140 mV,  $\pm 1\%$ .)

s. Set the 067-0596-00 calibration fixture  $V_1$  Volts control for a dial setting of exactly 4-2-19.

t. Set the 067-0596-00 calibration fixture  $V_2$  Volts control for a dial setting of exactly 5-6-28.

u. Observing the test oscilloscope display, rotate the 067-0596-00 calibration fixture  $V_1$  Volts control until the third step aligns with the fourth step.

v. CHECK—067-0596-00 calibration fixture  $V_1$  Volts control dial setting; dial setting must be between 4-2-04 and 4-2-33. (Amplitude between step 3 and step 4; 140 mV,  $\pm 1\%$ .)

w. Set the 067-0596-00 calibration fixture  $V_1$  Volts control for a dial setting of exactly 5-6-28.

x. Set the 067-0596-00 calibration fixture  $V_2$  Volts control for a dial setting of exactly 7-0-28 (700 mV).

y. Observing the test oscilloscope display, rotate the 067-0596-00 calibration fixture  $V_1$  Volts control until the fourth step aligns with the fifth step.

z. CHECK—067-0596-00 calibration fixture  $V_1$  Volts control dial setting; dial setting must be between 5-6-14 and 5-6-42. (Amplitude between step 4 and step 5, 140 mV,  $\pm 1\%$ .)

aa. Set the 067-0596-00 calibration fixture  $V_1$  Range switch to 0.

ab. Observing the test oscilloscope display, rotate the 067-0596-00 calibration fixture  $V_2$  Volts control until the fifth step exactly aligns with the blanking level.

ac. CHECK—067-0596-00 calibration fixture  $V_2$  Volts control dial setting; dial setting must be between 6-9-59 and 7-1-00 (700 mV,  $\pm 1\%$ .)

### NOTE

Parts ad through an apply only as a calibration procedure. For performance check, proceed to part ao.

ad. Rotate the 067-0596-00 calibration fixture  $V_2$  Volts control for a dial setting of exactly 1-4-04.

ae. ADJUST—Step 1 Level control, R531, (see Fig. 5-31) until the first step aligns with the blanking level as shown in Fig. 5-30B.

af. Repeat part ad, using a dial setting of 2-8-11.

ag. ADJUST—Step 2 Level control, R536, until the second step aligns with the blanking level.

ah. Repeat part ad, using a dial setting of 4-2-19.

ai. ADJUST—Step 3 Level control, R541, until the third step aligns with the blanking level.

aj. Repeat part ad, using a dial setting of 5-6-28.

ak. ADJUST—Step 4 Level control, R546, until the fourth step aligns with the blanking level.

al. Repeat part ad, using a dial setting of 7-0-28.

am. ADJUST—Step 5 Level control, R526, until the fifth step aligns with the blanking level.

an. Do parts d through ac before proceeding to part ao.

ao. Set the Type 1A5 B Input AC-GND-DC switch to GND and the Volts/Cm switch to .2 V.

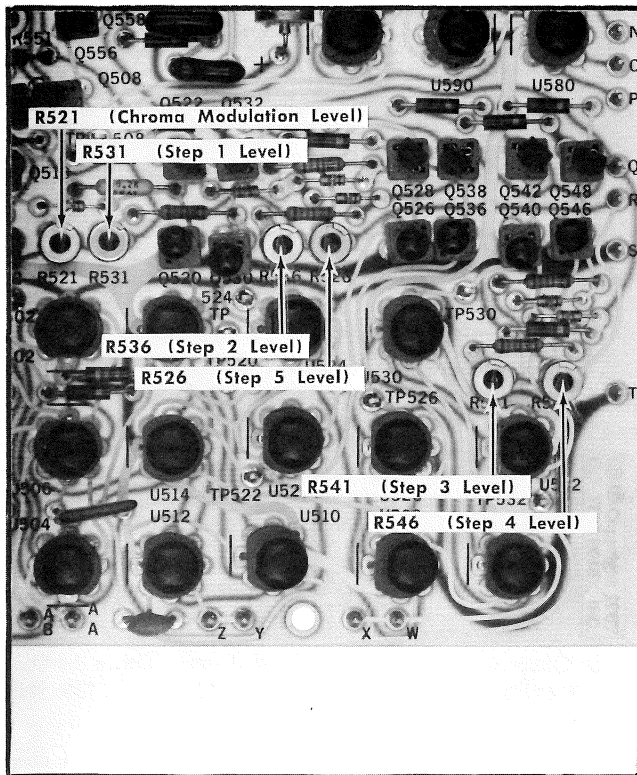

Fig. 5-31. Staircase board adjustment locations.

ap. Test equipment remains connected.

## 25. Check/Adjust Staircase Modulation Amplitude

a. Set the Type R141A MODULATED STAIRCASE SUB-CARRIER MOD switch to up and the 25 Hz OFFSET switch down.

b. CHECK—Test oscilloscope display; 4.43 MHz modulation must be present on the staircase signal.

c. Set the test oscilloscope Horizontal Display switch to B Intens by 'A' and the Time Base A Time/Cm switch to .5  $\mu$ s.

d. Adjust the test oscilloscope Delay-Time Multiplier control so that the intensified portion of the display is centered on the 2nd and 3rd staircase level as shown in Fig. 5-32A.

e. Set the test oscilloscope Horizontal Display switch to A Dly'd.

f. Set the 067-0596-00 calibration fixture  $V_2$  Volts control for a dial setting of 1-4-04 (140 mV).

g. Set the Type 1A5 B Input AC-GND-DC switch to DC, Volts/Cm switch to 50 mV, and rotate the Position control to position the display on the test oscilloscope as shown in Fig. 5-32B.

h. Set the test oscilloscope Horizontal Display Sweep Magnifier switch to  $\times 2$ .

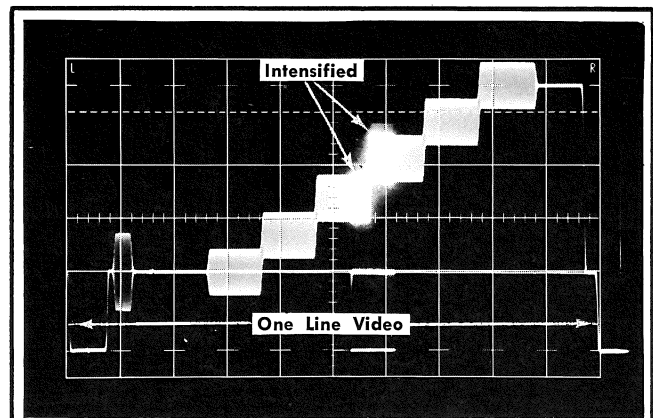

(A) Steps two and three intensified.

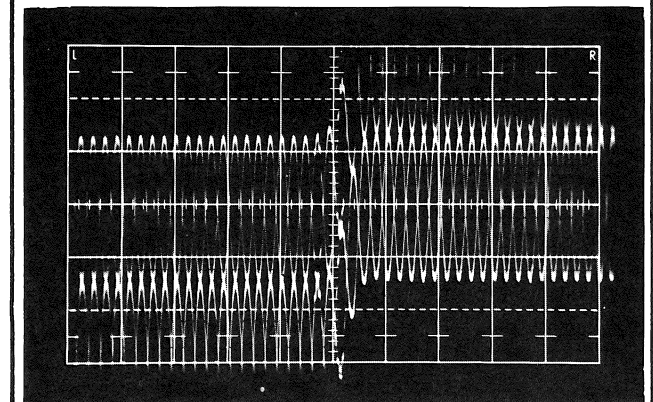

(B) Staircase modulation properly adjusted.

Fig. 5-32. Typical displays to check or adjust staircase modulation.

i. Observing the test oscilloscope display, rotate the 067-0596-00 calibration fixture  $V_2$  Volts control until the top of the bottom display just coincides with the bottom of the top display.

j. CHECK—067-0596-00 calibration fixture  $V_2$  Volts control dial setting; dial setting must be between 1-3-62 and 1-4-47 (140 mV,  $\pm 3\%$ ).

k. Set the 067-0596-00 calibration fixture  $V_2$  Volts control for a dial setting of exactly 1-4-04.

l. ADJUST—Chroma Modulation Level control, R521 (see Fig. 5-31) until the top of the bottom display coincides with the bottom of the top display.

m. Test equipment remains connected.

## 26. Check Staircase Modulation Risetime and Duration

a. Set the Type 1A5 B Input AC-GND-DC switch to GND, Volts/Cm switch to .2 V, Display switch to A-Vc, and rotate the Position control to center the display on the test oscilloscope.

b. Set the Type R141A 25 Hz OFFSET switch up and the MODULATED STAIRCASE STEPS switch down.

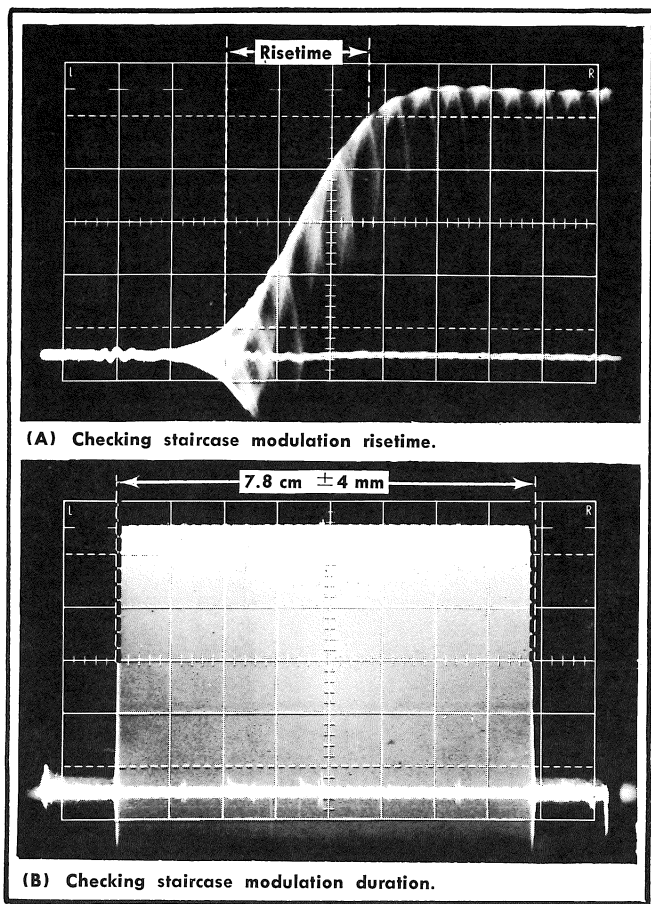

Fig. 5-33. Typical displays to check staircase modulation risetime and duration.

c. Set the test oscilloscope Horizontal Display switch to B Intens by 'A' and rotate the Delay-Time Multiplier control so that the intensified portion of the display lies on the leading edge of the modulation envelope.

d. Set the test oscilloscope Horizontal Display switch to A Dly'd, and the Time Base B Variable (Time/Cm) switch to Calibrated.

e. Rotate the Type 1A5 Position control to midrange and set the Comparison Voltage Polarity switch to +.

f. Set the Type 1A5 Volts/Cm switch to 10 mV and rotate the Comparison Voltage Amplitude and Variable (Volts/Cm) controls for a display 5 cm in amplitude, as indicated on the test oscilloscope, between the start of the modulation and the most positive excursion of the modulation.

g. Set the test oscilloscope Horizontal Display switch to  $\times 5$ .

h. CHECK—Test oscilloscope display; risetime must be 260 ns within 15%. (See Fig. 5-33A.)

i. Set the test oscilloscope Horizontal Display switch to B and the Sweep Magnifier switch to  $\times 2$ .

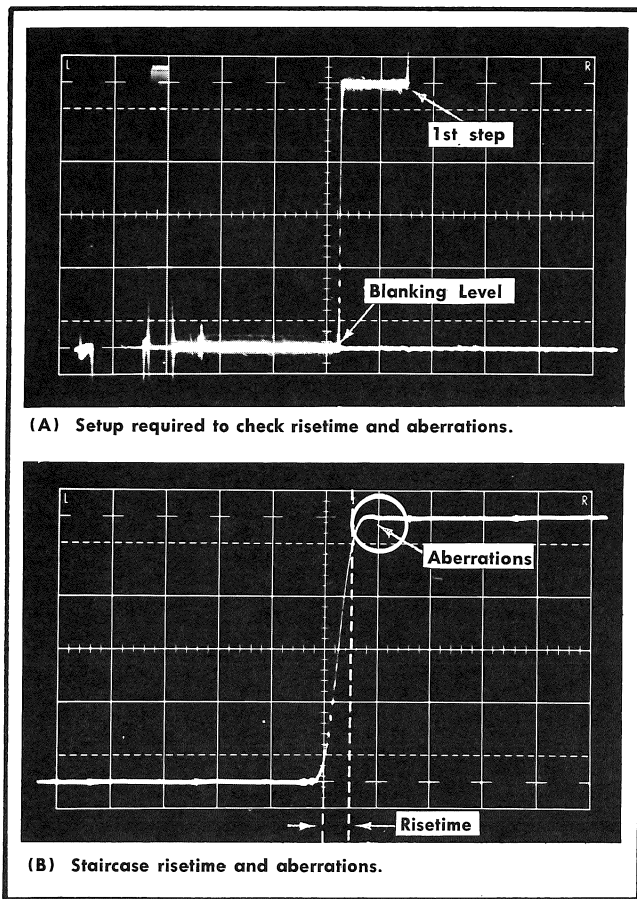

Fig. 5-34. Typical displays to check or adjust staircase risetime and aberrations.

j. CHECK—Test oscilloscope display; duration of modulation must be 7.8 cm within 4 mm (see Fig. 5-33B).

k. Test equipment remains connected.

## 27. Check/Adjust Staircase Risetime and Aberrations

a. Set the Type R141A MODULATED STAIRCASE SUB-CARRIER MOD switch down and the STEPS switch up.

b. Set the test oscilloscope Horizontal Display Sweep Magnifier switch to OFF.

c. Rotate the Type 1A5 Comparison Voltage Amplitude and Variable (Volts/Cm) controls for a display amplitude of 5 cm, as indicated on the test oscilloscope, between the blanking level and the first step of the display.

d. Set the test oscilloscope Time Base B Time/Cm switch to  $5 \mu s$ , rotate the Horizontal Position control to position the rising portion of the first step as in Fig. 5-34A, then set the Sweep Magnifier switch to  $\times 10$ .

e. CHECK—Test oscilloscope display; risetime must be 260 ns within 15%, as shown in Fig. 5-34B.

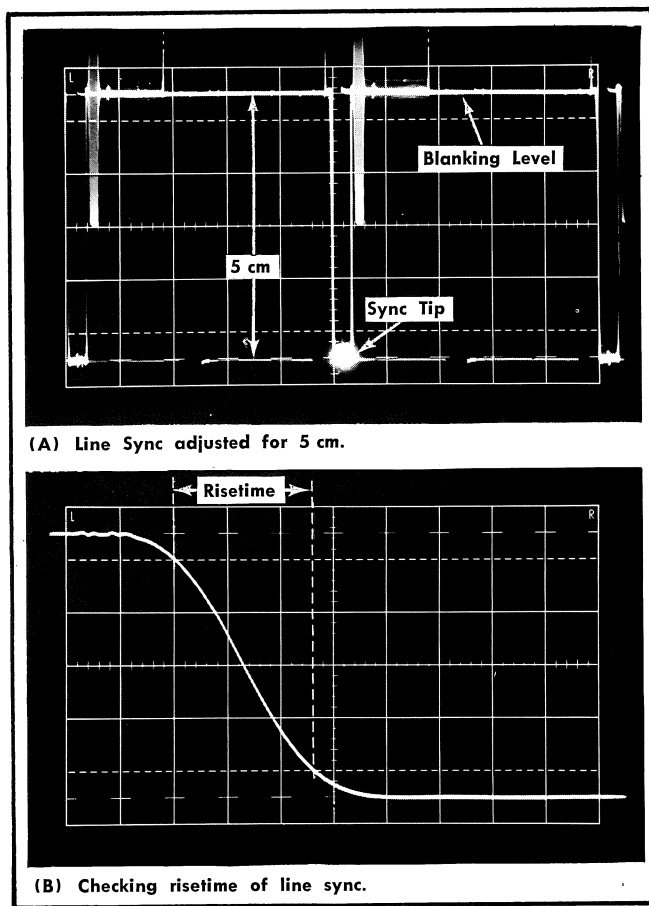

Fig. 5-35. Typical displays to check line sync risetime.

- f. CHECK—Test oscilloscope display; aberrations on top corner of leading edge of the display must be less than  $\pm 2\%$  (of 5 cm display) as shown in Fig. 5-34B.
- g. ADJUST—Narrow Bandpass Filter adjustments, L725 and L726, (see Fig. 5-27) for a risetime of 260 ns within 15% with aberrations less than  $\pm 2\%$ .
- h. Test equipment remains connected.

### 28. Check Line Sync Risetime

- a. Set the test oscilloscope Horizontal Display switch to B Intens By 'A', Sweep Magnifier switch to Off and the Time Base B Time/Cm switch to 10  $\mu$ s.
- b. Set the Type 1A5 Volts/Cm switch to .2V, and the Variable (Volts/Cm) control to Cal.
- c. Observing the test oscilloscope display, rotate the Time Base B Variable Time/Cm control to display 2 complete lines, then, rotate the Delay-Time Multiplier control such that the sync pulse is intensified.

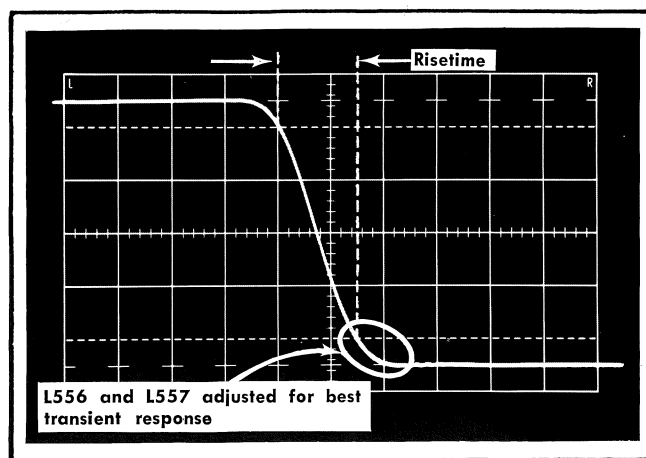

Fig. 5-36. Comp Sync waveform adjusted for proper transient response.

- d. Set the Type 1A5 Comparison Voltage Polarity switch to —, Volts/Cm switch to 50 mV, and the Comparison Amplitude and Variable (Volts/Cm) controls for a display amplitude of 5 cm, as measured on the test oscilloscope, between the blanking level and the sync tip as shown in Fig. 5-35A.
- e. Set the test oscilloscope Horizontal Display switch to A Dly'd, and the Sweep Magnifier switch to  $\times 5$ .
- f. CHECK—Test oscilloscope display; risetime must be between 230 ns and 290 ns (see Fig. 5-35B).
- g. Test equipment remains connected.

### 29. Check Comp Sync Amplitude and Outputs

- a. Set the test oscilloscope Time Base B Variable (Time/Cm) switch to Calibrated, Horizontal Display switch to B and the Sweep Magnifier switch to off.
- b. Set the Type 1A5 Volts/Cm switch to 1V, Variable (Volts/Cm) to Cal, and the Polarity Switch to 0.
- c. Disconnect the 75 ohm coaxial cable from the Type R141A COMP VIDEO Connector and reconnect it to the COMP SYNC connector.
- d. Use the Position controls to center the display on the test oscilloscope.
- e. CHECK—Test oscilloscope display; display amplitude must be 4 volts peak to peak,  $\pm 0.2$  V.
- f. Disconnect the 75 ohm coaxial cable from the Type R141A COMP SYNC connector and reconnect it to the Type R141A rear-panel COMP SYNC connector.
- g. CHECK—Test oscilloscope display; display amplitude must be 4 volts peak to peak,  $\pm 0.2$  V.
- h. Test equipment remains connected.

### 30. Adjust Comp Sync Transient Response and Risetime ①

a. Set the test oscilloscope Time Base B Time/Cm switch to  $.5 \mu\text{s}$ , Horizontal Display Sweep Magnifier switch to  $\times 5$  and rotate the Horizontal Position control to position the negative portion of the display to the center of the test oscilloscope graticule.

b. Set the Type 1A5 Volts/Cm switch to  $.5\text{V}$  and rotate the Position and Variable (Volts/Cm) controls for a display amplitude of 5 cm as indicated on the test oscilloscope and shown in Fig. 5-36.

c. CHECK—Test oscilloscope display; risetime must be 260 ns within 15% and transient response must be similar to that shown in Fig. 5-36.

d. ADJUST—Comp Sync Filter adjustments, L556 and L557, (see Fig. 5-37) for the best transient response of composite sync.

e. Test equipment remains connected.

### 31. Check/Adjust Output Amplifiers ①

a. Set the Type 1A5 Volts/Cm switch to 1 V and the Variable (Volts/Cm) Control to Cal.

b. Set the test oscilloscope Time Base B Triggering Source switch to Int, Time/Cm switch to  $10 \mu\text{s}$  and the Sweep Magnifier switch off.

c. Disconnect the 75 ohm coaxial cable from the Type R141A rear-panel LINE DRIVE connector and the test oscilloscope Time Base B Trigger Input connector.

d. Disconnect the 75 ohm coaxial cable from the Type R141A rear-panel COMP SYNC connector and reconnect it to the rear-panel LINE DRIVE connector.

e. CHECK—Test oscilloscope display; display amplitude must be 4 volts peak to peak within 0.2 Volt.

f. Set the test oscilloscope Sweep Magnifier switch to X10.

g. Set the Type 1A5 Volts/Cm switch to  $.5\text{V}$  and rotate the Variable (Volts/Cm) control for a display amplitude of 5 cm.

h. CHECK—Test oscilloscope display; rise- and fall-time of pulse must be 260 ns within 15%.

i. Set the test oscilloscope Sweep Magnifier switch to X5.

j. ADJUST—L924 and L925 (see Fig. 5-38), for the best square corners on leading and trailing edges of the display.

k. Disconnect the 75 ohm coaxial cable from the Type R141A rear-panel LINE DRIVE connector and reconnect it to the rear-panel FIELD DRIVE connector.

l. Repeat part a.

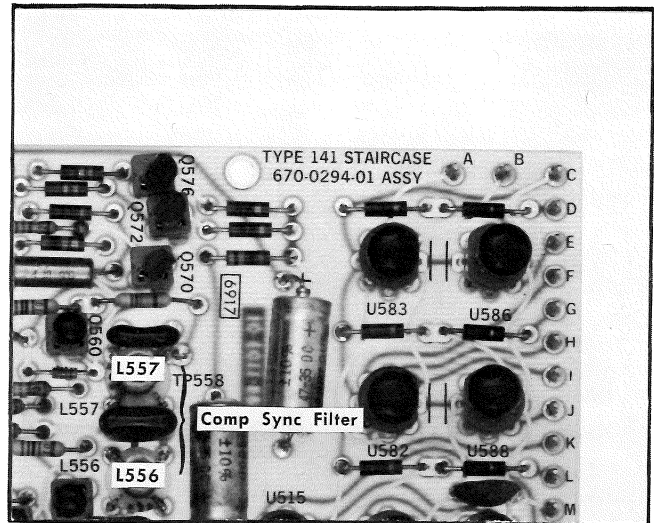

Fig. 5-37. Staircase board adjustment location.

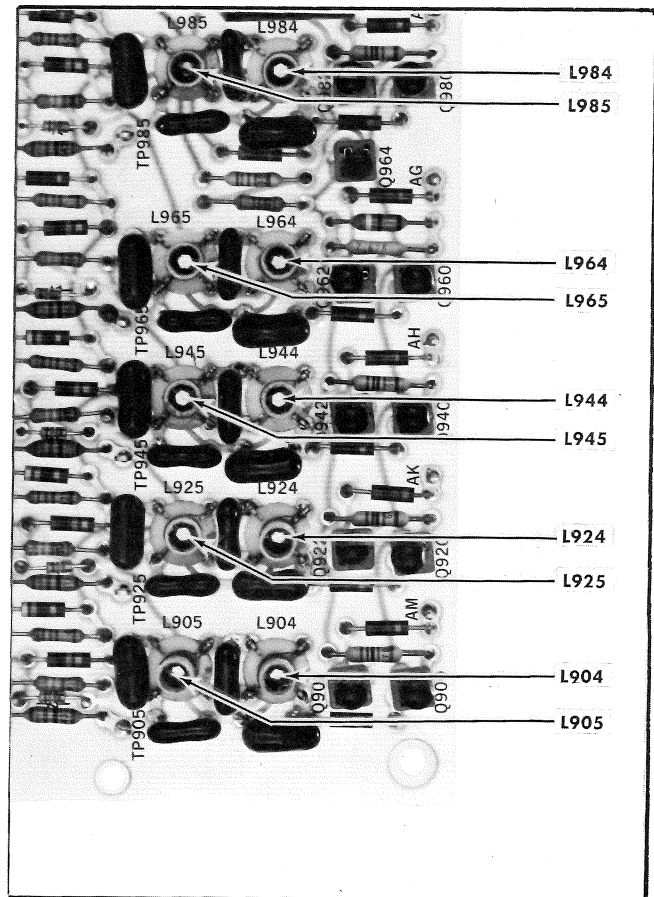

Fig. 5-38. Output Amplifier board adjustment locations.



## Performance Check/Calibration—Type 141A/R141A

m. Set the test oscilloscope Time Base B Time/Cm switch to 5 ms and the Sweep Magnifier switch off.

n. Repeat part e.

o. Disconnect the 75 ohm coaxial cable from the Type R141A rear-panel FIELD DRIVE connector and reconnect it to the FIELD DRIVE connector.

p. Repeat part e.

q. Set the test oscilloscope Sweep Magnifier Switch to X10.

r. ADJUST—L984 and L985 for least amount of spiking on the corners of the leading and trailing edges of the pulse.

s. Disconnect the 75 ohm coaxial cable from the Type R141A FIELD DRIVE connector and reconnect it to the rear-panel COMP BLANKING connector.

t. Set the test oscilloscope Time Base B Time/Cm switch to 10  $\mu$ s.

u. Repeat part e.

v. Set the test oscilloscope Sweep Magnifier switch to X10.

w. Repeat parts g, h and i.

x. ADJUST—L944 and L945, for the best square corners on the leading and trailing edges of the pulse.

y. Disconnect the 75 ohm coaxial cable from the Type R141A rear-panel COMP BLANKING connector and reconnect it to the rear-panel BURST FLAG connector.

z. Set the test oscilloscope Sweep Magnifier switch off.

aa. Repeat parts a, e, f, g, and h.

ab. ADJUST—L904 and L905 for the best square corners on leading and trailing edges of the pulse.

ac. Disconnect the 75 ohm coaxial cable from the Type R141A rear-panel BURST FLAG connector and reconnect it to the rear-panel PAL PULSE connector.

### NOTE

Depending on internal connections, the display obtained at the PAL PULSE output connector may or may not check as described due to different test equipment control settings. Refer to the Specification and Operating Instruction portions of this manual for details.

ad. Repeat (in listed order) parts z, a and e.

ae. Disconnect the 75 ohm coaxial cable from the Type R141A rear-panel PAL PULSE connector and reconnect it to the PAL PULSE connector.

af. Repeat (in listed order) e, f and g.

ag. ADJUST—L964 and L965, for the best square corners on the leading and trailing edges of the display.

ah. Disconnect all test equipment and connections.

### NOTES

---

---

---

---

---

---

---

---

---

---

---

---

---

---

---

---

---

---

---

---

---

---

---

---



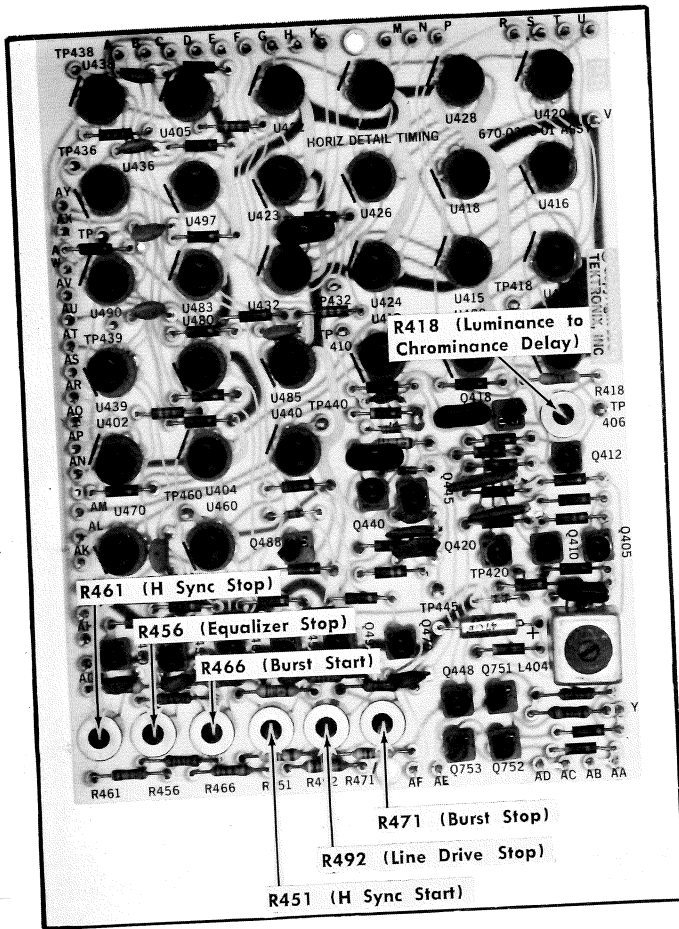
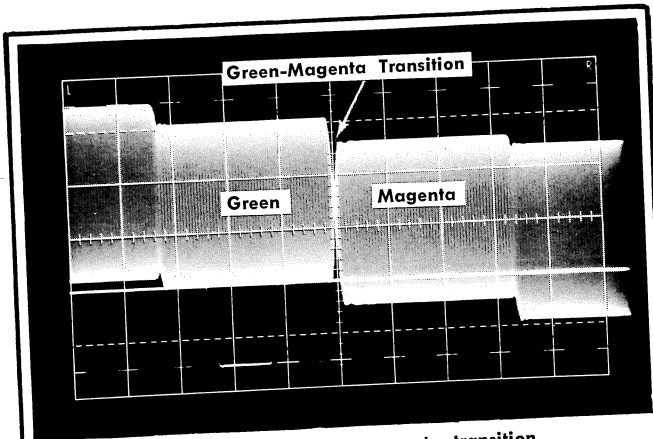
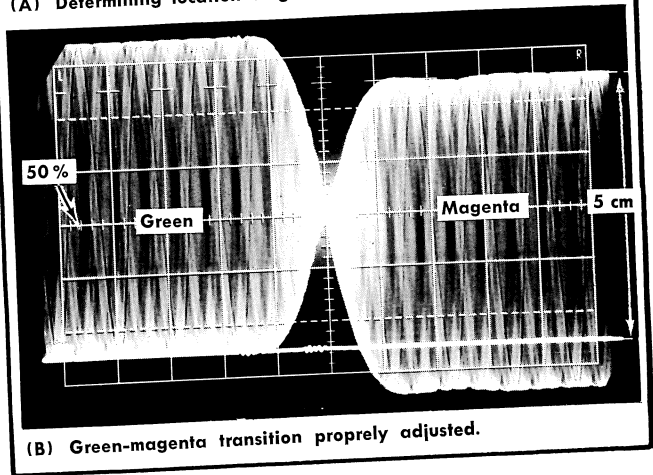

Fig. 5-41. Horiz Detail Timing board adjustment locations.

- j. Disconnect the 75 ohm coaxial cable from the Type R141A rear-panel LINE DRIVE connector and reconnect it to the COMP VIDEO connector.
- k. From the Type R141A rear-panel LINE DRIVE connector, connect a 75 ohm coaxial cable to the test oscilloscope Time Base B Trigger Input connector.
- l. Set the Type 1A5 Volts/Cm switch to .2V and rotate the Type 1A5 Position control to center the display on the test oscilloscope.
- m. Set the test oscilloscope Horizontal Display switch to B Intens by 'A', then rotate the test oscilloscope Time Base B Triggering Level control for a triggered display.



(A) Determining location of green-magenta transition.



(B) Green-magenta transition properly adjusted.

Fig. 5-42. Typical displays to check or adjust luminance to chrominance delay.

- n. Set the test oscilloscope Delay-Time Multiplier control so that the intensified portion of the display is as shown in Fig. 5-40B.
- o. Set the test oscilloscope Horizontal Display switch to A Dly'd.
- p. Using Table 5-8, Fig. 5-40C, and Fig. 5-41 as guides, check and/or adjust (in listed order) the Type R141A Horizontal Detail Timing.

**NOTE**

The test oscilloscope Intensity control must be advanced to see the complete display as shown in Fig. 5-40C.

**NOTES**

---



---



---



---

TABLE 5-8

Area Affected (see Fig. 5-40C)	Type R141A Adjustment (see Fig. 5-41)		Tolerance
		Adjust for:	
A	R451 (H Sync Start)	2.35 cm	2.25 to 2.45 cm
B	R456 (Equalizer Stop)	1.2 cm	1.23 to 2.12 cm
C	R461 (H Sync Stop)	2.35 cm	2.25 to 2.45 cm
D	R466 (Burst Start)	2.75 cm	2.65 to 2.85 cm
E	R471 (Burst Stop)	1.1 cm	1.0 to 1.2 cm
F	-----	---	5.9 to 6.2 cm
G	-----	---	0.6 to 0.9 cm

q. Test equipment remains connected.

### 33. Check/Adjust Luminance to Chrominance Delay

a. Set the Type R141A COLOUR BAR U, V, Y, and WHITE REF switches up, FULL FIELD COLOUR BAR/MODULATED STAIRCASE switch to COLOUR BAR and the FULL FIELD APL switch to 12.5.

b. Set the test oscilloscope Time Base A Variable (Time/Cm) control to calibrated.

c. Rotate the test oscilloscope Delay-Time Multiplier control so that the green-magenta transition is displayed as shown in Fig. 5-42A.

#### NOTE

The green-magenta transition can be identified in the following manner; starting with sync, rotate the test oscilloscope Delay-Time Multiplier control so that the display moves from left to right across the test oscilloscope graticule. The green-magenta transition is that area of the display between the third and fourth modulation envelopes (colour bars) to the left of sync.

d. Set the test oscilloscope Horizontal Display Sweep Magnifier switch to  $\times 10$ .

e. Set the Type 1A5 Volts/Cm switch to 50 mV and rotate the Variable (Volts/Cm) control and the Position control for a display 5 cm in amplitude, as measured on the test oscilloscope and shown in Fig. 5-42B.

f. CHECK—Test oscilloscope display; green-magenta transition must fall at the 50% (Delay; 20 ns or less) point on the test oscilloscope graticule (see Fig. 5-42B).

g. ADJUST—Luminance to Chrominance Delay control, R418, (see Fig. 5-41) until the green-magenta transition falls at the 50% point on the test oscilloscope graticule.

h. INTERACTION—If this step is performed out of sequence, steps 34, 35, and 36 must also be performed.

i. Test equipment remains connected.

### 34. Check Chrominance Risetime

a. Set the test oscilloscope Horizontal Display Sweep Magnifier switch to Off, Horizontal Display switch to B Intens By 'A' and the Time Base A Time/Cm switch to  $.5 \mu s$ .

b. Set the Type 1A5 Volts/Cm switch to .2 V, Variable (Volts/Cm) control to Cal, and the Position control to center the display on the test oscilloscope.

c. Set the Type R141A COLOUR BAR Y switch down.

d. Rotate the test oscilloscope Delay-Time Multiplier control so that the intensified portion of the display is as shown in Fig. 5-43A.

e. Set the test oscilloscope Horizontal Display switch to A Dly'd, and the Sweep Magnifier switch to  $\times 2$ .

f. Set the Type 1A5 Volts/Cm switch to 20 mV and rotate the Variable (Volts/Cm) control and the Position control for a display 5 cm in amplitude, as measured on the test oscilloscope and shown in Fig. 5-43B.

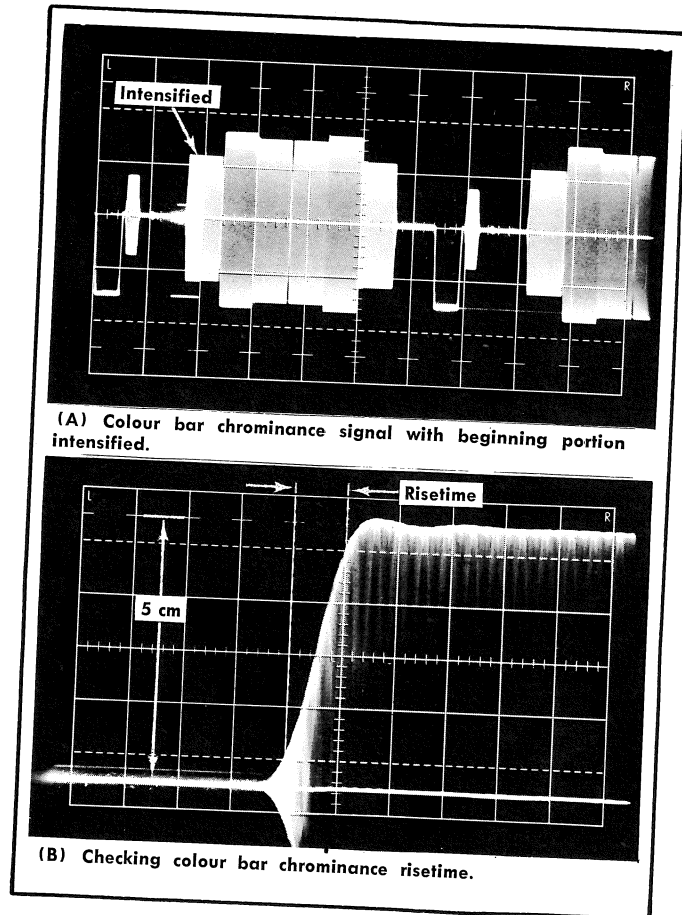

Fig. 5-43. Typical colour bar chrominance displays to check risetime.

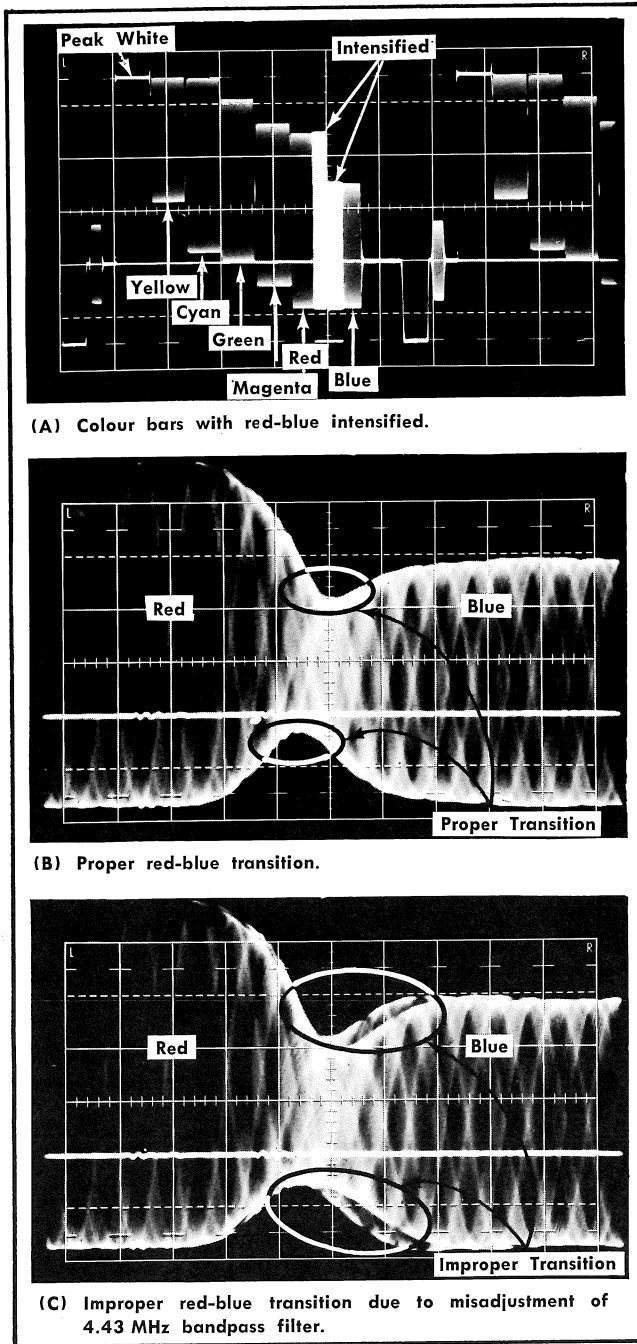

Fig. 5-44. Typical displays to check or adjust 4.43 MHz bandpass filter.

- g. CHECK—Test oscilloscope display; risetime of modulation must be 260 ns within 15%.
- h. Test equipment remains connected.

### 35. Check/Adjust 4.43 MHz Bandpass Filter

- a. Set the Type R141A COLOUR BAR Y switch up.

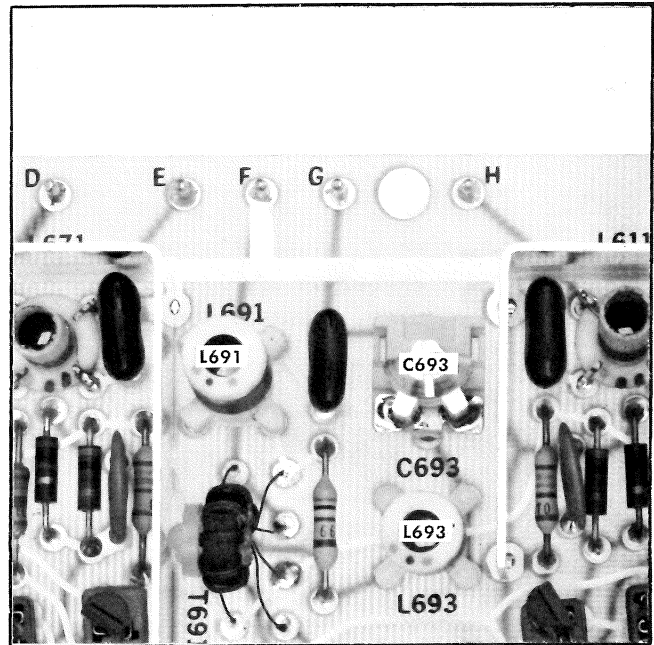

Fig. 5-45. U and V Modulator board adjustment location.

- b. Set the Type 1A5 Volts/Cm switch to .2V, Variable (Volts/Cm) control to Cal, and rotate the Position control to midrange.
- c. Set the test oscilloscope Horizontal Display switch to B Intens By 'A' and the Sweep Magnifier switch to off.
- d. Rotate the test oscilloscope Delay-Time Multiplier control so that the intensified portion of the display is centered on the red and blue colour bars as shown in Fig. 5-44A.
- e. Set the test oscilloscope Horizontal Display switch to A Dly'd and the Sweep Magnifier switch to  $\times 5$ .
- f. Set the Type 1A5 Volts/Cm switch to .1 V and rotate the Position control to center the display.
- g. CHECK—Test oscilloscope display; transition from red to blue must be as shown in Fig. 5-44B.

#### NOTE

Fig. 5-44C shows improper transition from red to blue.

- h. ADJUST—4.43 MHz Bandpass Filter adjustments, C693, L691, and L693, (see Fig. 5-45) for best overlay of the displays as shown in Fig. 5-44B.
- i. Set the test oscilloscope Horizontal Display switch to B Intens By 'A' and the Sweep Magnifier switch to Off.
- j. Set the Type 1A5 Volts/Cm switch to .2 V and rotate the Position control to center the display on the test oscilloscope.
- k. Set the test oscilloscope Delay-Time Multiplier control so that the intensified portion of the display is centered on the green and magenta colour bars.

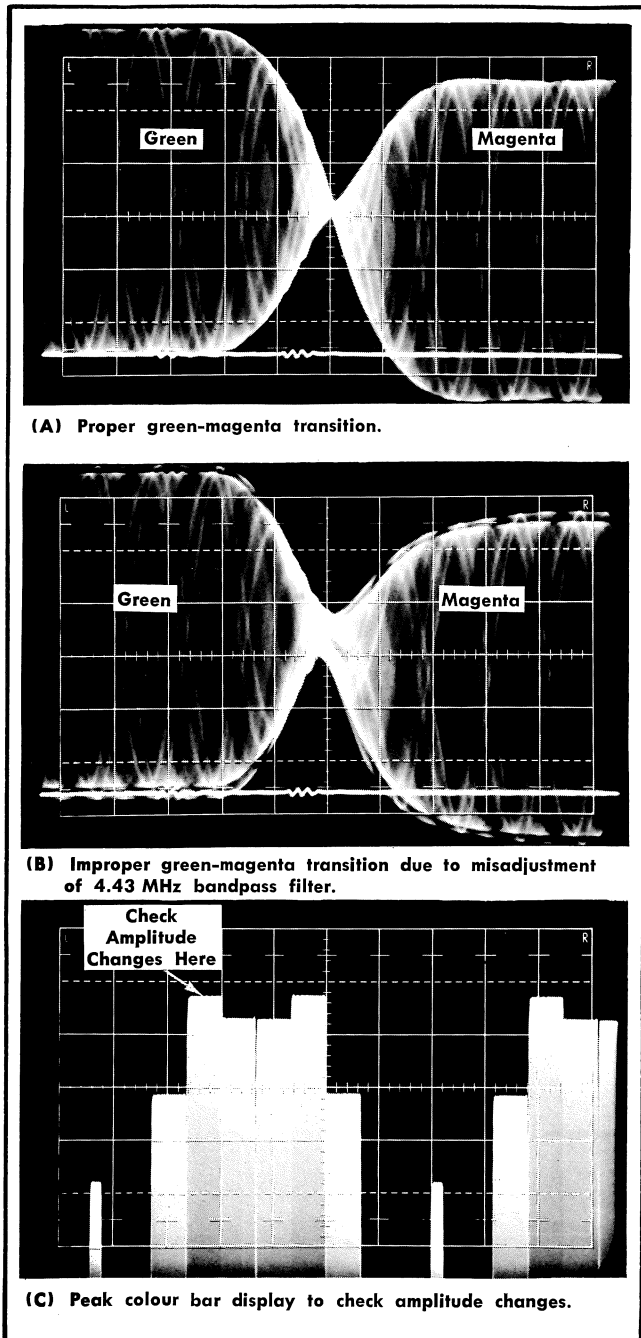

Fig. 5-46. Typical displays to check or adjust 4.43 MHz bandpass filter.

- l. Repeat part e.
- m. Set the Type 1A5 Volts/Cm switch to .1 V and rotate the Position control to position the green-magenta transition to the center graticule line on the test oscilloscope.
- n. CHECK—Test oscilloscope display; transition from green to magenta must be as shown in Fig. 5-46A.

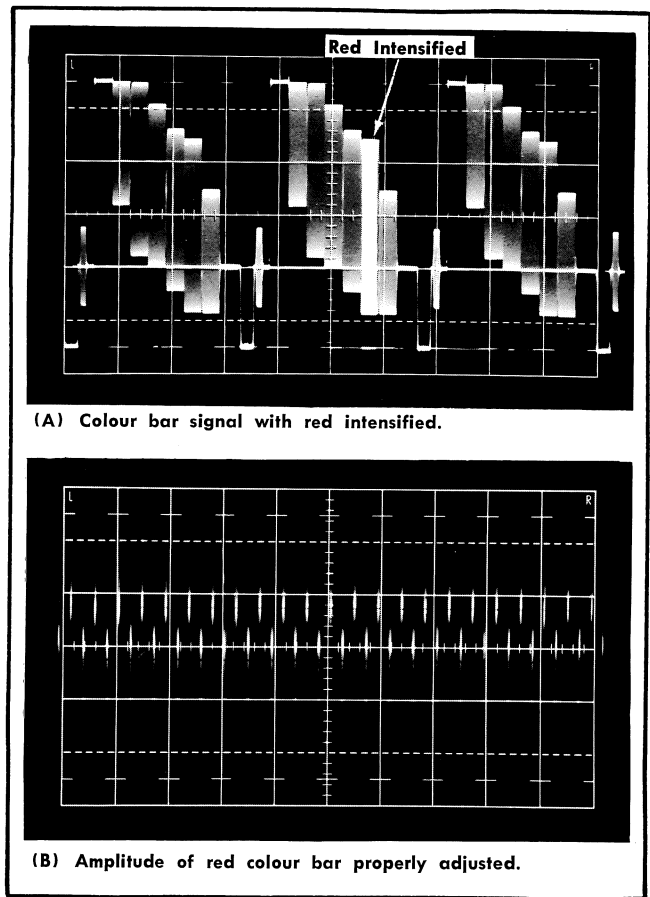

Fig. 5-47. Typical displays used to check or adjust chrominance amplifier gain.

NOTE

Fig. 5-46B shows improper transition from green to magenta.

o. ADJUST—4.43 MHz Bandpass Filter, C693, L691 and L693, (see Fig. 5-45) for best transition from green to magenta as shown in Fig. 5-46A.

- p. Repeat parts i and j.
- q. Set the Type R141A COLOUR BAR Y switch down.
- r. Set the Type 1A5 Volts/Cm switch to 50 mV and rotate the Position control to place the positive portion of the display within the viewing area of the test oscilloscope graticule (see Fig. 5-46C).
- s. Observing the test oscilloscope display, switch the Type R141A V AXIS PHASING switch up and down between 90°/270°, 90°, and 270°, then return the switch to 90°/270°.
- t. CHECK—Test oscilloscope display; amplitude of any colour bar must not change as the Type R141A V AXIS PHASING switch is moved through each position.

u. ADJUST—4.43 MHz Bandpass Filter, C693, L691, and L693, (see Fig. 5-45) until no amplitude change of the colour bars occurs as the Type R141A V AXIS PHASING switch is moved through the different positions.

v. Place the Type R141A V AXIS PHASING switch in the 90°/270° position, then repeat parts a through u until all requirements are met.

**NOTE**

Best overall adjustment of the 4.43 MHz Bandpass Filter will require a compromise between parts h, o, and u.

w. INTERACTION—If the ADJUST portions of this step are performed, Step 36 must also be performed.

x. Test equipment remains connected.

**36. Check/Adjust Chrominance Amplifier Gain**

a. Set the Type R141A COLOUR BAR Y switch up.

b. Set the Type 1A5 Volts/Cm switch to .2 V, Display switch to A-B, and rotate the Position control to center the display on the test oscilloscope.

c. Set the test oscilloscope Time Base B Variable (Time/Cm) control to display three complete lines of video, and the Delay-Time Multiplier control so that the intensified portion of the display centers on the red colour bar as shown in Fig. 5-47A.

d. Set the test oscilloscope Horizontal Display switch to A Dly'd.

e. From the 067-0596-00 calibration fixture Chopped Output connector, connect a 75 ohm coaxial cable to the Type 1A5 B Input connector.

f. Set the Type R141A 25 Hz OFFSET switch down.

g. Set the Type 1A5 B Input AC-GND-DC switch to DC, Volts/Cm switch to 50 mV, and rotate the Position control to position the display as shown in Fig. 5-47B.

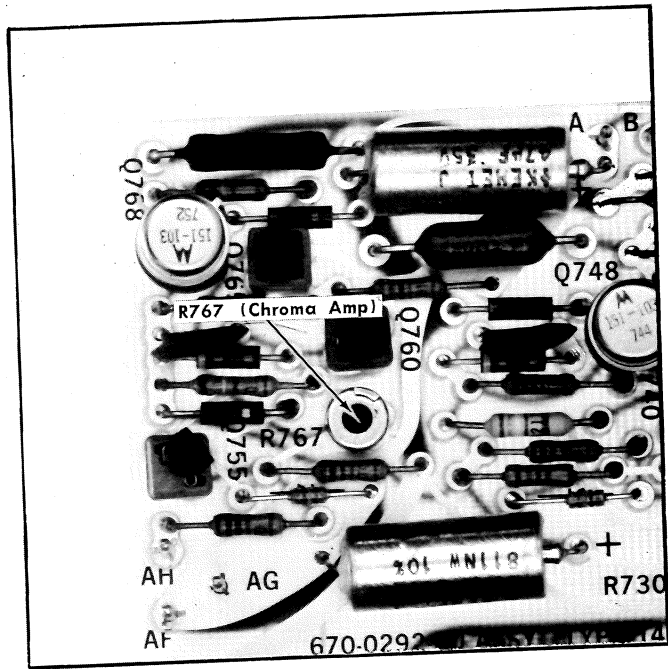

Fig. 5-48. Bar Drive and Video Output board adjustment location.

h. Observing the test oscilloscope display, rotate the 067-0596-00 calibration fixture  $V_2$  Volts control until the top of the bottom display just coincides with the bottom of the top display.

i. CHECK—067-0596-00 calibration fixture  $V_2$  Volts control dial setting; dial setting must be between 3-1-32 and 3-5-32 (663.8 mV,  $\pm 3\%$ ).

j. Set the 067-0596-00 calibration fixture  $V_2$  Volts control for a dial setting of 3-3-32.

k. ADJUST—Chroma Amp control, R767, (see Fig. 5-48) until the top of the bottom display just coincides with the bottom of the top display.

l. Disconnect all test equipment.

**NOTES**

---

---

---

---

---

---

---

---

---

---

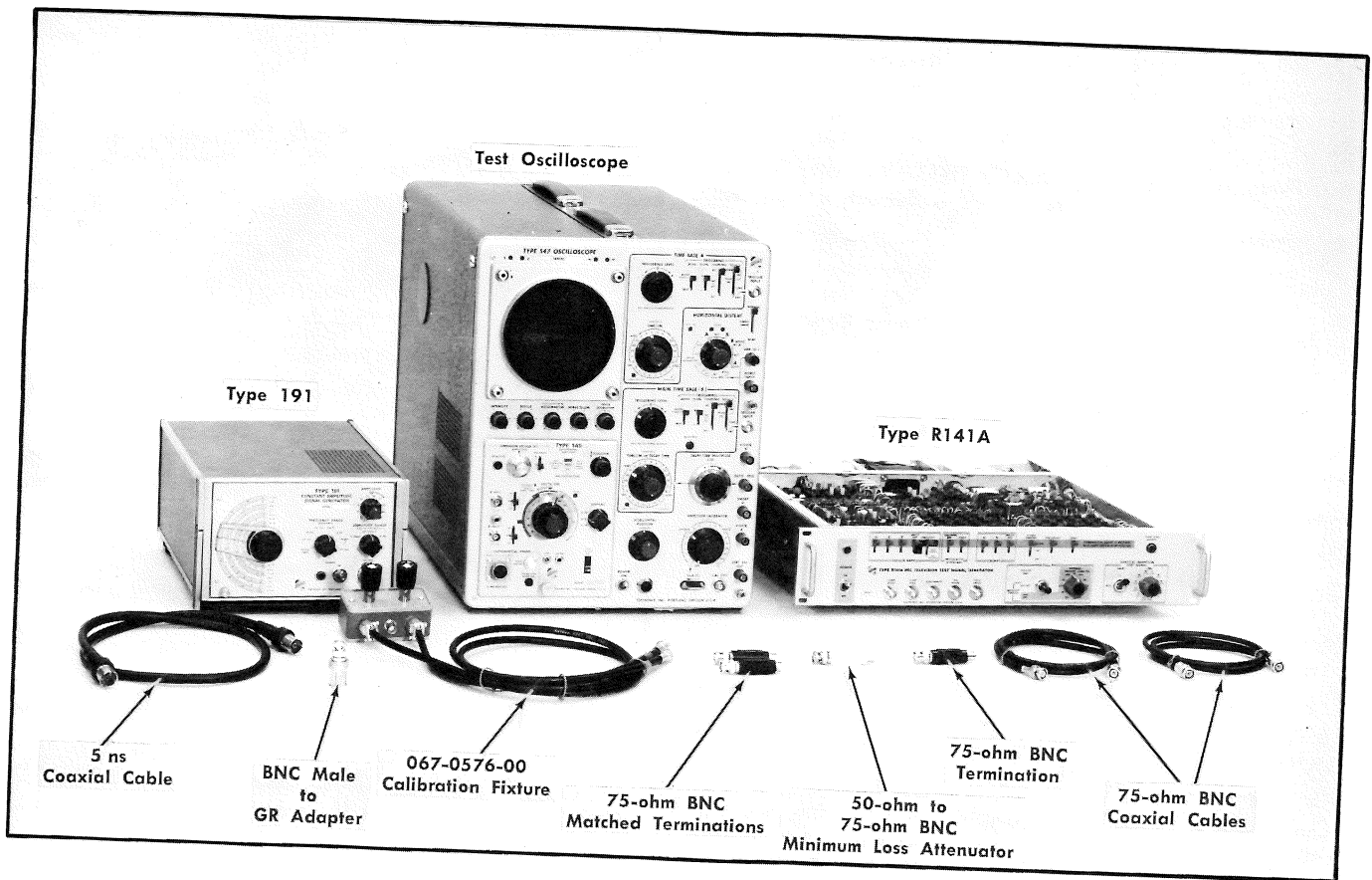

Fig. 5-49. Test equipment required for steps 37 through 39.

**Type R141A Controls**

<b>COLOUR BARS</b>	
U	Up
V	Up
Y	Up
WHITE REF	Up
AMPLITUDE	75%, 0 SETUP
<b>MODULATED STAIRCASE</b>	
<b>SUBCARRIER MOD</b>	<b>Up</b>
<b>STEPS</b>	<b>Up</b>
<b>BURST</b>	
U	Up
V	Up
BRUCH SEQ	Up
V AXIS PHASING	90°/270°
<b>25 Hz OFFSET</b>	<b>Up</b>
SYNC	Up
POWER	On
FULL FIELD	
<b>COLOUR BAR/MODU- LATED STAIRCASE</b>	<b>50% APL</b>

AVERAGE PICTURE LEVEL	12.5
<b>FIELD</b>	<b>1</b>
LINE	11/324

**Test Oscilloscope Controls**

<b>Viewing</b>	
Intensity	As desired
Focus	As desired
Astigmatism	As desired
Scale Illum	As desired
Trace Separation	0
<b>Time Base A</b>	
Triggering Level	CW, pushed in
<b>Triggering</b>	
Mode	Auto
Slope	+
Coupling	AC
Source	Norm
<b>Time/Cm</b>	<b>.2 ms</b>
Variable (Time/Cm)	Calibrated
<b>Time Base B</b>	
Triggering Level	0, pushed in
<b>Triggering</b>	

## Performance Check/Calibration—Type 141A/R141A

Mode	Trig
Slope	—
Coupling	DC
Source	EXT
<b>Time/Cm</b>	<b>10 ms</b>
<b>Variable (Time/Cm)</b>	<b>Calibrated</b>
<b>Horizontal Display</b>	<b>B Intens by 'A'</b>
Sweep Magnifier	Off
Single Sweep	Normal
Delay-Time Multiplier	As is
Horizontal Position	Midrange
Vernier (Horizontal Position)	Midrange
Power	On
Amplitude Calibrator	Off
<b>Type 1A5 Controls</b>	
A Input AC-GND-DC	DC
<b>B Input AC-GND-DC</b>	<b>GND</b>
<b>Volts/Cm</b>	<b>.2 V</b>
Variable (Volts/Cm)	Cal
<b>Display</b>	<b>A-Vc</b>
Position	Midrange
Step Atten Bal	As is
Comparison Voltage	
Amplitude	0-0
Polarity	0
<b>Type 191 Controls</b>	
<b>Frequency</b>	<b>5 MHz</b>
<b>Frequency Range</b>	<b>3.6-8</b>
<b>Power</b>	<b>ON</b>
<b>Amplitude</b>	<b>10</b>
<b>Variable (Amplitude)</b>	<b>Cal</b>
<b>Amplitude Range</b>	<b>.5-5 V</b>

### 37. Check VITS and Bruch Sequence

- Test equipment is shown in Fig. 5-49.
- From the Type R141A COMP VIDEO connector, connect a 75 ohm coaxial cable and a 75 ohm termination to the Type 1A5 A Input connector.
- From the Type R141A rear-panel 12.5 Hz connector, connect a 75-ohm coaxial cable to the test oscilloscope Time Base B Trigger Input connector.
- Rotate the test oscilloscope Delay-Time Multiplier control to move the intensified portion of the display between any two vertical sync pulse intervals.
- Set the test oscilloscope Horizontal Display switch to A Dly'd and the Sweep Magnifier switch to  $\times 5$ .
- CHECK—Test oscilloscope display; there should be one staircase signal for every line of video.

g. Set the Type R141A FULL FIELD COLOUR BAR/MODULATED STAIRCASE switch to VAR APL.

h. CHECK—Test oscilloscope display; there should be one staircase signal every fourth line of video.

i. Set the Type R141A FULL FIELD COLOUR BAR/MODULATED STAIRCASE switch to 50% APL.

j. Set the test oscilloscope Horizontal Display switch to B Intens by 'A' and the Sweep Magnifier switch to Off.

k. Rotate the test oscilloscope Delay-Time Multiplier control to position the intensified portion of the display so that one of the vertical sync intervals is intensified.

l. Set the test oscilloscope Horizontal Display switch to A Dly'd.

m. Using the Field Blanking Details 1 illustration provided on a fold-out page at the rear of the manual, determine the field to which the test oscilloscope has been set; then rotate the test oscilloscope Delay-Time Multiplier control to display the start of field 1.

#### NOTE

Field 1 can be identified by observing the test oscilloscope display just prior to the vertical blanking interval. There will be one-half line of video without burst preceded by a full line of video with burst as shown in the operating displays at the rear of the manual. Field 1 will start with the first vertical serrated sync pulse.

n. Observing the test oscilloscope display, set the Type R141A BURST BRUCH SEQ switch down.

o. CHECK—Test oscilloscope display; one burst must have been added to the half-line of video prior to the vertical sync group and one burst must have been added to the first line following the second group of equalizing pulses. (See Field Blanking Details 1.)

p. Set the Type R141A BURST BRUCH SEQ switch up.

q. CHECK—Test oscilloscope display; VITS signal must be on the eleventh (11th) line of field 1.

r. Observing the test oscilloscope display, switch the Type R141A VITS LINE switch through all settings.

s. CHECK—Test oscilloscope display; VITS signal must be present for all settings of VITS LINE switch and must be on correct line.

t. Set the Type R141A VITS LINE switch to 11/324 and the FIELD switch to 2.

u. CHECK—Test oscilloscope display; VITS signal must not be present on the display as the VITS LINE switch is rotated through all positions (return VITS LINE switch to 11/324).

v. Rotate the test oscilloscope Delay-Time Multiplier so that the display moves from right to left across the test oscilloscope graticule until the next vertical sync group is displayed.

## Performance Check/Calibration—Type 141A/R141A

- w. Repeat part n.
- x. CHECK—Test oscilloscope display; burst must have been added to the last full line preceding the vertical sync group (Field 2).
- y. Repeat part p.
- z. CHECK—Test oscilloscope display; VITS signal must be present on line 324.
- aa. Repeat parts r and s.
- ab. Set the Type R141A VITS LINE switch to 11/324 and the FIELD switch to 1.
- ac. Repeat (in listed order) parts u, v and n.
- ad. CHECK—Test oscilloscope display; burst must have been added to both the half line and the full line preceding the vertical sync group (Field 3).
- ae. Repeat part p.
- af. CHECK—Test oscilloscope display; VITS signal must be present on line 11.
- ag. Repeat parts r and s.
- ah. Set the Type R141A VITS LINE switch to 11/324 and the FIELD switch to 2.
- ai. Repeat part u.
- aj. Rotate the test oscilloscope Delay-Time Multiplier control so that the display moves from left to right across the test oscilloscope graticule until field 4 is displayed.
- ak. Repeat part n.
- al. CHECK—Test oscilloscope display; burst must have been added to line 319 (Field 4).
- am. Repeat part p.
- an. CHECK—Test oscilloscope display; VITS signal must be present on line 324.
- ao. Repeat parts r and s.
- ap. Test equipment remains connected.
- f. CHECK—Test oscilloscope display; signal must be 1 volt peak to peak within 0.2 V.
- g. Disconnect the 75 ohm coaxial cable from the Type R141A rear-panel 1.000 MHz REF FREQ connector and reconnect it to the rear-panel 25 Hz connector.
- h. Set the test oscilloscope Time Base B Time/Cm switch to 10 ms.
- i. CHECK—Test oscilloscope display; signal must be at 0 volts for approximately 20 ms and at 1 volt (within 0.2 V) for approximately 20 ms.
- j. Disconnect the 75 ohm coaxial cable from the Type R141A rear-panel 25 Hz connector and reconnect it to the rear-panel 12.5 Hz connector.
- k. CHECK—Test oscilloscope display; signal must be at 0 volts for approximately 40 ms and at 1 volt (within 0.2 V) for approximately 40 ms.
- l. Disconnect the 75 ohm coaxial cable from the Type R141A rear-panel 12.5 Hz connector and the 75 ohm termination from the Type 1A5 A Input connector.
- m. Test equipment remains connected.

## 39. Check Instrument Return Loss

- a. Set the Type 1A5 A and B Input AC-GND-DC switches to GND.
  - b. Connect the matched 75 ohm terminations to the coaxial cables on the 067-0576-00 calibration fixture, then connect the calibration fixture to the Type 1A5 A and B Input connectors.
  - c. From the Type 191 Constant Amplitude Signal Generator Output connector, in order, connect a 5 ns coaxial cable, BNC Male to GR Adapter, and a 50 ohm to 75 ohm BNC Minimum Loss Attenuator to the Input connector on the 067-0576-00 calibration fixture.
  - d. Set the Type 1A5 A and B Input AC-GND-DC switches to AC, Display switch to A-B and the Volts/Cm switch to .1 V.
  - e. Set the test oscilloscope Time Base B Time/Cm switch to .1 ms, Triggering Level control fully clockwise, Triggering Mode switch to Auto, Triggering Slope switch to + and the Triggering coupling switch to AC.
  - f. Remove the termination from the coaxial cable on the 067-0576-00 calibration fixture marked UNKNOWN.
  - g. Observing the test oscilloscope display, adjust the Type 191 Amplitude and Variable (Amplitude) controls for a display amplitude of 5 cm (.5 V).
  - h. Replace the termination disconnected in part f.
  - i. Set the Type 1A5 Volts/Cm switch to 1 mV.
  - j. CHECK—Test oscilloscope display; amplitude of display must be no more than 1 mV peak to peak.
  - k. Set the Type 1A5 Volts/Cm switch to 5 mV.
  - l. Repeat part f.
- ## 38. Check Other Signal Outputs
- a. Set the Type R141A VITS LINE switch to 11/324, FIELD switch to BOTH and the FULL FIELD COLOUR BAR/MODULATED STAIRCASE switch to COLOUR BAR.
  - b. Set the Type 1A5 Volts/Cm switch to .5 V.
  - c. Set the test oscilloscope Horizontal Display switch to B, Time/Cm switch to  $.2 \mu\text{s}$  and the Triggering Source switch to Int.
  - d. Disconnect the 75 ohm coaxial cable from the Type R141A COMP VIDEO connector and reconnect it to the rear-panel 1.000 MHz REF FREQ connector.
  - e. Rotate the test oscilloscope Time Base B Triggering Level control for a triggered display.



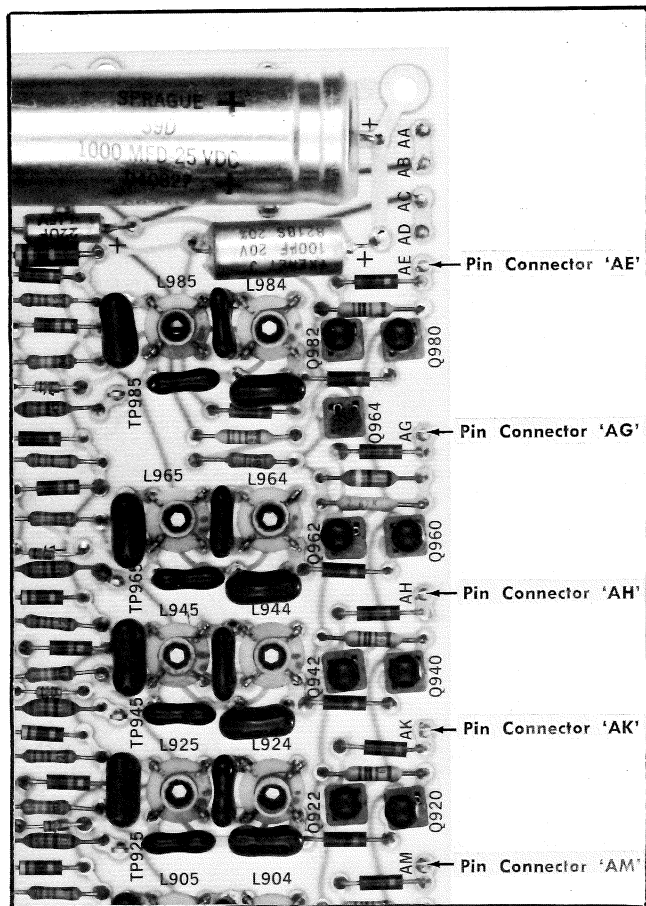

Fig. 5-50. Output Amplifier board pin connector locations.

**NOTE**

Throughout the Performance Check/Calibration procedure, if only a Performance Check is being performed, the Type R141A top and bottom covers are not removed. (Exception; see Steps 6 and 21.) To check Instrument Return Loss, both top and bottom covers must be removed. Remove the covers, perform the step, then replace the covers.

- m. Set the Type R141A POWER switch OFF.
- n. Disconnect pin connectors "AE", "AG", "AH", "AK", and "AM" on the Type R141A Output Amplifier board, see Fig. 5-50.
- o. Remove Q556 (see Fig. 5-51) from the Type R141A Staircase board.

**CAUTION**

Place the disconnected leads so that no contact will occur between the metal pin connectors and the chassis.

- p. Set the Type 1A5 POWER switch ON.
- q. Connect the unterminated coaxial cable (UNKNOWN) to the Type R141A COMP SYNC connector.

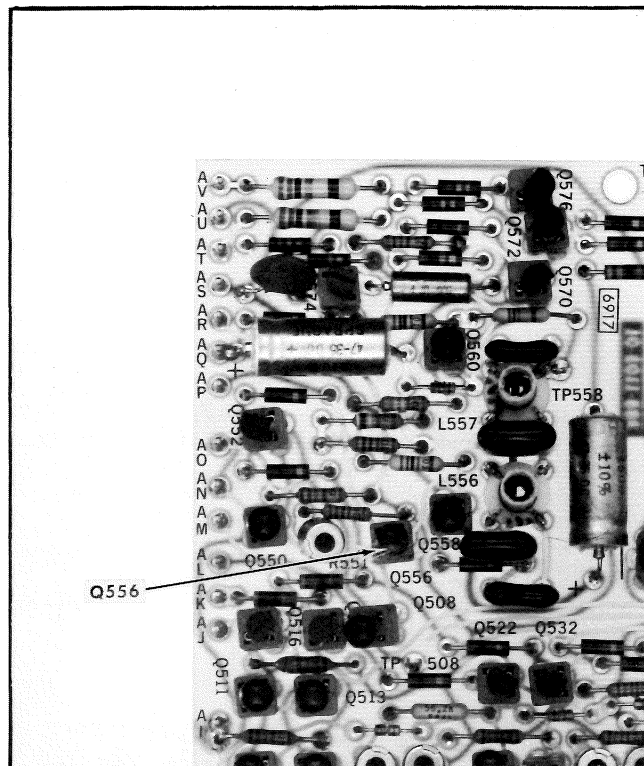

Fig. 5-51. Staircase board component location.

r. CHECK—Test oscilloscope display; display amplitude must be no more than 15 mV peak to peak (30 dB).

s. Repeat part q and r for the following Type R141A Output connectors: PAL PULSE, FIELD DRIVE, rear-panel COMP SYNC, rear-panel PAL PULSE, rear-panel FIELD DRIVE, rear-panel BURST FLAG, rear-panel LINE DRIVE, and the rear-panel COMP BLANKING connectors.

t. Set the Type R141A POWER switch OFF.

u. Disconnect the 75 ohm coaxial cable from the Type R141A rear-panel COMP BLANKING connector.

v. Connect all pin connectors removed in part n and replace Q556 remove in part o.

w. Replace the Type R141A top and bottom covers.

x. Set the Type R141A POWER switch ON.

y. Set the Type R141A COLOUR BAR U, V, and Y switches down and the SYNC switch down.

z. Connect the 75 ohm coaxial cable disconnected in part u to the rear-panel COMP VIDEO connector.

aa. Repeat part r. (Disregard switching transients.)

ab. Disconnect the 75 ohm coaxial cable from the Type R141A rear-panel COMP VIDEO connector and reconnect it to the COMP VIDEO Connector.

ac. Repeat part r.

ad. Disconnect all test equipment and connections.

Performance Check/Calibration—Type 141A/R141A

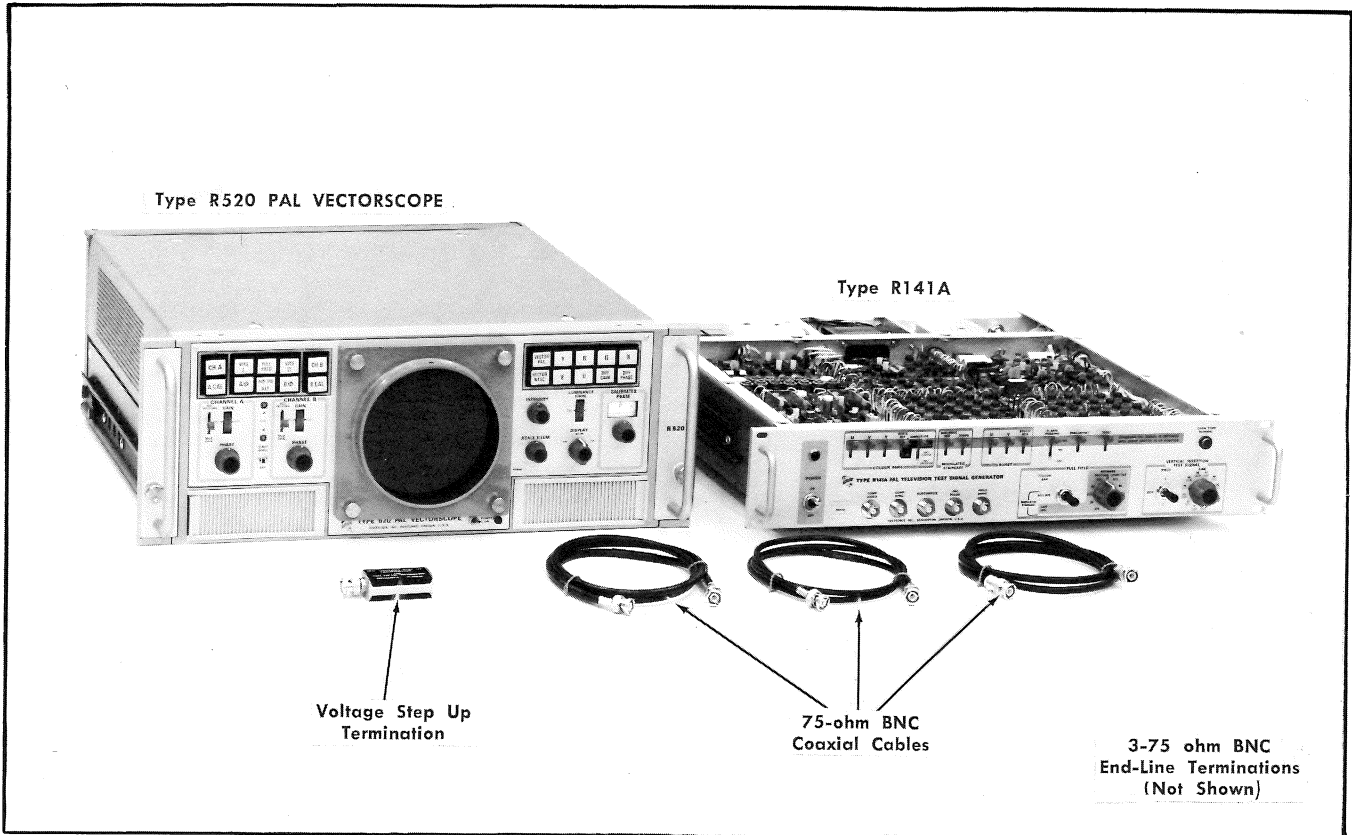

Fig. 5-52. Test equipment required for steps 40 and 41.

**Type R141A Controls**

COLOUR BARS

<b>U</b>	<b>Up</b>
<b>V</b>	<b>Up</b>
<b>Y</b>	<b>Up</b>
WHITE REF	Up
AMPLITUDE	Up
MODULATED STAIRCASE	
SUBCARRIER MOD	Up
STEPS	Up
BURST	
U	Up
V	Up
BURCH SEQ	Up
V AXIS PHASING	90°/270°
25 Hz OFFSET	Up
<b>SYNC</b>	<b>Up</b>
POWER	On
FULL FIELD	
<b>COLOUR BAR/MODULATED STAIRCASE</b>	<b>VAR APL</b>
AVERAGE PICTURE LEVEL	12.5

VERTICAL INSERTION TEST SIGNAL

FIELD	BOTH
LINE	11/324

**Type R520 PAL Vectorscope Controls**

Signal Selector	CH A, A $\phi$ , FULL FIELD
Channel A	
<b>100% -75% -Max Gain</b>	<b>100%</b>
Gain	Cal
Phase	As is
A Cal	As is
B Cal	As is
$\phi$ Ref	<b>Ext</b>
Channel B	Not used
Function Selector	Vector PAL
Intensity	As desired
Luminance Gain	Cal
Scale Illum	As desired
Display	Both
Calibrated Phase	0
Power	On
Quad Phase	As is

Gain Bal	As is
Horiz Position Clamp	As is
Beam Rotate	As is
Vert Position Clamp	As is
Focus	As is
Field	1
Vert Position	As is
Burst Flag Timing	As is
<b>Sync</b>	<b>Ext</b>
Horiz Position	As is

#### 40. Check Diff Gain and Diff Phase

a. Test equipment is shown in Fig. 5-52.

b. From the Type R520 PAL Channel A J1 connector, connect the 011-0109-00 Voltage Step Up Termination and a 75 ohm coaxial cable to the Type R141A COMP VIDEO connector.

#### NOTE

Do not terminate the Type R520 PAL Channel A J2 connector.

c. From the Type R520 PAL EXT SYNC J120 connector, connect a 75 ohm coaxial cable to the Type R141A COMP SYNC connector.

d. Connect a 75 ohm end-line termination to the Type R520 PAL EXT SYNC J121 connector.

e. From the Type R520 PAL EXT CW  $\phi$  REF J311 connector, connect a 75 ohm coaxial cable to the Type R141A SUB-CARRIER connector.

f. Connect a 75 ohm end-line termination to the Type R520 PAL EXT CW  $\phi$  REF J310 connector.

g. Observing the Type R520 PAL display, rotate the Channel A Gain control until the two burst vectors and the short vector are within the compass rose of the vector graticule.

h. Rotate the Type R520 PAL A Phase control to align the short vector with the 0°/180° axis of the vector graticule as shown in Fig. 5-53A.

i. Rotate the Type R520 PAL Channel A Gain control until the short vector lies on the inscribed compass rose as shown in Fig. 5-53B.

j. Check that the burst vectors and the short vector start from the center of the vector graticule. If they do not, adjust the Type R520 PAL Horizontal and Vertical Position Clamp controls until the vectors start from the center of the vector graticule, then repeat parts h and i.

k. Press the Type R520 PAL Function Selector Diff Gain pushbutton.

l. Rotate the Type R520 PAL Vertical Position control to position the display as shown in Fig. 5-53C.

m. CHECK—Type R520 PAL display; Diff Gain must be less than 0.5% as measured on the Diff Gain Scale.

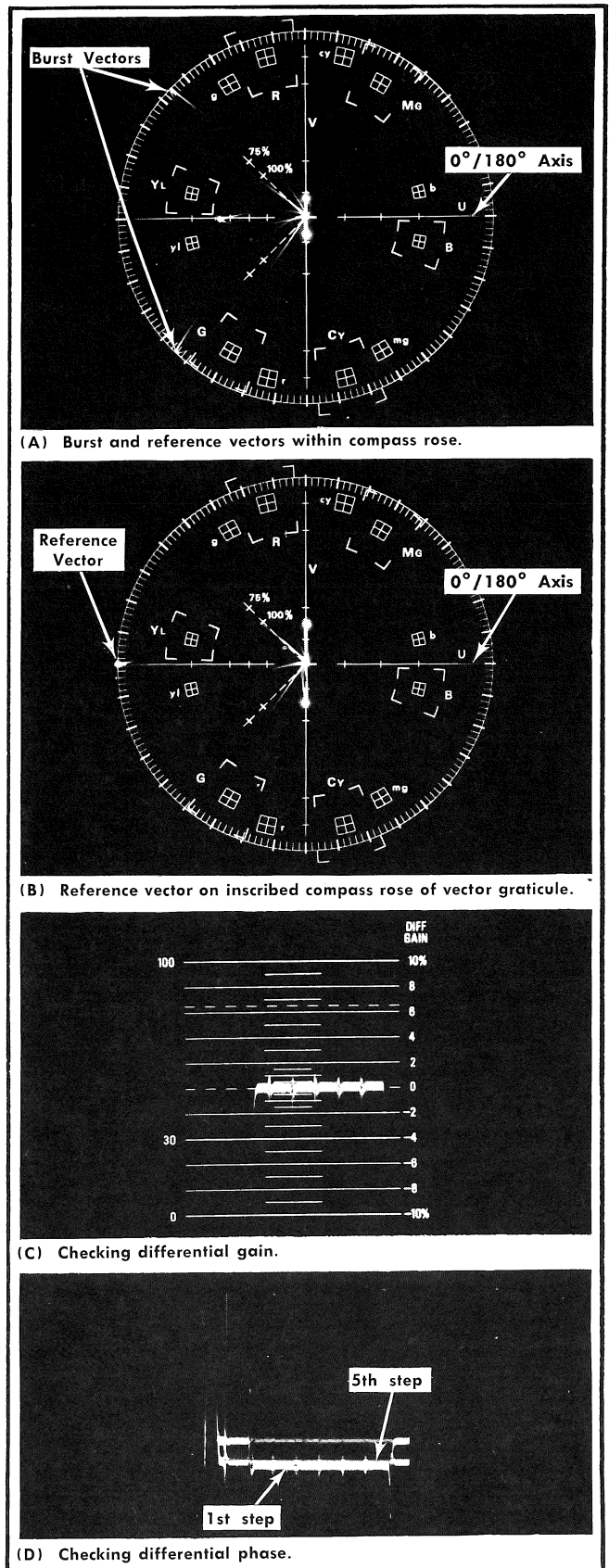

Fig. 5-53. Typical Type R520 PAL displays to check differential gain and differential phase.

## Performance Check/Calibration—Type 141A/R141A

- n. Set the Type R141A FULL FIELD APL switch to 50.
- o. Repeat part m.
- p. Set the Type R141A FULL FIELD APL switch to 87.5.
- q. Repeat part m.
- r. Press the Type R520 PAL Function Selector Diff Phase pushbutton.
- s. Check that the Type R520 PAL Calibrated Phase Dial is set to 0.
- t. Rotate the Type R520 A Phase control to center the display and then use the same control as a coarse adjustment to null the first step on the display as shown in Fig. 5-53D.
- u. Rotate the Type R520 PAL Calibrated Phase control to again null the first step.

### NOTE

The calibrated Phase control is used as a vernier adjustment.

- v. Note and record the Type R520 PAL Calibrated Phase control dial setting.
- w. Rotate the Type R520 PAL Calibrated Phase control to null the fifth step.
- x. Note and record the Type R520 PAL Calibrated Phase control dial setting.
- y. Subtract the dial reading obtained in parts v and x.
- z. CHECK—Diff Phase; resultant noted in part y must be less than  $0.1^\circ$ .
- aa. Set the Type R141A FULL FIELD APL switch to 50.
- ab. Repeat parts s through z.
- ac. Set the Type R141A FULL FIELD APL switch to 12.5.
- ad. Repeat part ab.
- ae. Test equipment remains connected.

## 41. Check V Axis Phasing

- a. Disconnect the 011-0109-00 Voltage Step Up Termination from the Type R520 PAL Channel A J1 and the 75 ohm coaxial cable; connect the 75 ohm coaxial cable to the Type 520 PAL Channel A J1 connector.
- b. Connect a 75 ohm end-line termination to the Type R520 PAL Channel A J2 connector.
- c. Set the Type R141A FULL FIELD COLOUR BAR/MODULATED STAIRCASE switch to COLOUR BAR.
- d. Press the Type R520 PAL Function Selector Vector PAL pushbutton, set the Channel A 100%-75%-Max Gain switch to 75%, and rotate the Channel A Gain control to Cal.
- e. Rotate the Type R520 PAL A Phase control to align the short vector with the  $0^\circ/180^\circ$  axis of the vector graticule.

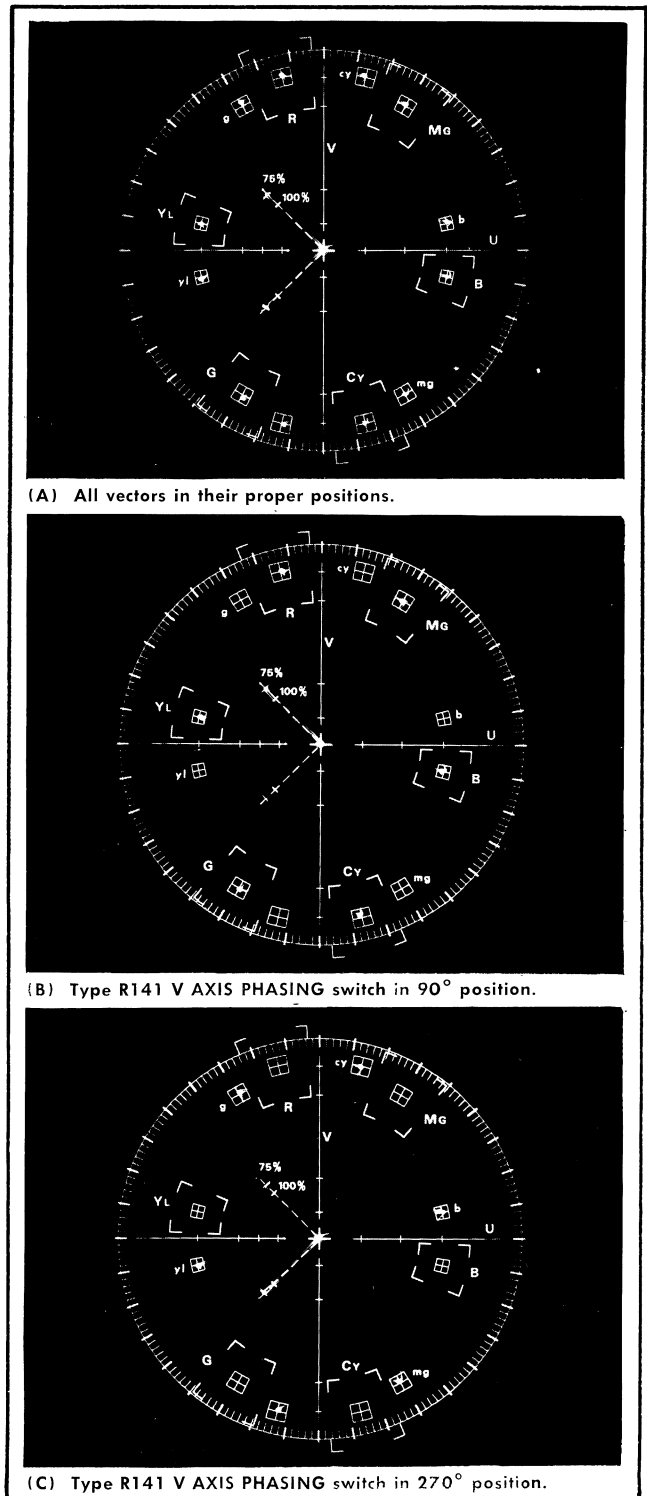

Fig. 5-54. Typical Type R520 PAL displays to check V axis phasing.

- f. CHECK—Type R520 PAL display; all burst and colour vectors must be in their correct positions with regard to the vector graticule as shown in Fig. 5-54A.

### Performance Check/Calibration—Type 141A/R141A

- g. Set the Type R141A V AXIS PHASING switch to  $90^\circ$ .
- h. If necessary, rotate the Type R520 PAL A Phase control to align the short vector with the  $0^\circ/180^\circ$  axis on the vector graticule.
- i. CHECK—Type R520 PAL display; position of burst and colour vectors must be as shown in Fig. 5-54B.
- j. Set the Type R141A V AXIS PHASING switch to  $270^\circ$ .
- k. Repeat part h.

l. CHECK—Type R520 PAL display; position of burst and colour vectors must be as shown in Fig. 5-54C.

m. Set the Type R141A V AXIS PHASING switch to  $90^\circ/270^\circ$ .

n. Disconnect all test equipment and connections.

This completes the Performance Check and/or Calibration procedure. Replace top and bottom covers (Calibration Procedure only).



## PARTS LIST ABBREVIATIONS

BHB	binding head brass	int	internal
BHS	binding head steel	lg	length or long
cap.	capacitor	met.	metal
cer	ceramic	mtg hdw	mounting hardware
comp	composition	OD	outside diameter
conn	connector	OHB	oval head brass
CRT	cathode-ray tube	OHS	oval head steel
csk	countersunk	P/O	part of
DE	double end	PHB	pan head brass
dia	diameter	PHS	pan head steel
div	division	plstc	plastic
elect.	electrolytic	PMC	paper, metal cased
EMC	electrolytic, metal cased	poly	polystyrene
EMT	electrolytic, metal tubular	prec	precision
ext	external	PT	paper, tubular
F & I	focus and intensity	PTM	paper or plastic, tubular, molded
FHB	flat head brass	RHB	round head brass
FHS	flat head steel	RHS	round head steel
Fil HB	fillister head brass	SE	single end
Fil HS	fillister head steel	SN or S/N	serial number
h	height or high	S or SW	switch
hex.	hexagonal	TC	temperature compensated
HHB	hex head brass	THB	truss head brass
HHS	hex head steel	thk	thick
HSB	hex socket brass	THS	truss head steel
HSS	hex socket steel	tub.	tubular
ID	inside diameter	var	variable
inc	incandescent	w	wide or width
		WW	wire-wound

## **PARTS ORDERING INFORMATION**

Replacement parts are available from or through your local Tektronix, Inc. Field Office or representative.

Changes to Tektronix instruments are sometimes made to accommodate improved components as they become available, and to give you the benefit of the latest circuit improvements developed in our engineering department. It is therefore important, when ordering parts, to include the following information in your order: Part number, instrument type or number, serial or model number, and modification number if applicable.

If a part you have ordered has been replaced with a new or improved part, your local Tektronix, Inc. Field Office or representative will contact you concerning any change in part number.

## **SPECIAL NOTES AND SYMBOLS**

- |                 |   |
|-----------------|---|
| ×000            | Part first added at this serial number  |
| 00×             | Part removed after this serial number   |
| *000-0000-00    | Asterisk preceding Tektronix Part Number indicates manufactured by or for Tektronix, Inc., or reworked or checked components. |
| Use 000-0000-00 | Part number indicated is direct replacement.  |



# SECTION 6

## ELECTRICAL PARTS LIST

Values are fixed unless marked Variable.

Ckt. No.	Tektronix Part No.	Serial/Model No. Eff	Disc	Description			
<b>Bulbs</b>							
DS42	150-0018-00			Incandescent, miniature 6.3 V			
DS68	150-0065-00	B010100	B119999	Incandescent, 10 V, 40 mA green lens			
DS68	150-0089-00	B120000		Incandescent, 0.4 W, 80 mA yellow lens			
<b>Capacitors</b>							
Tolerance $\pm 20\%$ unless otherwise indicated.							
C11	290-0300-00	B010100	B039999	1300 $\mu\text{F}$	Elect.	40 V	+75%—10%
C11	290-0334-00	B040000		1250 $\mu\text{F}$	Elect.	50 V	+75%—10%
C42	290-0321-00			11000 $\mu\text{F}$	Elect.	15 V	+100%—10%
C61	290-0086-00			2000 $\mu\text{F}$	Elect.	30 V	
C105	281-0122-00	B010100	B049999	2.5-9 pF, Var	Cer		
C105	281-0152-00	B050000		0.8-10 pF, Var	Air		
C106	283-0637-00			20 pF	Mica	100 V	1%
C107	283-0594-00			0.001 $\mu\text{F}$	Mica	100 V	1%
C108	283-0004-00			0.02 $\mu\text{F}$	Cer	150 V	
C113	283-0067-00			0.001 $\mu\text{F}$	Cer	200 V	10%
C117	283-0567-00			360 pF	Mica	500 V	1%
C118	283-0633-00			77 pF	(nominal value)	Selected	
C119	283-0004-00			0.02 $\mu\text{F}$	Cer	150 V	
C122	283-0637-00			20 pF	Mica	100 V	1%
C125	283-0080-00			0.022 $\mu\text{F}$	Cer	25 V	+80%—20%
C126	283-0080-00			0.022 $\mu\text{F}$	Cer	25 V	+80%—20%
C128	283-0003-00			0.01 $\mu\text{F}$	Cer	150 V	
C130	283-0641-00			180 pF	Mica	100 V	1%
C131	283-0026-00			0.2 $\mu\text{F}$	Cer	25 V	
C132	281-0125-00			90-400 pF, Var	Mica		
C137	283-0026-00			0.2 $\mu\text{F}$	Cer	25 V	
C139	283-0026-00			0.2 $\mu\text{F}$	Cer	25 V	
C152	283-0177-00			1 $\mu\text{F}$	Cer	25 V	+80%—20%
C229	283-0032-00			470 pF	Cer	500 V	5%
C246	283-0032-00			470 pF	Cer	500 V	5%
C247	283-0032-00			470 pF	Cer	500 V	5%
C258	283-0032-00			470 pF	Cer	500 V	5%
C260	283-0051-00	XB130000		0.0033 $\mu\text{F}$	Cer	100 V	5%
C261	283-0065-00	XB130000		0.001 $\mu\text{F}$	Cer	100 V	5%
C309	283-0555-00			2000 pF	Mica	500 V	1%
C310	283-0555-00			2000 pF	Mica	500 V	1%
C311	285-0595-00			0.1 $\mu\text{F}$	PMT	100 V	1%
C313	285-0595-00			0.1 $\mu\text{F}$	PMT	100 V	1%
C317	290-0134-00			22 $\mu\text{F}$	Elect.	15 V	
C318	290-0134-00			22 $\mu\text{F}$	Elect.	15 V	

Electrical Parts List—Type 141A/R141A

Capacitors (cont)

Ckt. No.	Tektronix Part No.	Serial/Model No. Eff	Disc	Description		
C319	290-0284-00		4.7 $\mu$ F	Elect.	35 V	10%
C323	285-0595-00		0.1 $\mu$ F	PTM	100 V	1%
C324	290-0284-00		4.7 $\mu$ F	Elect.	35 V	10%
C325	283-0003-00		0.01 $\mu$ F	Cer	150 V	
C327	283-0003-00		0.01 $\mu$ F	Cer	150 V	
C330	283-0003-00		0.01 $\mu$ F	Cer	150 V	
C332	283-0003-00		0.01 $\mu$ F	Cer	150 V	
C337	283-0552-00		200 pF	Mica	500 V	1%
C338	283-0004-00		0.02 $\mu$ F	Cer	150 V	
C339	283-0004-00		0.02 $\mu$ F	Cer	150 V	
C340	283-0004-00		0.02 $\mu$ F	Cer	150 V	
C341	283-0004-00		0.02 $\mu$ F	Cer	150 V	
C345	283-0026-00		0.2 $\mu$ F	Cer	25 V	
C346	283-0004-00		0.02 $\mu$ F	Cer	150 V	
C347	283-0552-00		200 pF	Mica	500 V	1%
C351	283-0026-00		0.2 $\mu$ F	Cer	25 V	
C352	283-0004-00		0.02 $\mu$ F	Cer	150 V	
C353	283-0598-00		253 pF	Mica	300 V	5%
C354	283-0598-00		253 pF	Mica	300 V	5%
C355	283-0004-00		0.02 $\mu$ F	Cer	150 V	
C356	283-0010-00		0.05 $\mu$ F	Cer	50 V	
C357	283-0594-00		0.001 $\mu$ F	Mica	100 V	1%
C358	283-0555-00		2000 pF	Mica	500 V	1%
C359	283-0555-00		2000 pF	Mica	500 V	1%
C360	283-0060-00		100 pF	Cer	200 V	5%
C361	283-0150-00		650 pF	Cer	200 V	5%
C364	290-0134-00		22 $\mu$ F	Elect.	15 V	
C370	290-0246-00		3.3 $\mu$ F	Elect.	15 V	10%
C371	283-0059-00	B010100	1 $\mu$ F	Cer	25 V	+80%—20%
C371	285-0809-00	B120000	1 $\mu$ F	PTM	50 V	10%
C375	290-0134-00		22 $\mu$ F	Elect.	15 V	
C377	290-0246-00		3.3 $\mu$ F	Elect.	15 V	10%
C378	290-0246-00		3.3 $\mu$ F	Elect.	15 V	10%
C381	281-0550-00		120 pF	Cer	500 V	10%
C385	283-0026-00		0.2 $\mu$ F	Cer	25 V	
C386	283-0622-00		450 pF	Mica	300 V	1%
C387	283-0032-00		470 pF	Cer	500 V	5%
C389	283-0032-00		470 pF	Cer	500 V	5%
C394	283-0032-00		470 pF	Cer	500 V	5%
C395	283-0617-00		4700 pF	Mica	300 V	10%
C397	283-0032-00		470 pF	Cer	500 V	5%
C401	283-0032-00		470 pF	Cer	500 V	5%
C403	290-0114-00		47 $\mu$ F	Elect.	6 V	
C404	283-0641-00		180 pF	Mica	100 V	1%
C409	283-0026-00		0.2 $\mu$ F	Cer	25 V	
C413	283-0026-00		0.2 $\mu$ F	Cer	25 V	

## Capacitors (cont)

Ckt. No.	Tektronix Part No.	Serial/Model No. Eff	Disc	Description		
C418	283-0598-00			253 pF	Mica	300 V 5%
C420	283-0047-00			270 pF	Cer	500 V 5%
C425	283-0594-00			0.001 $\mu$ F	Mica	100 V 1%
C430	283-0032-00			470 pF	Cer	500 V 5%
C434	283-0032-00			470 pF	Cer	500 V 5%
C440	283-0594-00			0.001 $\mu$ F	Mica	100 V 1%
C443	283-0004-00			0.02 $\mu$ F	Cer	150 V
C444	283-0149-00			25 pF	Cer	200 V 2%
C445	283-0004-00			0.02 $\mu$ F	Cer	150 V
C451	283-0077-00			330 pF	Cer	500 V 5%
C456	283-0077-00			330 pF	Cer	500 V 5%
C461	283-0077-00			330 pF	Cer	500 V 5%
C466	283-0077-00			330 pF	Cer	500 V 5%
C471	283-0077-00			330 pF	Cer	500 V 5%
C476	283-0032-00			470 pF	Cer	500 V 5%
C485	283-0032-00			470 pF	Cer	500 V 5%
C491	283-0077-00			330 pF	Cer	500 V 5%
C496	283-0032-00			470 pF	Cer	500 V 5%
C508	283-0004-00	XB090000		0.02 $\mu$ F	Cer	150 V
C519	283-0032-00			470 pF	Cer	500 V 5%
C555	283-0594-00			0.001 $\mu$ F	Mica	100 V 1%
C556	283-0634-00			65 pF	Mica	100 V 1%
C557	283-0622-00			450 pF	Mica	300 V 1%
C558	283-0640-00		160 pF	Mica	100 V 1%	
C561	290-0312-00			47 $\mu$ F	Elect.	35 V 10%
C571	290-0312-00			47 $\mu$ F	Elect.	35 V 10%
C572	283-0004-00			0.02 $\mu$ F	Cer	150 V
C574	290-0312-00			47 $\mu$ F	Elect.	35 V 10%
C577	290-0415-00			5.6 $\mu$ F	Elect.	35 V
C582	283-0026-00			0.2 $\mu$ F	Cer	25 V
C591	283-0004-00			0.02 $\mu$ F	Cer	150 V
C611	283-0628-00			410 pF	Mica	500 V 1%
C612	283-0632-00			87 pF	Mica	100 V 1%
C616	283-0004-00			0.02 $\mu$ F	Cer	150 V
C621	283-0628-00			410 pF	Mica	500 V 1%
C622	283-0632-00			87 pF	Mica	100 V 1%
C628	281-0116-00			1.6-9.1 pF, Var	Air	
C645	281-0116-00			1.6-9.1 pF, Var	Air	
C646	283-0552-00			200 pF	Mica	500 V 1%
C647	283-0552-00			200 pF	Mica	500 V 1%
C648	283-0004-00			0.02 $\mu$ F	Cer	150 V
C661	283-0628-00	B010100 B030000	B029999	410 pF	Mica	500 V 1%
C661	283-0669-00			360 pF	Mica	500 V 1%
C662	283-0632-00			87 pF	Mica	100 V 1%
C666	283-0004-00			0.02 $\mu$ F	Cer	150 V
C671	283-0628-00			410 pF	Mica	500 V 1%
C672	283-0632-00			87 pF	Mica	100 V 1%
C678	281-0116-00			1.6-9.1 pF, Var	Air	

Electrical Parts List—Type 141A/R141A

Capacitors (cont)

Kct. No.	Tektronix Part No.	Serial/Model No. Eff	No. Disc	Description			
C691	283-0616-00			75 pF	Mica	500 V	5%
C693	281-0081-00			1.8-13 pF, Var	Air		
C694	290-0312-00			47 $\mu$ F	Elect.	35 V	10%
C696	290-0183-00			1 $\mu$ F	Elect.	35 V	10%
C698	290-0312-00			47 $\mu$ F	Elect.	35 V	10%
C707	283-0051-00			0.0033 $\mu$ F	Cer	100 V	5%
C714	283-0622-00			450 pF	Mica	300 V	1%
C715	283-0149-00			25 pF	Cer	200 V	2%
C716	283-0640-00			160 pF	Mica	100 V	1%
C717	283-0634-00			65 pF	Mica	100 V	1%
C720	290-0312-00			47 pF	Elect.	35 V	10%
C724	283-0594-00			0.001 $\mu$ F	Mica	100 V	1%
C725	283-0634-00			65 pF	Mica	100 V	1%
C726	283-0622-00			450 pF	Mica	300 V	1%
C727	283-0640-00			160 pF	Mica	100 V	1%
C740	283-0003-00			0.01 $\mu$ F	Cer	150 V	
C752	283-0004-00	XB040000		0.02 $\mu$ F	Cer	150 V	
C760	283-0003-00			0.01 $\mu$ F	Cer	150 V	
C770	281-0022-00			8-50 pF, Var	Cer		
C787	281-0022-00			8-50 pF, Var	Cer		
C796	283-0004-00			0.02 $\mu$ F	Cer	150 V	
C798	283-0059-00			1 $\mu$ F	Cer	25 V	+80%—20%
C799	290-0312-00			47 pF	Elect.	35 V	10%
C835	290-0162-00			22 $\mu$ F	Elect.	35 V	
C850	283-0002-00			0.01 $\mu$ F	Cer	500 V	
C855	290-0171-00			100 $\mu$ F	Elect.	12 V	
C871	283-0026-00			0.2 $\mu$ F	Cer	25 V	
C875	283-0000-00			0.001 $\mu$ F	Cer	500 V	
C880	283-0010-00			0.05 $\mu$ F	Cer	50 V	
C885	290-0312-00			47 $\mu$ F	Elect.	35 V	10%
C903	283-0594-00			0.001 $\mu$ F	Mica	100 V	1%
C904	283-0634-00			65 pF	Mica	100 V	1%
C905	283-0640-00			160 pF	Mica	100 V	1%
C906	283-0622-00			450 pF	Mica	300 V	1%
C912	283-0004-00			0.02 $\mu$ F	Cer	150 V	
C914	290-0415-00			5.6 $\mu$ F	Elect.	35 V	10%
C916	283-0004-00			0.02 $\mu$ F	Cer	150 V	
C923	283-0594-00			0.001 $\mu$ F	Mica	100 V	1%
C924	283-0634-00			65 pF	Mica	100 V	1%
C925	283-0640-00			160 pF	Mica	100 V	1%
C926	283-0622-00			450 pF	Mica	300 V	1%
C932	283-0004-00			0.02 $\mu$ F	Cer	150 V	
C934	290-0415-00			5.6 $\mu$ F	Elect.	35 V	10%
C936	283-0004-00			0.02 $\mu$ F	Cer	150 V	
C943	283-0594-00			0.001 $\mu$ F	Mica	100 V	1%

Capacitors (cont)

Ckt. No.	Tektronix Part No.	Serial/Model No.		Description			
		Eff	Disc				
C944	283-0634-00			65 pF	Mica	100 V	1%
C945	283-0640-00			160 pF	Mica	100 V	1%
C946	283-0622-00			450 pF	Mica	300 V	1%
C952	283-0004-00			0.02 $\mu$ F	Cer	150 V	
C954	290-0415-00			5.6 $\mu$ F	Elect.	35 V	10%
C956	283-0004-00			0.02 $\mu$ F	Cer	150 V	
C963	283-0594-00			0.001 $\mu$ F	Mica	100 V	1%
C964	283-0634-00			65 pF	Mica	100 V	1%
C965	283-0640-00			160 pF	Mica	100 V	1%
C966	283-0622-00			450 pF	Mica	300 V	1%
C972	283-0004-00			0.02 $\mu$ F	Cer	150 V	
C974	290-0415-00			5.6 $\mu$ F	Elect.	35 V	10%
C976	283-0004-00			0.02 $\mu$ F	Cer	150 V	
C981	290-0425-00			100 $\mu$ F	Elect.	20 V	
C982	290-0409-00			1000 $\mu$ F	Elect.	25 V	+75%—10%
C983	283-0594-00			0.001 $\mu$ F	Mica	100 V	1%
C984	283-0634-00			65 pF	Mica	100 V	1%
C985	283-0640-00			160 pF	Mica	100 V	1%
C986	283-0622-00			450 pF	Mica	300 V	1%
C989	290-0134-00			22 $\mu$ F	Elect.	15 V	
C992	283-0004-00			0.02 $\mu$ F	Cer	150 V	
C994	290-0415-00			5.6 $\mu$ F	Elect.	35 V	10%
C996	283-0004-00	B010100	B099999	0.02 $\mu$ F	Cer	150 V	
C996	283-0111-00	B100000		0.1 $\mu$ F	Cer	50 V	

Semiconductor Device, Diodes

CR120	*152-0185-00			Silicon	Replaceable by 1N4152
CR124	*152-0185-00			Silicon	Replaceable by 1N4152
CR125	*152-0185-00			Silicon	Replaceable by 1N4152
CR162	*152-0185-00			Silicon	Replaceable by 1N4152
CR164	*152-0185-00			Silicon	Replaceable by 1N4152
CR337	*152-0185-00			Silicon	Replaceable by 1N4152
CR347	*152-0185-00			Silicon	Replaceable by 1N4152
CR358	*152-0185-00			Silicon	Replaceable by 1N4152
CR359	*152-0185-00			Silicon	Replaceable by 1N4152
VR362	152-0226-00			Zener	1N751A 400 mW, 5.1 V, 5%
VR370	152-0168-00			Zener	1N963A 400 mW, 12 V, 5%
CR377	*152-0185-00			Silicon	Replaceable by 1N4152
CR378	*152-0185-00			Silicon	Replaceable by 1N4152
CR381	*152-0185-00			Silicon	Replaceable by 1N4152
CR385	152-0008-00			Germanium	
CR386	*152-0185-00			Silicon	Replaceable by 1N4152
CR392	*152-0269-00			Silicon	Voltage variable capacitance, Tek Spec
CR404	*152-0185-00			Silicon	Replaceable by 1N4152
CR405	*152-0185-00			Silicon	Replaceable by 1N4152
CR440	*152-0185-00			Silicon	Replaceable by 1N4152

Electrical Parts List—Type 141A/R141A

Semiconductor Device, Diodes (cont)

Ckt. No.	Tektronix Part No.	Serial/Model No. Eff	Disc		Description
CR441	*152-0185-00			Silicon	Replaceable by 1N4152
CR488	*152-0185-00			Silicon	Replaceable by 1N4152
CR501	*152-0185-00			Silicon	Replaceable by 1N4152
CR505	*152-0185-00	B010100	B029999	Silicon	Replaceable by 1N4152
CR505	152-0008-00	B030000		Germanium	
CR506	*152-0185-00			Silicon	Replaceable by 1N4152
CR507	*152-0185-00			Silicon	Replaceable by 1N4152
CR521	*152-0185-00			Silicon	Replaceable by 1N4152
CR525	*152-0185-00			Silicon	Replaceable by 1N4152
CR530	*152-0185-00			Silicon	Replaceable by 1N4152
CR535	*152-0185-00			Silicon	Replaceable by 1N4152
CR540	*152-0185-00			Silicon	Replaceable by 1N4152
CR545	*152-0185-00			Silicon	Replaceable by 1N4152
CR560	*152-0185-00			Silicon	Replaceable by 1N4152
CR701	*152-0185-00			Silicon	Replaceable by 1N4152
CR704	*152-0185-00			Silicon	Replaceable by 1N4152
CR707	*152-0185-00			Silicon	Replaceable by 1N4152
CR708	*152-0185-00			Silicon	Replaceable by 1N4152
CR709	*152-0185-00			Silicon	Replaceable by 1N4152
CR712	*152-0185-00			Silicon	Replaceable by 1N4152
CR735	*152-0185-00			Silicon	Replaceable by 1N4152
CR757	*152-0185-00			Silicon	Replaceable by 1N4152
CR771	*152-0185-00			Silicon	Replaceable by 1N4152
CR773	*152-0185-00			Silicon	Replaceable by 1N4152
CR775	*152-0185-00			Silicon	Replaceable by 1N4152
CR781	*152-0185-00			Silicon	Replaceable by 1N4152
CR783	*152-0185-00			Silicon	Replaceable by 1N4152
CR785	*152-0185-00			Silicon	Replaceable by 1N4152
CR791	*152-0185-00			Silicon	Replaceable by 1N4152
CR795	*152-0185-00			Silicon	Replaceable by 1N 152
CR811	152-0066-00			Silicon	1N3194
CR812	152-0066-00			Silicon	1N3194
CR813	152-0066-00			Silicon	1N3194
CR814	152-0066-00			Silicon	1N3194
CR815	*152-0185-00			Silicon	Replaceable by 1N4152
CR841	152-0198-00			Silicon	MR1032A 200 V PIV, 3A
CR842	152-0198-00			Silicon	MR1032A 200 V PIV, 3A
CR861	152-0066-00			Silicon	1N3194
CR862	152-0066-00			Silicon	1N3194
VR870	152-0212-00			Zener	1N936 500 mW, 9 V, 5%, TC
CR906	*152-0185-00			Silicon	Replaceable by 1N4152
CR926	*152-0185-00			Silicon	Replaceable by 1N4152
CR946	*152-0185-00			Silicon	Replaceable by 1N4152
CR966	*152-0185-00			Silicon	Replaceable by 1N4152
CR986	*152-0185-00			Silicon	Replaceable by 1N4152

Fuses

Ckt. No.	Tektronix Part No.	Serial/Model No. Eff	Disc		Description
F2	159-0025-00	B010100	B039999	1/2 A	3 AG Fast-Blo
F2	159-0042-00	B040000		3/4 A	3 AG Fast-Blo
F3	159-0028-00	B010100	B039999	1/4 A	3 AG Fast-Blo
F3	159-0025-00	B040000		1/2 A	3 AG Fast-Blo

Filter

FL1	119-0095-04	B010100	B079999	R1 2x 1 A, 275 VAC, 400 Hz
FL1	119-0095-06	B080000		R1 2x 1 A, 275 VAC, 400 Hz

Connectors

J16	131-0126-00			BNC, single contact
J18	131-0126-00			BNC, single contact
J36	131-0126-00			BNC, single contact
J37	131-0126-00			BNC, single contact
J39	131-0126-00			BNC, single contact
J50	131-0126-00			BNC, single contact
J52	131-0126-00			BNC, single contact
J78	131-0126-00			BNC, single contact
J79	131-0126-00			BNC, single contact
J82	131-0126-00			BNC, single contact
J84	131-0126-00			BNC, single contact
J86	131-0126-00			BNC, single contact
J88	131-0126-00			BNC, single contact
J90	131-0126-00			BNC, single contact
J92	131-0126-00			BNC, single contact
J94	131-0126-00			BNC, single contact
J96	131-0126-00			BNC, single contact

Inductors

L118	*108-0368-00			10 $\mu$ H
L337	*114-0278-00			4.6-16.7 $\mu$ H, Var Core 276-0568-00
L354	*114-0278-00			4.6-16.7 $\mu$ H, Var Core 276-0568-00
L357	*108-0095-00			1.4 $\mu$ H
L404	114-0177-00			280-650 $\mu$ H, Var Core 276-0506-00
L556	*114-0278-00			4.6-16.7 $\mu$ H, Var Core 276-0568-00
L557	*114-0278-00			4.6-16.7 $\mu$ H, Var Core 276-0568-00
L611	*114-0280-00			12-43 $\mu$ H, Var Core 276-0568-00
L621	*114-0280-00			12-43 $\mu$ H, Var Core 276-0568-00
L646	*114-0278-00			4.6-16.7 $\mu$ H, Var Core 276-0568-00
L661	*114-0280-00			12-43 $\mu$ H, Var Core 276-0568-00
L671	*114-0280-00			12-43 $\mu$ H, Var Core 276-0568-00
L691	*114-0281-00			35-70 $\mu$ H, Var Core 276-0540-00
L693	*114-0281-00			35-70 $\mu$ H, Var Core 276-0540-00
L715	*114-0222-00			2-6 $\mu$ H, Var Core 276-0568-00
L716	*114-0220-00			1-3 $\mu$ H, Var Core 276-0568-00
L725	*114-0278-00			4.6-16.7 $\mu$ H, Var Core 276-0568-00
L726	*114-0278-00			4.6-16.7 $\mu$ H, Var Core 276-0568-00
L904	*114-0278-00			4.6-16.7 $\mu$ H, Var Core 276-0568-00
L905	*114-0278-00			4.6-16.7 $\mu$ H, Var Core 276-0568-00

Electrical Parts List—Type 141A/R141A

Inductors (cont)

Ckt. No.	Tektronix Part No.	Serial/Model No. Eff	No. Disc	Description
L924	*114-0278-00			4.6-16.7 $\mu$ H, Var Core 276-0568-00
L925	*114-0278-00			4.6-16.7 $\mu$ H, Var Core 276-0568-00
L944	*114-0278-00			4.6-16.7 $\mu$ H, Var Core 276-0568-00
L945	*114-0278-00			4.6-16.7 $\mu$ H, Var Core 276-0568-00
L964	*114-0278-00			4.6-16.7 $\mu$ H, Var Core 276-0568-00
L965	*114-0278-00			4.6-16.7 $\mu$ H, Var Core 276-0568-00
L984	*114-0278-00			4.6-16.7 $\mu$ H, Var Core 276-0568-00
L985	*114-0278-00			4.6-16.7 $\mu$ H, Var Core 276-0568-00

Transistors

Q35	*151-0140-00			Silicon	Selected from 2N3055
Q55	*151-0140-00			Silicon	Selected from 2N3055
Q85	151-0149-00			Silicon	2N3441
Q105	*151-0198-00	B010100	B049999	Silicon	Replaceable by MPS 918
Q105	*151-0230-00	B050000		Silicon	Selected from RCA 40235
Q110	*151-0198-00			Silicon	Replaceable by MPS 918
Q115	*151-0198-00			Silicon	Replaceable by MPS 918
Q120	151-0188-00			Silicon	2N3906
Q130	*151-0195-00			Silicon	Replaceable by MPS 6515
Q135	*151-0195-00			Silicon	Replaceable by MPS 6515
Q140A,B	151-0249-00	B010100	B039999	Silicon	Dual
Q140A,B	151-0232-00	B040000		Silicon	Dual
Q150	*151-0195-00			Silicon	Replaceable by MPS 6515
Q155 <sup>1</sup>					
Q160	*151-0192-00			Silicon	Replaceable by MPS 6521
Q165	*151-0195-00			Silicon	Replaceable by MPS 6515
Q261	*151-0127-00	XB130000		Silicon	Selected from 2N2369
Q305	151-0224-00			Silicon	2N3692
Q306	151-0220-00			Silicon	2N4122
Q308	151-0224-00			Silicon	2N3692
Q310	151-1006-00			Silicon	FET
Q315	151-0220-00			Silicon	2N4122
Q320	151-1006-00			Silicon	FET
Q322	151-0220-00			Silicon	2N4122
Q325	151-0224-00			Silicon	2N3692
Q326	151-0224-00			Silicon	2N3692
Q330	151-0224-00			Silicon	2N3692
Q332	151-0224-00			Silicon	2N3692
Q335	151-0224-00			Silicon	2N3692
Q337	151-0224-00			Silicon	2N3692
Q345	151-0224-00			Silicon	2N3692
Q347	151-0224-00			Silicon	2N3692
Q355	151-0190-00			Silicon	2N3904
Q360	151-1011-00	B010100	B069999	Silicon	Dual, FET
Q360	151-1041-00	B070000		Silicon	Dual, FET
Q362	151-0220-00			Silicon	2N4122
Q366	*151-0216-00			Silicon	Replaceable by MOT MPS 6523
Q367	*151-0216-00			Silicon	Replaceable by MOT MPS 6523
Q372	151-0220-00			Silicon	2N4122

<sup>1</sup>Furnished as a unit with Oven Assembly (\*205-0108-01).



Transistors (cont)

Ckt. No.	Tektronix Part No.	Serial/Model No. Eff	Disc	Description
Q374	151-0224-00			Silicon 2N3692
Q378	151-0224-00			Silicon 2N3692
Q380	151-0224-00			Silicon 2N3692
Q385	151-0188-00			Silicon 2N3906
Q390	151-0220-00			Silicon 2N4122
Q395	151-0220-00			Silicon 2N4122
Q405	151-0224-00			Silicon 2N3692
Q410	151-0220-00			Silicon 2N4122
Q412	151-0220-00			Silicon 2N4122
Q418	*151-0198-00			Silicon Replaceable by MPS 918
Q420	151-0225-00			Silicon 2N3563
Q440	151-0224-00			Silicon 2N3692
Q445	151-0224-00			Silicon 2N3692
Q448	151-0224-00			Silicon 2N3692
Q450	151-0224-00			Silicon 2N3692
Q455	151-0224-00			Silicon 2N3692
Q460	151-0224-00			Silicon 2N3692
Q465	151-0224-00			Silicon 2N3692
Q470	151-0224-00			Silicon 2N3692
Q488	151-0188-00			Silicon 2N3906
Q495	151-0224-00			Silicon 2N3692
Q501	151-0164-00			Silicon 2N3702
Q505	151-0164-00			Silicon 2N3702
Q508	151-0220-00			Silicon 2N4122
Q510	151-0224-00			Silicon 2N3692
Q511	151-0224-00			Silicon 2N3692
Q512	151-0224-00			Silicon 2N3692
Q513	151-0224-00			Silicon 2N3692
Q515	*151-0192-00			Silicon Replaceable by MPS 6521
Q516	*151-0192-00			Silicon Replaceable by MPS 6521
Q520	151-0224-00			Silicon 2N3692
Q522	*151-0192-00			Silicon Replaceable by MPS 6521
Q526	151-0224-00			Silicon 2N3692
Q528	*151-0192-00			Silicon Replaceable by MPS 6521
Q530	151-0224-00			Silicon 2N3692
Q532	*151-0192-00			Silicon Replaceable by MPS 6521
Q536	151-0224-00			Silicon 2N3692
Q538	*151-0192-00			Silicon Replaceable by MPS 6521
Q540	151-0224-00			Silicon 2N3692
Q542	*151-0192-00			Silicon Replaceable by MPS 6521
Q546	151-0224-00			Silicon 2N3692
Q548	*151-0192-00			Silicon Replaceable by MPS 6521
Q550	151-0224-00	B010100	B039999	Silicon 2N3692
Q550	151-0225-00	B040000		Silicon 2N3563
Q552	*151-0192-00			Silicon Replaceable by MPS 6521
Q556	151-0220-00			Silicon 2N4122

Electrical Parts List—Type 141A/R141A

Transistors (cont)

Ckt. No.	Tektronix Part No.	Serial/Model No. Eff	No. Disc	Description
Q558	151-0220-00			Silicon 2N4122
Q560	151-0220-00			Silicon 2N4122
Q570	151-0221-00			Silicon 2N4258
Q572	151-0164-00			Silicon 2N3702
Q574	151-0190-00			Silicon 2N3904
Q576	151-0164-00			Silicon 2N3702
Q605 } Q606 } Q607 } Q608 }	*153-0577-00			Silicon (matched set of 4) Tek Spec
Q610	*151-0195-00			Silicon Replaceable by MPS 6515
Q620	*151-0195-00			Silicon Replaceable by MPS 6515
Q630	151-0224-00			Silicon 2N3692
Q635	151-0232-00			Silicon Dual
Q640	151-0225-00			Silicon 2N3563
Q642	151-0225-00			Silicon 2N3563
Q644	151-0225-00			Silicon 2N3563
Q646	151-0225-00			Silicon 2N3563
Q655 } Q656 } Q657 } Q658 }	*153-0577-00			Silicon (matched set of 4) Tek Spec
Q660	*151-0195-00			Silicon Replaceable by MPS 6515
Q670	*151-0195-00			Silicon Replaceable by MPS 6515
Q680	151-0224-00			Silicon 2N3692
Q685	151-0232-00			Silicon Dual
Q701	151-0190-00			Silicon 2N3904
Q702	*151-0192-00			Silicon Replaceable by MPS 6521
Q703	151-0190-00			Silicon 2N3904
Q704	151-0190-00			Silicon 2N3904
Q705	151-0190-00			Silicon 2N3904
Q706	*151-0192-00			Silicon Replaceable by MPS 6521
Q707	*151-0192-00			Silicon Replaceable by MPS 6521
Q708	151-0190-00			Silicon 2N3904
Q709	151-0190-00			Silicon 2N3904
Q710	*151-0192-00			Silicon Replaceable by MPS 6521
Q712	151-0190-00			Silicon 2N3904
Q714	*151-0192-00			Silicon Replaceable by MPS 6521
Q715	*151-0192-00			Silicon Replaceable by MPS 6521
Q720	151-0220-00			Silicon 2N4122
Q725	*151-0192-00			Silicon Replaceable by MPS 6521
Q735	*151-0192-00			Silicon Replaceable by MPS 6521
Q740	151-0220-00	B010100	B039999	Silicon 2N4122
Q740	*151-0219-00	B040000		Silicon Replaceable by 2N4250
Q745	151-0220-00			Silicon 2N4122
Q748	*151-0103-00			Silicon Replaceable by 2N2219
Q750	151-0220-00			Silicon 2N4122
Q751	*151-0216-00			Silicon Replaceable by MOT MPS 6523

## Transistors (cont)

Ckt. No.	Tektronix Part No.	Serial/Model No. Eff Disc		Description
Q752	*151-0216-00		Silicon	Replaceable by MOT MPS 6523
Q753	151-0188-00		Silicon	2N3906
Q755	*151-0192-00		Silicon	Replaceable by MPS 6521
Q760	151-0220-00		Silicon	2N4122
Q765	151-0220-00		Silicon	2N4122
Q768	*151-0103-00		Silicon	Replaceable by 2N2219
Q771	151-0190-00		Silicon	2N3904
Q772	*151-0192-00		Silicon	Replaceable by MPS 6521
Q773	151-0190-00		Silicon	2N3904
Q774	*151-0192-00		Silicon	Replaceable by MPS 6521
Q775	151-0190-00		Silicon	2N3904
Q776	*151-0192-00		Silicon	Replaceable by MPS 6521
Q781	151-0190-00		Silicon	2N3904
Q782	*151-0192-00		Silicon	Replaceable by MPS 6521
Q783	151-0190-00		Silicon	2N3904
Q784	*151-0192-00		Silicon	Replaceable by MPS 6521
Q785	151-0190-00		Silicon	2N3904
Q786	*151-0192-00		Silicon	Replaceable by MPS 6521
Q790	151-0190-00		Silicon	2N3904
Q792	*151-0192-00		Silicon	Replaceable by MPS 6521
Q794	151-0190-00		Silicon	2N3904
Q796	*151-0192-00		Silicon	Replaceable by MPS 6521
Q810	151-0224-00		Silicon	2N3692
Q815	151-1005-00		Silicon	FET
Q825	*151-0192-00		Silicon	Replaceable by MPS 6521
Q826	*151-0192-00		Silicon	Replaceable by MPS 6521
Q830	*151-0183-00		Silicon	Selected from 2N2192
Q840	151-0224-00		Silicon	2N3692
Q845	*151-0192-00		Silicon	Replaceable by MPS 6521
Q846	*151-0192-00		Silicon	Replaceable by MPS 6521
Q850	*151-0183-00		Silicon	Selected from 2N2192
Q860	151-0224-00		Silicon	2N3692
Q875	*151-0192-00		Silicon	Replaceable by MPS 6521
Q876	*151-0192-00		Silicon	Replaceable by MPS 6521
Q880	*151-0183-00		Silicon	Selected from 2N2192
Q900	151-0220-00		Silicon	2N4122
Q902	151-0220-00		Silicon	2N4122
Q910	151-0220-00		Silicon	2N4122
Q912	151-0221-00		Silicon	2N4258
Q914	151-0190-00		Silicon	2N3904
Q916	151-0164-00		Silicon	2N3702
Q920	151-0220-00		Silicon	2N4122
Q922	151-0220-00		Silicon	2N4122
Q930	151-0220-00		Silicon	2N4122
Q932	151-0221-00		Silicon	2N4258

# Electrical Parts List—Type 141A/R141A

## Transistors (cont)

Ckt. No.	Tektronix Part No.	Serial/Model No. Eff	Disc	Description
Q934	151-0190-00		Silicon	2N3904
Q936	151-0164-00		Silicon	2N3702
Q940	151-0220-00		Silicon	2N4122
Q942	151-0220-00		Silicon	2N4122
Q950	151-0220-00		Silicon	2N4122
Q952	151-0221-00		Silicon	2N4258
Q954	151-0190-00		Silicon	2N3904
Q956	151-0164-00		Silicon	2N3702
Q960	151-0220-00		Silicon	2N4122
Q962	151-0220-00		Silicon	2N4122
Q964	151-0190-00		Silicon	2N3904
Q970	151-0220-00		Silicon	2N4122
Q972	151-0221-00		Silicon	2N4258
Q974	151-0190-00		Silicon	2N3904
Q976	151-0164-00		Silicon	2N3702
Q978	151-0164-00		Silicon	2N3702
Q980	151-0220-00		Silicon	2N4122
Q982	151-0220-00		Silicon	2N4122
Q990	151-0220-00		Silicon	2N4122
Q992	151-0221-00		Silicon	2N4258
Q994	151-0190-00		Silicon	2N3904
Q996	151-0164-00		Silicon	2N3702
Q998	151-0164-00		Silicon	2N3702

## Resistors

Resistors are fixed, composition,  $\pm 10\%$  unless otherwise indicated.

R20	321-0329-00	26.1 k $\Omega$	1/8 W	Prec	1%
R21	321-0283-00	8.66 k $\Omega$	1/8 W	Prec	1%
R22	321-0254-00	4.32 k $\Omega$	1/8 W	Prec	1%
R23	321-0233-00	2.61 k $\Omega$	1/8 W	Prec	1%
R24	321-0216-00	1.74 k $\Omega$	1/8 W	Prec	1%
R25	321-0202-00	1.24 k $\Omega$	1/8 W	Prec	1%
R26	321-0190-00	931 $\Omega$	1/8 W	Prec	1%
R27	321-0180-00	732 $\Omega$	1/8 W	Prec	1%
R28	321-0170-00	576 $\Omega$	1/8 W	Prec	1%
R105	321-0354-00	47.5 k $\Omega$	1/8 W	Prec	1%
R106	321-0354-00	47.5 k $\Omega$	1/8 W	Prec	1%
R108	321-0306-00	15 k $\Omega$	1/8 W	Prec	1%
R109	317-0101-00	100 $\Omega$	1/8 W		5%
R111	321-0339-00	33.2 k $\Omega$	1/8 W	Prec	1%
R113	315-0102-00	1 k $\Omega$	1/4 W		5%
R115	321-0235-00	2.74 k $\Omega$	1/8 W	Prec	1%
R118	315-0101-00	100 $\Omega$	1/4 W		5%
R120	315-0472-00	4.7 k $\Omega$	1/4 W		5%
R124	315-0911-00	910 $\Omega$	1/4 W		5%
R125	315-0105-00	1 M $\Omega$	1/4 W		5%

## Resistors (cont)

Ckt. No.	Tektronix Part No.	Serial/Model No. Eff	Disc	Description		
R126	315-0332-00		3.3 k $\Omega$	1/4 W		5%
R128	315-0910-00		91 $\Omega$	1/4 W		5%
R131	315-0100-00		10 $\Omega$	1/4 W		5%
R134	315-0910-00		91 $\Omega$	1/4 W		5%
R136	315-0750-00		75 $\Omega$	1/4 W		5%
R137	315-0750-00		75 $\Omega$	1/4 W		5%
R139	315-0750-00		75 $\Omega$	1/4 W		5%
R141	322-0157-00		422 $\Omega$	1/4 W	Prec	1%
R142 <sup>2</sup>						
R143 <sup>2</sup>						
R144 <sup>2</sup>						
R145 <sup>2</sup>						
R147	321-0237-00		2.87 k $\Omega$	1/8 W	Prec	1%
R149	321-0249-00		3.83 k $\Omega$	1/8 W	Prec	1%
R152	315-0271-00		270 $\Omega$	1/4 W		5%
R154	315-0332-00		3.3 k $\Omega$	1/4 W		5%
R155 <sup>2</sup>						
R161	315-0302-00		3 k $\Omega$	1/4 W		5%
R162	315-0272-00		2.7 k $\Omega$	1/4 W		5%
R164	315-0203-00		20 k $\Omega$	1/4 W		5%
R166	315-0303-00		30 k $\Omega$	1/4 W		5%
R229	315-0392-00		3.9 k $\Omega$	1/4 W		5%
R241	315-0272-00		2.7 k $\Omega$	1/4 W		5%
R242	315-0272-00		2.7 k $\Omega$	1/4 W		5%
R243	315-0272-00		2.7 k $\Omega$	1/4 W		5%
R244	315-0272-00		2.7 k $\Omega$	1/4 W		5%
R245	315-0243-00		24 k $\Omega$	1/4 W		5%
R246	315-0202-00		2 k $\Omega$	1/4 W		5%
R247	315-0243-00		24 k $\Omega$	1/4 W		5%
R248	315-0202-00		2 k $\Omega$	1/4 W		5%
R257	315-0243-00		24 k $\Omega$	1/4 W		5%
R258	315-0202-00		2 k $\Omega$	1/4 W		5%
R260	322-0247-00	XB130000	3.65 k $\Omega$	1/4 W	Prec	1%
R261	311-1265-00	XB130000	2 k $\Omega$ , Var			
R264	315-0152-00	XB130000	1.5 k $\Omega$	1/4 W		5%
R266	315-0152-00	XB130000	1.5 k $\Omega$	1/4 W		5%
R301	315-0103-00		10 k $\Omega$	1/4 W		5%
R303	315-0103-00		10 k $\Omega$	1/4 W		5%
R304	315-0103-00		10 k $\Omega$	1/4 W		5%
R305	315-0472-00		4.7 k $\Omega$	1/4 W		5%
R307	315-0103-00		10 k $\Omega$	1/4 W		5%
R308	315-0103-00		10 k $\Omega$	1/4 W		5%
R309	315-0474-00		470 k $\Omega$	1/4 W		5%
R311	321-0369-00		68.1 k $\Omega$	1/8 W	Prec	1%
R312	323-0656-00		1.5 M $\Omega$	1/2 W	Prec	1/2%
R313	311-0624-00	B010100	200 k $\Omega$ , Var			
R313	311-1251-00	B110000	200 k $\Omega$ , Var			
R314	321-0366-00		63.4 k $\Omega$	1/8 W	Prec	1%
R316	315-0153-00		15 k $\Omega$	1/4 W		5%
R318	315-0153-00		15 k $\Omega$	1/4 W		5%

<sup>2</sup>Furnished as a unit with Oven Assembly (\*205-0108-01).

Electrical Parts List—Type 141A/R141A

Resistors (cont)

Ckt. No.	Tektronix Part No.	Serial/Model No. Eff	Disc	Description		
R320	321-0365-00		61.9 kΩ	1/8 W	Prec	1%
R322	315-0153-00		15 kΩ	1/4 W		5%
R323	315-0105-00		1 MΩ	1/4 W		5%
R324	315-0153-00		15 kΩ	1/4 W		5%
R325	315-0103-00		10 kΩ	1/4 W		5%
R327	315-0103-00		10 kΩ	1/4 W		5%
R328	321-0162-00		475 Ω	1/8 W	Prec	1%
R329	321-0162-00		475 Ω	1/8 W	Prec	1%
R330	315-0103-00		10 kΩ	1/4 W		5%
R332	315-0103-00		10 kΩ	1/4 W		5%
R334	321-0162-00		475 Ω	1/8 W	Prec	1%
R335	321-0162-00		475 Ω	1/8 W	Prec	1%
R337	321-0123-00		187 Ω	1/8 W	Prec	1%
R338	315-0162-00		1.6 kΩ	1/8 W		5%
R339	315-0102-00		1 kΩ	1/4 W		5%
R345	315-0470-00		47 Ω	1/4 W		5%
R346	315-0622-00		6.2 kΩ	1/4 W		5%
R347	321-0123-00		187 Ω	1/8 W	Prec	1%
R348	315-0103-00		10 kΩ	1/4 W		5%
R349	315-0102-00		1 kΩ	1/4 W		5%
R351	315-0102-00		1 kΩ	1/4 W		5%
R352	315-0242-00		2.4 kΩ	1/4 W		5%
R353	315-0302-00		3 kΩ	1/4 W		5%
R355	315-0150-00		15 Ω	1/4 W		5%
R356	315-0910-00		91 Ω	1/4 W		5%
R358	321-0510-00		2 MΩ	1/8 W	Prec	1%
R359	321-0510-00		2 MΩ	1/8 W	Prec	1%
R360	315-0363-00		36 kΩ	1/4 W		5%
R361	315-0564-00		560 kΩ	1/4 W		5%
R363	315-0472-00		4.7 kΩ	1/4 W		5%
R364	315-0392-00		4.7 kΩ	1/4 W		5%
R365	315-0101-00		100 Ω	1/4 W		5%
R366	315-0101-00		100 Ω	1/4 W		5%
R369	315-0153-00		15 kΩ	1/4 W		5%
R370	315-0752-00		7.5 kΩ	1/4 W		5%
R371	315-0106-00		10 MΩ	1/4 W		5%
R373	315-0202-00		2 kΩ	1/4 W		5%
R374	315-0363-00		36 kΩ	1/4 W		5%
R375	315-0472-00		4.7 kΩ	1/4 W		5%
R377	315-0624-00		620 kΩ	1/4 W		5%
R380	315-0562-00		5.6 kΩ	1/4 W		5%
R381	315-0333-00		33 kΩ	1/4 W		5%
R382	315-0471-00		470 Ω	1/4 W		5%
R383	315-0134-00		130 kΩ	1/4 W		5%
R384	315-0183-00		18 kΩ	1/4 W		5%

## Resistors (cont)

Ckt. No.	Tektronix Part No.	Serial/Model No. Eff	Disc	Description		
R385	315-0331-00			330 $\Omega$	$\frac{1}{4}$ W	5%
R386	315-0124-00			120 k $\Omega$	$\frac{1}{4}$ W	5%
R387	315-0243-00			24 k $\Omega$	$\frac{1}{4}$ W	5%
R388	315-0202-00			2 k $\Omega$	$\frac{1}{4}$ W	5%
R389	315-0243-00			24 k $\Omega$	$\frac{1}{4}$ W	5%
R390	315-0202-00			2 k $\Omega$	$\frac{1}{4}$ W	5%
R391	315-0124-00			120 k $\Omega$	$\frac{1}{4}$ W	5%
R392	315-0124-00			120 k $\Omega$	$\frac{1}{4}$ W	5%
R393	315-0753-00			75 k $\Omega$	$\frac{1}{4}$ W	5%
R394	315-0753-00			75 k $\Omega$	$\frac{1}{4}$ W	5%
R395	315-0561-00			560 $\Omega$	$\frac{1}{4}$ W	5%
R396	315-0300-00			30 $\Omega$	$\frac{1}{4}$ W	5%
R398	315-0153-00			15 k $\Omega$	$\frac{1}{4}$ W	5%
R399	315-0121-00			120 $\Omega$	$\frac{1}{4}$ W	5%
R401	315-0202-00			2 k $\Omega$	$\frac{1}{4}$ W	5%
R402	315-0243-00			24 k $\Omega$	$\frac{1}{4}$ W	5%
R403	315-0470-00			47 $\Omega$	$\frac{1}{4}$ W	5%
R405	315-0681-00			680 $\Omega$	$\frac{1}{4}$ W	5%
R406	315-0681-00			680 $\Omega$	$\frac{1}{4}$ W	5%
R408	315-0273-00			27 k $\Omega$	$\frac{1}{4}$ W	5%
R409	315-0470-00			47 $\Omega$	$\frac{1}{4}$ W	5%
R410	315-0202-00			2 k $\Omega$	$\frac{1}{4}$ W	5%
R412	315-0132-00			1.3 k $\Omega$	$\frac{1}{4}$ W	5%
R413	315-0470-00			47 $\Omega$	$\frac{1}{4}$ W	5%
R414	315-0473-00			47 k $\Omega$	$\frac{1}{4}$ W	5%
R415	315-0102-00			1 k $\Omega$	$\frac{1}{4}$ W	5%
R416	315-0471-00			470 $\Omega$	$\frac{1}{4}$ W	5%
R418	311-0953-00	B010100	B109999	2.5 k $\Omega$ , Var		
R418	311-1266-00	B110000		2.5 k $\Omega$ , Var		
R419	321-0193-00			1 k $\Omega$	$\frac{1}{8}$ W	Prec 1%
R420	315-0102-00			1 k $\Omega$	$\frac{1}{4}$ W	5%
R422	315-0681-00			680 $\Omega$	$\frac{1}{4}$ W	5%
R425	315-0821-00			820 $\Omega$	$\frac{1}{4}$ W	5%
R430	315-0243-00			24 k $\Omega$	$\frac{1}{4}$ W	5%
R431	315-0202-00			2 k $\Omega$	$\frac{1}{4}$ W	5%
R434	315-0243-00			24 k $\Omega$	$\frac{1}{4}$ W	5%
R435	315-0202-00			2 k $\Omega$	$\frac{1}{4}$ W	5%
R439	315-0100-00			10 $\Omega$	$\frac{1}{4}$ W	5%
R440	315-0471-00			470 $\Omega$	$\frac{1}{4}$ W	5%
R441	321-0319-00			20.5 k $\Omega$	$\frac{1}{8}$ W	Prec 1%
R443	315-0223-00			22 k $\Omega$	$\frac{1}{4}$ W	5%
R444	315-0103-00			10 k $\Omega$	$\frac{1}{4}$ W	5%
R450	321-0232-00			2.55 k $\Omega$	$\frac{1}{8}$ W	Prec 1%
R451	311-0732-00	B010100	B109999	1 k $\Omega$ , Var		
R451	311-1263-00	B110000		1 k $\Omega$ , Var		
R452	321-0350-00			43.2 k $\Omega$	$\frac{1}{8}$ W	Prec 1%
R454	315-0821-00			820 $\Omega$	$\frac{1}{4}$ W	5%

Electrical Parts List—Type 141A/R141A

Resistors (cont)

Ckt. No.	Tektronix Part No.	Serial/Model No. Eff	Disc	Description			
R455	321-0243-00			3.32 kΩ	1/8 W	Prec	1%
R456	311-0704-00	B010100	B109999	500 Ω, Var			
R456	311-1261-00	B110000		500 Ω, Var			
R457	321-0314-00			18.2 kΩ	1/8 W	Prec	1%
R459	315-0222-00			2.2 kΩ	1/4 W		5%
R460	321-0247-00			3.65 kΩ	1/8 W	Prec	1%
R461	311-0704-00	B010100	B109999	500 Ω, Var			
R461	311-1261-00	B110000		500 Ω, Var			
R462	321-0298-00			12.4 kΩ	1/8 W	Prec	1%
R464	315-0152-00			1.5 kΩ	1/4 W		5%
R465	321-0249-00			3.83 kΩ	1/8 W	Prec	1%
R466	311-0704-00	B010100	B109999	500 Ω, Var			
R466	311-1261-00	B110000		500 Ω, Var			
R467	321-0295-00			11.5 kΩ	1/8 W	Prec	1%
R469	315-0222-00			2.2 kΩ	1/4 W		5%
R470	321-0252-00			4.12 kΩ	1/8 W	Prec	1%
R471	311-0704-00	B010100	B109999	500 Ω, Var			
R471	311-1261-00	B110000		500 Ω, Var			
R472	321-0286-00			9.31 kΩ	1/8 W	Prec	1%
R474	315-0222-00			2.2 kΩ	1/4 W		5%
R476	315-0243-00			24 kΩ	1/4 W		5%
R478	315-0202-00			2 kΩ	1/4 W		5%
R480	315-0100-00			10 Ω	1/4 W		5%
R481	315-0100-00			10 Ω	1/4 W		5%
R484	315-0243-00			24 kΩ	1/4 W		5%
R485	315-0202-00			2 kΩ	1/4 W		5%
R488	315-0681-00			680 Ω	1/4 W		5%
R489	315-0102-00			1 kΩ	1/4 W		5%
R490	315-0100-00			10 Ω	1/4 W		5%
R491	321-0252-00			4.12 kΩ	1/8 W	Prec	1%
R492	311-0704-00	B010100	B109999	500 Ω, Var			
R492	311-1261-00	B110000		500 Ω, Var			
R493	321-0287-00			9.53 kΩ	1/8 W	Prec	1%
R495	315-0222-00			2.2 kΩ	1/4 W		5%
R497	315-0202-00			2 kΩ	1/4 W		5%
R501	315-0332-00			3.3 kΩ	1/4 W		5%
R503	315-0273-00			27 kΩ	1/4 W		5%
R504	315-0821-00			820 Ω	1/4 W		5%
R507	315-0273-00			27 kΩ	1/4 W		5%
R508	315-0102-00			1 kΩ	1/4 W		5%
R511	321-0435-00			332 kΩ	1/8 W	Prec	1%
R512	315-0470-00			47 Ω	1/4 W		5%
R513	321-0262-01			5.23 kΩ	1/8 W	Prec	1/2%
R514	315-0470-00			47 Ω	1/4 W		5%
R519	315-0243-00			24 kΩ	1/4 W		5%
R520	315-0202-00			2 kΩ	1/4 W		5%
R521	311-0644-00			20 kΩ, Var			
R522	321-0361-00	B010100	B099999	56.2 kΩ	1/8 W	Prec	1%
R522	321-0368-00	B100000		66.5 kΩ	1/8 W	Prec	1%
R523	315-0101-00			100 Ω	1/4 W		5%
R524	315-0432-00			4.3 kΩ	1/4 W		5%



## Resistors (cont)

Ckt. No.	Tektronix Part No.	Serial/Model No. Eff	Disc	Description			
R679	321-0122-00			182 $\Omega$	$\frac{1}{8}$ W	Prec	1%
R680	315-0202-00			2 k $\Omega$	$\frac{1}{4}$ W		5%
R684	321-0161-00	B010100	B039999	464 $\Omega$	$\frac{1}{8}$ W	Prec	1%
R684	321-0812-07	B040000		455 $\Omega$	$\frac{1}{8}$ W	Prec	1/10%
R686	321-0161-00	B010100	B039999	464 $\Omega$	$\frac{1}{8}$ W	Prec	1%
R686	321-0812-07	B040000		455 $\Omega$	$\frac{1}{8}$ W	Prec	1/10%
R692	321-0240-00	B010100	B039999	3.09 k $\Omega$	$\frac{1}{8}$ W	Prec	1%
R692	321-0210-00	B040000		1.5 k $\Omega$	$\frac{1}{8}$ W	Prec	1%
R694	315-0100-00			10 $\Omega$	$\frac{1}{4}$ W		5%
R696	315-0100-00			10 $\Omega$	$\frac{1}{4}$ W		5%
R698	315-0100-00			10 $\Omega$	$\frac{1}{4}$ W		5%
R700	315-0101-00			100 $\Omega$	$\frac{1}{4}$ W		5%
R701	321-0345-00	B010100	B099999	38.3 k $\Omega$	$\frac{1}{8}$ W	Prec	1%
R701	321-0351-00	B100000		44.2 k $\Omega$	$\frac{1}{8}$ W	Prec	1%
R702	311-0840-00	B010100	B099999	20 k $\Omega$ , Var			
R702	311-0836-00	B100000	B109999	5 k $\Omega$ , Var			
R702	311-1267-00	B110000		5 k $\Omega$ , Var			
R703	321-0300-00			13 k $\Omega$	$\frac{1}{8}$ W	Prec	1%
R704	321-0305-00	B010100	B099999	14.7 k $\Omega$	$\frac{1}{8}$ W	Prec	1%
R704	321-0310-00	B100000		16.5 k $\Omega$	$\frac{1}{8}$ W	Prec	1%
R705	311-0836-00	B010100	B099999	5 k $\Omega$ , Var			
R705	311-1016-00	B100000	B109999	2 k $\Omega$ , Var			
R705	311-1265-00	B110000		2 k $\Omega$ , Var			
R706	311-0836-00	B010100	B109999	5 k $\Omega$ , Var			
R706	311-1267-00	B110000		5 k $\Omega$ , Var			
R707	315-0511-00			510 $\Omega$	$\frac{1}{4}$ W		5%
R708	321-0269-00	B010100	B099999	6.19 k $\Omega$	$\frac{1}{8}$ W	Prec	1%
R708	321-0282-00	B100000		8.45 k $\Omega$	$\frac{1}{8}$ W	Prec	1%
R709	311-0836-00	B010100	B099999	5 k $\Omega$ , Var			
R709	311-0732-00	B100000	B109999	1 k $\Omega$ , Var			
R709	311-1263-00	B110000		1 k $\Omega$ , Var			
R710	315-0222-00			2.2 k $\Omega$	$\frac{1}{4}$ W		5%
R711	315-0222-00			2.2 k $\Omega$	$\frac{1}{4}$ W		5%
R712	321-0300-00			13 k $\Omega$	$\frac{1}{8}$ W	Prec	1%
R713	311-0836-00	B010100	B109999	5 k $\Omega$ , Var			
R713	311-1267-00	B110000		5 k $\Omega$ , Var			
R714	315-0101-00			100 $\Omega$	$\frac{1}{4}$ W		5%
R715	321-0294-00			11.3 k $\Omega$	$\frac{1}{8}$ W	Prec	1%
R717	321-0105-00	B010100	B059999	121 $\Omega$	$\frac{1}{8}$ W	Prec	1%
R717	321-0108-00	B060000		130 $\Omega$	$\frac{1}{8}$ W	Prec	1%
R719	315-0101-00			100 $\Omega$	$\frac{1}{4}$ W		5%
R722	315-0752-00			7.5 k $\Omega$	$\frac{1}{4}$ W		5%
R723	315-0102-00			1 k $\Omega$	$\frac{1}{4}$ W		5%
R724	315-0102-00			1 k $\Omega$	$\frac{1}{4}$ W		5%
R727	321-0117-00			162 $\Omega$	$\frac{1}{8}$ W	Prec	1%
R729	315-0101-00			100 $\Omega$	$\frac{1}{4}$ W		5%
R730	311-0950-00	B010100	B109999	10 k $\Omega$ , Var			
R730	311-1268-00	B110000		10 k $\Omega$ , Var			
R731	315-0273-00			27 k $\Omega$	$\frac{1}{4}$ W		5%
R732	321-0201-00	B010100	B099999	1.21 k $\Omega$	$\frac{1}{8}$ W	Prec	1%
R732	321-0198-00	B100000		1.13 k $\Omega$	$\frac{1}{8}$ W	Prec	1%
R734	321-0241-00			3.16 k $\Omega$	$\frac{1}{8}$ W	Prec	1%
R735	321-0228-00			2.32 k $\Omega$	$\frac{1}{8}$ W	Prec	1%
R736	321-0172-00			604 $\Omega$	$\frac{1}{8}$ W	Prec	1%
R738	321-0231-00			2.49 k $\Omega$	$\frac{1}{8}$ W	Prec	1%
R740	315-0431-00			430 $\Omega$	$\frac{1}{4}$ W		5%

Electrical Parts List—Type 141A/R141A

Resistors (cont)

Kct. No.	Tektronix Part No.	Serial/Model No. Eff	Disc	Description			
R742	321-0210-00			1.5 kΩ	1/8 W	Prec	1%
R743	321-0210-00			1.5 kΩ	1/8 W	Prec	1%
R744	315-0302-00			3 kΩ	1/4 W		5%
R745	308-0314-00			680 Ω	3 W	WW	5%
R746	321-0182-00			768 Ω	1/8 W	Prec	1%
R747	311-0886-00	B010100	B109999	50 Ω, Var			
R747	311-1258-00	B110000		50 Ω, Var			
R748 } R749 }	*312-0656-00			121 Ω	1/8 W	Prec	(matched to within 0.1%)
R750	321-1263-02			5.42 kΩ	1/8 W	Prec	1/2%
R751	321-0641-01			1.8 kΩ	1/8 W	Prec	1/2%
R752	315-0512-00			5.1 kΩ	1/4 W		5%
R753	315-0302-00			3 kΩ	1/4 W		5%
R754	321-0193-00			1 kΩ	1/8 W	Prec	1%
R755	321-0277-00			7.5 kΩ	1/8 W	Prec	1%
R756	315-0102-00			1 kΩ	1/4 W		5%
R757	315-0512-00			5.1 kΩ	1/4 W		5%
R758	321-0231-00			2.49 kΩ	1/8 W	Prec	1%
R760	315-0431-00			430 Ω	1/4 W		5%
R762	321-0210-00			1.5 kΩ	1/8 W	Prec	1%
R763	321-0210-00			1.5 kΩ	1/8 W	Prec	1%
R764	315-0302-00			3 kΩ	1/4 W		5%
R765	308-0252-00			390 Ω	3 W	WW	5%
R766	321-0216-00	B010100	B039999	1.74 kΩ	1/8 W	Prec	1%
R766	321-0222-00	B040000	B099999	2 kΩ	1/8 W	Prec	1%
R766	321-0228-00	B100000		2.32 kΩ	1/8 W	Prec	1%
R767	311-0704-00	B010100	B109999	500 Ω, Var			
R767	311-1261-00	B110000		500 Ω, Var			
R768 } R769 }	*312-0657-00			200 Ω	1/8 W	Prec	(matched to within 0.1%)
R770	315-0101-00			100 Ω	1/4 W		5%
R771	321-0303-00	B010100	B099999	14 kΩ	1/8 W	Prec	1%
R771	321-0307-00	B100000		15.4 kΩ	1/8 W	Prec	1%
R772	311-0836-00	B010100	B099999	5 kΩ, Var			
R772	311-1016-00	B100000	B109999	2 kΩ, Var			
R772	311-1265-00	B110000		2 kΩ, Var			
R773	321-0349-00	B010100	B099999	42.2 kΩ	1/8 W	Prec	1%
R773	321-0353-00	B100000		46.4 kΩ	1/8 W	Prec	1%
R774	311-0950-00	B010100	B099999	10 kΩ, Var			
R774	311-0836-00	B100000	B109999	5 kΩ, Var			
R774	311-1267-00	B110000		5 kΩ, Var			
R775	321-0319-00	B010100	B099999	20.5 kΩ	1/8 W	Prec	1%
R775	321-0324-00	B100000		23.2 kΩ	1/8 W	Prec	1%
R776	311-0950-00	B010100	B099999	10 kΩ, Var			
R776	311-0953-00	B100000	B109999	2.5 kΩ, Var			
R776	311-1266-00	B110000		2.5 kΩ, Var			
R777	315-0102-00			1 kΩ	1/4 W		5%
R778	315-0101-00			100 Ω	1/4 W		5%
R779	315-0101-00			100 Ω	1/4 W		5%
R780	315-0681-00			680 Ω	1/4 W		5%
R781	321-0365-00	B010100	B099999	61.9 kΩ	1/8 W	Prec	1%
R781	321-0368-00	B100000		66.5 kΩ	1/8 W	Prec	1%
R782	311-0840-00	B010100	B099999	20 kΩ, Var			
R782	311-0950-00	B100000	B109999	10 kΩ, Var			
R782	311-1268-00	B110000		10 kΩ, Var			
R783	321-0268-00	B010100	B099999	9.31 kΩ	1/8 W	Prec	1%

## Resistors (cont)

Ckt. No.	Tektronix Part No.	Serial/Model No. Eff	Disc	Description		
R525	321-0325-00			23.7 k $\Omega$	1/8 W	Prec 1%
R526	311-0633-00			5 k $\Omega$ , Var		
R527	315-0751-00			750 $\Omega$	1/4 W	5%
R528	315-0101-00			100 $\Omega$	1/4 W	5%
R530	321-0325-00			23.7 k $\Omega$	1/8 W	Prec 1%
R531	311-0633-00			5 k $\Omega$ , Var		
R533	315-0101-00			100 $\Omega$	1/4 W	5%
R535	321-0325-00			23.7 k $\Omega$	1/8 W	Prec 1%
R536	311-0633-00			5 k $\Omega$ , Var		
R538	315-0101-00			100 $\Omega$	1/4 W	5%
R540	321-0325-00			23.7 k $\Omega$	1/8 W	Prec 1%
R541	311-0633-00			5 k $\Omega$ , Var		
R543	315-0101-00			100 $\Omega$	1/4 W	5%
R545	321-0325-00			23.7 k $\Omega$	1/8 W	Prec 1%
R546	311-0633-00			5 k $\Omega$ , Var		
R548	315-0101-00			100 $\Omega$	1/4 W	5%
R550	321-0293-00			11 k $\Omega$	1/8 W	Prec 1%
R551	311-0609-00			2 k $\Omega$ , Var		
R552	315-0101-00			100 $\Omega$	1/4 W	5%
R553	321-0294-00			11.3 k $\Omega$	1/8 W	Prec 1%
R554	315-0152-00			1.5 k $\Omega$	1/4 W	5%
R555	321-0222-00			2 k $\Omega$	1/8 W	Prec 1%
R556	321-0193-00			1 k $\Omega$	1/8 W	Prec 1%
R557	321-0285-00			9.09 k $\Omega$	1/8 W	Prec 1%
R558	315-0220-00			22 $\Omega$	1/4 W	5%
R559	321-0117-00			162 $\Omega$	1/8 W	Prec 1%
R561	315-0103-00			10 k $\Omega$	1/4 W	5%
R563	321-0275-00			7.15 k $\Omega$	1/8 W	Prec 1%
R565	321-0260-00			4.99 k $\Omega$	1/8 W	Prec 1%
R567	321-0222-00			2 k $\Omega$	1/8 W	Prec 1%
R569	315-0202-00			2 k $\Omega$	1/4 W	5%
R570	307-0113-00			5.1 k $\Omega$	1/4 W	5%
R571	315-0102-00			1 k $\Omega$	1/4 W	5%
R572	315-0563-00			56 k $\Omega$	1/4 W	5%
R573	315-0100-00			10 $\Omega$	1/4 W	5%
R574	315-0330-00			33 $\Omega$	1/4 W	5%
R575	307-0113-00			5.1 $\Omega$	1/4 W	5%
R576	315-0100-00			10 $\Omega$	1/4 W	5%
R577	315-0103-00			10 k $\Omega$	1/4 W	5%
R578	322-0085-00			75 $\Omega$	1/4 W	Prec 1%
R579	322-0085-00			75 $\Omega$	1/4 W	Prec 1%
R586	315-0272-00			2.7 k $\Omega$	1/4 W	5%
R587	315-0560-00			56 $\Omega$	1/4 W	5%
R588	315-0272-00			2.7 k $\Omega$	1/4 W	5%
R589	315-0560-00			56 $\Omega$	1/4 W	5%

Electrical Parts List—Type 141A/R141A

Resistors (cont)

Ckt. No.	Tektronix Part No.	Serial/Model No. Eff	Disc	Description		
R590	315-0272-00			2.7 kΩ	1/4 W	5%
R591	315-0560-00			56 Ω	1/4 W	5%
R601	315-0102-00			1 kΩ	1/4 W	5%
R602	315-0302-00			3 kΩ	1/4 W	5%
R603	321-0154-00			392 Ω	1/8 W	Prec 1%
R604	321-0154-00			392 Ω	1/8 W	Prec 1%
R605	315-0181-00			180 Ω	1/4 W	5%
R606	315-0181-00			180 Ω	1/4 W	5%
R607	315-0181-00			180 Ω	1/4 W	5%
R608	315-0181-00			180 Ω	1/4 W	5%
R612	321-0685-00			30 kΩ	1/8 W	Prec 1/2%
R613	321-0143-00			301 Ω	1/8 W	Prec 1%
R615	315-0302-00			3 kΩ	1/4 W	5%
R616	315-0102-00			1 kΩ	1/4 W	5%
R618	321-0735-07			1.001 kΩ	1/8 W	Prec 1/10%
R619	321-0159-00			442 Ω	1/8 W	Prec 1%
R622	321-0685-00			30 kΩ	1/8 W	Prec 1/2%
R623	321-0143-00			301 Ω	1/8 W	Prec 1%
R625	311-0886-00	B010100	B109999	50 Ω, Var		
R625	311-1258-00	B110000		50 Ω, Var		
R628	321-0735-07			1.001 kΩ	1/8 W	Prec 1/10%
R629	321-0122-00			182 Ω	1/8 W	Prec 1%
R630	315-0202-00			2 kΩ	1/4 W	5%
R634	321-0161-00	B010100	B039999	464 Ω	1/8 W	Prec 1%
R634	321-0812-07	B040000		455 Ω	1/8 W	Prec 1/10%
R636	321-0161-00	B010100	B039999	464 Ω	1/8 W	Prec 1%
R636	321-0812-07	B040000		455 Ω	1/8 W	Prec 1/10%
R640	315-0102-00			1 kΩ	1/4 W	5%
R642	315-0102-00			1 kΩ	1/4 W	5%
R644	315-0152-00			1.5 kΩ	1/4 W	5%
R651	315-0102-00			1 kΩ	1/4 W	5%
R652	315-0302-00			3 kΩ	1/4 W	5%
R653	321-0154-00			392 Ω	1/8 W	Prec 1%
R654	321-0154-00			392 Ω	1/8 W	Prec 1%
R655	315-0181-00			180 Ω	1/4 W	5%
R656	315-0181-00			180 Ω	1/4 W	5%
R657	315-0181-00			180 Ω	1/4 W	5%
R658	315-0181-00			180 Ω	1/4 W	5%
R662	321-0685-00			30 kΩ	1/8 W	Prec 1/2%
R663	321-0143-00			301 Ω	1/8 W	Prec 1%
R665	315-0302-00			3 kΩ	1/4 W	5%
R666	315-0102-00			1 kΩ	1/4 W	5%
R668	321-0735-07			1.001 kΩ	1/8 W	Prec 1/10%
R669	321-0159-00			442 Ω	1/8 W	Prec 1%
R672	321-0685-00			30 kΩ	1/8 W	Prec 1/2%
R673	321-0143-00			301 Ω	1/8 W	Prec 1%
R675	311-0886-00	B010100	B109999	50 Ω, Var		
R675	311-1258-00	B110000		50 Ω, Var		
R678	321-0735-07			1.001 kΩ	1/8 W	Prec 1/10%

## Resistors (cont)

Ckt. No.	Tektronix Part No.	Serial/Model No.		Description			
		Eff	Disc				
R783	321-0294-00	B100000		11.3 k $\Omega$	1/8 W	Prec	1%
R784	311-0836-00	B010100	B099999	5 k $\Omega$ , Var			
R784	311-0732-00	B100000	B109999	1 k $\Omega$ , Var			
R784	311-1263-00	B110000		1 k $\Omega$ , Var			
R785	321-0295-00	B010100	B099999	11.5 k $\Omega$	1/8 W	Prec	1%
R785	321-0300-00	B100000		13 k $\Omega$	1/8 W	Prec	1%
R786	311-0836-00	B010100	B099999	5 k $\Omega$ , Var			
R786	311-1016-00	B100000	B109999	2 k $\Omega$ , Var			
R786	311-1265-00	B110000		2 k $\Omega$ , Var			
R787	315-0101-00			100 $\Omega$	1/4 W		5%
R788	315-0101-00			100 $\Omega$	1/4 W		5%
R789	315-0101-00			100 $\Omega$	1/4 W		5%
R791	321-0344-00	B010100	B099999	37.4 k $\Omega$	1/8 W	Prec	1%
R791	321-0349-00	B100000		42.2 k $\Omega$	1/8 W	Prec	1%
R792	311-0950-00	B010100	B109999	10 k $\Omega$ , Var			
R792	311-1268-00	B110000		10 k $\Omega$ , Var			
R795	321-0344-00	B010100	B099999	37.4 k $\Omega$	1/8 W	Prec	1%
R795	321-0349-00	B100000		42.2 k $\Omega$	1/8 W	Prec	1%
R796	311-0950-00	B010100	B109999	10 k $\Omega$ , Var			
R796	311-1268-00	B110000		10 k $\Omega$ , Var			
R811	308-0245-00			0.6 $\Omega$	2 W	WW	5%
R813	315-0101-00			100 $\Omega$	1/4 W		5%
R816	315-0101-00			100 $\Omega$	1/4 W		5%
R826	315-0222-00			2.2 k $\Omega$	1/4 W		5%
R831	315-0222-00			2.2 k $\Omega$	1/4 W		5%
R835	321-0219-00			1.87 k $\Omega$	1/8 W	Prec	1%
R836	311-0827-00	B010100	B109999	250 $\Omega$ , Var			
R836	311-1260-00	B110000		250 $\Omega$ , Var			
R837	321-0237-00			2.87 k $\Omega$	1/8 W	Prec	1%
R841	308-0244-00			0.3 $\Omega$	2 W	WW	
R843	315-0101-00			100 $\Omega$	1/4 W		5%
R846	315-0222-00			2.2 k $\Omega$	1/4 W		5%
R848	315-0821-00			820 $\Omega$	1/4 W		5%
R850	315-0390-00			39 $\Omega$	1/4 W		5%
R852	315-0392-00			3.9 k $\Omega$	1/4 W		5%
R855	321-0171-00			590 $\Omega$	1/8 W	Prec	1%
R856	311-0827-00	B010100	B109999	250 $\Omega$ , Var			
R856	311-1260-00	B110000		250 $\Omega$ , Var			
R857	321-0237-00			2.87 k $\Omega$	1/8 W	Prec	1%
R861	307-0093-00			1.2 $\Omega$	1/2 W		5%
R864	315-0101-00			100 $\Omega$	1/4 W		5%
R870	315-0821-00			820 $\Omega$	1/4 W		5%
R871	315-0471-00			470 $\Omega$	1/4 W		5%
R872	315-0181-00			180 $\Omega$	1/4 W		5%
R875	315-0122-00			1.2 k $\Omega$	1/4 W		5%
R877	315-0621-00			620 $\Omega$	1/4 W		5%
R879	315-0101-00			100 $\Omega$	1/4 W		5%
R880	315-0150-00			15 $\Omega$	1/4 W		5%
R885	321-0215-00			1.69 k $\Omega$	1/8 W	Prec	1%
R886	311-0827-00	B010100	B109999	250 $\Omega$ , Var			
R886	311-1260-00	B110000		250 $\Omega$ , Var			
R887	321-0195-00			1.05 k $\Omega$	1/8 W	Prec	1%
R889	315-0332-00			3.3 k $\Omega$	1/4 W		5%
R900	315-0220-00			22 $\Omega$	1/4 W		5%
R901	321-0222-00			2 k $\Omega$	1/8 W	Prec	1%
R902	315-0101-00			100 $\Omega$	1/4 W		5%
R905	321-0117-00			162 $\Omega$	1/8 W	Prec	1%

Electrical Parts List—Type 141A/R141A

Resistors (cont)

Ckt. No.	Tektronix Part No.	Serial/Model No. Eff	Disc	Description		
R906	321-0260-00		4.99 kΩ	1/8 W	Prec	1%
R907	315-0103-00		10 kΩ	1/4 W		5%
R908	321-0275-00		7.15 kΩ	1/8 W	Prec	1%
R909	315-0432-00		4.3 kΩ	1/4 W		5%
R910	321-0222-00		2 kΩ	1/8 W	Prec	1%
R911	322-0085-00		75 Ω	1/4 W	Prec	1%
R912	315-0563-00		56 kΩ	1/4 W		5%
R913	315-0102-00		1 kΩ	1/4 W		5%
R914	315-0103-00		10 kΩ	1/4 W		5%
R916	315-0100-00		10 Ω	1/4 W		5%
R920	315-0220-00		22 Ω	1/4 W		5%
R921	321-0222-00		2 kΩ	1/8 W	Prec	1%
R922	315-0101-00		100 Ω	1/4 W		5%
R925	321-0117-00		162 Ω	1/8 W	Prec	1%
R926	321-0260-00		4.99 kΩ	1/8 W	Prec	1%
R927	315-0103-00		10 kΩ	1/4 W		5%
R928	321-0275-00		7.15 kΩ	1/8 W	Prec	1%
R929	315-0432-00		4.3 kΩ	1/4 W		5%
R930	321-0222-00		2 kΩ	1/8 W	Prec	1%
R931	322-0085-00		75 Ω	1/4 W	Prec	1%
R932	315-0563-00		56 kΩ	1/4 W		5%
R933	315-0102-00		1 kΩ	1/4 W		5%
R934	315-0103-00		10 kΩ	1/4 W		5%
R936	315-0100-00		10 Ω	1/4 W		5%
R940	315-0220-00		22 Ω	1/4 W		5%
R941	321-0222-00		2 kΩ	1/8 W	Prec	1%
R942	315-0101-00		100 Ω	1/4 W		5%
R944	301-0430-00		43 Ω	1/2 W		5%
R945	321-0117-00		162 Ω	1/8 W	Prec	1%
R946	321-0260-00		4.99 kΩ	1/8 W	Prec	1%
R947	315-0103-00		10 kΩ	1/4 W		5%
R948	321-0275-00		7.15 kΩ	1/8 W	Prec	1%
R949	315-0432-00		4.3 kΩ	1/4 W		5%
R950	321-0222-00		2 kΩ	1/8 W		1%
R951	322-0085-00		75 Ω	1/4 W	Prec	1%
R952	315-0563-00		56 kΩ	1/4 W		5%
R953	315-0102-00		1 kΩ	1/4 W		5%
R954	315-0103-00		10 kΩ	1/4 W		5%
R956	315-0100-00		10 Ω	1/4 W		5%
R960	315-0220-00		22 Ω	1/4 W		5%
R961	321-0234-00		2.67 kΩ	1/8 W	Prec	1%
R962	315-0101-00		100 Ω	1/4 W		5%
R963	321-0638-00		7.96 kΩ	1/8 W	Prec	1%
R964	321-0282-00		8.45 kΩ	1/8 W	Prec	1%
R965	321-0117-00		162 Ω	1/8 W	Prec	1%
R966	321-0260-00		4.99 kΩ	1/8 W	Prec	1%
R967	315-0103-00		10 kΩ	1/4 W		5%
R968	321-0275-00		7.15 kΩ	1/8 W	Prec	1%
R969	315-0202-00		2 kΩ	1/4 W		5%
R970	321-0222-00		2 kΩ	1/8 W	Prec	1%

Resistors (cont)

Ckt. No.	Tektronix Part No.	Serial/Model No. Eff	Disc	Description		
R971	322-0085-00		75 Ω	1/4 W	Prec	1%
R972	315-0563-00		56 kΩ	1/4 W		5%
R973	315-0102-00		1 kΩ	1/4 W		5%
R974	315-0103-00		10 kΩ	1/4 W		5%
R975	307-0113-00		5.1 Ω	1/4 W		5%
R976	315-0100-00		10 Ω	1/4 W		5%
R977	307-0113-00		5.1 Ω	1/4 W		5%
R978	322-0085-00		75 Ω	1/4 W	Prec	1%
R979	315-0100-00		10 Ω	1/4 W		5%
R980	315-0220-00		22 Ω	1/4 W		5%
R981	321-0222-00		2 kΩ	1/8 W	Prec	1%
R982	315-0101-00		100 Ω	1/4 W		5%
R983	321-0213-00		1.62 kΩ	1/8 W	Prec	1%
R984	315-0822-00		8.2 kΩ	1/4 W		5%
R985	321-0117-00		162 Ω	1/8 W	Prec	1%
R986	321-0260-00		4.99 kΩ	1/8 W	Prec	1%
R987	315-0103-00		10 kΩ	1/4 W		5%
R988	321-0275-00		7.15 kΩ	1/4 W	Prec	1%
R989	315-0202-00		2 kΩ	1/4 W		5%
R990	321-0222-00		2 kΩ	1/8 W	Prec	1%
R991	322-0085-00		75 Ω	1/4 W	Prec	1%
R992	315-0563-00		56 kΩ	1/4 W		5%
R993	315-0102-00		1 kΩ	1/4 W		5%
R994	315-0103-00		10 kΩ	1/4 W		5%
R995	307-0113-00		5.1 Ω	1/4 W		5%
R996	315-0100-00		10 Ω	1/4 W		5%
R997	307-0113-00		5.1 Ω	1/4 W		5%
R998	322-0085-00		75 Ω	1/4 W	Prec	1%
R999	315-0100-00		10 Ω	1/4 W		5%

Switches

Wired or Unwired

S1	260-0621-00	Lever	V AXIS PHASING
S2 <sup>3</sup>			
S3 <sup>3</sup>			
S4	260-0276-00	Toggle	
S5	260-1024-00	Rotary	VITS LINE SELECTOR
S6	260-0731-00	Lever	SUBCARRIER 25 Hz OFFSET
S8	260-0731-00	Lever	SYNC
S10	260-0195-01	Lever	FIELD
S15	260-0731-00	Lever	U
S16	260-0731-00	Lever	V
S17	260-0731-00	Lever	Y
S18	260-0731-00	Lever	WHITE REF
S20	260-0731-00	Lever	CHROMA
S21	260-0731-00	Lever	STEPS
S25	260-1025-00	Rotary	AVERAGE PICTURE LEVEL
S66	260-0137-00	Lever	MODE
S70	260-0731-00	Lever	BRUCH SEQ
S71	260-0731-00	Lever	U
S72	260-0731-00	Lever	V
S750	260-0621-00	Lever	AMPLITUDE

<sup>3</sup>See Mechanical Parts List. Line Voltage Selector Body.

Electrical Parts List—Type 141A/R141A

Thermal Cutout

Ckt. No.	Tektronix Part No.	Serial/Model No. Eff	Disc	Description
TK158 <sup>4</sup>				
<b>Transformers</b>				
T1	*120-0583-00	B010100	B039999	L. V. Power
T1	*120-0630-00	B040000		L. V. Power
T121	*120-0588-00			Toroid, 3 windings
T131	*120-0589-00			Toroid, 4 turns bifilar
T351	*120-0585-00			Toroid, 3 windings
T385	*120-0564-00			Toroid, 3 windings
T601	*120-0584-00			Toroid, 3-10 turn windings
T651	*120-0587-00			Toroid, 4-10 windings
T691	*120-0586-00	B010100	B039999	Toroid, 10 turn quadfilar
T691	*120-0524-00	B040000		Toroid, 12 turn quadfilar
<b>Test Points</b>				
TP110	*214-0579-00			Pin, test point
TP117	*214-0579-00			Pin, test point
TP131	*214-0579-00			Pin, test point
TP132	*214-0579-00			Pin, test point
TP212	*214-0579-00			Pin, test point
TP222	*214-0579-00			Pin, test point
TP224	*214-0579-00			Pin, test point
TP226	*214-0579-00			Pin, test point
TP228	*214-0579-00			Pin, test point
TP242	*214-0579-00			Pin, test point
TP244	*214-0579-00			Pin, test point
TP250	*214-0579-00			Pin, test point
TP254	*214-0579-00			Pin, test point
TP256	*214-0579-00			Pin, test point
TP258	*214-0579-00			Pin, test point
TP260	*214-0579-00			Pin, test point
TP262	*214-0579-00			Pin, test point
TP264	*214-0579-00			Pin, test point
TP268	*214-0579-00			Pin, test point
TP274	*214-0579-00			Pin, test point
TP278	*214-0579-00			Pin, test point
TP280	*214-0579-00			Pin, test point
TP282	*214-0579-00			Pin, test point
TP325	*214-0579-00			Pin, test point
TP330	*214-0579-00			Pin, test point
TP335	*214-0579-00			Pin, test point
TP355	*214-0579-00			Pin, test point
TP360	*214-0579-00			Pin, test point
TP366	*214-0579-00			Pin, test point
TP380	*214-0579-00			Pin, test point

<sup>4</sup>Furnished as a unit with Oven Assembly (\*205-0108-01).



## Test Points (cont)

Ckt. No.	Tektronix Part No.	Serial/Model No. Eff	Disc	Description
TP391	*214-0579-00			Pin, test point
TP393	*214-0579-00			Pin, test point
TP395	*214-0579-00			Pin, test point
TP397	*214-0579-00			Pin, test point
TP406	*214-0579-00			Pin, test point
TP410	*214-0579-00			Pin, test point
TP418	*214-0579-00			Pin, test point
TP420	*214-0579-00			Pin, test point
TP432	*214-0579-00			Pin, test point
TP436	*214-0579-00			Pin, test point
TP438	*214-0579-00			Pin, test point
TP439	*214-0579-00			Pin, test point
TP440	*214-0579-00			Pin, test point
TP445	*214-0579-00			Pin, test point
TP460	*214-0579-00			Pin, test point
TP490	*214-0579-00			Pin, test point
TP502	*214-0579-00			Pin, test point
TP508	*214-0579-00			Pin, test point
TP520	*214-0579-00			Pin, test point
TP522	*214-0579-00			Pin, test point
TP524	*214-0579-00			Pin, test point
TP526	*214-0579-00			Pin, test point
TP530	*214-0579-00			Pin, test point
TP532	*214-0579-00			Pin, test point
TP558	*214-0579-00			Pin, test point
TP603	*214-0579-00			Pin, test point
TP612	*214-0579-00			Pin, test point
TP622	*214-0579-00			Pin, test point
TP653	*214-0579-00			Pin, test point
TP662	*214-0579-00			Pin, test point
TP672	*214-0579-00			Pin, test point
TP716	*214-0579-00			Pin, test point
TP720	*214-0579-00			Pin, test point
TP726	*214-0579-00			Pin, test point
TP750	*214-0579-00			Pin, test point
TP826	*214-0579-00			Pin, test point
TP846	*214-0579-00			Pin, test point
TP870	*214-0579-00			Pin, test point
TP876	*214-0579-00			Pin, test point
TP905	*214-0579-00			Pin, test point
TP925	*214-0579-00			Pin, test point
TP945	*214-0579-00			Pin, test point
TP965	*214-0579-00			Pin, test point
TP985	*214-0579-00			Pin, test point

Electrical Parts List—Type 141A/R141A

Integrated Circuits

Ckt. No.	Tektronix Part No.	Serial/Model No. Eff	Disc	Description
U212 <sup>5</sup>	156-0012-00			
U214 <sup>5</sup>	156-0012-00			
U215 <sup>6</sup>	152-0011-00			
U216 <sup>5</sup>	152-0012-00			
U217 <sup>5</sup>	156-0011-00			
U218 <sup>5</sup>	156-0012-00			
U219 <sup>6</sup>	156-0011-00			
U220 <sup>5</sup>	156-0012-00			
U221 <sup>6</sup>	156-0011-00			
U222 <sup>5</sup>	156-0012-00			
U224 <sup>5</sup>	156-0012-00			
U226 <sup>5</sup>	156-0012-00			
U228 <sup>5</sup>	156-0012-00			
U229 <sup>7</sup>	156-0010-00			
U230 <sup>5</sup>	156-0012-00			
U240 <sup>6</sup>	156-0011-00			
U242 <sup>6</sup>	156-0011-00			
U244 <sup>6</sup>	156-0011-00			
U246 <sup>5</sup>	156-0012-00			
U248 <sup>6</sup>	156-0011-00			
U250 <sup>5</sup>	156-0012-00			
U252 <sup>5</sup>	156-0012-00			
U254 <sup>6</sup>	156-0011-00			
U256 <sup>6</sup>	156-0011-00			
U258 <sup>6</sup>	156-0011-00			
U260 <sup>6</sup>	156-0011-00			
U261 <sup>6</sup>	156-0011-00	XB130000		
U262 <sup>6</sup>	156-0011-00			
U264 <sup>6</sup>	156-0011-00			
U266 <sup>6</sup>	156-0011-00			
U268 <sup>6</sup>	156-0011-00			
U270 <sup>6</sup>	156-0011-00			
U272 <sup>6</sup>	156-0011-00			
U274 <sup>6</sup>	156-0011-00			
U276 <sup>6</sup>	156-0011-00			
U278 <sup>6</sup>	156-0011-00			
U280 <sup>6</sup>	156-0011-00			
U282 <sup>6</sup>	156-0011-00			
U380 <sup>6</sup>	156-0011-00			
U381 <sup>6</sup>	156-0011-00			
U382 <sup>6</sup>	156-0011-00			
U383 <sup>6</sup>	156-0011-00			
U390 <sup>5</sup>	156-0012-00			
U391 <sup>5</sup>	156-0012-00			
U392 <sup>5</sup>	156-0012-00			
U393 <sup>5</sup>	156-0012-00			

<sup>5</sup>Clocked J-K Flipflop. Replaceable by Fairchild  $\mu$ L923.

<sup>6</sup>Medium Power Dual 2-Input Gate. Replaceable by Fairchild  $\mu$ L914.

<sup>7</sup>Buffer-Inverter. Replaceable by Fairchild  $\mu$ L900.

## Integrated Circuits (cont)

Ckt. No.	Tektronix Part No.	Serial/Model No. Eff Disc	Description
U394 <sup>5</sup>	156-0012-00		
U395 <sup>5</sup>	156-0012-00		
U396 <sup>5</sup>	156-0012-00		
U397 <sup>5</sup>	156-0012-00		
U402 <sup>5</sup>	156-0012-00		
U404 <sup>6</sup>	156-0011-00		
U405 <sup>6</sup>	156-0011-00		
U406 <sup>5</sup>	156-0012-00		
U408 <sup>5</sup>	156-0012-00		
U410 <sup>6</sup>	156-0011-00		
U414 <sup>5</sup>	156-0012-00		
U415 <sup>6</sup>	156-0011-00		
U416 <sup>5</sup>	156-0012-00		
U418 <sup>6</sup>	156-0011-00		
U420 <sup>5</sup>	156-0012-00		
U422 <sup>6</sup>	156-0011-00		
U423 <sup>6</sup>	156-0011-00		
U424 <sup>5</sup>	156-0012-00		
U426 <sup>5</sup>	156-0012-00		
U428 <sup>6</sup>	156-0011-00		
U430 <sup>5</sup>	156-0012-00		
U432 <sup>6</sup>	156-0011-00		
U436 <sup>6</sup>	156-0011-00		
U438 <sup>6</sup>	156-0011-00		
U439 <sup>6</sup>	156-0011-00		
U440 <sup>6</sup>	156-0011-00		
U460 <sup>6</sup>	156-0011-00		
U470 <sup>6</sup>	156-0011-00		
U480 <sup>5</sup>	156-0012-00		
U483 <sup>6</sup>	156-0011-00		
U485 <sup>6</sup>	156-0011-00		
U490 <sup>6</sup>	156-0011-00		
U497 <sup>6</sup>	156-0011-00		
U501 <sup>6</sup>	156-0011-00		
U502 <sup>6</sup>	156-0011-00		
U504 <sup>5</sup>	156-0012-00		
U506 <sup>5</sup>	156-0012-00		
U508 <sup>6</sup>	156-0011-00		
U510 <sup>6</sup>	156-0011-00		
U512 <sup>6</sup>	156-0011-00		
U514 <sup>6</sup>	156-0011-00		
U515 <sup>6</sup>	156-0011-00		
U520 <sup>6</sup>	156-0011-00		
U522 <sup>6</sup>	156-0011-00		
U524 <sup>6</sup>	156-0011-00		

<sup>5</sup>Clocked J-K Flipflop. Replaceable by Fairchild  $\mu$ L923.

<sup>6</sup>Medium Power Dual 2-Input Gate. Replaceable by Fairchild  $\mu$ L914.

**Electrical Parts List—Type 141A/R141A****Integrated Circuits (cont)**

Ckt. No.	Tektronix Part No.	Serial/Model No. Eff	Disc	Description
U526 <sup>6</sup>	156-0011-00			
U528 <sup>6</sup>	156-0011-00			
U530 <sup>6</sup>	156-0011-00			
U532 <sup>6</sup>	156-0011-00			
U580 <sup>6</sup>	156-0011-00			
U582 <sup>6</sup>	156-0011-00			
U583 <sup>6</sup>	156-0011-00			
U586 <sup>7</sup>	156-0010-00			
U588 <sup>7</sup>	156-0010-00			
U590 <sup>7</sup>	156-0010-00			

**Crystals**

Y105	158-0043-00	4.43 MHz
Y392	158-0014-00	1000 kHz

<sup>6</sup>Medium Power Dual 2-Input Gate. Replaceable by Fairchild  $\mu$ L914.

<sup>7</sup>Buffer-Invertor. Replaceable by Fairchild  $\mu$ L900.

## FIGURE AND INDEX NUMBERS

Items in this section are referenced by figure and index numbers to the illustrations which appear either on the back of the diagrams or on pullout pages immediately following the diagrams of the instruction manual.

## INDENTATION SYSTEM

This mechanical parts list is indented to indicate item relationships. Following is an example of the indentation system used in the Description column.

*Assembly and/or Component*  
*Detail Part of Assembly and/or Component*  
*mounting hardware for Detail Part*  
*Parts of Detail Part*  
*mounting hardware for Parts of Detail Part*  
*mounting hardware for Assembly and/or Component*

Mounting hardware always appears in the same indentation as the item it mounts, while the detail parts are indented to the right. Indented items are part of, and included with, the next higher indentation.

**Mounting hardware must be purchased separately, unless otherwise specified.**

## PARTS ORDERING INFORMATION

Replacement parts are available from or through your local Tektronix, Inc. Field Office or representative.

Changes to Tektronix instruments are sometimes made to accommodate improved components as they become available, and to give you the benefit of the latest circuit improvements developed in our engineering department. It is therefore important, when ordering parts, to include the following information in your order: Part number, instrument type or number, serial or model number, and modification number if applicable.

If a part you have ordered has been replaced with a new or improved part, your local Tektronix, Inc. Field Office or representative will contact you concerning any change in part number.

Change information, if any, is located at the rear of this manual.

## ABBREVIATIONS AND SYMBOLS

For an explanation of the abbreviations and symbols used in this section, please refer to the page immediately preceding the Electrical Parts List in this instruction manual.

INDEX OF MECHANICAL PARTS LIST ILLUSTRATIONS

(Located behind diagrams)

FIG. 1 FRONT & CHASSIS

FIG. 2 REAR

FIG. 3 STANDARD ACCESSORIES

# SECTION 7

## MECHANICAL PARTS LIST

FIG. 1 FRONT &amp; CHASSIS

Fig. & Index No.	Tektronix Part No.	Serial/Model Eff	No. Disc	Q					Description	
				†	Y	1	2	3		4
1-1	333-1127-03			1						PANEL, front (TYPE 141A only)
-2	348-0048-00			4						FOOT, plastic, black (TYPE 141A only)
-3	124-0216-00			2						STRIP, trim plastic (TYPE 141A only)
	- - - - -			-						mounting hardware for each: (not included w/strip)
-4	212-0068-00			2						SCREW, 8-32 x 5/16 inch, THS (TYPE 141A only)
-5	333-1181-03	B010100	B109999	1						PANEL, front
	333-1127-03	B110000		1						PANEL, front
-6	386-1486-00			1						SUB-PANEL, front
-7	260-0276-00			1						SWITCH, toggle—ON OFF
	- - - - -			-						mounting hardware: (not included w/switch)
	210-0414-00			1						NUT, hex., 15/32-32 x 9/16 inch
	210-0021-00			1						LOCKWASHER, internal, 0.480 ID x 0.607 inch OD
-8	337-1155-00			1						SHIELD, switch
	210-0902-00			1						WASHER, flat, 0.470 ID x 21/32 inch OD
-9	210-0473-00			1						NUT, 12 sided, 15/32-32 x 0.634 inch
-10	366-0215-02			1						KNOB, charcoal—U (COLOUR BAR)
-11	260-0731-00			1						SWITCH, lever—U (COLOUR BAR)
	- - - - -			-						mounting hardware: (not included w/switch)
	220-0413-00			2						NUT, switch mounting
-12	366-0215-02			1						KNOB, charcoal—V (COLOUR BAR)
-13	260-0731-00			1						SWITCH, lever—V (COLOUR BAR)
	- - - - -			-						mounting hardware: (not included w/switch)
	220-0413-00			2						NUT, switch mounting
-14	366-0215-02			1						KNOB, charcoal—Y
-15	260-0731-00			1						SWITCH, lever—Y
	- - - - -			-						mounting hardware: (not included w/switch)
	220-0413-00			2						NUT, switch mounting
-16	366-0215-02			1						KNOB, charcoal—WHITE REF
-17	260-0731-00			1						SWITCH, lever—WHITE REF
	- - - - -			-						mounting hardware: (not included w/switch)
	220-0413-00			2						NUT, switch mounting
-18	366-0215-02			1						KNOB, charcoal—SETUP
-19	260-0621-00			1						SWITCH, lever—SETUP
	- - - - -			-						mounting hardware: (not included w/switch)
	220-0413-00			2						NUT, switch mounting

Mechanical Parts List—Type 141A/R141A

FIG. 1 FRONT & CHASSIS (cont)

Fig. & Index No.	Tektronix Part No.	Serial/Model Eff	No. Disc	Q					Description	
				t	1	2	3	4		5
1-20	366-0215-02			1						KNOB, charcoal—SUBCARRIER MOD
-21	260-0731-00			1						SWITCH, lever—SUBCARRIER MOD
	- - - - -			-						mounting hardware: (not included w/switch)
	220-0413-00			2						NUT, switch mounting
-22	366-0215-02			1						KNOB, charcoal—STEPS
-23	260-0731-00			1						SWITCH, lever—STEPS
	- - - - -			-						mounting hardware: (not included w/switch)
	220-0413-00			2						NUT, switch mounting
-24	366-0215-02			1						KNOB, charcoal—U (BURST)
-25	260-0731-00			1						SWITCH, lever—U (BURST)
	- - - - -			-						mounting hardware: (not included w/switch)
	220-0413-00			2						NUT, switch mounting
-26	366-0215-02			1						KNOB, charcoal—V (BURST)
-27	260-0731-00			1						SWITCH, lever—V (BURST)
	- - - - -			-						mounting hardware: (not included w/switch)
	220-0413-00			2						NUT, switch mounting
-28	366-0215-02			1						KNOB, charcoal—BRUCH SEQ
-29	260-0731-00			1						SWITCH, lever—BRUCH SEQ
	- - - - -			-						mounting hardware: (not included w/switch)
	220-0413-00			2						NUT, switch mounting
-30	366-0215-02			1						KNOB, charcoal—V AXIS PHASING
-31	260-0621-00			1						SWITCH, lever—V AXIS PHASING
	- - - - -			-						mounting hardware: (not included w/switch)
	220-0413-00			2						NUT, switch mounting
-32	366-0215-02			1						KNOB, charcoal—SUBCARRIER 25Hz OFFSET
-33	260-0731-00			1						SWITCH, lever—SUBCARRIER 25Hz OFFSET
	- - - - -			-						mounting hardware: (not included w/switch)
	220-0413-00			2						NUT, switch mounting
-34	366-0215-02			1						KNOB, charcoal—SYNC
-35	260-0731-00			1						SWITCH, lever—SYNC
	- - - - -			-						mounting hardware: (not included w/switch)
-36	220-0413-00			2						NUT, switch mounting
-37	260-0195-01			1						SWITCH, lever—COLOUR BAR
	- - - - -			-						mounting hardware: (not included w/switch)
	210-0414-00			1						NUT, hex., $1\frac{5}{32}$ -32 x $\frac{9}{16}$ inch
-38	210-0021-00			1						LOCKWASHER, internal, 0.480 ID x 0.670 inch OD
	210-0902-00			1						WASHER, flat, 0.470 ID x $2\frac{1}{32}$ inch OD
-39	210-0473-00			1						NUT, 12 sided, $1\frac{5}{32}$ -32 x 0.634 inch



FIG. 1 FRONT & CHASSIS (cont)

Fig. & Index No.	Tektronix Part No.	Serial/Model Eff	No. Disc	Q					Description	
				†	Y	1	2	3		4
1-40	260-0137-00			1						SWITCH, lever—FIELD
	- - - - -			-						mounting hardware: (not included w/switch)
-41	210-0021-00			1						LOCKWASHER, internal, 0.480 ID x 0.607 inch OD
	210-0902-00			1						WASHER, flat, 0.470 ID x 2 <sup>1</sup> / <sub>32</sub> inch OD
-42	210-0473-00			1						NUT, 12 sided, 1 <sup>5</sup> / <sub>32</sub> -32 x 0.634 inch
-43	366-0500-00			1						KNOB, charcoal—AVERAGE PICTURE LEVEL
	- - - - -			-						knob includes;
	213-0153-00			2						SCREW, set, 5-40 x 0.125 inch, HSS
-44	260-1025-00			1						SWITCH, unwired—AVERAGE PICTURE LEVEL
	- - - - -			-						mounting hardware: (not included w/switch)
	210-0978-00			1						WASHER, flat, 3 <sup>8</sup> / <sub>8</sub> ID x 1 <sup>1</sup> / <sub>2</sub> inch OD
-45	210-0590-00			1						NUT, hex., 3 <sup>8</sup> / <sub>8</sub> -32 x 7 <sup>1</sup> / <sub>16</sub> inch
-46	366-0500-00			1						KNOB, charcoal—LINE
	- - - - -			-						knob includes:
	213-0153-00			2						SCREW, set, 5-40 x 0.125 inch, HSS
-47	260-1024-00			1						SWITCH, unwired—LINE
	- - - - -			-						mounting hardware: (not included w/switch)
	210-0978-00			1						WASHER, flat 3 <sup>8</sup> / <sub>8</sub> ID x 1 <sup>1</sup> / <sub>2</sub> inch OD
-48	210-0590-00			1						NUT, hex., 3 <sup>8</sup> / <sub>8</sub> -32 x 7 <sup>1</sup> / <sub>16</sub> inch
-49	136-0164-00			1						SOCKET, light
	- - - - -			-						mounting hardware: (not included w/socket)
	210-0978-00			1						WASHER, flat, 3 <sup>8</sup> / <sub>8</sub> ID x 1 <sup>1</sup> / <sub>2</sub> inch OD
-50	220-0480-02			1						NUT, 12 sided, 0.377-32 x 0.438 inch
-51	136-0079-00			1						SOCKET ASSEMBLY, w/green jewel & hardware
-52	131-0126-00			5						CONNECTOR, coaxial, 1 contact, BNC, female, w/hardware
	- - - - -			-						mounting hardware for each: (not included w/connector)
-53	210-0241-00			1						LUG, terminal
-54	213-0216-00	B010100	B109999	4						THUMB SCREW, 10-32 x 0.625 inch
	213-0216-00	B110000		2						THUMBSCREW, 10-32 x 0.625 inch
-55	210-0894-00	B010100	B109999	4						WASHER, plastic, 0.190 ID x 7 <sup>1</sup> / <sub>16</sub> inch OD
	210-0894-00	B110000		2						WASHER, plastic, 0.190 ID x 7 <sup>1</sup> / <sub>16</sub> inch OD
-56	354-0025-00	B010100	B109999	4						RING, retaining
	354-0025-00	B110000		2						RING, retaining
	124-0270-00	XB110000		1						STRIP, trim, right
	124-0270-01	XB110000		1						STRIP, trim, left
-57	367-0102-00			2						HANDLE, carrying
	- - - - -			-						mounting hardware for each: (not included w/handle)
-58	212-0004-00			2						SCREW, 8-32 x 5 <sup>1</sup> / <sub>16</sub> inch, PHS
-59	407-0510-00			2						BRACKET, angle
	- - - - -			-						mounting hardware for each: (not included w/bracket)
-60	212-0004-00			2						SCREW, 8-32 x 5 <sup>1</sup> / <sub>16</sub> inch, PHS
-61	441-0824-00			1						CHASSIS, main
	- - - - -			-						mounting hardware: (not included w/chassis)
-62	210-0457-00			4						NUT, keps, 6-32 x 5 <sup>1</sup> / <sub>16</sub> inch

Mechanical Parts List—Type 141A/R141A

FIG. 1 FRONT & CHASSIS (cont)

Fig. & Index No.	Tektronix Part No.	Serial/Model Eff	No. Disc	Q					Description	
				t y	1	2	3	4		5
1-63	214-1169-00			12						PIN, guide
	- - - - -			-						mounting hardware for each: (not included w/pin)
-64	210-0457-00			1						NUT, keps, 6-32 x 5/16 inch
	-65	344-0133-00		36						CLIP, circuit board
	- - - - -			-						mounting hardware for each: (not included w/clip)
-66	213-0138-00			1						SCREW, sheet metal, #4 x 3/16 inch, PHS
	-67	348-0050-00		3						GROMMET, plastic, 3/4 inch diameter
	-68	343-0088-00		1						CLAMP, cable, plastic, small
	-69	343-0089-00		1						CLAMP, cable, plastic, large
	-70	344-0118-00		2						CLIP, capacitor mounting
	- - - - -			-						mounting hardware for each: (not included w/clip)
	-71	211-0504-00		1						SCREW, 6-32 x 1/4 inch, PHS
		210-0457-00		1						NUT, keps, 6-32 x 5/16 inch
	-72	210-0201-00		7						LUG, solder, SE #4
	- - - - -			-						mounting hardware for each: (not included w/lug)
-73	213-0044-00			1						SCREW, thread forming 5-32 x 3/16 inch, PHS
	-74	386-1532-00		1						SUPPORT, chassis
-75	670-0290-00			1						ASSEMBLY, circuit board—POWER SUPPLY
	- - - - -			-						assembly includes:
		388-1099-00		1						BOARD, circuit
-76	131-0633-00			36						TERMINAL, pin
-77	136-0183-00			3						SOCKET, transistor, 3 pin
-78	136-0220-00			10						SOCKET, transistor, 3 pin
-79	214-0579-00			4						PIN, test point
	- - - - -			-						mounting hardware: (not included w/assembly)
-80	211-0116-00			3						SCREW, sems, 4-40 x 5/16 inch, PHB
	-81	670-0292-01	B010100	1						ASSEMBLY, circuit board—BAR DRIVE & VIDEO OUT
		670-0292-02	B100000	1						ASSEMBLY, circuit board—BAR DRIVE & VIDEO OUT
	- - - - -			-						assembly includes:
		388-1101-01		1						BOARD, circuit
-82	131-0633-00			38						TERMINAL, pin
-83	136-0183-00			2						SOCKET, transistor, 3 pin
-84	136-0220-00			10						SOCKET, transistor, 3 pin
-85	136-0235-00			14						SOCKET, semiconductor, 6 pin
-86	214-0579-00			4						PIN, test point

FIG. 1 FRONT & CHASSIS (cont)

Fig. & Index No.	Tektronix Part No.	Serial/Model No.		Q † Y	Description
		Eff	Disc		
1-87	670-0293-00			1	ASSEMBLY, circuit board—U. V. MODULATOR
	- - - - -			-	assembly includes:
	388-1102-01			1	BOARD, circuit
-88	131-0633-00			22	TERMINAL, pin
-89	136-0220-00			18	SOCKET, transistor, 3 pin
-90	136-0235-00			2	SOCKET, semiconductor, 6 pin
-91	214-0506-00			3	PIN, connector
-92	214-0579-00			6	PIN, test point
-93	337-0950-00			2	SHIELD, electrical
-94	352-0134-00			3	HOLDER, toroid
-95	670-0294-01	B010100	B089999	1	ASSEMBLY, circuit board—STAIRCASE
	670-0294-02	B090000	B099999	1	ASSEMBLY, circuit board—STAIRCASE
	670-0294-03	B100000		1	ASSEMBLY, circuit board—STAIRCASE
	- - - - -			-	assembly includes:
	388-1103-01			1	BOARD, circuit
-96	131-0633-00			46	TERMINAL, pin
-97	136-0220-00			30	SOCKET, transistor, 3 pin
-98	136-0237-00			22	SOCKET, semiconductor, 8 pin
-99	214-0579-00			9	PIN, test point
-100	670-0295-01			1	ASSEMBLY, circuit board—HORIZONTAL TIMING
	- - - - -			-	assembly includes:
	388-1104-01			1	BOARD, circuit
-101	131-0633-00			42	TERMINAL, pin
-102	136-0220-00			18	SOCKET, transistor, 3 pin
-103	136-0237-00			29	SOCKET, semiconductor, 8 pin
-104	214-0579-00			12	PIN, test point
-105	670-0296-00			1	ASSEMBLY, circuit board—HORIZ COLOR LOCK
	- - - - -			-	assembly includes:
	388-1105-00			1	BOARD, circuit
-106	131-0633-00			20	TERMINAL, pin
-107	136-0220-00			26	SOCKET, transistor, 3 pin
-108	136-0234-00			2	RECEPTACLE, electrical
-109	136-0235-00			1	SOCKET, semiconductor, 6 pin
-110	136-0237-00			12	SOCKET, semiconductor, 8 pin
-111	214-0506-00			1	PIN, connector
-112	214-0579-00			11	PIN, test point
-113	352-0096-00			1	HOLDER, crystal
-114	352-0125-00			1	HOLDER, toroid
-115	670-0297-00	B010100	B129999	1	ASSEMBLY, circuit board—VERTICAL
	670-0297-01	B130000		1	ASSEMBLY, circuit board—VERTICAL
	- - - - -			-	assembly includes:
	388-1106-00			1	BOARD, circuit
-116	131-0633-00			36	TERMINAL, pin
-117	136-0237-00			37	SOCKET, semiconductor, 8 pin
-118	214-0579-00			19	PIN, test point

Mechanical Parts List—Type 141A/R141A

FIG. 1 FRONT & CHASSIS (cont)

Fig. & Index No.	Tektronix Part No.	Serial/Model No.		Q t y	Description
		Eff	Disc		
-119	670-0313-00 670-0313-01 ----- 388-1412-00	B010100 B100000	B099999	1 1 - 1	ASSEMBLY, circuit board—OUTPUT AMP ASSEMBLY, circuit board—OUTPUT AMP assembly includes: BOARD, circuit
-120	131-0633-00			23	TERMINAL, pin
-121	136-0220-00			33	SOCKET, transistor, 3 pin
-122	214-0579-00 ----- -----			9 - -	PIN, test point mounting hardware: (not included w/assembly)
-123	211-0116-00			4	SCREW, sems, 4-40 x 5/16 inch, PHB
-124	179-1408-00 ----- -----			1 - -	CABLE HARNESS, chassis cable harness includes:
-125	131-0371-00			175	CONNECTOR, terminal (for small wire)
-126	131-0677-00			10	CONNECTOR, terminal (for large wire)
-127	390-0065-00 ----- -----			1 - -	CABINET SIDE, right mounting hardware: (not included w/cabinet side)
-128	211-0538-00			14	SCREW, 6-32 x 5/16 inch, 100° csk, FHS
-129	210-0457-00			14	NUT, keps, 6-32 x 5/16 inch
-130	390-0066-00 ----- -----			1 - -	CABINET SIDE, left mounting hardware: (not included w/cabinet side)
-131	211-0538-00			14	SCREW, 6-32 x 5/16 inch, 100° csk, FHS
-132	210-0457-00			14	NUT, keps, 6-32 x 5/16 inch
-133	348-0048-00 351-0104-00 ----- -----	XB080000		4 1 - -	FOOT, plastic SLIDE, section (pair) mounting hardware for each: (not included w/slide)
-134	212-0507-00			2	SCREW, 10-32 x 3/8 inch, PHS
-135	220-0410-00			2	NUT, keps, 10-32 x 3/8 inch
-136	390-0063-00 ----- -----			1 - -	CABINET BOTTOM cabinet bottom includes:
-137	355-0135-00 355-0135-01	B010100 B100620	B100619	12 12	STUD, turnlock fastener, OHS STUD, turnlock fastener, OHS
-138	355-0134-01			2	STUD, turnlock fastener, FHS
-139	214-0389-00			14	FASTENER, retainer
-140	390-0064-00 ----- -----			1 - -	CABINET TOP cabinet top includes:
-141	355-0135-00 355-0135-01	B010100 B100620	B100619	12 12	STUD, turnlock fastener, OHS STUD, turnlock fastener, FHS
-142	355-0134-01			2	STUD, turnlock fastener, FHS
-143	214-0389-00			14	FASTENER, retainer

FIG. 2 REAR

Fig. & Index No.	Tektronix Part No.	Serial/Model No.		Q	Description
		Eff	Disc		
				t	
				y	1 2 3 4 5
2-1	407-0555-00			1	BRACKET, transformer
-2	348-0063-00			2	GROMMET, plastic, 1/2 inch diameter
-3	348-0050-00	B010100	B020229	5	GROMMET, plastic, 3/4 inch diameter
	348-0050-00	B020230		4	GROMMET, plastic, 3/4 inch diameter
	252-0564-00	B020230		1	CHANNEL, plastic, 3 3/4 inches
-4	- - - - -			1	TRANSFORMER
	- - - - -			-	mounting hardware: (not included w/transformer)
-5	212-0516-00			4	SCREW, 10-32 x 2 inches, HHS
	166-0227-00			4	TUBE, insulating (not shown)
-6	210-0812-00			4	WASHER, fiber, #10
-7	220-0410-00			4	NUT, keps, 10-32 x 3/8 inch
-8	407-0556-00			1	BRACKET, capacitor
	- - - - -			-	mounting hardware: (not included w/bracket)
-9	211-0507-00			4	SCREW, 6-32 x 5/16 inch, PHS
-10	210-0457-00			4	NUT, keps, 6-32 x 5/16 inch
-11	386-1487-00			1	SUPPORT, bracket
	- - - - -			-	mounting hardware: (not included w/support)
-12	211-0507-00			4	SCREW, 6-32 x 5/16 inch, PHS
-13	210-0457-00			4	NUT, keps, 6-32 x 5/16 inch
-14	200-0293-00			1	COVER, capacitor, plastic, 0.365 ID x 2 7/16 inches long
-15	200-0538-00			1	COVER, capacitor, plastic, 1.365 ID x 1.644 inches long
-16	- - - - -			2	CAPACITOR
	- - - - -			-	mounting hardware for each: (not included w/capacitor)
-17	211-0588-00			2	SCREW, 6-32 x 5/16 inch, HHS
-18	432-0048-00			1	BASE, capacitor mounting
-19	386-0254-00			1	PLATE, fiber, large
-20	210-0457-00			2	NUT, keps, 6-32 x 5/16 inch
-21	441-0823-00			1	CHASSIS
	- - - - -			-	mounting hardware: (not included w/chassis)
-22	211-0507-00			2	SCREW, 6-32 x 5/16 inch, PHS
-23	210-0457-00			2	NUT, keps, 6-32 x 5/16 inch
-24	344-0133-00			6	CLIP, circuit board
	- - - - -			-	mounting hardware for each: (not included w/clip)
-25	213-0138-00			1	SCREW, sheet metal, #4 x 3/16 inch, PHS

FIG. 2 REAR (cont)

Fig. & Index No.	Tektronix Part No.	Serial/Model No.		Q † y	Description
		Eff	Disc		
2-	119-0191-00			1	ASSEMBLY, oven
	- - - - -			-	assembly includes:
-26	200-0906-00			1	COVER ASSEMBLY, oven
-27	214-1097-00			1	INSULATOR, oven, thermal
-28	200-0905-00			1	COVER, oven, inner
-29	348-0179-00			1	PAD, cushioning
-30	670-0291-00	B010100	B049999	1	ASSEMBLY, circuit board—SUBCARRIER OSC
	670-0291-01	B050000		1	ASSEMBLY, circuit board—SUBCARRIER OSC
	- - - - -			-	assembly includes:
	388-1100-00	B010100	B049999	1	BOARD, circuit
	38-1100-01	B050000		1	BOARD, circuit
-31	131-0633-00			3	TERMINAL, pin
-32	136-0234-00			2	RECEPTACLE, electrical
-33	136-0252-01			12	SOCKET, pin connecting
-34	205-0108-01			1	SHELL, oven
-35	214-1096-00			1	INSULATOR, oven, thermal
-36	670-0289-00			1	ASSEMBLY, circuit board—SUBCARRIER OUTPUT
	- - - - -			-	assembly includes:
	388-1098-00			1	BOARD, circuit
-37	131-0633-00			15	TERMINAL, pin
-38	136-0220-00			3	SOCKET, transistor, 3 pin
-39	136-0235-00			2	SOCKET, semiconductor, 6 pin
-40	214-0506-00			1	PIN, connector
-41	214-0579-00			4	PIN, test point
-42	352-0134-00			1	HOLDER, toroid
-43	210-0589-00	B010100	B030304	2	NUT, locking 4-40 x 1/4 inch
	210-0586-00	B030305		2	NUT, keps, 4-40 x 1/4 inch
	- - - - -			-	mounting hardware: (not included w/assembly)
-44	211-0116-00			2	SCREW, sems, 6-32 x 5/16 inch, PHB
-45	179-1409-00			1	CABLE HARNESS, power
	- - - - -			-	cable harness includes:
-46	131-0371-00			20	CONNECTOR, terminal
-47	179-1399-00			1	CABLE HARNESS, line voltage selector
	- - - - -			-	cable harness includes:
-48	214-0768-00			8	CONTACT, electrical
-49	131-0126-00			8	CONNECTOR, coaxial, 1 contact, BNC, female, w/hardware
	- - - - -			-	mounting hardware for each: (not included w/connector)
-50	210-0241-00			1	LUG, terminal
-51	131-0126-00			4	CONNECTOR, coaxial, 1 contact, BNC, female, w/hardware
-52	- - - - -			2	TRANSISTOR
	- - - - -			-	mounting hardware for each: (not included w/transistor)
-53	211-0510-00			2	SCREW, 6-32 x 3/8 inch, PHS
-54	386-0978-00			1	PLATE, insulating, mica
-55	210-0935-00			2	WASHER, plastic, shouldered, #6
	210-0803-00			2	WASHER, flat, 0.150 ID x 3/8 inch OD
	210-0202-00			1	LUG, solder SE #6
-56	210-0457-00			2	NUT, keps, 6-32 x 3/8 inch

FIG. 2 REAR (cont)

Fig. & Index No.	Tektronix Part No.	Serial/Model No.		Q	Description
		Eff	Disc		
				t	
				y	1 2 3 4 5
2-57	- - - - -			1	TRANSISTOR
	- - - - -			-	mounting hardware: (not included w/transistor)
-58	211-0510-00			2	SCREW, 6-32 x 3/8 inch, PHS
-59	386-0143-00			1	PLATE, insulating, mica
-60	210-0975-00			2	WASHER, plastic, shouldered, #6
	210-0804-00			2	WASHER, flat, 0.170 ID x 3/8 inch OD
	210-0202-00			1	LUG, solder, SE #6
-61	210-0457-00			2	NUT, keps, 6-32 x 5/16 inch
-62	200-0918-00	B010100	B029999	1	COVER, transistor
	200-0918-01	B030000		1	COVER, transistor
	- - - - -			-	mounting hardware: (not included w/cover)
-63	211-0008-00			4	SCREW, 4-40 x 1/4 inch, PHS
-64	386-1488-01	B010100	B039999	1	PANEL, rear
	386-1488-02	B040000		1	PANEL, rear
-65	131-0171-00			1	CONNECTOR, 3 wire motor base
	- - - - -			-	mounting hardware: (not included w/connector)
-66	211-0507-00			2	SCREW, 6-32 x 5/16 inch, PHS
	210-0202-00			2	LUG, solder, SE #6 (not shown)
-67	210-0457-00			2	NUT, keps, 6-32 x 5/16 inch
-68	204-0279-00			1	BODY, line voltage selector
	- - - - -			-	mounting hardware: (not included w/body)
	210-0006-00			2	LOCKWASHER, internal, #6
-69	210-0407-00			2	NUT, hex., 6-32 x 1/4 inch
-70	200-0762-00			1	COVER, line voltage selector
	- - - - -			-	cover includes:
-71	352-0102-00			2	HOLDER, fuse
	- - - - -			-	mounting hardware for each: (not included w/holder)
-72	213-0088-00			2	SCREW, thread forming, #4 x 1/4 inch, PHS





# SECTION 8 DIAGRAMS

The following special symbols are used on the diagrams:



Screwdriver adjustment



Front or rear-panel control or connector.



Refers to the indicated diagram.

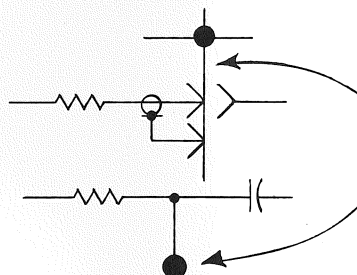

Connection soldered to circuit board.

Blue line encloses components located on circuit board.

Test point.

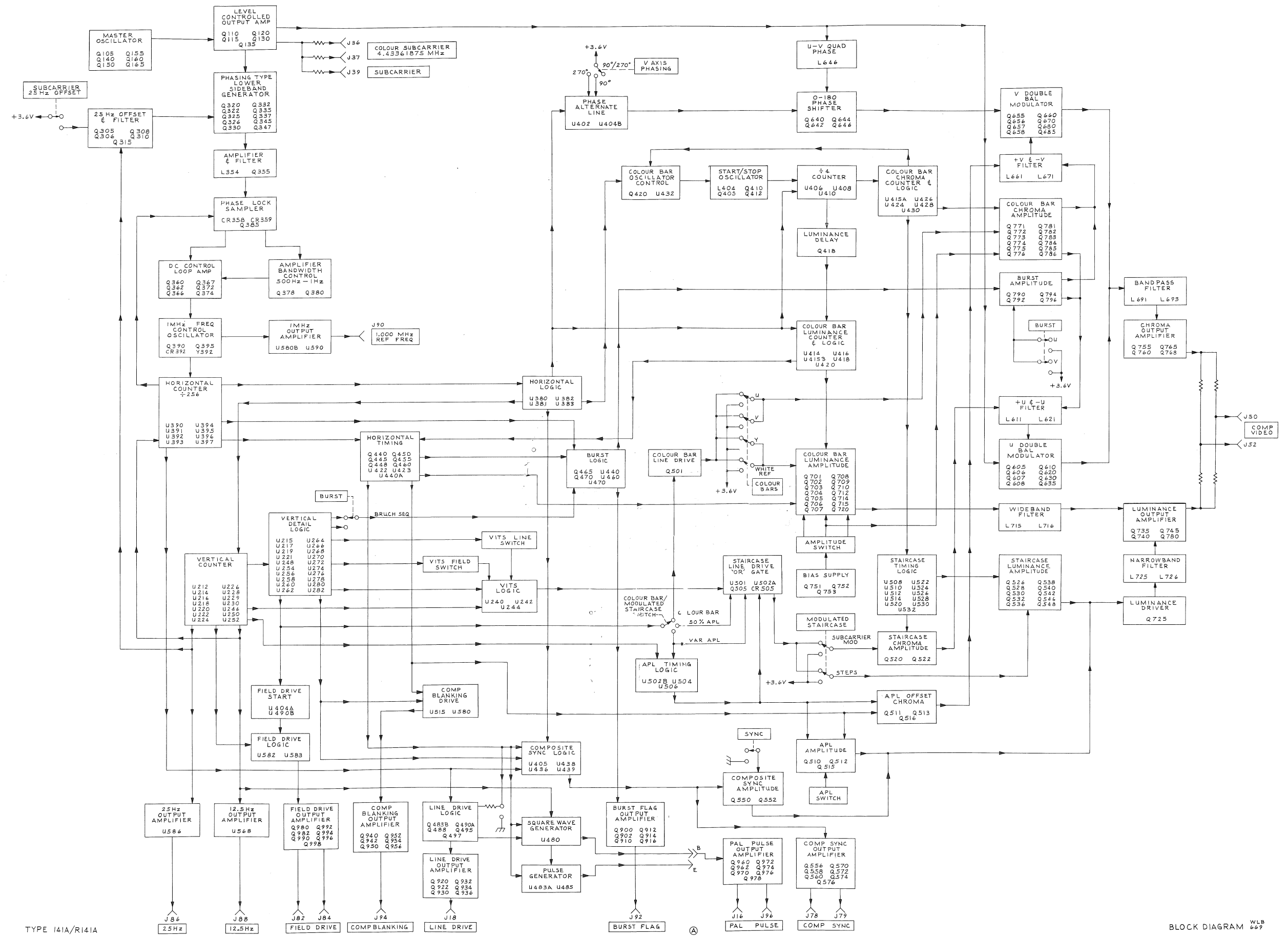

TYPE 141A/R141A

BLOCK DIAGRAM WLB 669

BLOCK DIAG

## VOLTAGE AND WAVEFORM CONDITIONS

DC circuit voltages measured with a digital multimeter with an accuracy of 0.1%; input impedance is greater than 1 kM $\Omega$  on the 1.500 volt range and 10 M $\Omega$  on the higher ranges. AC voltages measured with a VOM having an accuracy of 3%. All voltages were measured with respect to chassis ground unless noted otherwise.

Waveforms shown are actual photographs taken with a Tektronix Oscilloscope Camera System and Projected Graticule. Each major division represents one cm. Test oscilloscope deflection factor and sweep rate conditions are noted adjacent to each waveform. DC coupling was used to obtain the DC levels that are recorded at the right side of each waveform. These DC levels are located with respect to the graticule line rather than to the waveform. To show time related waveforms, the triggering source for the test oscilloscope is indicated on each diagram.

Voltages and Waveforms on the diagrams (shown in blue) are not absolute and may vary between instruments because of differing component tolerances and internal calibration.

The test oscilloscope used for obtaining the waveform photographs had the following minimum characteristics: Deflection factor, 1 mV/cm to 1 V/cm (10 mV/cm to 10 V/cm with a 10X probe); frequency response, DC to 10 MHz; sweep rates, 0.1  $\mu$ s/cm to 10 ms/cm.

### WARNING

"Ground lugs" are not always at ground potential. Check the schematic before using such connections as a ground for the multimeter, VOM or oscilloscope probe.

Type R141A control settings are as follows:

COLOUR BAR switches	All up
MODULATED STAIRCASE switches	All up
BURST switches	All up
V AXIS PHASING	90°/270°
25 Hz OFFSET	Up
SYNC	Up
FULL FIELD	
COLOUR BAR/MODULATED STAIRCASE	COLOUR BAR*
AVERAGE PICTURE LEVEL	12.5
VERTICAL INSERTION TEST SIGNAL	
LINE	11/324
FIELD	BOTH
POWER	ON
Line Voltage	Design Center (115 VAC) to obtain Power Supply voltage readings.

\*VAR APL was used for all voltages and waveforms on diagram

5

VOLTAGE & WAVEFORM CONDITIONS

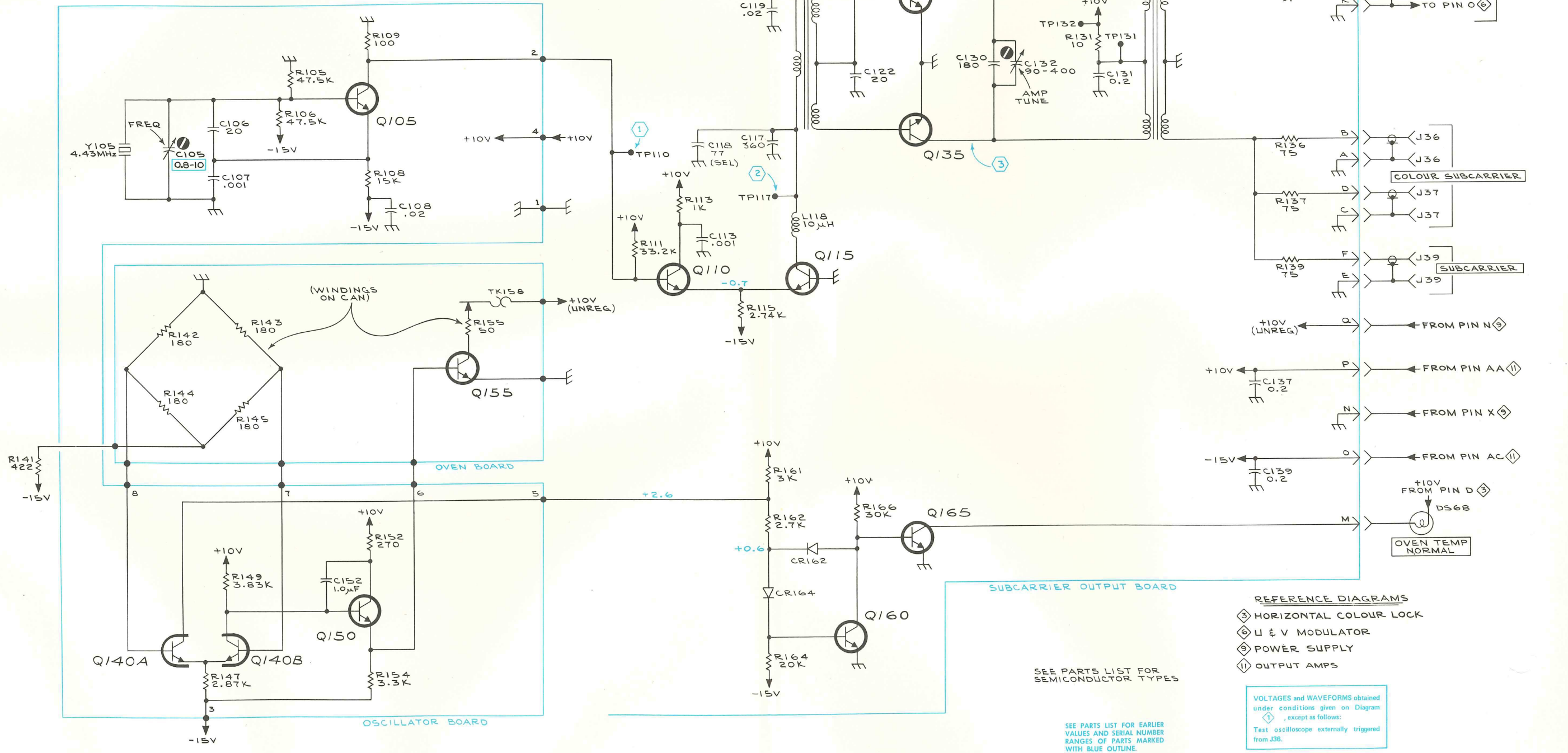
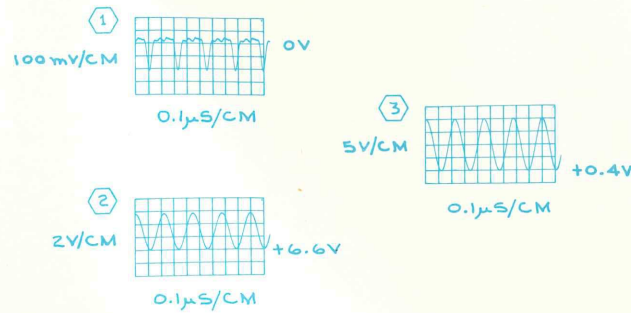

TYPE 141A/R141A

PLM 0670  
SUBCARRIER OSCILLATOR & OUTPUT

SUBCARRIER OSCILLATOR & OUTPUT

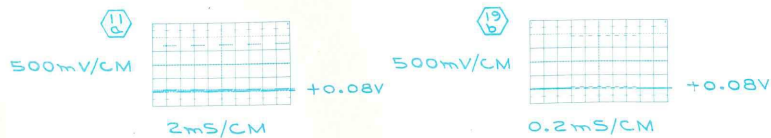
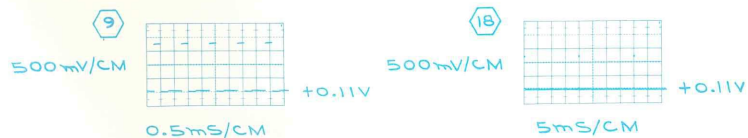
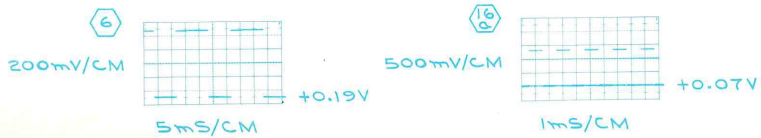
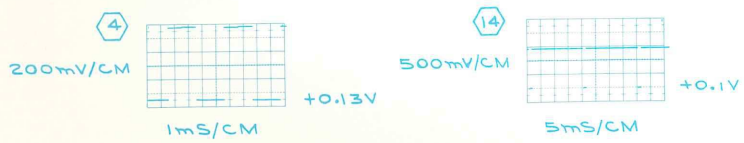
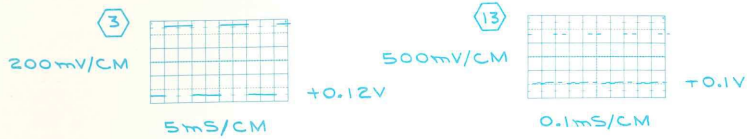



WIRING DIAGRAM FOR U244, U256, U258, U260, U266 & U270. U278 IS WIRED THE SAME, EXCEPT PINS 2 & 5 ARE ALSO INPUTS.

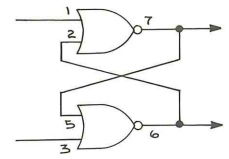

THE OUTPUT MAY BE PIN 6, PIN 7 OR BOTH. THE INPUTS ARE PIN 1 OR 2 & PIN 3 OR 5.

← WAVEFORMS

S5  
VITS LINE  
3R 3F 2F&R 1F&R

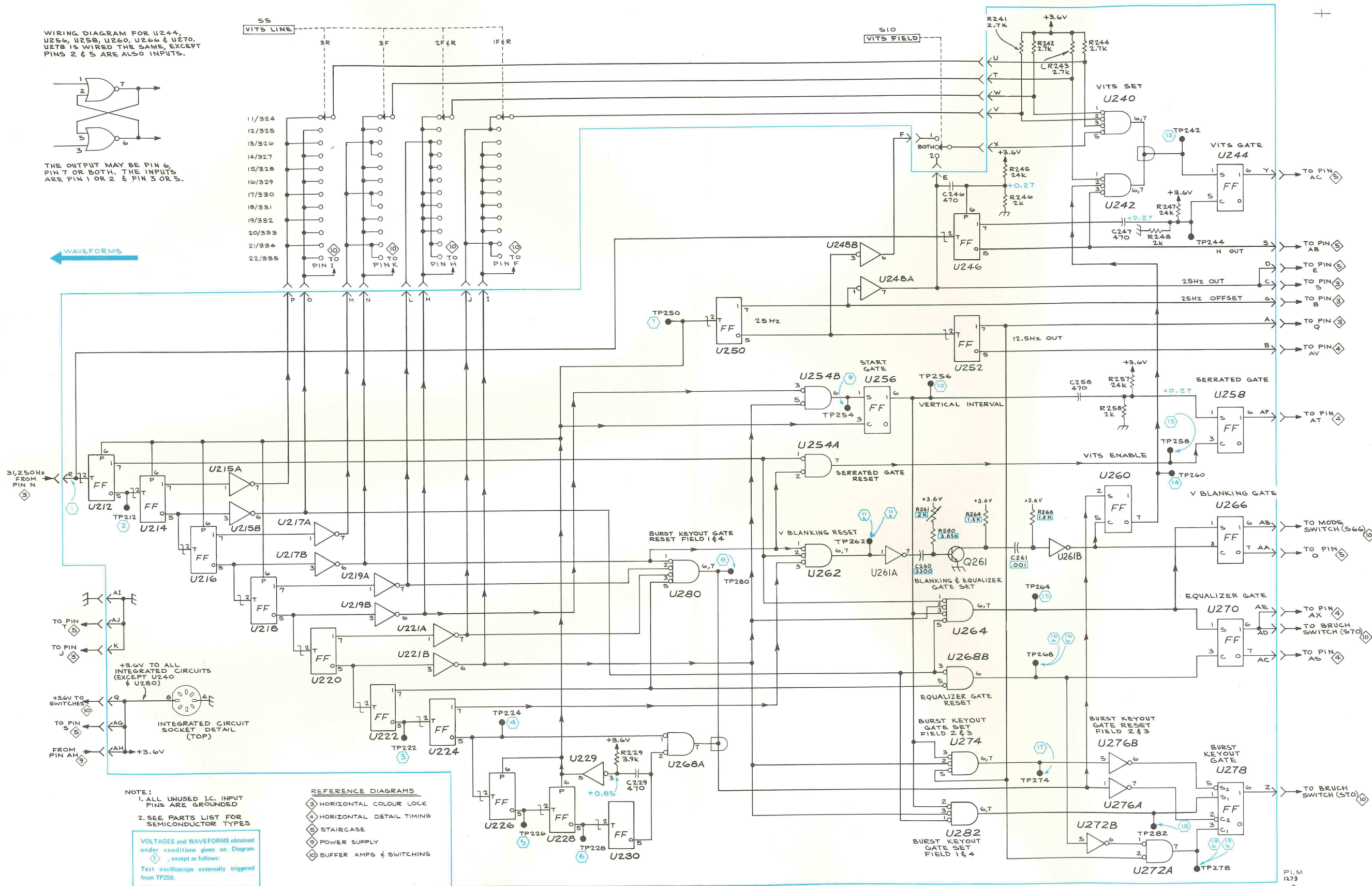
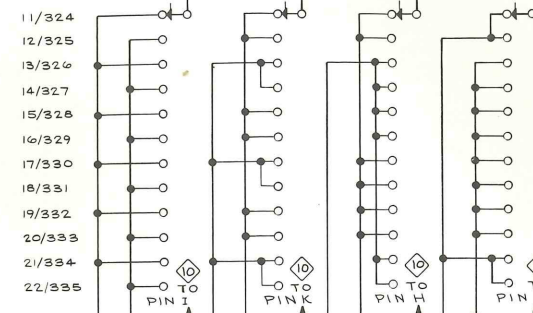

NOTE:  
1. ALL UNUSED I.C. INPUT PINS ARE GROUND  
2. SEE PARTS LIST FOR SEMICONDUCTOR TYPES

VOLTAGES and WAVEFORMS obtained under conditions given on Diagram, except as follows:  
① Test oscilloscope externally triggered from TP250.

REFERENCE DIAGRAMS  
③ HORIZONTAL COLOUR LOCK  
④ HORIZONTAL DETAIL TIMING  
⑤ STAIRCASE  
⑥ POWER SUPPLY  
⑦ BUFFER AMPS & SWITCHING

TYPE 141A/R141A

SEE PARTS LIST FOR VALUES, BRANDS AND SERIAL NUMBERS. SYMBOLS OF PARTS SHOWN WITH BLUE OUTLINE.

VERTICAL BOARD

VERTICAL ②

VERTICAL ②

PLM 1273

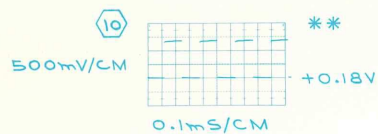
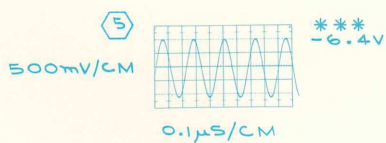
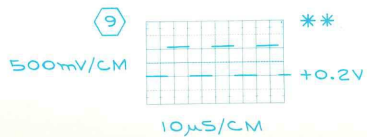
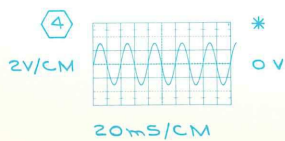
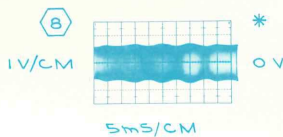
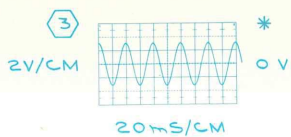
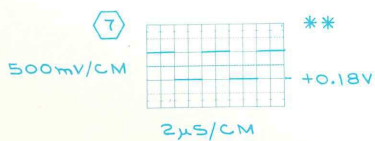
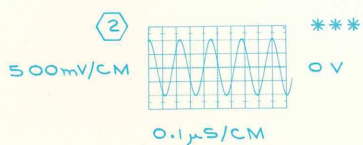
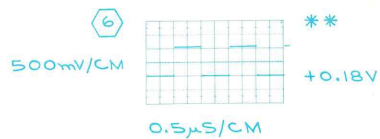
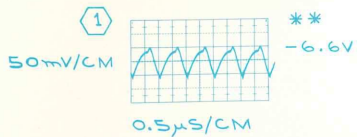



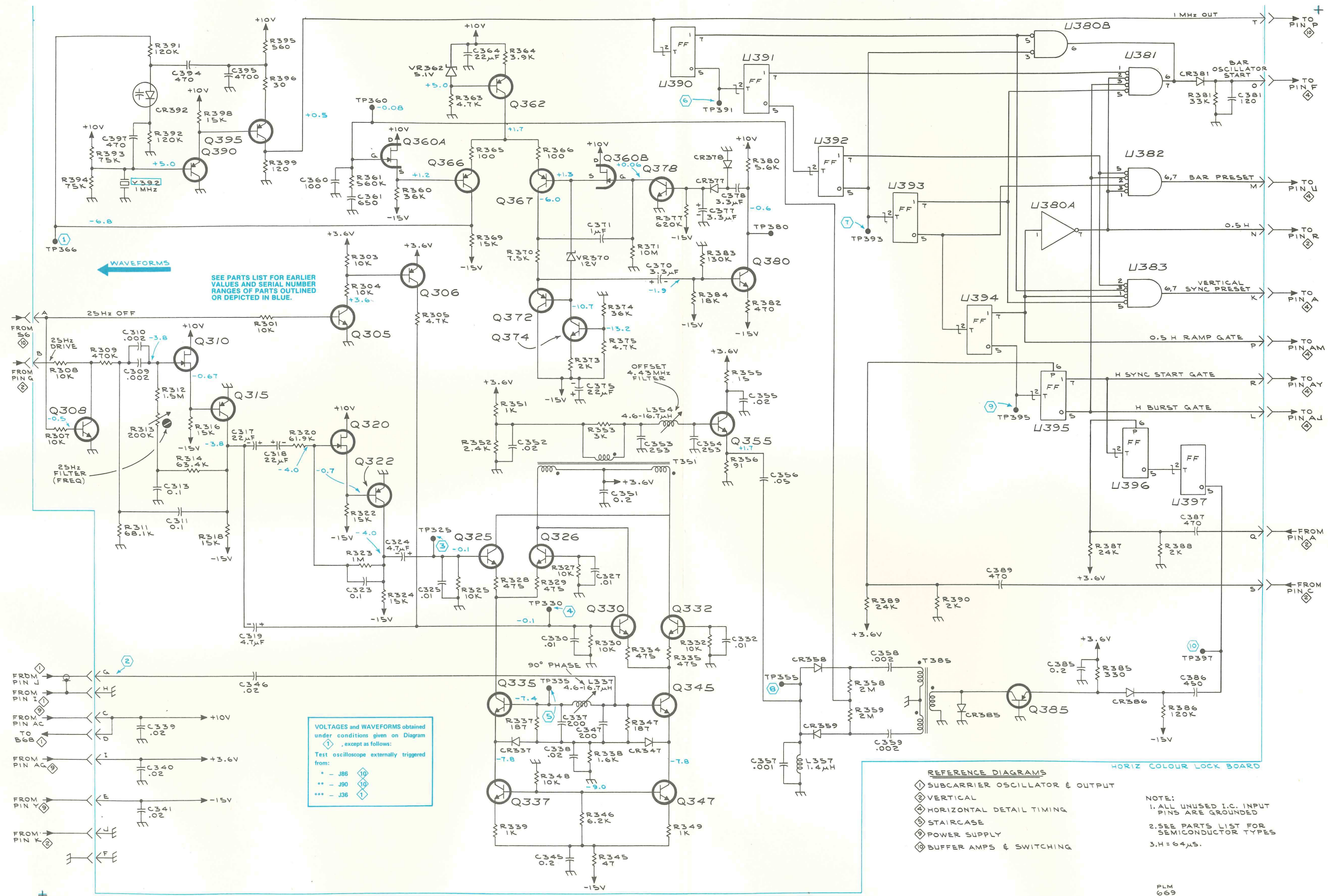

TYPE 141A/R141A

REV. B, OCT. 1977

HORIZONTAL COLOUR LOCK

HORIZONTAL COLOUR LOCK



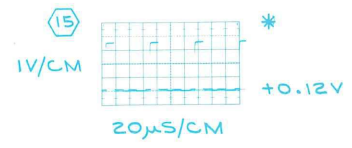
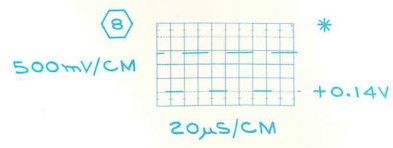
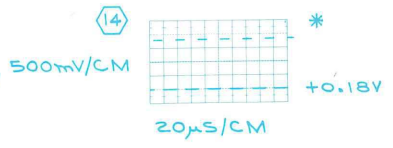
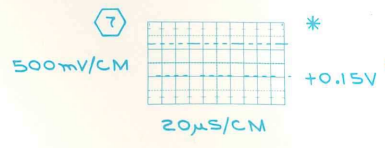
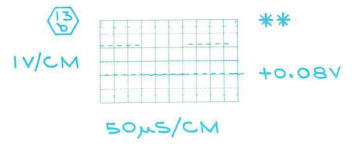
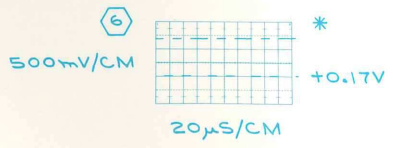
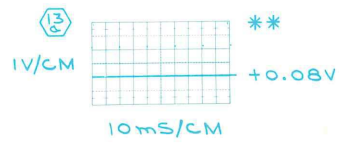
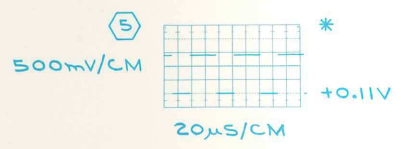
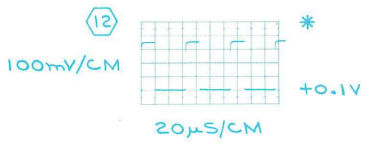
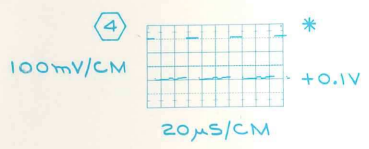
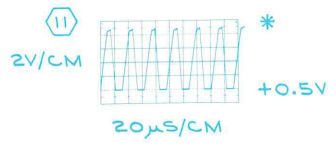
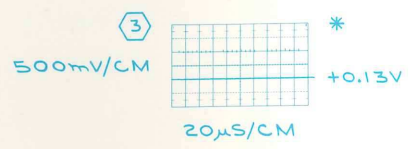
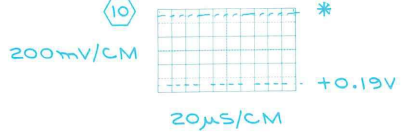
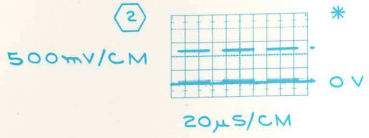
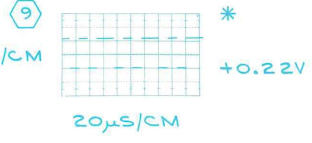
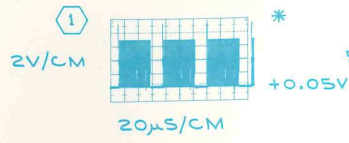

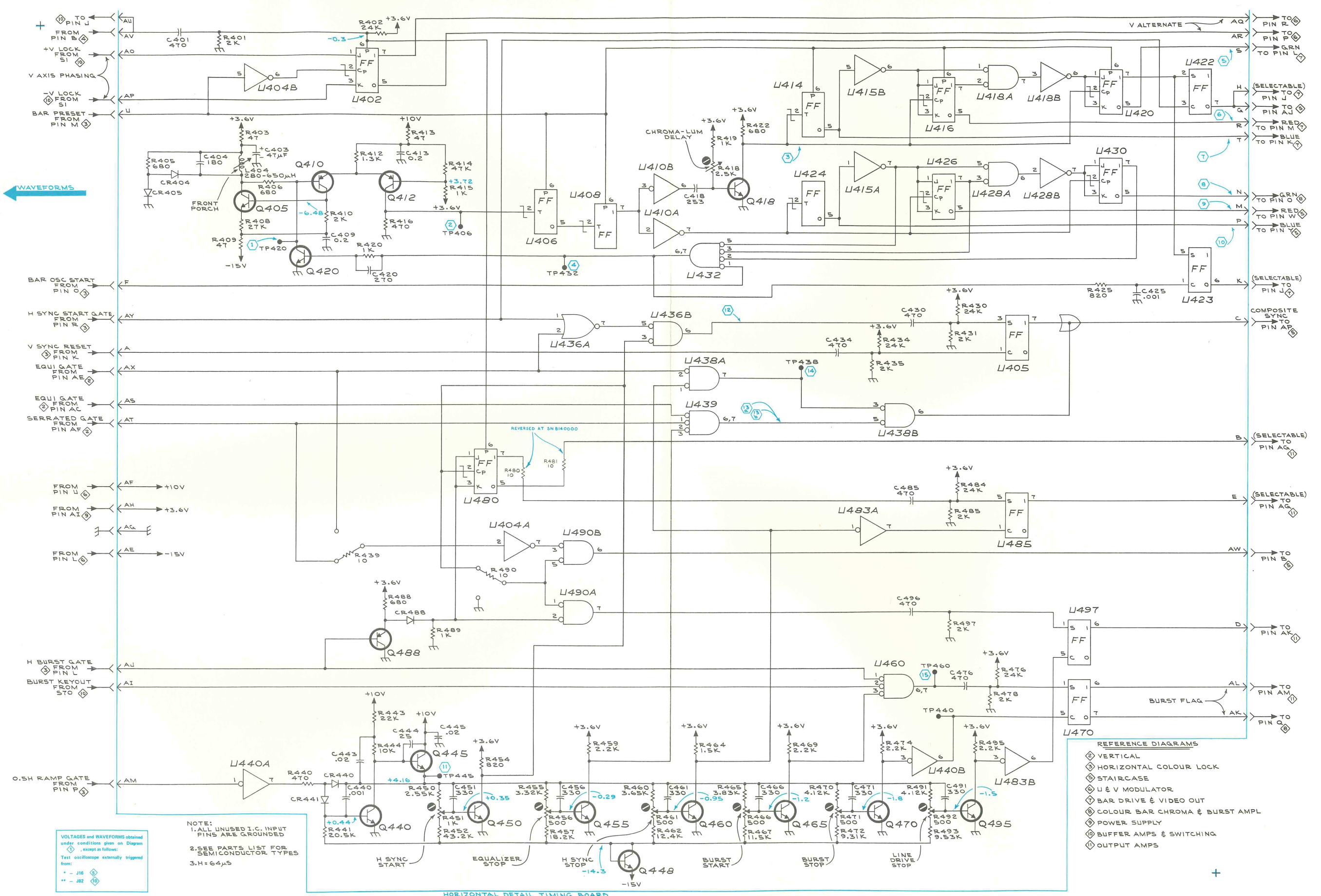

VOLTAGES and WAVEFORMS obtained under conditions given on Diagram except as follows:  
 Test oscilloscope externally triggered from:  
 - - J16  
 - - J82

NOTE:  
 1. ALL UNUSED I.C. INPUT PINS ARE GROUNDED  
 2. SEE PARTS LIST FOR SEMICONDUCTOR TYPES  
 3. H = 64µS

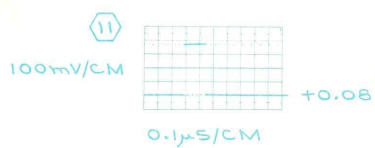
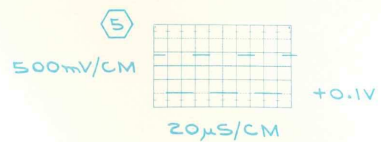
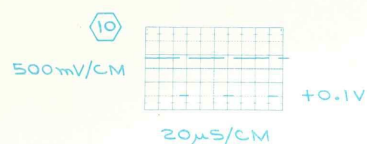
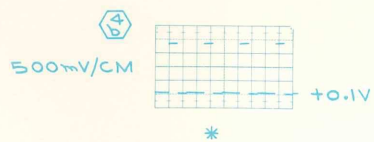
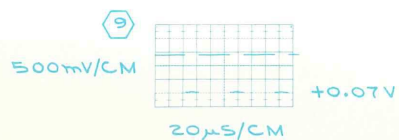
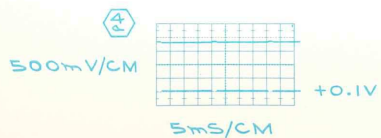
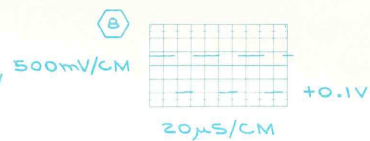
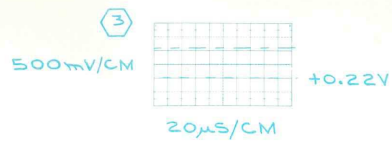
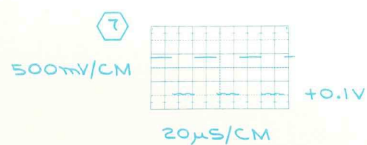
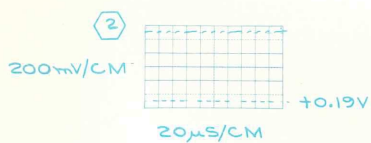
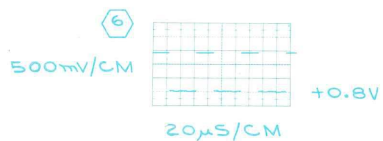
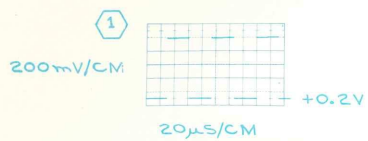



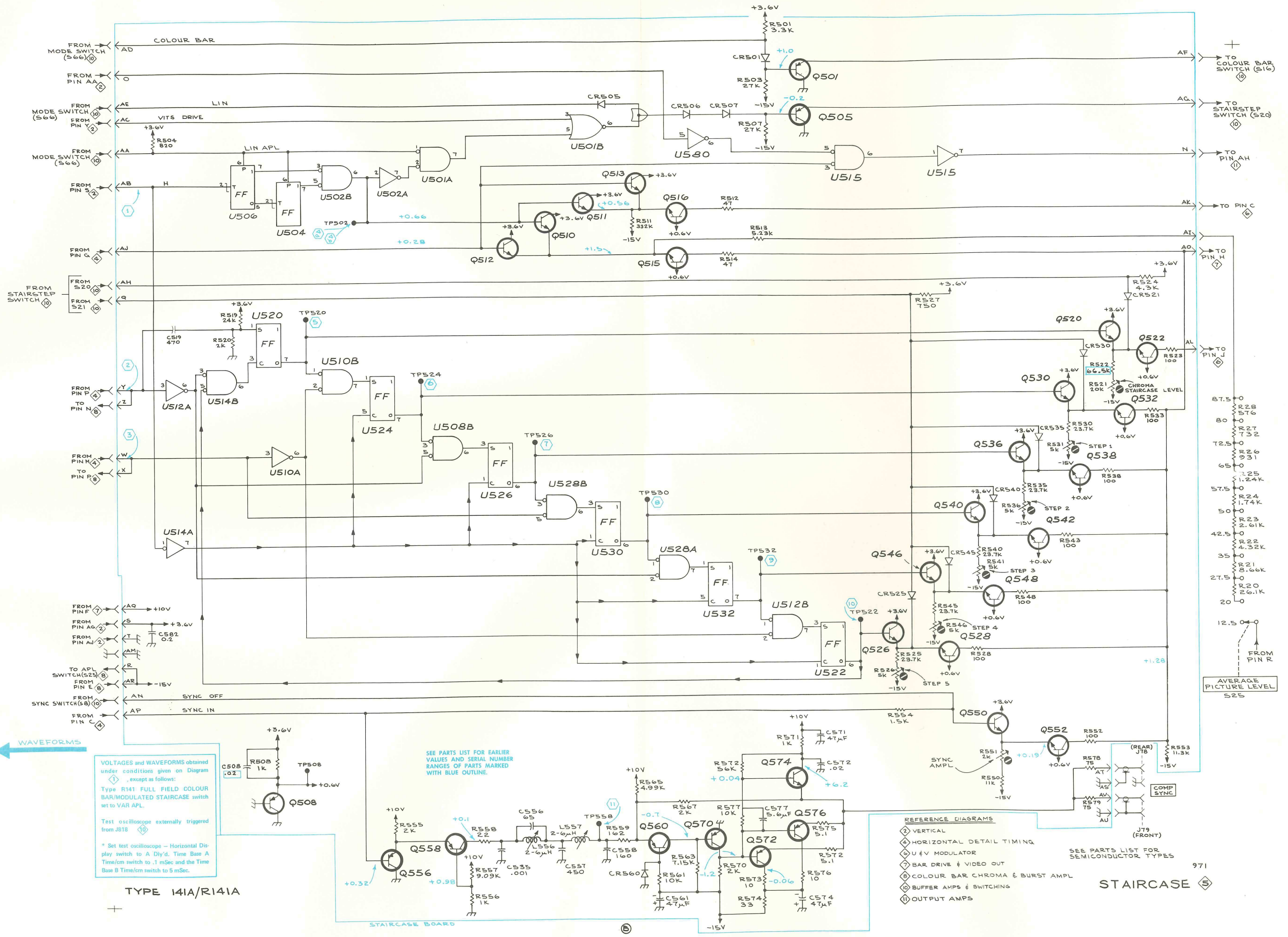

VOLTAGES and WAVEFORMS obtained under conditions given on Diagram, except as follows:  
 Type R141 FULL FIELD COLOUR BAR/MODULATED STAIRCASE switch set to VAR APL.  
 Test oscilloscope externally triggered from JB18.  
 \* Set test oscilloscope - Horizontal Display switch to A Div'd, Time Base A Time/cm switch to .1 mSec and the Time Base B Time/cm switch to 5 mSec.

SEE PARTS LIST FOR EARLIER VALUES AND SERIAL NUMBER RANGES OF PARTS MARKED WITH BLUE OUTLINE.

- REFERENCE DIAGRAMS
- ⬆ VERTICAL
  - ⬇ HORIZONTAL
  - ⊕ V MODULATOR
  - ⬆ BAR DRIVE & VIDEO OUT
  - ⊕ COLOUR BAR CHROMA & BURST AMPL
  - ⊕ BUFFER AMPS & SWITCHING
  - ⊕ OUTPUT AMPS

SEE PARTS LIST FOR SEMICONDUCTOR TYPES

STAIRCASE 971

TYPE 141A/R141A

STAIRCASE BOARD

Ⓢ

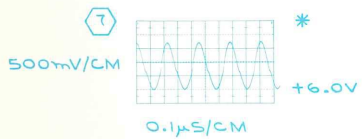
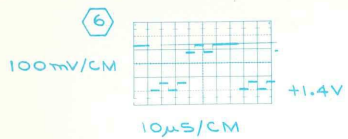
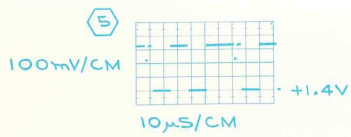
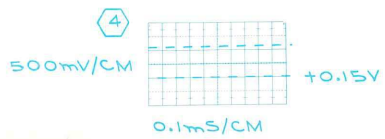
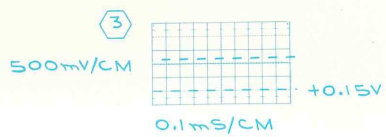
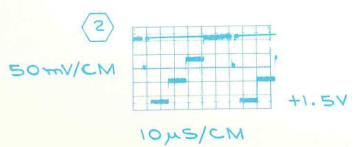
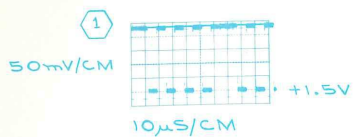



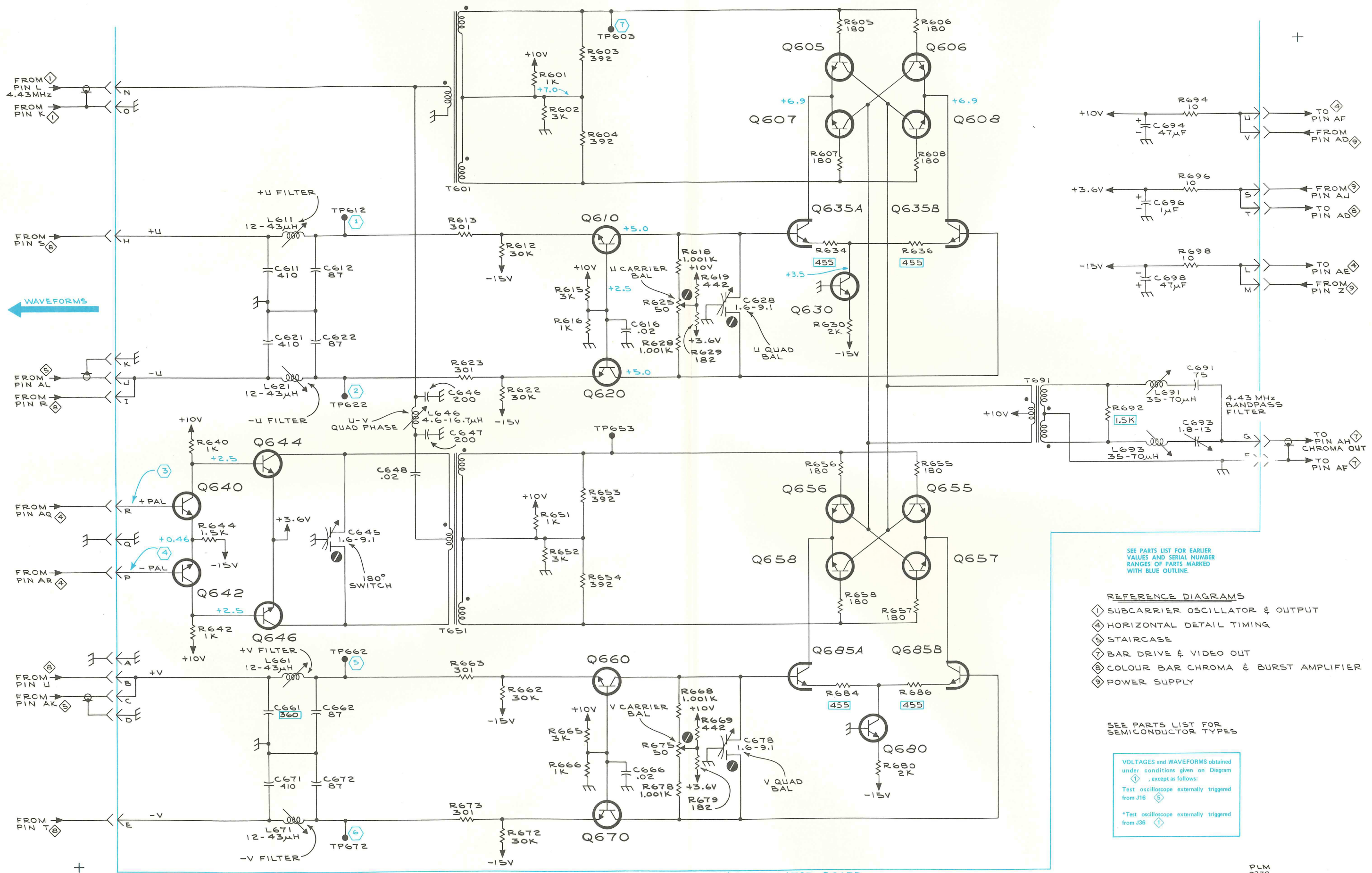

TYPE 141A/R141A

U & V MODULATOR BOARD

U & V MODULATOR

SEE PARTS LIST FOR EARLIER VALUES AND SERIAL NUMBER RANGES OF PARTS MARKED WITH BLUE OUTLINE.

REFERENCE DIAGRAMS

- ① SUBCARRIER OSCILLATOR & OUTPUT
- ② HORIZONTAL DETAIL TIMING
- ③ STAIRCASE
- ④ BAR DRIVE & VIDEO OUT
- ⑤ COLOUR BAR CHROMA & BURST AMPLIFIER
- ⑥ POWER SUPPLY

SEE PARTS LIST FOR SEMICONDUCTOR TYPES

VOLTAGES and WAVEFORMS obtained under conditions given on Diagram, except as follows:  
 Test oscilloscope externally triggered from J16 ⑤  
 \*Test oscilloscope externally triggered from J36 ①

U & V MODULATOR

⑥

PLM 0370

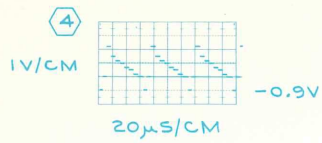
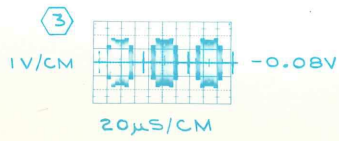
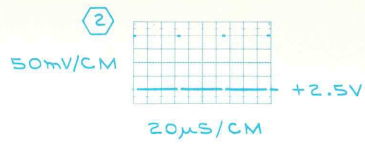
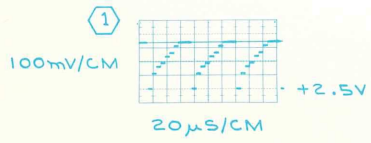

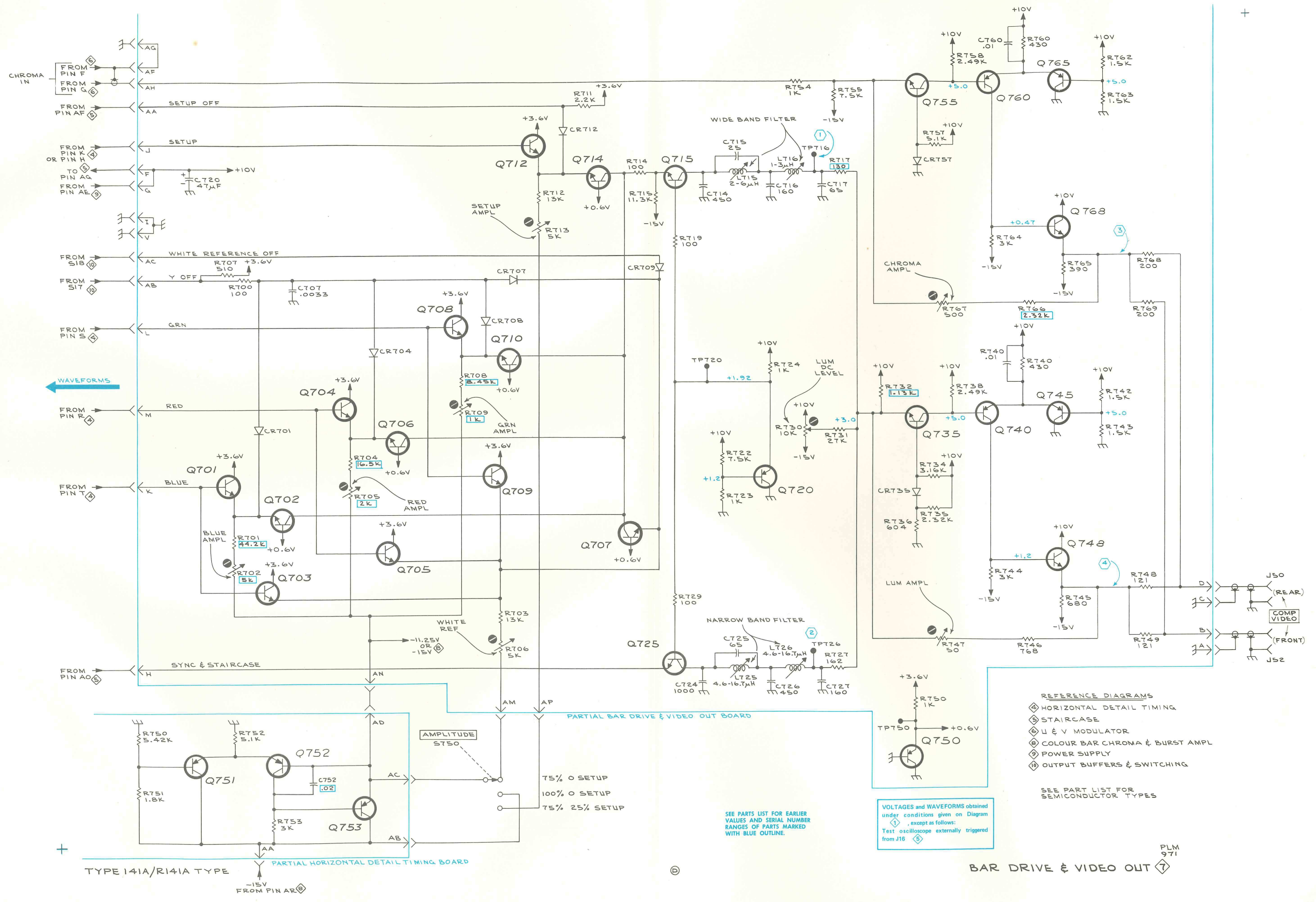

← WAVEFORMS

TYPE 141A/R141A TYPE

PARTIAL BAR DRIVE & VIDEO OUT BOARD

BAR DRIVE & VIDEO OUT

- REFERENCE DIAGRAMS
- ⊠ HORIZONTAL DETAIL TIMING
  - ⊡ STAIRCASE
  - ⊞ U & V MODULATOR
  - ⊞ COLOUR BAR CHROMA & BURST AMPL
  - ⊞ POWER SUPPLY
  - ⊞ OUTPUT BUFFERS & SWITCHING

SEE PART LIST FOR SEMICONDUCTOR TYPES

VOLTAGES and WAVEFORMS obtained under conditions given on Diagram, except as follows:  
 ① Test oscilloscope externally triggered from J16

SEE PART LIST FOR EARLIER VALUES AND SERIAL NUMBER RANGES OF PARTS MARKED WITH BLUE OUTLINE.

PLM 971



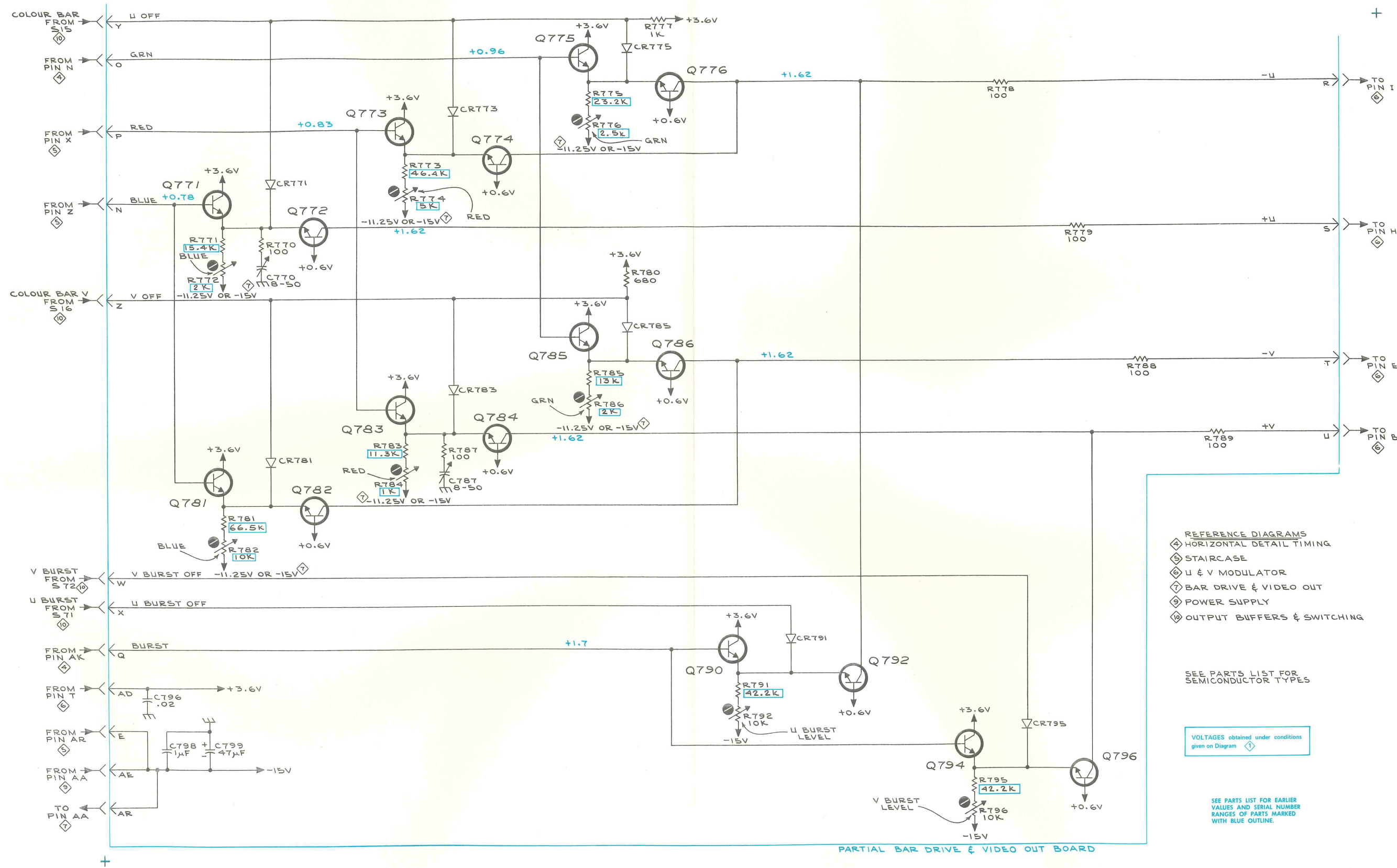

TYPE 141A/R141A

Ⓢ

COLOUR BAR CHROMA & BURST AMPL Ⓢ

PLM  
971

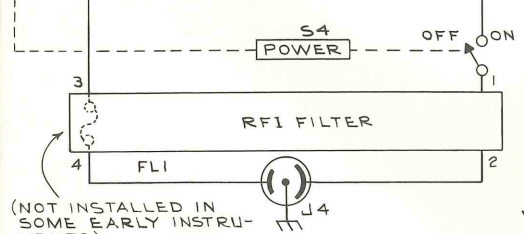
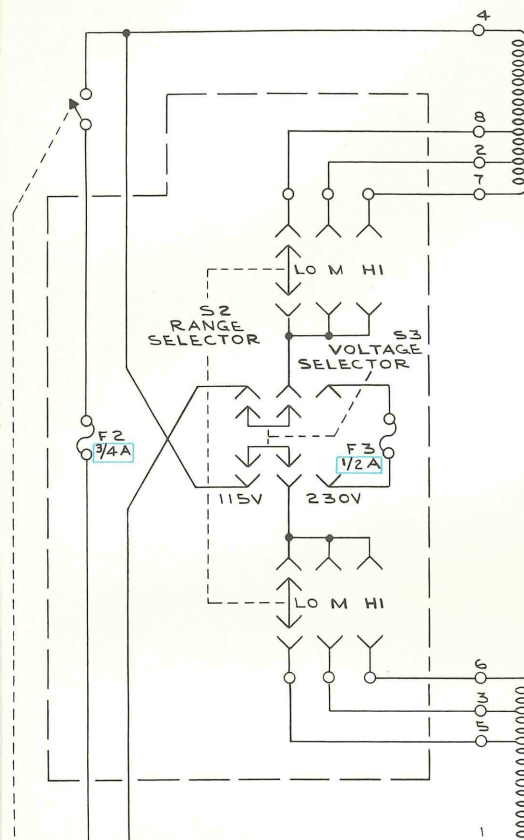
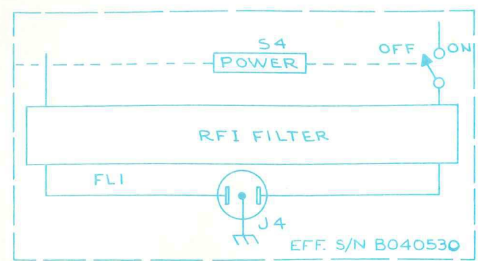

- REFERENCE DIAGRAMS
- ① SUBCARRIER OSCILLATOR & OUTPUT
  - ② VERTICAL
  - ③ HORIZONTAL COLOUR LOCK
  - ④ HORIZONTAL DETAIL TIMING
  - ⑤ U & V MODULATOR
  - ⑥ BAR DRIVE & VIDEO OUT
  - ⑦ COLOUR BAR CHROMA & BURST AMPLIFIER
  - ⑧ OUTPUT AMPS

SEE PARTS LISTS FOR SEMICONDUCTOR TYPES

VOLTAGES obtained under conditions given on Diagram

SEE PARTS LIST FOR EARLIER VALUES AND SERIAL NUMBER RANGES OF PARTS MARKED WITH BLUE OUTLINE.

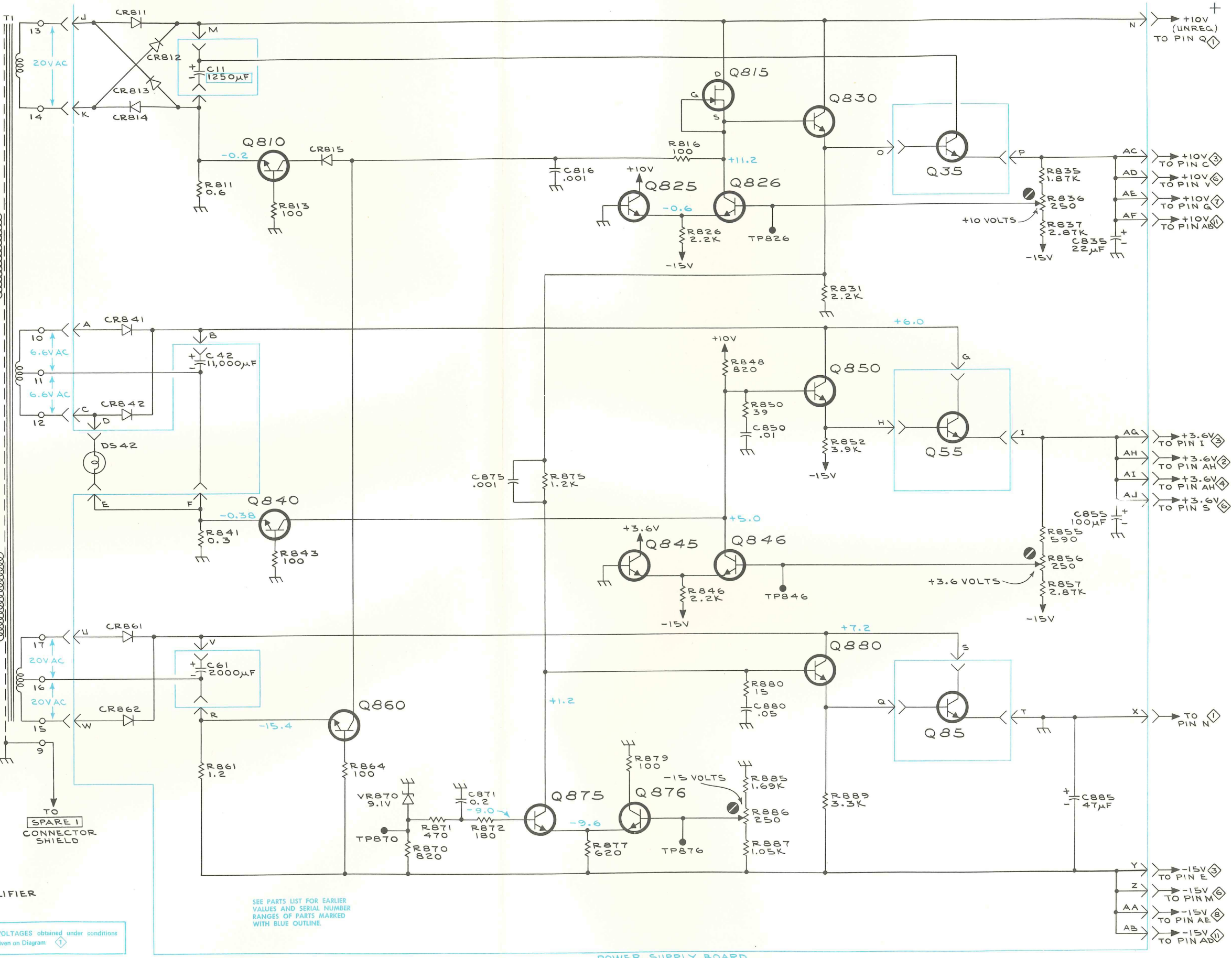

POWER SUPPLY BOARD

PLM 0670



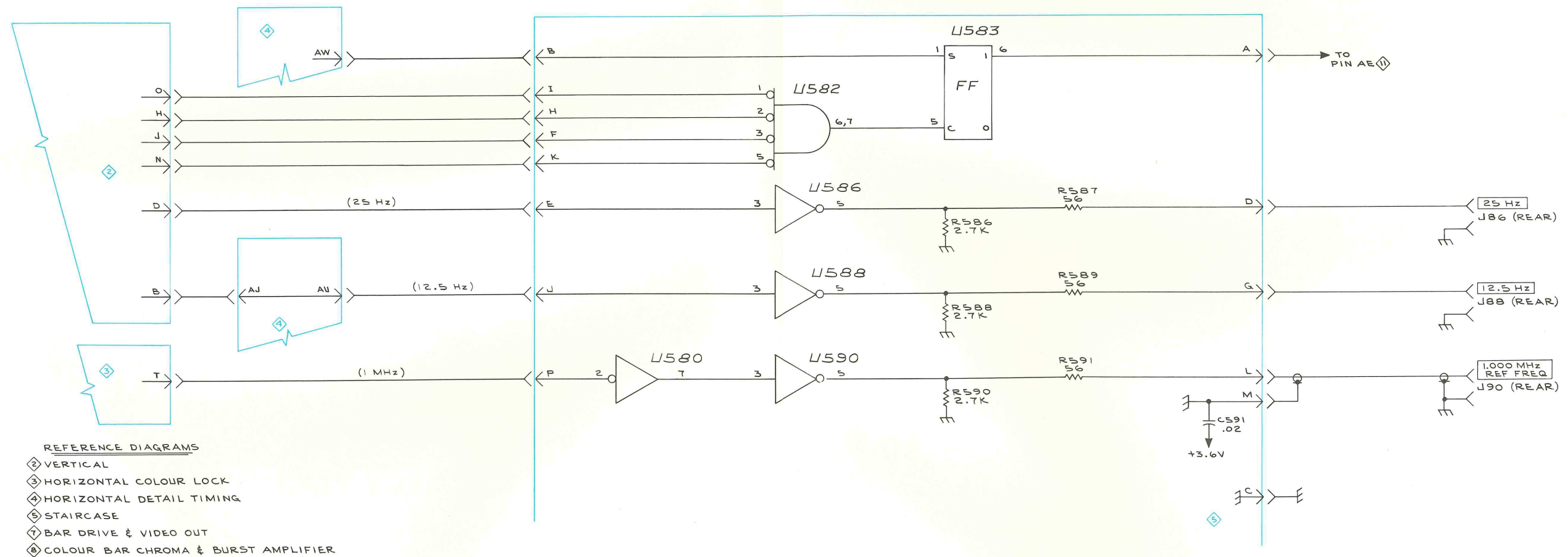
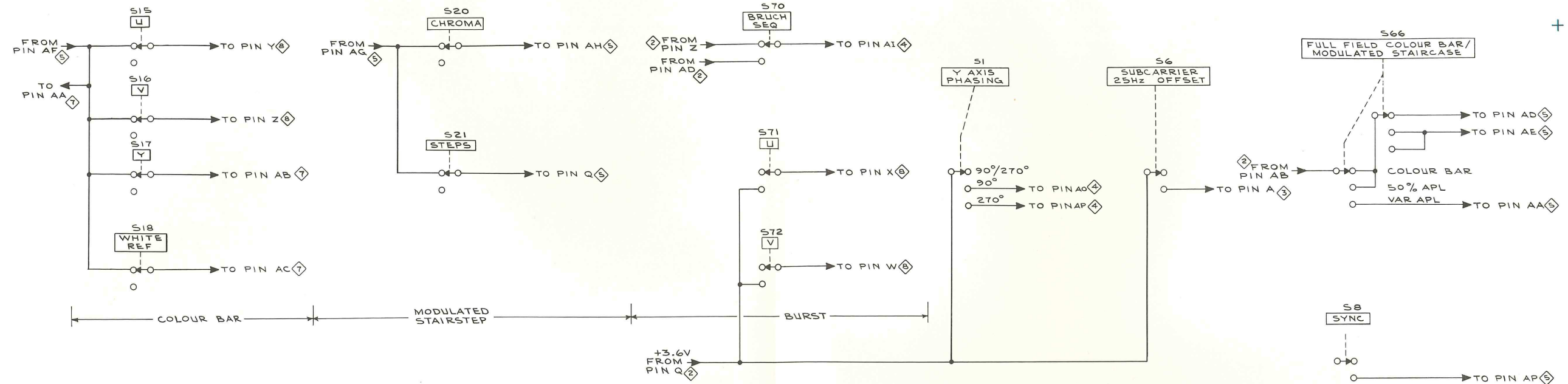

- REFERENCE DIAGRAMS
- ② VERTICAL
  - ③ HORIZONTAL COLOUR LOCK
  - ④ HORIZONTAL DETAIL TIMING
  - ⑤ STAIRCASE
  - ⑦ BAR DRIVE & VIDEO OUT
  - ⑧ COLOUR BAR CHROMA & BURST AMPLIFIER

NOTE:  
1. ALL UNUSED I.C. INPUT PINS ARE GROUNDED

TYPE 141A/R141A

Ⓐ

PLM 669  
BUFFER AMPS & SWITCHING ⑩

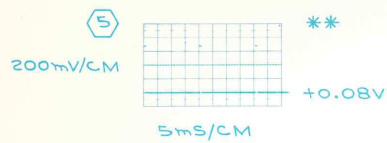
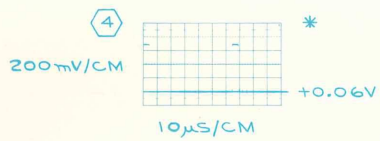
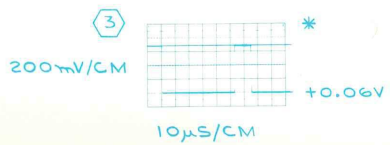
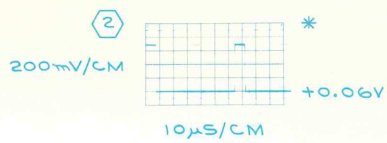
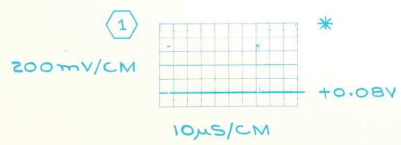

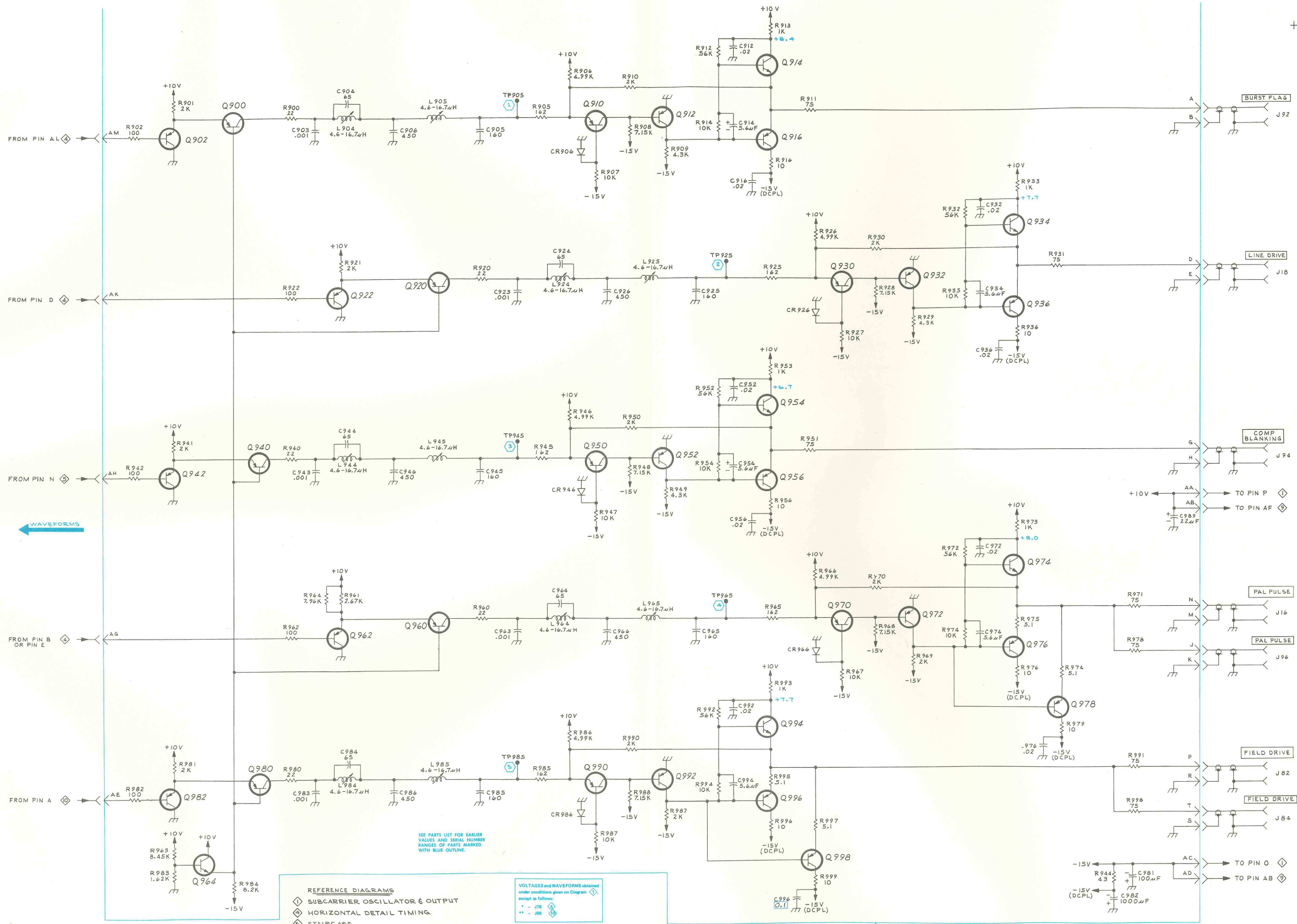

TYPE 141A/R141A

- REFERENCE DIAGRAM
- ① SUBCARRIER OSCILLATOR & OUTPUT
  - ② HORIZONTAL DETAIL TIMING
  - ③ STAIRCASE
  - ④ POWER SUPPLY
  - ⑤ BUFFER AMPS & SWITCHING

VOLTAGES and WAVEFORMS obtained under conditions given on Diagram except as follows:

- - - J78
- - - J88

SEE PARTS LIST FOR SEMICONDUCTOR TYPES

PARTIAL OUTPUT AMPS BOARD

OUTPUT AMPS WLB 971



FIG. 1 FRONT & CHASSIS

+

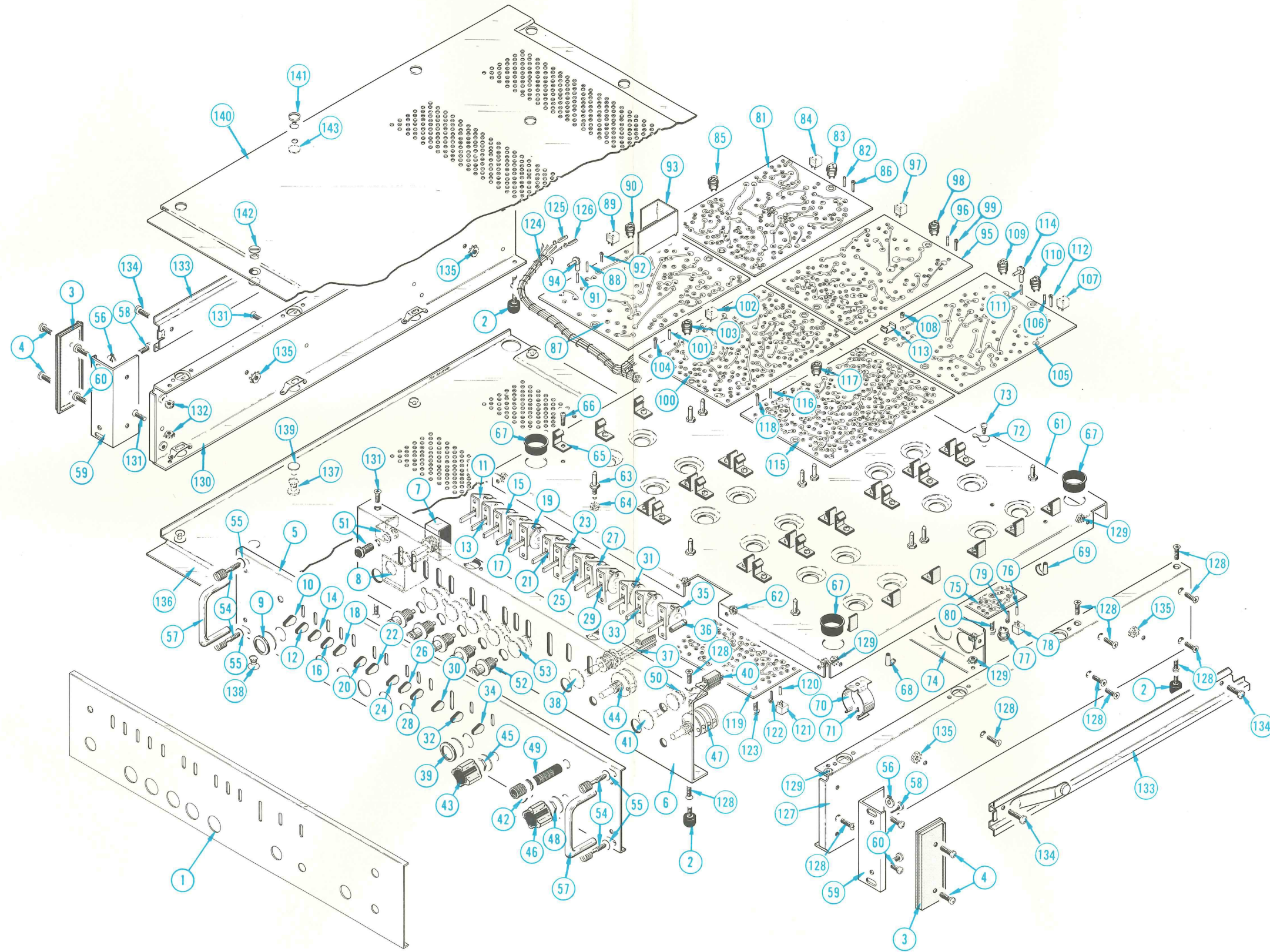

FIG. 1

+A

TYPE 141A/R141A PAL TELEVISION TEST SIGNAL GENERATOR



FIG. 2 REAR

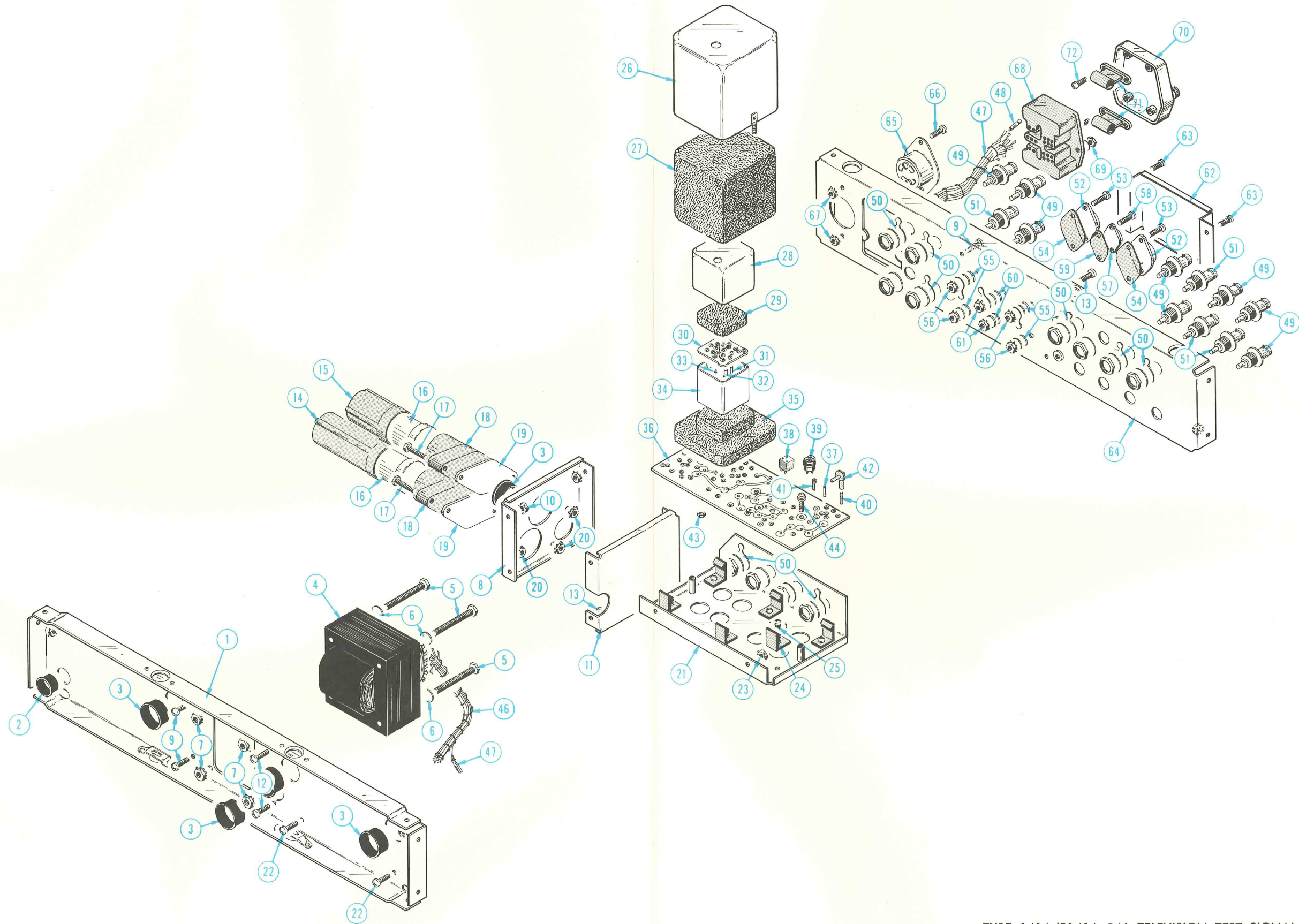

FIG. 2

REPACKAGING

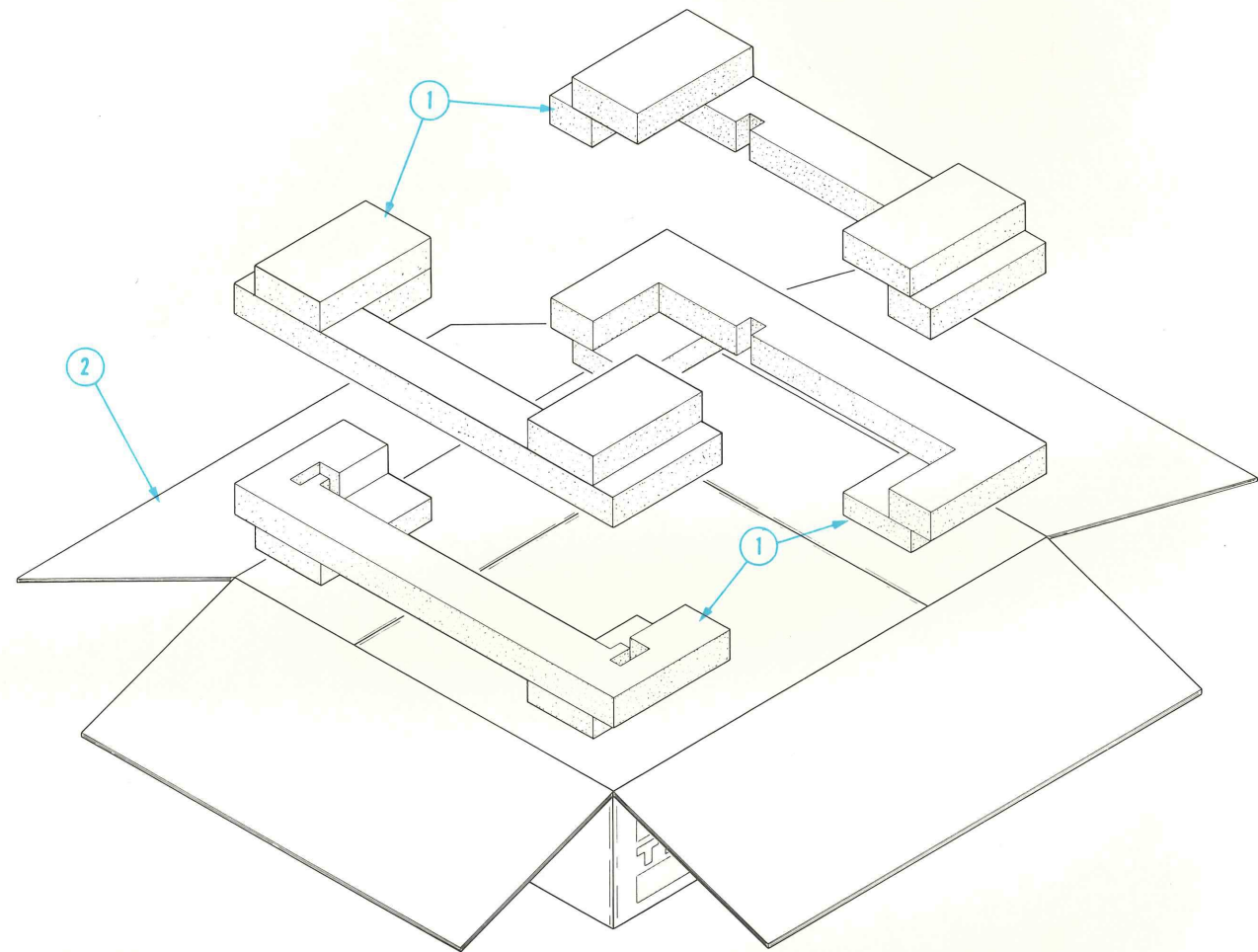

Fig. & Index No.	Tektronix Part No.	Serial/Model No.		Qty	Description				
		Eff	Disc		1	2	3	4	5
3-	065-0163-00			1	CARTON ASSEMBLY				
	-----			-	carton assembly includes:				
-1	004-0291-00			2	FRAME				
-2	004-0807-00			1	CARTON				

®

ACCESSORIES

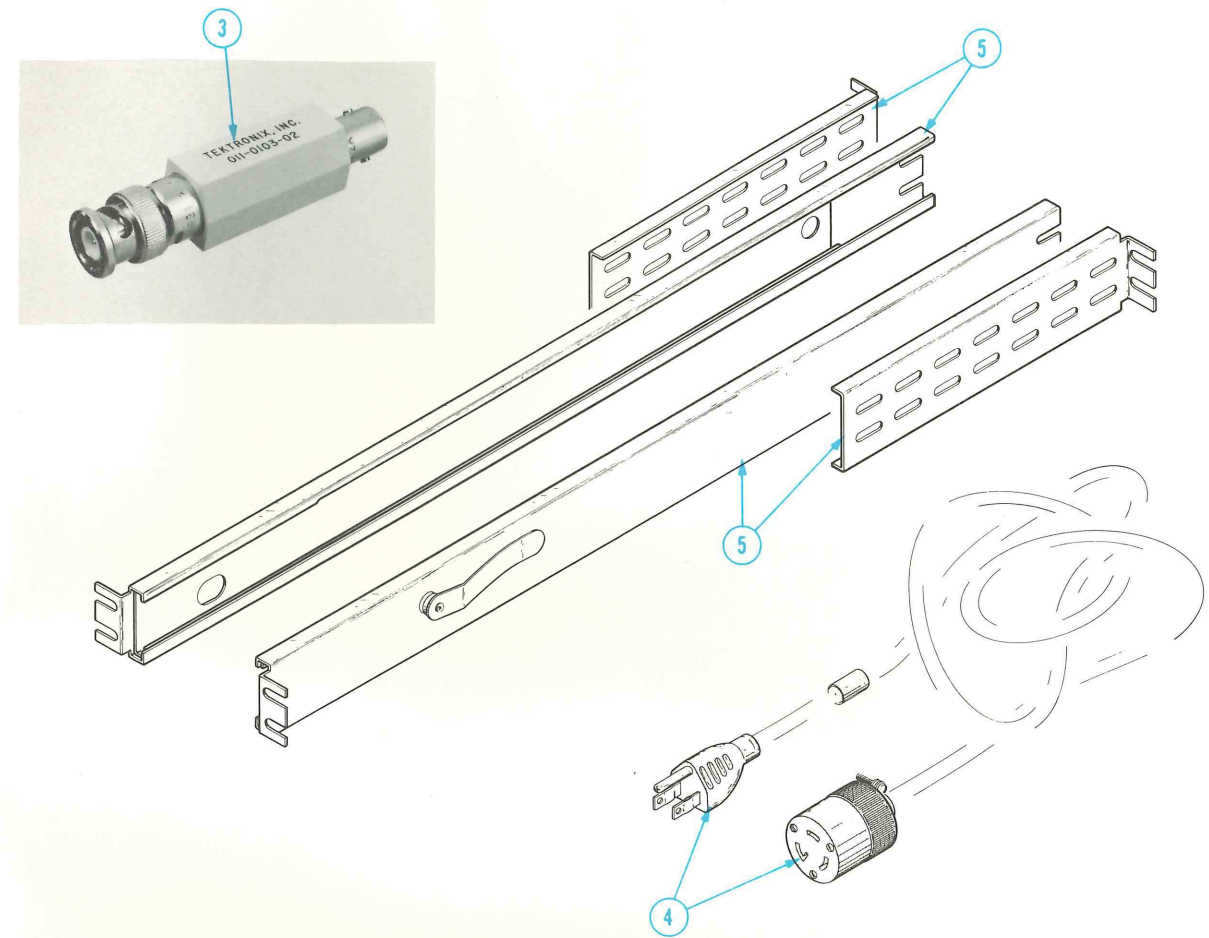
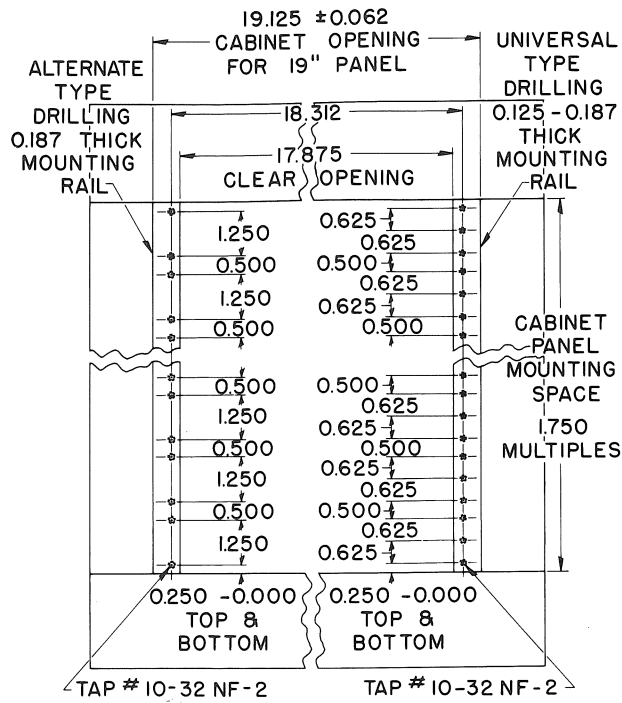

Fig. & Index No.	Tektronix Part No.	Serial/Model No.		Qty	Description				
		Eff	Disc		1	2	3	4	5
3-3	011-0103-02			1	TERMINATION, 75 Ω, BNC				
-4	161-0036-00			1	CORD, power, 3 wire, 7.50 feet long.				
-5	351-0195-00			1	TRACK, slide pair, (rackmount only)				
	070-1008-00			1	MANUAL, instruction (not shown)				

FIG. 3 ACCESSORIES & REPACKAGING



RACK RAIL TYPES



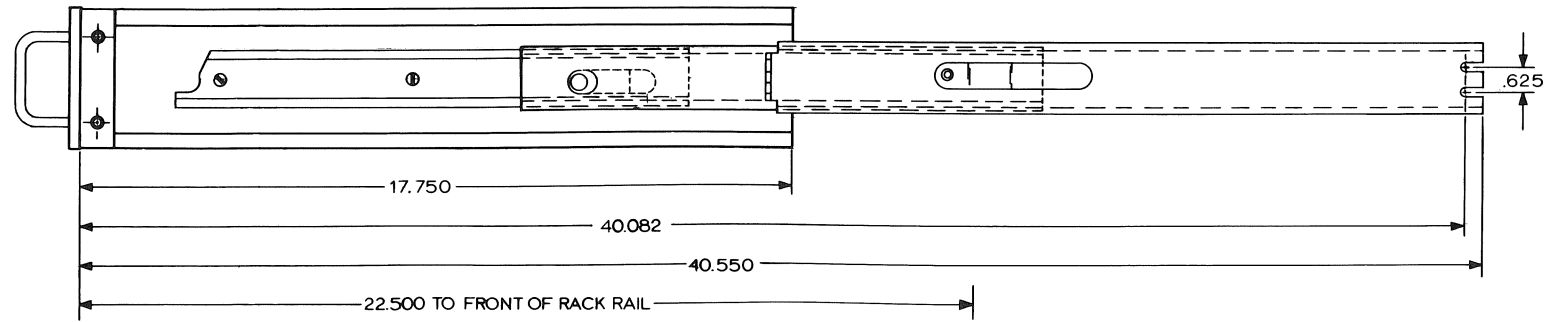
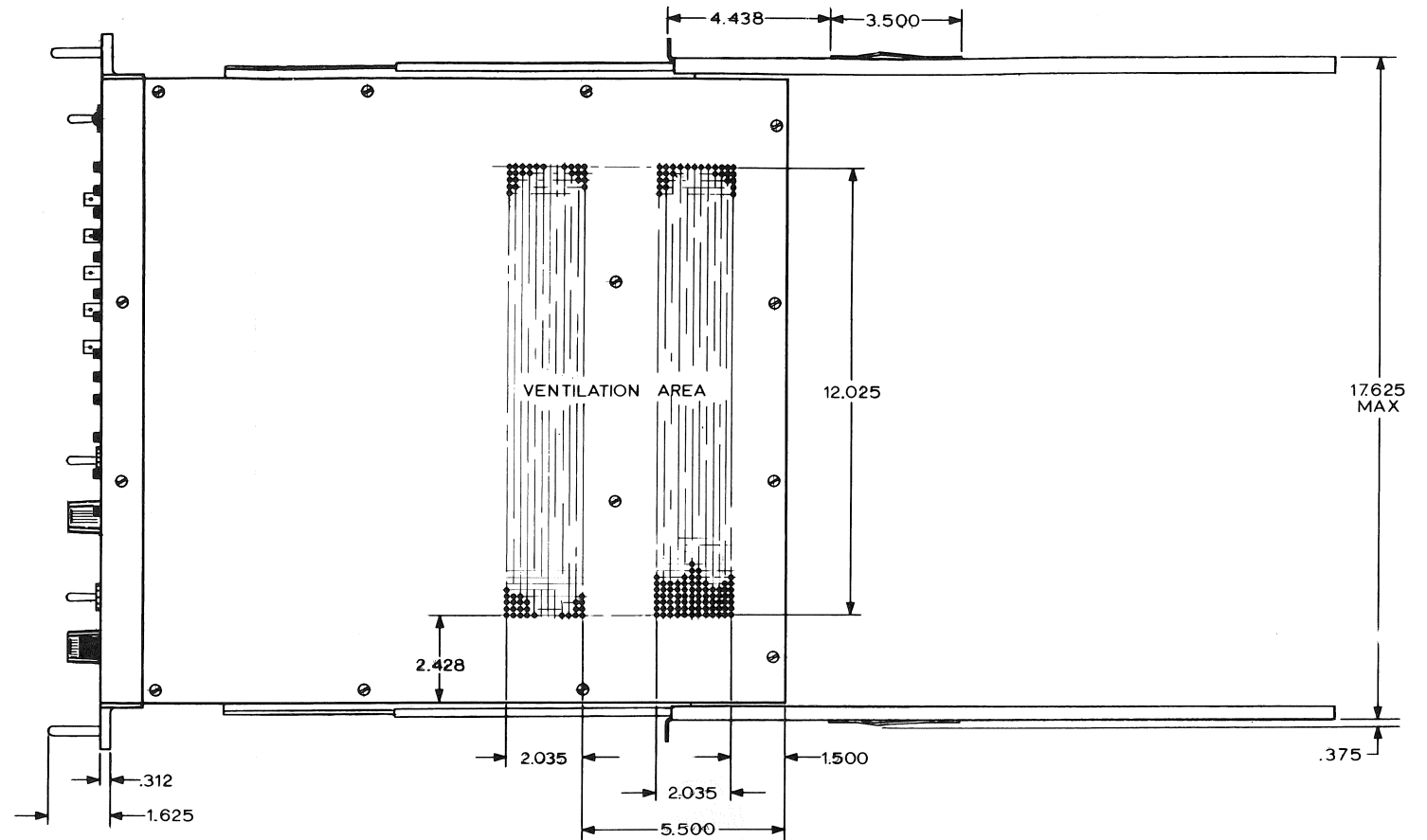
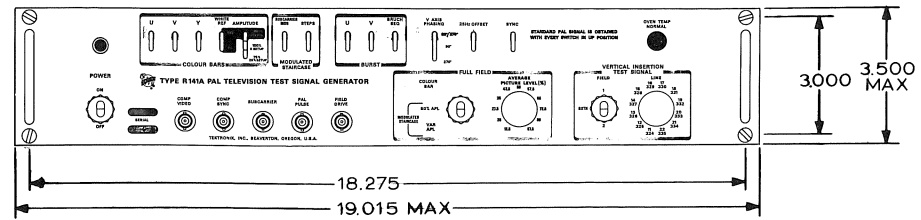
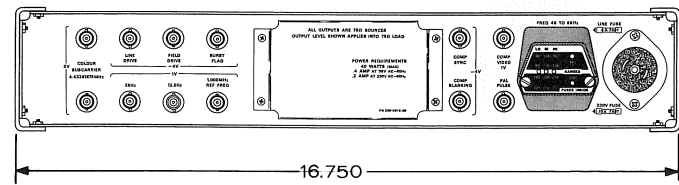

TYPE R 141A

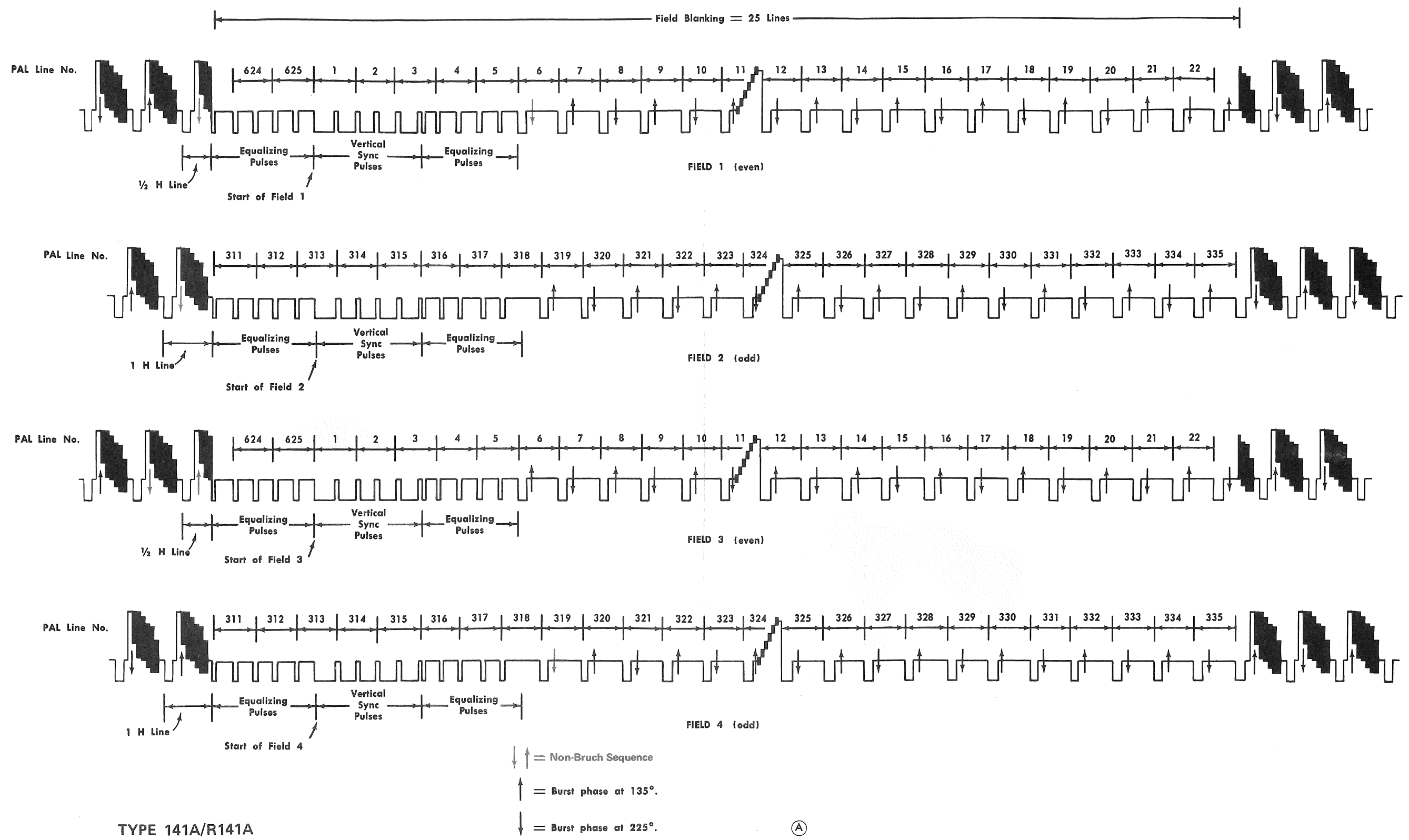

TYPE 141A/R141A

(A)

Time-related waveforms showing relation of input signal to resulting signals at test points and pin connectors. Dashed lines indicate measurement points for signals directly connected to input. Dotted lines represent points which are closely related to actual input signals and may be of opposite polarity from true input signal.

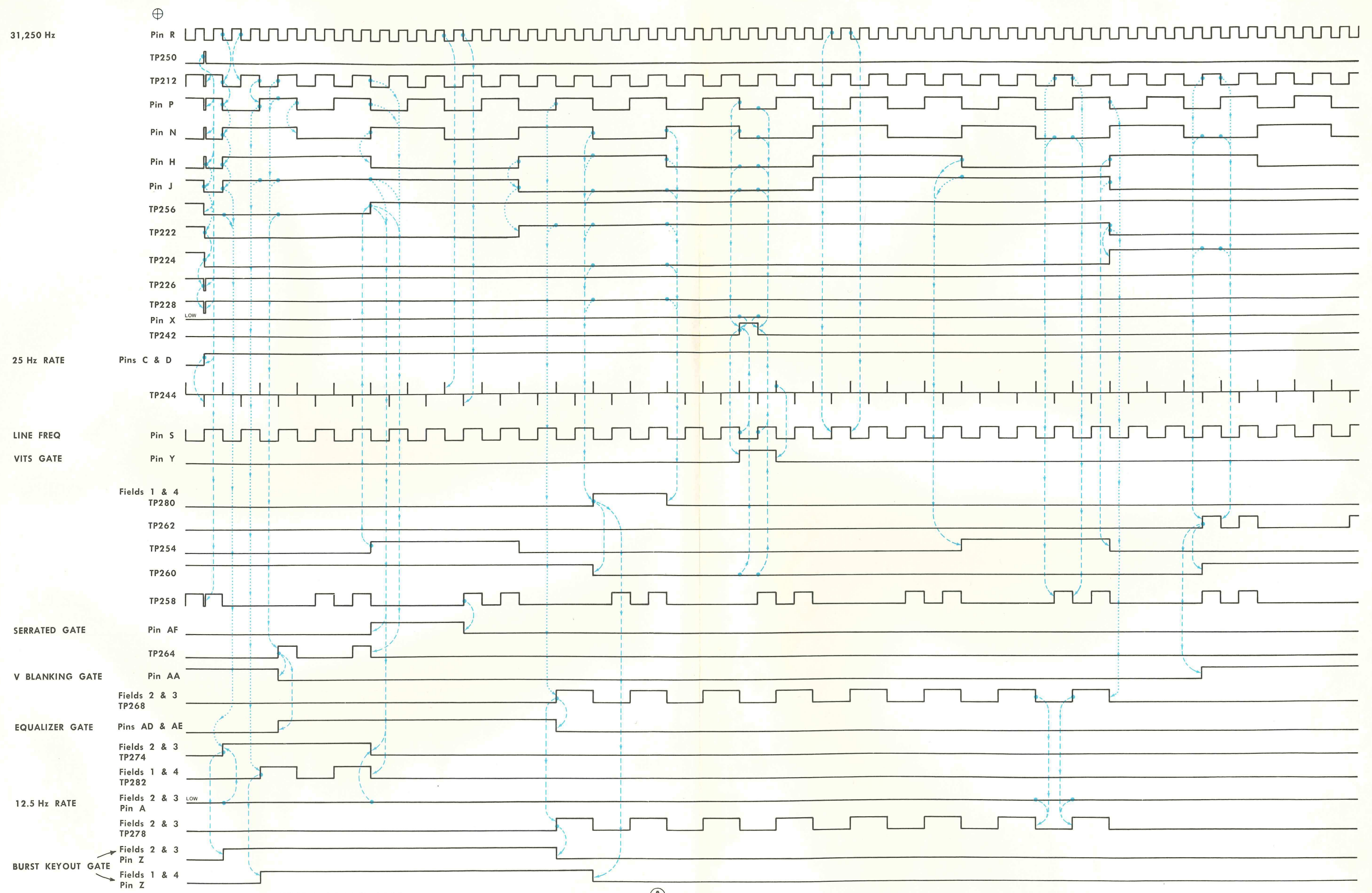

TYPE 141A/R141A

(A)

# SECTION 9

## RACKMOUNTING

### Rackmounting Instructions

#### Mounting Method (Figs. 9-1, 9-2, 9-5 and 9-6)

This instrument will fit most commercial consoles and most 19-inch wide racks whose front and rear rail holes conform to Universal, EIA, RETMA and Western Electric hole spacing.

Fig. 9-1 shows the instrument installed in a cabinet type rack with 1 $\frac{3}{4}$ -inch wide slide-out tracks for a non-tilt installation. The instrument is secured into the rack by means of four captive thumb screws. When the thumb screws on the front panel are loosened, the instrument can be pulled out of the rack like a drawer to its fully extended position (see Fig. 9-2). This position permits many routine maintenance functions to be performed without completely removing the instrument from the rack.

The slide-out tracks easily mount to the cabinet rack front and rear vertical mounting rails if the inside distance between the front and rear rails is within 10 $\frac{1}{2}$  inches to 24 $\frac{1}{2}$  inches. Some means of support (for example, make extensions for the rear mounting brackets) is needed to support the rear ends of the slide-out tracks if the tracks are going to be installed in a cabinet rack whose inside dimension between front and rear rails is not the proper distance (10 $\frac{1}{2}$  inches to 24 $\frac{1}{2}$  inches).

#### Instrument Dimension

The last pullout page in this section shows dimensional drawings exclusive of the power cord and cables.

**Width**—A standard 19-inch rack may be used. The dimension or opening between the front rails must be at least 17 $\frac{5}{8}$  inches (see Fig. 9-2) for a cabinet rack in which the front lip of the stationary section is mounted behind an untapped front rail as shown in the right-hand illustration of Fig. 9-6. This dimension allows room on each side of the instrument for the slide-out tracks to operate so the instrument can move freely in and out of the rack.

**Depth**—For proper circulation of cooling air, allow at least 2 inches clearance behind the rear of the instrument and any enclosure on the rack (see dimensional drawing). If it is sometimes necessary or desirable to operate the Type R141A in the fully extended position, use cables that are long enough to reach from the instrument to the location where the signal(s) need to be applied.

### Rackmounting in a Cabinet Rack

**General Information**—The slide-out tracks for the instrument consist of two assemblies, one for the left side of the instrument and one for the right side. Each assembly consists of three sections as illustrated in Fig. 9-3. The stationary section attaches to the front and rear rails of the rack with inside dimensions as indicated in Fig. 9-2; the chassis section attaches to the instrument and is installed at the factory; the intermediate section fits between the other two sections to allow the instrument to be fully extended out of the rack.

The small hardware components included with the slide-out track assemblies are shown in Fig. 9-4. The hardware shown in Fig. 9-4 is used to mount the slide-out tracks to the rack rails having this compatibility.

(a) Front and rear rail holes must be large enough to allow inserting a 10-32 screw through the rail mounting holes (see Fig. 9-6).

(b) Front rail holes may have already been countersunk prior to this installation.

Because of the compatibility given in (b), there will be some screws left over.

The stationary and intermediate sections for both sides of the rack are shipped as a matched set and should not be separated. The matched sets for both sides including hardware are marked 351-0195-00 on the package. To identify the assemblies, note that the automatic latch and intermediate section stop are located near the top of the matched sets when they are properly mated to the chassis sections as shown in Fig. 9-3.

**Mounting Procedure**—Use the following procedure to mount both sets. See Figs. 9-5 and 9-6 for installation details.

1. To mount the instrument directly above or below another instrument in the cabinet rack, select the appropriate holes in the front rack rails for the stationary sections using Fig. 9-5 as a guide.

2. Mount the stationary slide-out track sections to the front rack rails using either of these methods:

(a) If the front rails are **not** countersunk, use the pan head screws and bar nuts to mount the stationary sections similar to the right-hand illustration shown in Fig. 9-6.

(b) If the front rails **are** countersunk, use the flat head screws and bar nuts to mount the stationary sections as shown in Fig. 9-6 right-hand illustration.

3. Mount the stationary slide-out track sections to the non-tapped rear rails using this method:

Mount the left stationary section with hardware provided as shown in the left-hand or center illustration in Fig. 9-6. Note that the rear mounting bracket can be installed either way so the slide-out tracks will fit a deep or shallow cabinet rack. Use Fig. 9-6 as a guide for mounting the right stationary section. Make sure the stationary sections are horizontally aligned so they are level and parallel with each other.

### Adjustments

To adjust the slide-out tracks for smooth operation, proceed as follows:

1. Insert the instrument into the rack as described and as shown in steps 1 through 4 of Fig. 9-7 installation procedure.

2. Adjust the slide-out tracks for proper spacing as shown in Fig. 9-8.

### Maintenance

The slide-out tracks require no lubrication. The special dark gray finish on the sliding parts is a permanent lubrication.



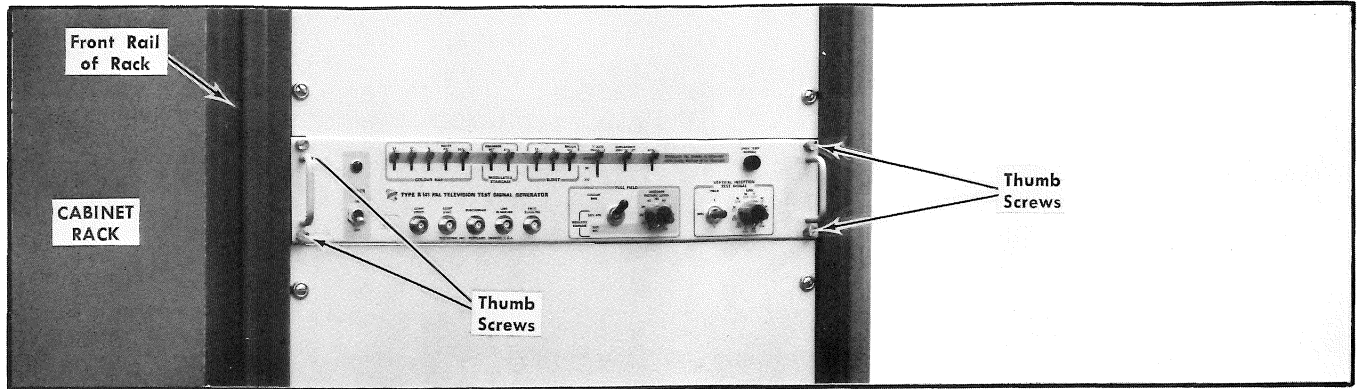

Fig. 9-1. The Type R141A installed in a cabinet type rack.

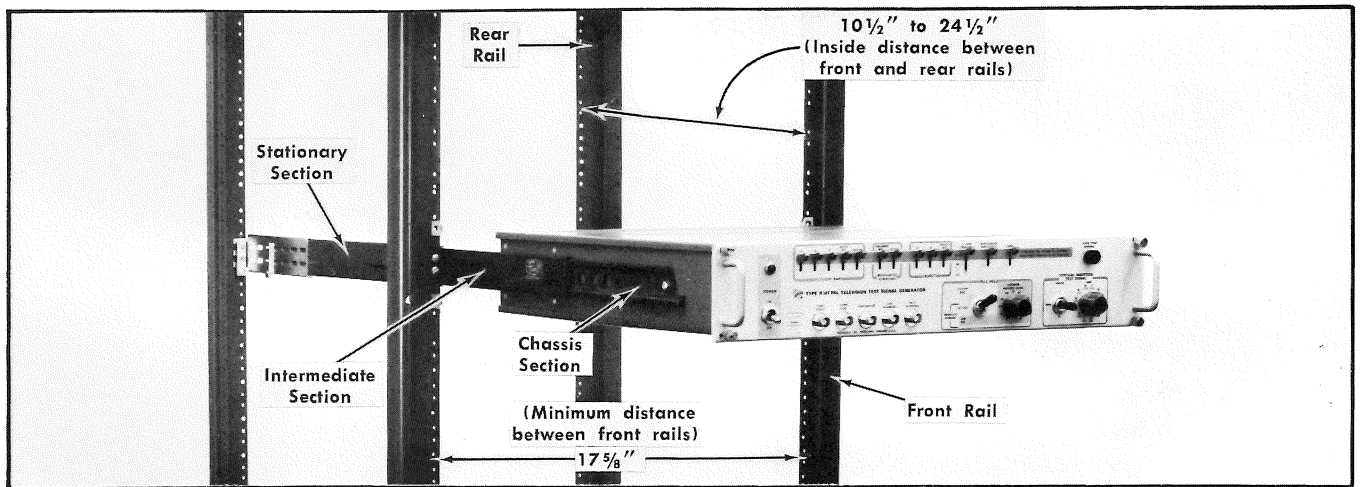

Fig. 9-2. The Type R141A shown in the fully extended position. The cabinet rack sides have been removed from the rack to show mounting details.

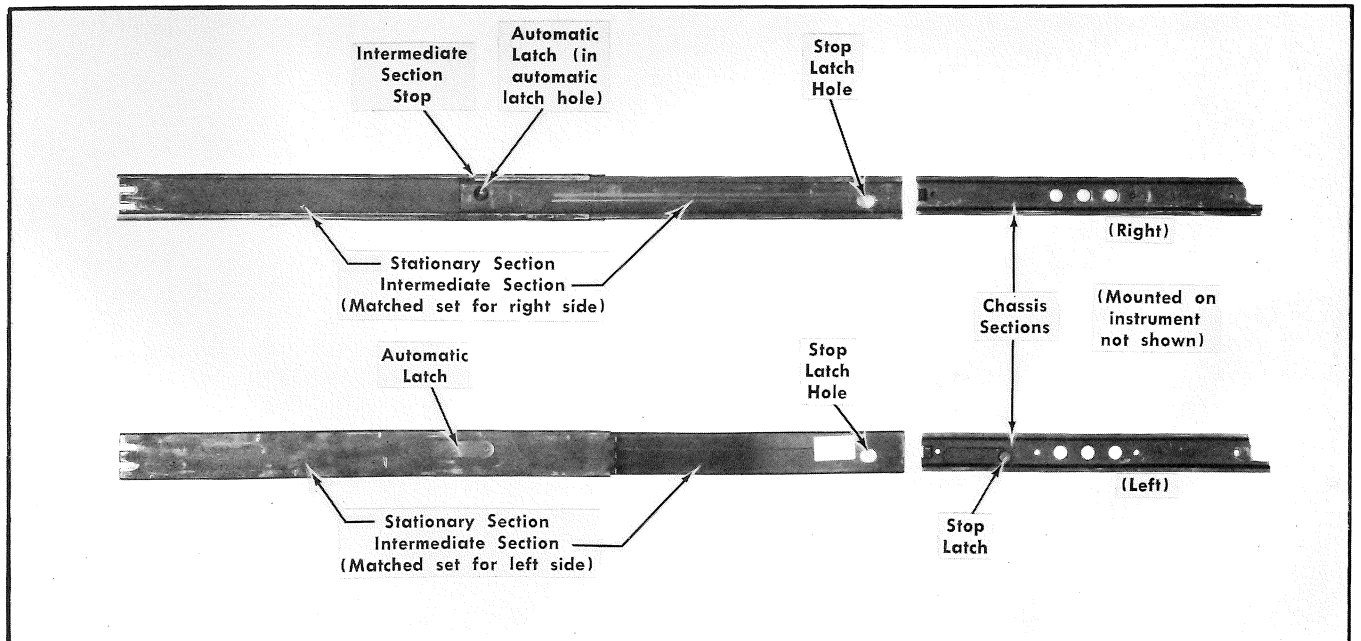

Fig. 9-3. Illustration showing the 1 3/4-inch wide slide-out track assemblies.



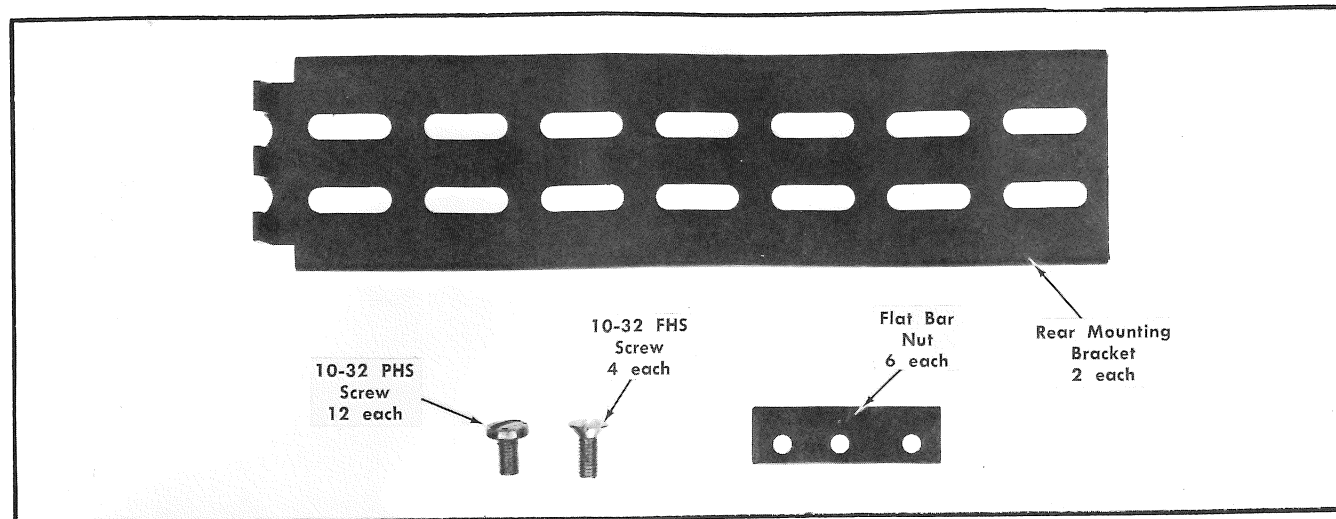

Fig. 9-4. Small hardware components for mounting the stationary sections to the rack rails.

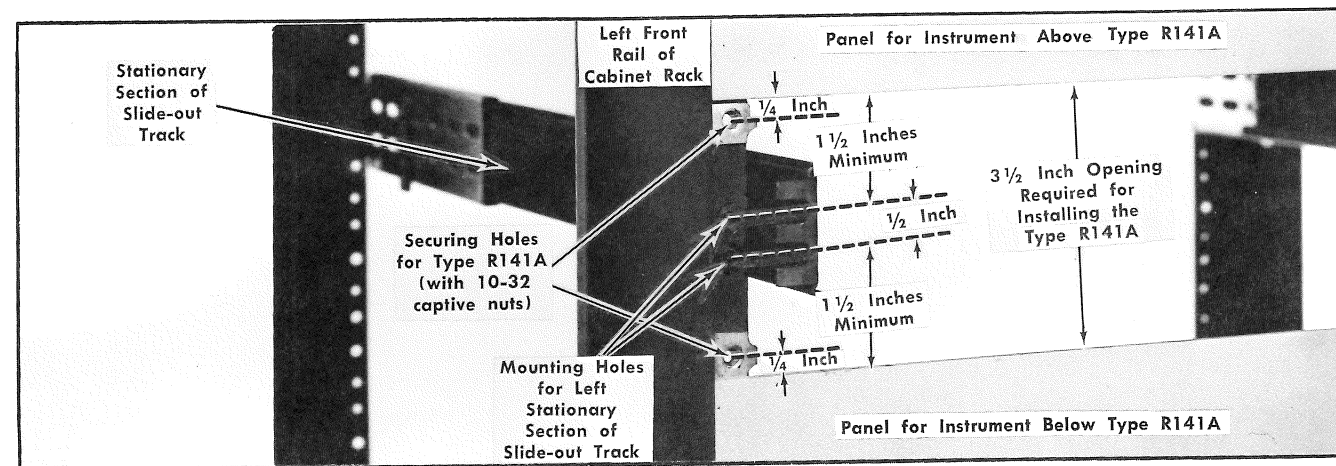

Fig. 9-5. Vertical mounting position of the left stationary section and location of the securing holes. These same dimensions apply to the right front rail.

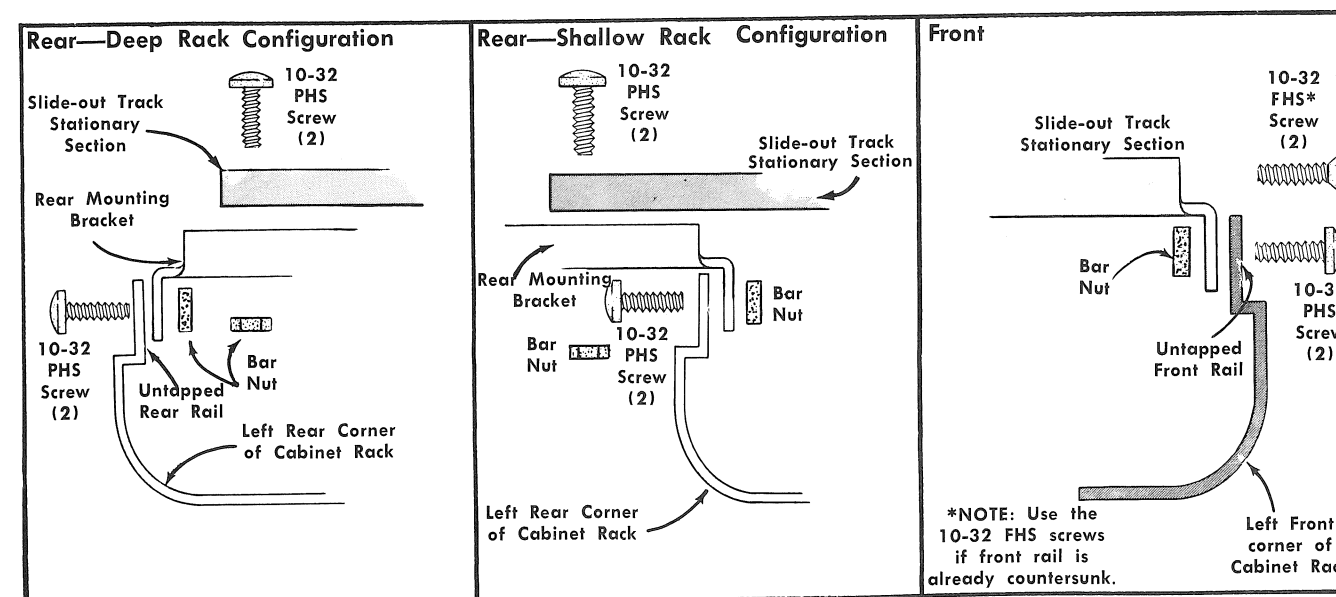

Fig. 9-6. Top view of cabinet rack showing mounting position of the left stationary section to the rails of the rack. Since the rails are not tapped, bar nuts are used to mount the stationary section to the rack rails.

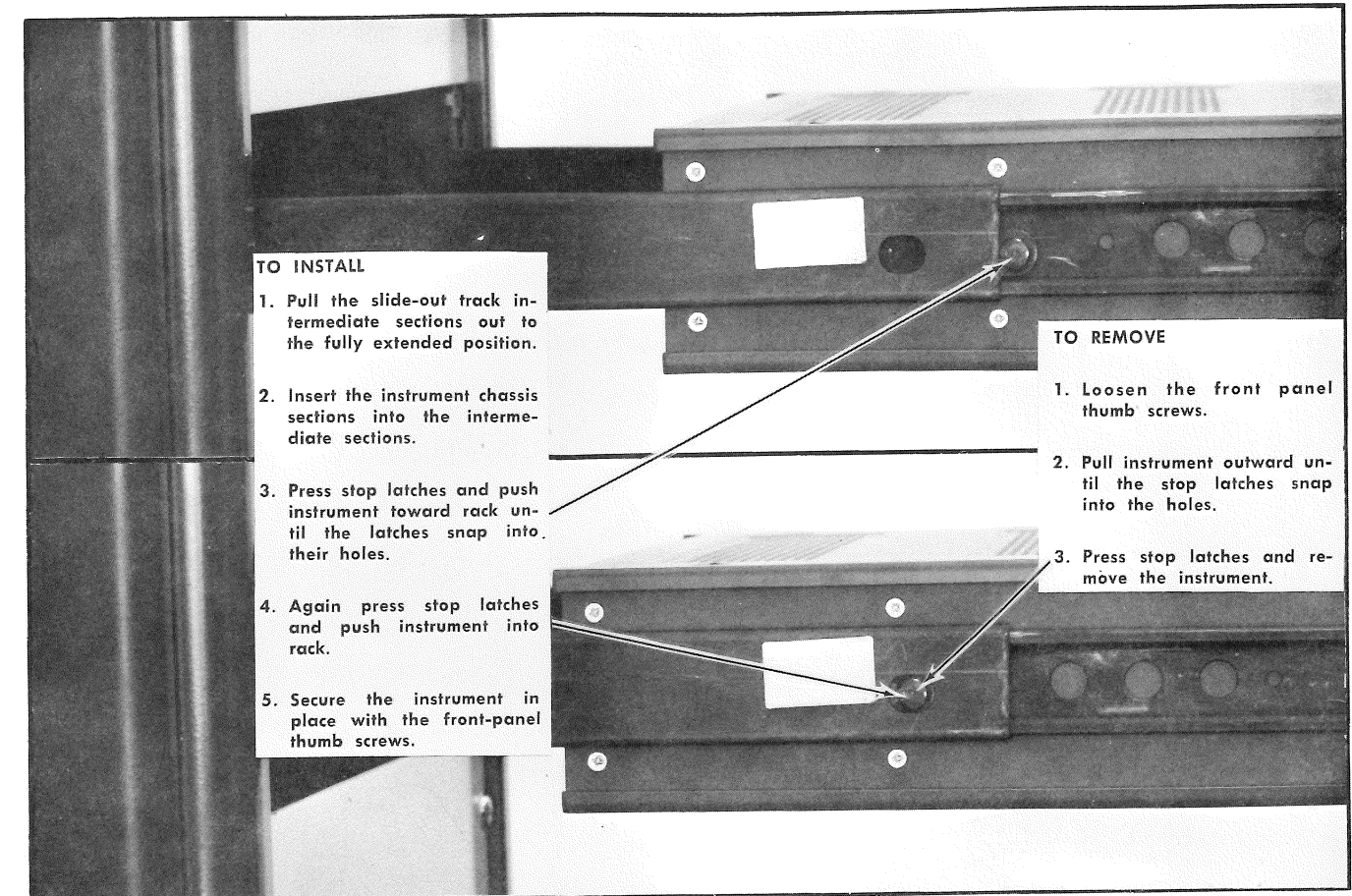

Fig. 9-7. Installing and removing the instrument.

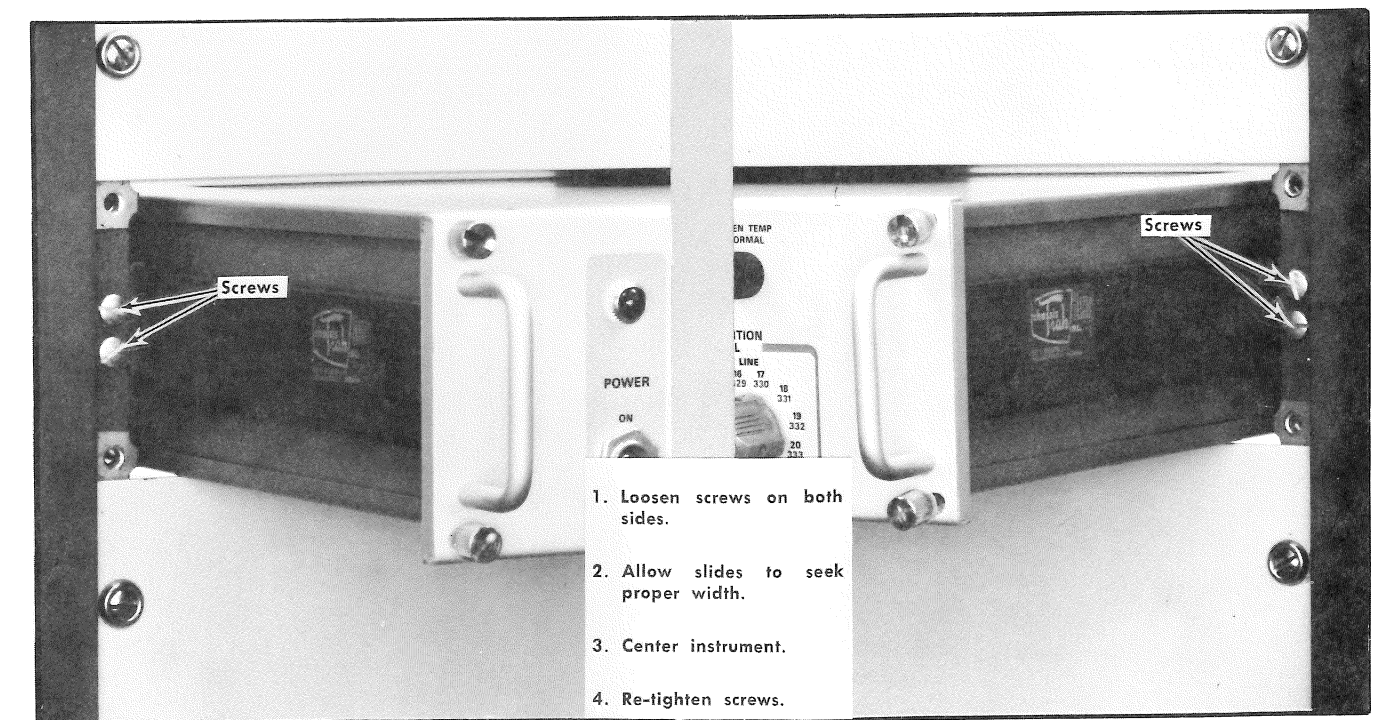

Fig. 9-8. Adjusting the slide-out tracks for smooth sliding action.

## **MANUAL CHANGE INFORMATION**

At Tektronix, we continually strive to keep up with latest electronic developments by adding circuit and component improvements to our instruments as soon as they are developed and tested.

Sometimes, due to printing and shipping requirements, we can't get these changes immediately into printed manuals. Hence, your manual may contain new change information on following pages.

A single change may affect several sections. Since the change information sheets are carried in the manual until all changes are permanently entered, some duplication may occur. If no such change pages appear following this page, your manual is correct as printed.

## **SERVICE NOTE**

Because of the universal parts procurement problem, some electrical parts in your instrument may be different from those described in the Replaceable Electrical Parts List. The parts used will in no way alter or compromise the performance or reliability of this instrument. They are installed when necessary to ensure prompt delivery to the customer. Order replacement parts from the Replaceable Electrical Parts List.

# CALIBRATION TEST EQUIPMENT REPLACEMENT

## Calibration Test Equipment Chart

This chart compares TM 500 product performance to that of older Tektronix equipment. Only those characteristics where significant specification differences occur, are listed. In some cases the new instrument may not be a total functional replacement. Additional support instrumentation may be needed or a change in calibration procedure may be necessary.

### Comparison of Main Characteristics

DM 501 replaces 7D13		
PG 501 replaces 107	PG 501 - Risetime less than 3.5 ns into 50 $\Omega$ .	107 - Risetime less than 3.0 ns into 50 $\Omega$ .
108	PG 501 - 5 V output pulse; 3.5 ns Risetime.	108 - 10 V output pulse; 1 ns Risetime.
111	PG 501 - Risetime less than 3.5 ns; 8 ns Pretrigger pulse delay.	111 - Risetime 0.5 ns; 30 to 250 ns Pretrigger Pulse delay.
114	PG 501 - $\pm 5$ V output.	114 - $\pm 10$ V output. Short proof output.
115	PG 501 - Does not have Paired, Burst, Gated, or Delayed pulse mode; $\pm 5$ V dc Offset. Has $\pm 5$ V output.	115 - Paired, Burst, Gated, and Delayed pulse mode; $\pm 10$ V output. Short-proof output.
PG 502 replaces 107	PG 502 - 5 V output	108 - 10 V output.
108	PG 502 - Risetime less than 1 ns; 10 ns Pretrigger pulse delay.	111 - Risetime 0.5 ns; 30 to 250 ns Pretrigger pulse delay.
111	PG 502 - $\pm 5$ V output	114 - $\pm 10$ V output. Short proof output.
114	PG 502 - Does not have Paired, Burst, Gated, Delayed & Undelayed pulse mode; Has $\pm 5$ V output.	115 - Paired, Burst, Gated, Delayed & Undelayed pulse mode; $\pm 10$ V output. Short-proof output.
115	PG 502 - Does not have Paired or Delayed pulse. Has $\pm 5$ V output.	2101 - Paired and Delayed pulse; 10 V output.
2101		
PG 506 replaces 106	PG 506 - Positive-going trigger output signal at least 1 V; High Amplitude output, 60 V.	106 - Positive and Negative-going trigger output signal, 50 ns and 1 V; High Amplitude output, 100 V.
067-0502-01	PG 506 - Does not have chopped feature.	0502-01 - Comparator output can be alternately chopped to a reference voltage.
SG 503 replaces 190, 190A, 190B	SG 503 - Amplitude range 5 mV to 5.5 V p-p.	190B - Amplitude range 40 mV to 10 V p-p.
191	SG 503 - Frequency range 250 kHz to 250 MHz.	191 - Frequency range 350 kHz to 100 MHz.
067-0532-01	SG 503 - Frequency range 250 kHz to 250 MHz.	0532-01 - Frequency range 65 MHz to 500 MHz.
TG 501 replaces 180, 180A	TG 501 - Marker outputs, 5 sec to 1 ns. Sinewave available at 5, 2, and 1 ns. Trigger output - slaved to marker output from 5 sec through 100 ns. One time-mark can be generated at a time.	180A - Marker outputs, 5 sec to 1 $\mu$ s. Sinewave available at 20, 10, and 2 ns. Trigger pulses 1, 10, 100 Hz; 1, 10, and 100 kHz. Multiple time-marks can be generated simultaneously.
181	TG 501 - Marker outputs, 5 sec to 1 ns. Sinewave available at 5, 2, and 1 ns.	181 - Marker outputs, 1, 10, 100, 1000, and 10,000 $\mu$ s, plus 10 ns sinewave.
184	TG 501 - Marker outputs, 5 sec to 1 ns. Sinewave available at 5, 2, and 1 ns. Trigger output - slaved to marker output from 5 sec through 100 ns. One time-mark can be generated at a time.	184 - Marker outputs, 5 sec to 2 ns. Sinewave available at 50, 20, 10, 5, and 2 ns. Separate trigger pulses of 1 and .1 sec; 10, 1, and .1 ms; 10 and 1 $\mu$ s. Marker amplifier provides positive or negative time marks of 25 V min. Marker intervals of 1 and .1 sec; 10, 1, and .1 ms; 10 and 1 $\mu$ s.
2901	TG 501 - Marker outputs, 5 sec to 1 ns. Sinewave available at 5, 2, and 1 ns. Trigger output - slaved to marker output from 5 sec through 100 ns. One time-mark can be generated at a time.	2901 - Marker outputs, 5 sec to 0.1 $\mu$ s. Sinewave available to 50, 10, and 5 ns. Separate trigger pulses, from 5 sec to 0.1 $\mu$ s. Multiple time-marks can be generated simultaneously.

**NOTE: All TM 500 generator outputs are short-proof. All TM 500 plug-in instruments require TM 500-Series Power Module.**



**TEKTRONIX®**

committed to  
technical excellence

# MANUAL CHANGE INFORMATION

PRODUCT 141A/R141A

CHANGE REFERENCE M24,328

EFF SN B141380-up

DATE 3-31-76

CHANGE:

DESCRIPTION

070-1008-00

ELECTRICAL PARTS LIST AND SCHEMATIC CHANGE

CHANGE TO:

Y392      158-0079-00      1 MHz  $\pm$  0.001% Crystal

Y392 is located on the HORIZONTAL COLOUR LOCK circuit board 670-0296-00

and is shown on diagram 3.

