

INSTRUCTION MANUAL
FOR
REGULATED POWER SUPPLIES

MODEL
LPT-7202-FM

This manual provides instructions intended for the operation of Lambda power supplies, and is not to be reproduced without the written consent of Lambda Electronics. All information contained herein applies to model LPT-7202-FM.

LAMBDA ELECTRONICS

MAIN PLANT TELEPHONE: 516 MYrtle 4-4200

MELVILLE, L.I., N.Y.

IM — LPT

TABLE OF CONTENTS

Section	Page
SPECIFICATIONS AND FEATURES	1
THEORY OF OPERATION	4
OPERATING INSTRUCTIONS	5
Controls, Instruments, and Fuses	5
Ground Connections	5
Basic Modes of Operation	5
Supply — Load Connections	6
Detailed Operating Procedures	7
Operation After Protective Device Shutdown	12
MAINTENANCE	13
General	13
Trouble Analysis	13
Checking Transistors and Capacitors	13
Printed Circuit Board Maintenance Techniques	13
Trouble Chart	14
Adjustment of Voltage Calibration Control R108	15
Adjustment of Voltage Calibration Control R108, R208, R308	16
Adjustment of Current Calibration Control R102, R202, R302	16
SERVICE	17
PARTS ORDERING	17

SPECIFICATIONS AND FEATURES

DC OUTPUT — Voltage regulated for line and load. See table I for voltage and current ratings.

**TABLE I
VOLTAGE AND CURRENT RANGES**

VOLTAGE RANGE (VOLTS)	MAXIMUM CURRENT (AMPS) AT AMBIENT TEMPERATURE			
	30°C	40°C	50°C	60°C
0-7 (Unit A)	5.0	4.5	4.0	3.5
0-20 (Unit B)	1.5	1.35	1.20	1.0
0-20 (Unit C)	1.5	1.35	1.20	1.0

Current range must be chosen to suit the appropriate maximum ambient temperature. Current ratings apply for entire voltage range.

REGULATED VOLTAGE OUTPUT

Regulation (line)	0.01 per cent plus 1.0 millivolt for input variations from 105-132 or 132-105 volts AC.
Regulation (load)	0.01 percent plus 1.0 millivolt for load variations from no load to full load or full load to no load.
Remote Programming	
External Resistor	Nominal 200 ohms/volt output.
Programming Voltage	One-to-one voltage change.
Ripple and Noise	500 microvolts rms; 1.5 millivolts peak-to-peak with either positive or negative terminal grounded.
Temperature Coefficient	Output change in voltage less than (0.015% + 0.3 mv)/°C

DC OUTPUT — Current regulated for line and load; automatic crossover with voltage limit.

- Multi-Current Ranges Current range must be chosen to suit the appropriate maximum ambient temperature. Current ratings apply for entire voltage range. For maximum current range, see Table I. Minimum current rating: 45 ma or 1% of max. current rating whichever is greater.
- Voltage Range For voltage range see Table I: voltage ratings apply for entire current range.

REGULATED CURRENT OUTPUT: AUTOMATIC CROSSOVER

- Regulation (line) Less than 0.2% or 5 milliamperes, whichever is greater, variations from 105-132 or 132-105 volts AC.
- Regulation (load) Less than 0.2% or 5 milliamperes for load voltage changes from 0 to max. or max. to 0 volts DC.

AC INPUT — 105-132 volts AC at 47-440 Hz. Input power*: 235 Watts. For 47-53 Hz operation, derate current 10% for each ambient temperature given in table I. For 63-440 Hz operation, consult factory.

*With output loaded to full 30°C rating and input voltage 132 volts AC, 60 Hz.

OVERLOAD PROTECTION

- Thermal Thermostat, resets automatically when over-temperature condition is eliminated.
- Electrical
 - External Adjustable, automatic, electronic current-limiting circuit, settable to 105 percent of rated current, limits output current to preset limit for protection of load and power supply when external overloads and direct shorts occur.
 - Internal "SLO-BLO", 5 A fuse F1 protects the AC input circuit. Overload of the supply does not cause fuse failure.

Fuse F2 provides protection against internal circuit failure in conjunction with overvoltage protector option (Unit A only).

INPUT AND OUTPUT CONNECTIONS — Heavy duty terminal blocks on rear of chassis with 5-foot, 3 wire detachable line cord; five-way binding posts provide for additional positive (+), ground, and negative (-) DC output connection on front panel.

OVERSHOOT — No overshoot of output voltage under conditions of power turn-on, power turn-off or power failure.

OPERATING AMBIENT TEMPERATURE RANGE AND DUTY CYCLE — Continuous duty from 0°C to 60°C ambient with corresponding load current ratings for all modes of operation.

STORAGE TEMPERATURE — -55°C to + 85°C
(non-operating)

METERS — Voltmeters and ammeters.

CONTROLS

DC Output Controls Coarse and fine voltage controls and coarse current control permit adjustment of DC output; located on front panel.

Binding Posts (+) (-) (GND) Five-way binding posts.

Remote Sensing Provision is made for remote sensing to eliminate effect of power output lead resistance on DC regulation.

Power Panel mounted switch and indicator light.

PHYSICAL DATA

Size 5-3/16" H x 12-1/2" W x 11" D

Weight 24 lbs. net, 29 lbs. shipping wt.

MOUNTING

Laboratory bench table top Secure the four bumper feet to the bottom of the unit using four 6 x 32 screws and lockwashers supplied with the power supply. Bumpers must be used to permit proper circulation of air through the unit. Removal of bumpers will restrict free flow of air, avoid removing bumpers. See figure 13 for outline drawing.

MODEL OPTIONS

Suffix "R" Fungus Proofing Option LPT-7202-FM power supplies can be obtained with fungus proofing treatment with MIL V 173 varnish for all fungi nutrient components.

Suffix "V" Option LPT-7202-FM power supplies can be obtained for 205-265 VAC, 47-440 Hz input or 187-242 VAC, 47-440 Hz input. See nameplate for AC input rating. See schematic for rewiring of AC input. For 47-53 Hz operation, derate current 10% for each ambient temperature given in table I. For 63-440 Hz operation, consult factory.

ACCESSORIES

Overvoltage Protector Externally mounted, Overvoltage Protector LHOV-4 is available for use with LPT-7202-FM supplies.

THEORY OF OPERATION

GENERAL

The text in this section refers to circuit designations of unit A of the LPT-7202 model power supply, however the discussion is equally applicable to units Band C which have similar components.

The Lambda power supply consists of an AC input circuit and transformer; a bias supply consisting of an auxiliary rectifier, filter, and preregulator*; a main regulator circuit consisting of the main rectifier, filter, a series regulator, emitter follower drivers, a current comparator*, a voltage comparator*, a voltage amplifier*, current and voltage sensing networks, a voltage reference*, and a current amplifier*.

*This circuit element is part of integrated circuit IC101.

The circuit arrangement is shown in block diagram form, figure 10. The circuitry is discussed with reference to the block diagram and the schematic diagram.

FUNCTIONAL DESCRIPTION

Single phase input power is applied to transformer T1 through the input circuit containing a thermostat and fuse F1, which protect the supply against overheating and internal faults.

The main rectifier, a full wave rectifier, provides the power which is filtered by capacitor C1 and then regulated via a series regulator and delivered to the output. Half-wave auxiliary rectifier CR101 provides voltage filtered by capacitor C101 for the preregulator located in IC101.

Constant Voltage Circuit Operation

Constant voltage developed by IC101 across R101, R102 produces a constant current of 5 milliamperes through R108, R106, and Q103B. This current is fed through dividers R1 A, B which, in turn, develop a constant reference voltage for one input to the voltage comparator. A second input, the load voltage, is compared to the reference voltage by the comparator. A change in output voltage produces an error signal at the output of the comparator. If the output voltage tends to rise, the comparator conducts, less current flows through CR104 and current to driver Q53 is reduced. This action increases the voltage across the series regulator thus reducing the output voltage.

Constant Current Operation

Constant current developed by IC101 flows through resistor R3. A reference voltage, developed at the wiper of R3 is applied at one input to the current comparator. A second input to the comparator is the voltage developed across R52. If the current to the load tends to increase, the voltage across R52 increases causing the comparator to conduct. This action reduces current to driver Q53 and increases the series regulator impedance, thus limiting the output current. The current limit value is determined by the setting of resistor R3.

OPERATING INSTRUCTIONS

CONTROLS, INSTRUMENTS, AND FUSES

Power ON—OFF Switch. The power ON—OFF switch, located on the front panel, controls application of input power to the supply. When the Switch is in the ON position, the red power on indicator glows.

OUTPUT VOLTAGE Control. The OUTPUT VOLTAGE control is a dual control consisting of a coarse adjustment potentiometer, which varies the DC voltage over a range of 0-6, 0-19, volts as applicable, and a fine adjustment potentiometer, which varies the DC voltage over a one-volt range. Clockwise rotation results in increasing voltage. The total DC voltage output for voltage regulated operation is equal to the sum of each shaft setting; for current regulated operation the maximum voltage limit is equal to the sum of each shaft setting. The controls are located on the front panel.

CURRENT LIMITER Control. The CURRENT LIMITER control varies the DC current over the rated current range*. Clockwise rotation results in increasing current. The controls are located on the front panel.

*Operation for output current below rated limits can result in no output or no regulation.

Output Voltage Meter. A DC voltmeter monitors the voltage at the output terminals over the rated voltage range.

Output Current Meter. A DC ammeter monitors the load output current over the rated current range.

Fuses. Fuse F1, internally located, is a 5 ampere, 3AG "SLO-BLO" fuse which functions in the AC input circuit.

Fuse F2 internally located is a 10 ampere, 3AG "NORM-BLO" fuse which provides protection against internal circuit failure in unit A.

Connection Terminals. Make all connections to the supply at the terminal blocks on the rear of the supply. DC output connections can also be made at the five-way binding posts located on the front panel. Apply input power through the line cord or directly to terminals 1 and 2 if the line cord is removed. Always connect the ungrounded (hot) power lead to terminal 1.

The supply positive terminals are brought out to terminal 6 (0-7 volt, unit A); terminal 14 (0-20 volt, unit B); terminal 26 (0-20 volt, unit C). The supply negative terminals are brought out to terminal 4 (0-7 volt, unit A); terminal 12 (0-20 volt, unit B); terminal 24 (0-20 volt, unit C). Recommended wiring of the power supply to the load and selection of wiring is shown in figures 1 through 9. Selection of proper wiring is made on the basis of load requirements. Make all performance checks and measurements of current or voltage at the rear output terminals. Connect measuring devices directly to sense terminals or use the shortest leads possible.

GROUND CONNECTIONS

The Lambda power supply can be operated either with negative or positive output terminal grounded or with no terminal grounded. Both positive and negative ground connections are shown in the diagrams for all suggested output connections illustrated in this manual.

NOTE: When operating the supply with neither terminal grounded high impedance leakage resistance and capacitance paths can exist between the power supply circuitry and chassis ground.

BASIC MODES OF OPERATION

This power supply is designed to operate as a constant voltage source or as a constant current source. Automatic crossover to either mode of operation occurs when load conditions change as follows:

Constant Voltage. The power supply will function as a constant voltage source while the load current does not equal the current value, I_{LIM} , set by the CURRENT LIMITER control. When load current $I_L = V/R_L = I_{LIM}$, the supply will cross over automatically and will operate as a constant current source. Further decrease in value of load resistance R_L results in a decrease of voltage across the load while current remains regulated to I_{LIM} .

Constant Current (Automatic Crossover). The power supply will function as a constant current source while the load voltage V_L does not equal the voltage value set by the OUTPUT VOLTAGE control. When load voltage V_L equals the value set by the OUTPUT VOLTAGE control, the supply will automatically cross over and operate as a constant voltage source.

SUPPLY — LOAD CONNECTIONS

NOTE: Refer to DETAILED OPERATING PROCEDURES For step-by-step instructions for operation of power supply.

CONNECTIONS FOR OPERATION AS A CONSTANT VOLTAGE SOURCE

The output impedance and regulation of the power supply at the load may change when using the supply as a constant voltage source and connecting leads of practical length are used. To minimize the effect of the output leads on these characteristics, remote sensing is used. Recommended types of supply load connections with local or remote sensing are described in the following paragraphs.

Refer to figure 1 to determine voltage drop for particular cable length, wire size and current conditions. Lead lengths must be measured from supply terminals to load terminals as shown in figure 2.

Local Sensing Connection, Figure 3. Local sensing is the connection suitable for application with relatively constant load where extremely close load regulation over full-rated current excursion is *not* required at the load and/or where short power output leads are used.

Remote Sensing Connection, Figure 4. Remote sensing provides complete compensation for the DC voltage drops in the connecting cables. A 2MF, 35V capacitor may be required to reduce noise, between terminals 3-4, 6-7, 11-12, 14-15, 23-24, and 26-27 whenever remote sensing is used. +S and -S sensing leads must be twisted together.

Programmed Voltage Connections, Using External Resistor, Figure 5. Discrete voltage steps can be programmed with a resistance voltage divider valued at 200 ohms/volt output and a shorting-type switch as shown in figure 5. When continuous voltage variations are required, use variable resistor with the same 200 ohms/volt ratio in place of the resistive voltage divider and shorting-type switch. Use a low temperature coefficient resistor to assure most stable operation.

As shown in figure 5, voltages can be programmed utilizing either local or remote sensing connections, as desired.

Programmed Voltage Connections Using Programming Voltage, Figure 6. The power supply voltage output can be programmed with an externally connected programming power supply.

The output voltage of the programmed supply will maintain a one-to-one ratio with the voltage of the programming supply.

CONNECTIONS FOR OPERATION AS A CONSTANT CURRENT SOURCE

Automatic Crossover Constant Current Connections, Figure 3. Figure 3 shows the connections which are used when operating the power supply as a constant current source with automatic crossover, using local setting of current control.*

*Setting control for output currents below rated limits can result in no output or no regulation.

In this mode of operation, when the load voltage increases, due to changing load resistance, to the limit of the OUTPUT VOLTAGE control setting, the power supply crossover circuit will cause the unit to operate as a constant voltage supply.

CONNECTIONS FOR SERIES OPERATION

The voltage capability of the LPT-7202-FM power supply can be extended by series operation of two LPT-7202-FM power supply outputs of equal* voltage ratings. A maximum of 300 volts can be connected between either the +DC or -DC terminal and chassis ground.

*For applications using supply outputs of unequal ratings, consult factory for details of operation.

The two units are shown connected for series operation in figures 7 and 8. Figure 7 shows the series connection diagram which would be suitable for use in all applications where exact one-to-one voltage tracking of the "master" (M) unit by the "slave" (S) unit is not required. The slight offset in tracking is easily compensated for by adjusting the OUTPUT VOLTAGE controls on the (S) unit.

Figure 8 shows the series connection diagram suitable for applications where exact one-to-one voltage tracking is required. In this series configuration, resistor RBAL permits the (S) unit to track the (M) unit on an exact one-to-one basis, thereby eliminating the possibility of an offset voltage existing between the two units.

Resistor R_{BAL} should be a two-watt, 10 ohm/volt output, resistor. This value would permit wide-range compensation for manufacturing differences inherent in the components used in each unit. Resistors R_S and R_M function in the voltage sensing circuits of both units, enabling the (S) unit to reference its output voltage to that of the (M) unit. In figure 7, R_M performs a similar function. Capacitor C_S , used to eliminate stray AC pickup, is rated at 2.5 mfd, 200 V.

For either series mode of operation, select R_S and R_M on the basis of 200 ohms per volt of (M) unit output voltage. R_S must equal R_M . Choose R_S and R_M to be low temperature coefficient resistors.

Diodes CR_M and CR_S , which protect the units against reverse voltage must be capable of withstanding the maximum rated current of the (M) unit, and must have a reverse blocking voltage equal to 2.5 times the maximum rated output voltage. These diodes not required for series operation of B and C units.

Both methods permit operation for either constant voltage or constant current with automatic crossover to either mode of operation whenever the respective limiting operating current or voltage is reached. As shown in figures 7 and 8, each method permits connection for either local or remote sensing.

CONNECTIONS FOR PARALLEL OPERATION

The current capability of LPT-7202 power supply can be extended by parallel operation of two LPT-7202 power supply outputs of equal* voltage capacities. The two units are shown connected for parallel operation in figure 9. One unit designated the "master" or (M) unit controls its own output as well as the output of the second unit designated the "slave" or (S) unit.

*For applications using supply outputs of unequal voltage ratings, consult factory for details of operation.

Unit (S) operates to regulate its current to be equal to that of the (M) unit by comparing the current in its internal sampling resistor with that current sampled by the master internal sampling resistor.

Parallel connected units can be operated for constant voltage with local sensing, figure 9A, or remote sensing, figure 9B, as well as for constant current with automatic crossover, figure 9A. When operating for constant voltage, the (M) unit can automatically cross over into constant current operation.

DETAILED OPERATING PROCEDURES

SAFETY NOTICE

DANGEROUS VOLTAGES EXIST IN THIS EQUIPMENT. OBSERVE THE USUAL SAFETY PRECAUTIONS WHEN OPERATING OR SERVICING THE EQUIPMENT TO AVOID SHOCK OR INJURY.

CONSTANT VOLTAGE OPERATION, ADJUSTABLE CURRENT LIMIT

1. Apply AC power to the supply but place power ON-OFF switch in OFF position.

NOTE: When shipped from the factory, the supply is ready for use as a constant current source with automatic crossover or as a local-sensing constant voltage source. Jumpers are connected at the factory as shown in figure 3. Take care to remove the appropriate jumpers for load requirements that need different supply-load connections. Refer to the appropriate connection diagram. When five way binding posts are used, do not remove barrier strip jumpers.

2. Determine load requirements, select wire size from figure 1 and 2, and choose desired type of supply-load connection from figure 3 and 4. Do not connect load.
3. Place power ON-OFF switch in ON position and check that red indicator is lit.
4. Set CURRENT LIMITER control fully CW and adjust OUTPUT VOLTAGE control knobs to obtain desired voltage indication. When the current to the load must be limited to an intermediate value within the current rating of the supply, proceed as follows: a) place power ON-OFF switch in OFF position, b) connect jumper between +V and -V terminals, c) place power ON-OFF switch in ON position and adjust CURRENT LIMITER control to obtain the desired meter indication, d) place power ON-OFF switch in OFF position and remove jumper.
5. Connect supply to load as shown on selected connection diagram.
6. Place power ON-OFF switch in ON position and check that red indicator is lit.
7. Check that output current and output voltage meters indicate desired values; as required, adjust OUTPUT VOLTAGE control knobs and CURRENT LIMITER control to obtain correct meter indications.
8. Power supply is now in proper operation.

PROGRAMMED CONSTANT VOLTAGE OPERATION, ADJUSTABLE CURRENT LIMIT

1. Apply AC power to the supply, but place power ON-OFF switch in OFF position.

NOTE: When shipped from the factory, the supply is ready for use as a constant current source with automatic crossover or as a local-sensing constant voltage source. Jumpers are connected at the factory as shown in figure 3. Take care to remove the appropriate jumpers for load requirements that need different supply-load connections. Refer to the appropriate connection diagram. When the five way binding posts are used, do not remove barrier strip jumpers.

2. Determine load requirements, select wire size and length from figures 1 and 2, and choose desired type of supply load connections from figures 5 or 6. Refer to paragraph on Programmed Voltage Connections.
3. Connect supply terminals as shown on the selected connection diagram. As shown in figure 5, take care to use a shorting-type switch for the external programming control when several voltages are desired and the programming voltage method is not used. Do not connect load.
4. When current to the load must be limited to an intermediate value within the current rating of the supply, proceed as follows:
 - a) Connect jumper between +V and -V terminals
 - b) Place power ON-OFF switch in ON position and adjust CURRENT LIMITER control to obtain the desired current limit meter indication.
 - c) Place power ON-OFF switch in OFF position and remove jumper between +V and -V terminals.
5. Connect Supply to load as shown on the selected connection diagram.
6. Place power ON-OFF switch in ON position and check that red power-on indicator is lit.
7. Check that output current and output voltage meters indicate desired values; as required, adjust CURRENT LIMITER knob and external programming voltage control to obtain correct meter indications.
8. Power supply is now operating properly.

CONSTANT CURRENT OPERATION WITH CROSSOVER, ADJUSTABLE VOLTAGE LIMIT

1. Apply AC power to the supply, but place power ON-OFF switch in OFF position.

NOTE: When shipped from factory, the supply is ready for use as a constant current source with automatic crossover or as a local-sensing constant voltage source. Jumpers are connected at the factory as shown in figure 3. Take care to remove the appropriate jumpers for load requirements that need different supply-load connections. Refer to the appropriate connection diagram. When the five way binding posts are used, do not remove barrier strip jumpers.

2. Determine load requirements, select wire size from figures 1 and 2, and connect supply terminals as shown in figure 3. Do not connect load.
3. Adjust CURRENT LIMIT control to the desired output current as follows:
 - a) Connect jumper between +V and -V terminals.
 - b) Place power ON-OFF switch in ON position and adjust CURRENT LIMITER control to obtain the desired load current as indicated on current meter.
 - c) Place power ON-OFF switch in OFF position and remove jumper between +V and -V terminals.
4. Place power ON-OFF switch in ON position and adjust OUTPUT VOLTAGE control knobs to obtain the desired voltage limit point as indicated on voltage meter.
5. Place power ON-OFF switch in OFF position and connect load to the supply as shown in figure 3.
6. Place power ON-OFF switch in ON position and check that red power-on indicator is lit.
7. Check that output current and output voltage meters indicate desired values; adjust OUTPUT VOLTAGE control knobs and CURRENT LIMITER control as required to obtain correct indications.
8. Power supply is now in proper operation.

***SERIES CONNECTION CONSTANT VOLTAGE OPERATION, WITH CURRENT LIMIT**

1. Apply AC power input to the supply, but place power ON-OFF switch in OFF position.

NOTE: When shipped from the factory, the supply is ready for use as a constant current source with automatic crossover or as a local-sensing constant voltage source. Jumpers are connected at the factory as shown in figure 3. Take care to remove the appropriate jumpers for load requirements that need different supply-load connections. Refer to the appropriate connection diagram. When the five way binding posts are used, do not remove barrier strip jumpers.

2. Determine load requirements, select wire size from figures 1 and 2 choose correct type of series supply-load connections from figures 7 and 8. Refer to paragraph on CONNECTIONS FOR SERIES OPERATION.
3. Connect power supply terminals as shown on the selected connection diagram. As required, select resistors R_{BAL} , R_S , and R_M and diodes CR_S and CR_M in accordance with instructions contained in CONNECTIONS FOR SERIES OPERATION. Do not connect load.
- 4.**Place power ON-OFF switch in ON position and adjust OUTPUT VOLTAGE control knobs on the (M) unit to obtain the desired meter indication. Adjust (S) unit OUTPUT VOLTAGE controls until (S) unit voltage meter indication equals (M) unit voltage meter indication. This setting will be approximately one-half of the combined (M) and (S) unit output voltage. The (S) unit will track any change in (M) unit output voltage made with the (M) unit OUTPUT VOLTAGE control. Place power ON-OFF switch in OFF position.
5. When current to the load must be limited to an intermediate value within the current rating of each supply, proceed as follows:
 - a) Connect jumpers between +V and -V terminals on the (M) unit.
 - b) Place power ON-OFF switch in ON position and adjust CURRENT LIMITER control on the (M) unit to the desired current limit point, as indicated on current meter.

*Applies only to units of equal voltage and current capacities, when units of unequal ratings are series connected, consult factory.

**This step does not apply to figure 8.

- c) Set CURRENT LIMITER control on (S) unit slightly above CURRENT LIMITER control setting on (M) unit.
- d) Place power ON-OFF switch in OFF position and remove jumpers between +V and -V terminals.
6. Connect supply to load as shown on the selected connection diagram.
7. Place power ON-OFF switch in ON Position and check that red power-on indicator is lit.
8. Check that output current and output voltage meters indicate desired values: adjust OUTPUT VOLTAGE control knobs and CURRENT LIMITER control as required to obtain correct indications.
9. Power supplies are now in proper operation.

SERIES CONNECTION CONSTANT CURRENT OPERATION, WITH VOLTAGE LIMIT

1. Apply AC power input to the supply, but place power ON-OFF switch in OFF position.

NOTE: When shipped from the factory, the supply is ready for use as a constant current source with automatic crossover or as a local-sensing constant voltage source. Jumpers are connected at the factory as shown in figure 3. Take care to remove the appropriate jumpers for load requirements that need different supply-load connections. Refer to the appropriate connection diagram. When the five way binding posts are used, do not remove barrier strip jumpers.

2. Determine load requirements, select wire size from figures 1 and 2 and choose correct type of series supply-load connections from figures 7A and 8A. Refer to paragraph on CONNECTIONS FOR SERIES OPERATION.
3. Connect power supply terminals as shown on the selected connection diagram. As required, select resistors R_{BAL} , R_S , and R_M and diodes CR_S and CR_M as instructed in CONNECTIONS FOR SERIES OPERATION. Do not connect load.
4. Place power ON-OFF switch in ON position.
5. Adjust (S) unit OUTPUT VOLTAGE controls until (S) unit voltage meter indication equals (M) unit voltage meter indication. The (S) unit will track any change in (M) unit output voltage made with the (M) unit OUTPUT VOLTAGE control.
6. When the voltage to the load must be limited to an intermediate value within the voltage rating of the series combination, proceed as follows:
 - a) Place power ON-OFF switch in ON position.
 - b) Turn the (M) unit OUTPUT VOLTAGE control knobs until voltage meter indicates approximately one-half the total rating desired for the series combination.
 - c) Place power ON-OFF switch in OFF position.
7. Adjust CURRENT LIMITER control for the desired load current as follows:
 - a) Connect jumpers between +V and -V terminals on (M) unit.
 - b) Place power ON-OFF switch in ON position and adjust CURRENT LIMITER control to the desired load current as indicated on (M) unit current meter.
 - c) Set CURRENT LIMITER control on (S) unit slightly above CURRENT LIMITER control setting on (M) unit.
 - d) Place power ON-OFF switch in OFF position and remove jumpers between +V and -V terminals.
8. Connect supplies to load as shown on the selected connection diagram.
9. Place power ON-OFF switch in ON position and check that red power-on indicator is lit.
10. Check that output current and output voltage meters indicate desired values; adjust OUTPUT VOLTAGE control knobs and CURRENT LIMITER control as required to obtain correct indications.
11. Power supplies are now in proper operation.

PARALLEL CONNECTION CONSTANT VOLTAGE OPERATION, WITH CURRENT LIMIT

1. Apply AC power input to the supply, but place power ON-OFF switch in OFF position.

NOTE: When shipped from the factory the supply is ready for use as a constant current source with automatic crossover or as a local-sensing constant voltage source. Jumpers are connected at the factory as shown in figure 3. Take care to remove the appropriate jumpers for load requirements that need different supply-load connections. Refer to the appropriate connection diagram. When the five way binding posts are used, do not remove barrier strip jumpers.

2. Determine load requirements, select wire size from figures 1 and 2 and choose correct type of parallel supply-load connections from figures 9A and 9B. Connect supply terminals as shown on the selected connection diagram, but do not connect load.
3. Place power ON-OFF switch in ON position.
4. Turn (M) and (S) unit CURRENT LIMITER controls fully CW.
5. Adjust (M) unit OUTPUT VOLTAGE control for the desired voltage as read on (M) unit voltage meter.
6. Place power ON-OFF switch in OFF position.
7. When current to the load must be limited to an intermediate value within the current rating of each unit, proceed as follows:
 - a) Connect supply to the load and place a jumper across load terminals.
 - b) Place power ON-OFF switch in ON position and adjust (M) unit CURRENT LIMITER control for desired meter reading. The short circuit current will be the sum of (M) & (S) unit current meter readings.
 - c) Place power ON-OFF switch in OFF position and remove jumper across load.
8. Place power ON-OFF switch in ON position and check that red power-on indicator is lit.
9. Check that output current and output voltage meters indicate desired values; adjust OUTPUT VOLTAGE control knobs and CURRENT LIMITER control as required to obtain correction indications.
10. Power supplies are now in proper operation.

PARALLEL CONNECTION CONSTANT CURRENT OPERATION, WITH VOLTAGE LIMIT

1. Apply AC power input to the supply, but place power ON-OFF switch in OFF position.

NOTE: When shipped from the factory, the supply is ready for use as a constant current source with automatic crossover or as a local-sensing constant voltage source. Jumpers are connected at the factory as shown in figure 3. Take care to remove the appropriate jumpers for load requirements that need different supply-load connections. Refer to the appropriate connection diagram. When the five way binding posts are used, do not remove barrier strip jumpers.

2. Determine load requirements, select wire size from figures 1 and 2, and choose correct type of parallel supply-load connections from figure 9A. Connect supply terminals as shown on the selected connection diagram, but do not connect load.
3. Place power ON-OFF switch in ON position.
4. Turn (S) unit current limiter control fully CW.

5. Adjust (M) unit OUTPUT VOLTAGE control for the desired voltage limit point as read on (M) unit voltage meter.
6. Place power ON-OFF switch in OFF position.
7. Set the desired load current as follows:
 - a) Connect supply to the load and place a jumper across load terminals.
 - b) Place power ON-OFF switch in ON position and adjust (M) unit CURRENT LIMITER control for desired meter reading. The regulated current will be the sum of (M) and (S) unit current meter readings.
 - c) Place power ON-OFF switch in OFF position and remove jumper across load.
8. Place power ON-OFF switch in ON position and check that red power-on indicator is lit.
9. Check that output current and output voltage meters indicate desired values; adjust OUTPUT VOLTAGE control knobs and CURRENT LIMITER control as required to obtain correct indications.
10. Power supplies are now in proper operation.

OPERATION AFTER PROTECTIVE DEVICE SHUTDOWN

Thermostat Shutdown

The thermostat opens the input circuit only when the temperature of the transistor heat radiator exceeds a maximum safe value. The thermostat will automatically reset when the temperature of the radiator decreases to safe operation value. After eliminating the cause(s) for overheating and allowing time for the power supply to cool to a proper temperature, resume operation of the supply. Refer to appropriate operation paragraph in DETAILED OPERATING PROCEDURES.

Fuse Shutdown

Internal component failure is prevented by fuses which protect the components from damage caused by excessive currents. Fuses will blow when the maximum rated current value for the fuse is exceeded. Fatigue failure of fuses can occur when mechanical vibrations from the installation combine with thermally induced stresses to weaken the fuse metal. Many fuse failures are caused by a temporary condition, and replacing the blown fuse will make the fuse protected circuit operative.

MAINTENANCE

GENERAL

This section describes trouble analysis routine, replacement procedures, calibration and test procedures that are useful for servicing the Lambda power supply. A trouble chart is provided as an aid for the troubleshooter. Refer to the section on SPECIFICATIONS AND FEATURES for the minimum performance standards.

TROUBLE ANALYSIS

Whenever trouble occurs, systematically check all fuses, primary power lines, external circuit elements, and external wiring for malfunction before trouble shooting the equipment. Failures and malfunctions often can be traced to simple causes such as improper jumper and supply-load connections or fuse failure due to metal fatigue.

Use the electrical schematic diagram and block diagram, figure 10, as an aid to locating trouble causes. The schematic diagram contains various circuit voltages that are averages for normal operation. Measure these voltages using the conditions for measurement specified on the schematic diagram. Use measuring probes carefully to avoid causing short circuits and damaging circuit components.

CHECKING TRANSISTORS AND CAPACITORS

Check transistors with an instrument that has a highly limited current capability. Observe proper polarity for PNP or NPN to avoid error in measurement. The forward transistor resistance is low but never zero; backward resistance is always higher than the forward resistance.

For good transistors, the forward resistance for any junction is always greater than zero.

Do not assume trouble is eliminated when only one part is replaced. This is especially true when one transistor fails, causing other transistors to fail. Replacing only one transistor and turning power on, before checking for additional defective components could damage the replaced component.

When soldering semi-conductor devices, wherever possible, hold the lead being soldered with a pair of pliers placed between the component and the solder joint to provide an effective heat sink.

NOTE: The leakage resistance obtained from a simple resistance check of a capacitor is not always an indication of a faulty capacitor. In all cases the capacitors are shunted with resistances, some of which have low values. Only a dead short is a true indication of a shorted capacitor.

PRINTED CIRCUIT BOARD MAINTENANCE TECHNIQUES

1. If foil is intact but not covered with solder, it is a good contact. Do not attempt to cover with solder.
2. Voltage measurements can be made from either side of the board. Use a needle-point probe to penetrate to the wiring whenever a protective coating is used on the wiring. A brass probe can be soldered to an alligator clip adapted to the measuring instrument.
3. Wherever possible, use a heat sink when soldering transistors.
4. Broken or damaged printed wiring is usually the result of an imperfection, strain, or careless soldering. To repair small breaks, tin a short piece of hook-up wire to bridge the break, and holding the wire in place, flow solder along the length of wire so that it becomes part of the circuitry.
5. When unsoldering components from the board, never pry or force loose the part; unsolder the component by using the wicking process described below:
 - a) Select a 3/16 inch tinned copper braid for use as a wick; if braid is not available, select AWG No. 14 or No. 16 stranded wire with 1/2 inch insulation removed.
 - b) Dip the wick in liquid rosin flux.
 - c) Place the wick onto the soldered connection and apply soldering iron onto the wick.
 - d) When sufficient amount of solder flows onto the wick, freeing the component, simultaneously remove iron and wick.

TROUBLE CHART

The trouble chart is intended as a guide for locating trouble causes, and is used along with the schematic diagram. The trouble chart refers to circuit designations of unit A, however the chart is equally applicable to units B & C which have similar components.

The operating conditions assumed for the trouble chart are as follows:

- a) AC power of proper voltage and frequency is present at input terminals.
- b) Either positive or negative terminal is connected to chassis ground.
- c) The power supply is connected for constant voltage with local sensing. See schematic; dotted lines indicate jumpers connected for local sensing operation.

TROUBLE SHOOTING CHART

<u>Symptom</u>	<u>Possible Cause</u>	<u>Remedy</u>
1. Zero volts DC output	OUTPUT VOLTAGE controls turned fully CCW.	Check OUTPUT VOLTAGE controls for proper setting and correct as necessary.
	CURRENT LIMITER control turned fully CCW.	Check CURRENT LIMITER for proper setting & correct as necessary.
	Short circuit across output of supply.	Check load and load connections, correct as necessary.
	F1 and/or F2 open	Replace F1 or F2; if it blows immediately, check for shorted transistors Q1 or Q2 & capacitors C4 & C10, replace as necessary.
	R60, R61, and/or R66 open (unit B only)	Check for shorted transistors Q4, Q5 and capacitors C5, C11. Replace defective components
	R70, R71, and/or R76 open (unit C only)	Check for shorted transistors Q6, Q7 and capacitors C6, C12. Replace defective components.
	Series regulator section open.	Check Q1, Q2 for open, replace as necessary.
	Open CR3	Check CR3 for open; replace as necessary.
	Open CR104.	Check CR104 for open, replace as necessary.
	Open Q103.	Check Q103 for open & replace as necessary.
Current sensing resistor open.	Check R52 for open, R3 for short; replace as necessary.	
Jumpers between terms 10-9 and 7-6 open.	Check supply terminal connections; correct as necessary.	

<u>Symptom</u>	<u>Possible Cause</u>	<u>Remedy</u>
	Aux. rectifier CR101 open.	Check CR101 for open; replace as necessary.
2. Unable to adjust	Damaged OUTPUT VOLTAGE controls.	Check R1A, and B for short or open; replace as necessary.
	Jumper between terms 4-3 open	Check supply terminal connections; correct as necessary.
3. High ripple at twice line frequency and unregulated DC output.	Series regulator transistors shorted.	Check Q1, Q2, for short and replace as necessary.
4. High ripple at twice line frequency	Open C1.	Check C1 for open, replace as necessary.
5. High ripple at line frequency.	Defective main rectifier.	Check for open in CR1, CR2.
6. Same as 3, except intermittent.	Foreign matter fallen into unit.	Check for loose bench hardware and wire chippings that may have fallen through cover.
7. High ripple at frequency other than line or twice line frequency.	Oscillation due to defective component in filter network.	Check for open C4, C102, C10 and check for open and/or short in C106 & R114. Replace defective component.
8. Large spikes at output.	Capacitors C8, C9 open.	Replace C8, C9 as necessary.

ADJUSTMENT OF VOLTAGE CALIBRATION CONTROLS R108, R208, R308

The adjustment procedure requires that the power supply is removed from associated equipment is at an ambient temperature of 25-30°C and is operated at nominal line voltage, no load.

Whenever R1A, R1B, R106, R108, Q103 or IC101 are replaced and voltage indications do not reflect maximum ratings, adjust R108 as follows. Whenever R6A, R6B, R206, Q203, or IC201 are replaced and voltage indications do not reflect maximum ratings adjust R208 as follows. Wherever R8A, R8B, R306, Q303, or IC301 are replaced and voltage indications do not reflect maximum ratings, adjust R308 as follows.

1. Apply AC power to the supply and place power ON-OFF switch in OFF position.
2. Break seal on wiper of R108, R208, or R308 from resistor housing.
3. Place power ON-OFF switch in ON Position.
4. Turn OUTPUT VOLTAGE controls fully CW.

5. Adjust R108, R208, or R308 until maximum output voltage is reached (as indicated on voltage meter). If better than 2% accuracy is required, connect a DVM (John Fluke Model 891A or equivalent) at supply output terminals to measure output voltage.
6. Place power ON-OFF switch in OFF position.
7. After adjustment is completed, remove AC power input to the supply and reseal wiper of R108, R208, or R308 to potentiometer housing.

ADJUSTMENT OF CURRENT CALIBRATION CONTROL R102, R202, R302

The adjustment procedure requires that the power supply is removed from associated equipment is at an ambient temperature of 25-30°C and is operated at nominal line voltage.

Whenever IC101, R3, R101, R102 or R52 are replaced, and current indications do not reflect maximum ratings, adjust R102 as follows. Whenever IC201, R4, R201, R202, or R66 are replaced, and current indications do not reflect maximum ratings, adjust R202 as follows. Whenever IC301, R5, R301, R302, or R76 are replaced, and current indications do not reflect maximum ratings, adjust R302 as follows.

1. Apply AC power to the supply and place power ON-OFF switch in OFF position.
2. Unsolder wiper of R102, R202, or R302 from resistor housing and set at midpoint position.
3. Place a jumper between +V and -V terminals.
4. Turn CURRENT LIMITER control fully CW.
5. Place power ON-OFF switch on ON position.
6. Adjust R102, R202, or R302 until output current (as read on current meter) is 105% of rating for the supply. Refer to table I for maximum current ratings.
7. Place power ON-OFF switch in OFF position.
8. After adjustment is completed, remove AC power input to the supply and solder wiper of R102, R202, or R302 to resistor housing.

PERFORMANCE CHECKS

Checks With Constant Voltage Operation

Check the ripple and regulation of the power supply using the test connection diagram shown in figure 11. Use suggested test equipment or equivalent to obtain accurate results. Refer to SPECIFICATIONS AND FEATURES for minimum performance standards.

Set the differential meter, DC DVM (John Fluke Model 891A or equivalent) to the selected power supply operating voltage. Check the power supply load regulation accuracy while switching from the load to no-load condition. Long load leads should be a twisted pair to minimize AC pick-up.

Use a Variac to vary the line voltage from 105-132 or 132-105 volts AC and check the power-supply line regulation accuracy on the differential meter.

Use a VTVM, Ballantine 320 or equivalent, to measure rms ripple voltage of the power supply DC output. Use oscilloscope to measure peak-to-peak ripple voltage of the power supply DC output.

Checks with Constant Current Operation

Check the ripple or regulation of the power supply using the test connection diagram shown in figure 12. Refer to SPECIFICATIONS AND FEATURES for minimum performance standards.

Check the power supply load regulation accuracy while switching from the short circuit to load condition. Measure the voltage across sensing resistor R_s . Use John Fluke Model 891A or equivalent for the DVM connected across R_s . For R_s use a resistor having the same value as resistor R52 (or as applicable R66 or R76) in the unit being tested. To obtain regulation figure substitute values obtained into regulation formula:

$$\frac{\Delta E}{R_s} = \text{Regulation in milliamperes,}$$

where ΔE is the voltage change in millivolts and R_s is the resistance of the sensing resistor.

Use a Variac to vary the line voltage from 105-132 or 132-105 volts AC and check the power supply line regulation accuracy using the VTVM and the regulation formula:

$$\frac{\Delta E}{R_s}$$

SERVICE

When additional instructions are required or repair service is desired, contact the nearest Lambda office where trained personnel and complete facilities are ready to assist you.

Please include the power supply model and serial number together with complete details of the problem. On receipt of this information Lambda will supply service data or advise shipping for factory repair service.

All repairs not covered by the warranty will be billed at cost and an estimate forwarded for approval before work is started.

PARTS ORDERING

Standard components and special components used in the Lambda power supply can be obtained from the factory. In case of emergency, critical spare parts are available through any Lambda office.

The following information must be included when ordering parts:

1. Model number and serial number of power supply and purchase date.
2. Lambda part number.
3. Description of part together with circuit designation.
4. If part is not an electronic part, or is not listed, provide a description, function and location of the part.

PARTS LIST

The electrical parts located on Lambda LPT-7202-FM are listed here. In addition, there are separate listings of parts for the "V" option and LHOV-4 accessory.

MODEL LPT-7202-FM

CIRC. DESIG.	DESCRIPTION	LAMBDA NO.
C1	Cap., elect., 16,000 mf -10 + 100%, 30 vdc	CBT-16-040
C2,	Cap., elect., 3,900 mf	CBS-39-070
C3	-10 + 100%, 45 vdc	
C4	Cap., elect., 460 mf -10 + 100%, 20 vdc	CBR-46-064
C5,	Cap., elect., 140 mf	CBR-14-062
C6	-10 + 100%, 40 vdc	
C7	Cap., mylar, 0.033 mf +10%, 400 vdc	CGL-33-006
C8	Cap., mylar, 0.1 mf +10%, 200 vdc	CAM-10-012
thru C12		
C13	Not assigned	
thru C49		
C50	Cap., mylar, 0.001 mf +10%, 200 vdc	CGK-10-004
C51	Not assigned	
thru C59		
C60	Same as C50	
C61	Not assigned	
thru C65		
C66,	Same as C8	
C67		
C68,	Not assigned	
C69		
C70	Same as C50	
C71	Not assigned	
thru C75		
C76,	Same as C8	
C77		
C101	Cap., elect., 100 mf -10 + 75%, 35 vdc	CBR-10-108
C102	Cap., mylar, 0.047 mf +10%, 200 vdc	CGL-47-018
C103,	Not assigned	
C104		
C105	Same as C8	
C106	Same as C50	
C107	Cap., elect., 3 mf -10 + 75%, 100 vdc	CBN-30-015
C201	Same as C101	
C202	Same as C102	
C203,	Not assigned	
C204		
C205	Same as C8	
C206	Same as C50	
C207	Same as C107	
C301	Same as C101	
C302	Same as C102	
C303,	Not assigned	
C304		
C305	Same as C8	
C306	Same as C50	
C307	Same as C107	
CR1	Rectifier	FBL-00-054
thru CR3		

MODEL LPT-7202-FM (Cont.)

CIRC. DESIG.	DESCRIPTION	LAMBDA NO.
CR4,	Rectifier	FBL-00-094
CR5		
CR6	Not assigned	
thru CR62		
CR63	Rectifier	FBL-00-047
thru CR65		
CR66	Not assigned	
thru CR72		
CR73	Same as CR63	
thru CR75		
CR101	Rectifier	FBL-00-096
CR102,	Not assigned	
CR103		
CR104	Same as CR101	
CR105	Not assigned	
CR106,	Same as CR101	
CR107		
CR108	Rectifier, zener diode	FBM-Z119
CR109	Not assigned	
thru CR123		
CR124	Rectifier, zener diode	FBM-Z139
CR201	Same as CR101	
CR202,	Not assigned	
CR203		
CR204	Same as CR101	
CR205	Not assigned	
CR206,	Same as CR101	
CR207		
CR208	Same as CR108	
CR209	Not assigned	
thru CR223		
CR224	Same as CR124	
CR301	Same as CR101	
CR302,	Not assigned	
CR303		
CR304	Same as CR101	
CR305	Not assigned	
CR306,	Same as CR101	
CR307		
CR308	Same as CR108	
CR309	Not assigned	
thru CR323		
CR324	Same as CR124	
DS1	Pilot light	HRD-00-013
F1	Fuse, 5A, 3AG, SLO-BLO	FFC-05-000
F2	Fuse, 10A, 3AG, NORM-BLO	FFB-10-000
IC101,**	Integrated circuit	FBT-00-031
IC201,		
IC301		
M1	Voltmeter, 0-10 vdc	EBP-10-040
M2,	Voltmeter, 0-20 vdc	EBP-20-041
M3		

**IC101, IC201 and IC301 was FBT-00-034
on units with Serial no. prefixes A & B.

MODEL LPT-7202-FM (Cont.)

CIRC. DESIG.	DESCRIPTION	LAMBDA NO.
M4	Ammeter, 0-5 adc	EDN-50-037
M5	Ammeter, 0-1.5 adc	EDN-15-035
M6		
Q1	Transistor, NPN	FBN-L157
thru		
Q3		
Q4	Transistor, NPN	FBN-L156
thru		
Q7		
Q8	Not assigned	
thru		
Q52		
Q53	Transistor, NPN	FBN-L109
Q54	Not assigned	
thru		
Q66		
Q67,	Same as Q53	
Q68		
Q69	Not assigned	
thru		
Q76		
Q77,	Same as Q53	
Q78		
Q101,	Not assigned	
Q102		
Q103	Transistor, dual complimentary	FBN-L182
Q201,	Not assigned	
Q202		
Q203	Same as Q103	
Q301,	Not assigned	
Q302		
Q303	Same as Q103	
R1	Res., dual, var., ww, 1,300 ohms $\pm 5\%$, 2w/200 $\pm 5\%$, 2w	DNS-15-082
R2	Not assigned	
R3	Res., var., ww, 500 ohms $\pm 5\%$, 5w	DNR-50-013
thru		
R5		
R6	Res., dual, var., ww, 3,800 ohms $\pm 5\%$, 2w/200 ohms $\pm 5\%$, 2w	DNS-40-061
R7	Not assigned	
R8	Same as R6	
R9	Not assigned	
thru		
R49		
R50,	Res., ww, 0.22 ohm $\pm 5\%$, 5w	DFM-22-045
R51		
R52	Res., ww, 0.1 ohm $\pm 5\%$, 5w	DFM-10-074
R53	Res., ww, 600 ohms $\pm 3\%$, 3w	DFR-60-005
R54	Res., comp., 100 ohms $\pm 10\%$, $\frac{1}{2}w$	DEB-1011
R55	Res., comp., 560 ohms $\pm 10\%$, $\frac{1}{2}w$	DEB-5611
R56	Not assigned	
thru		
R59		
R60	Res., ww, 1 ohm $\pm 3\%$, 3w	DFN-10-041
R61		
R62	Res., comp., 6,800 ohms $\pm 10\%$, $\frac{1}{2}w$	DEB-6821
R63	Res., ww, 750 ohms $\pm 3\%$, 3w	DFR-75-085
R64	Same as R54	
R65	Same as R55	
R66	Res., ww, 0.17 ohm $\pm 5\%$, 3w	DFM-17-052

MODEL LPT-7202-FM (Cont.)

CIRC. DESIG.	DESCRIPTION	LAMBDA NO.
R67	Not assigned	
thru		
R69		
R70,	Same as R60	
R71		
R72	Same as R62	
R73	Same as R63	
R74	Same as R64	
R75	Same as R65	
R76	Same as R66	
R101	Res., film, 8,870 ohms $\pm 1\%$, $\frac{1}{4}w$	DCS-89-073
R102	Res., var., ww, 10,000 ohms $\pm 10\%$, $\frac{1}{2}w$	DNT-10-009
R103	Res., comp., 2,200 ohms $\pm 10\%$, $\frac{1}{2}w$	DEB-2221
R104,	Not assigned	
R105		
R106	Res., ww, 1,200 ohms $\pm 3\%$, 2w	DFS-12-030
R107	Not assigned	
R108	Res., var., cermet, 1,200 ohms $\pm 20\%$, 1w	DRS-12-014
R109	Res., comp., 36,000 ohms $\pm 5\%$, $\frac{1}{2}w$	DEB-3635
R110	Not assigned	
R111	Res., film, 430 ohms $\pm 5\%$, $\frac{1}{4}w$	DCR-43-047
R112	Res., comp., 22,000 ohms $\pm 10\%$, $\frac{1}{2}w$	DEB-2231
R113	Res., film, 390 ohms $\pm 5\%$, $\frac{1}{4}w$	DCR-39-004
R114	Res., comp., 100 ohms $\pm 10\%$, $\frac{1}{4}w$	DCB-1011
R115	Not assigned	
thru		
R118		
R119	Res., comp., 4,700 ohms $\pm 10\%$, $\frac{1}{4}w$	DCB-4721
R120	Res., comp., 6,800 ohms $\pm 5\%$, $\frac{1}{4}w$	DCB-6825
R121	Res., comp., 18,000 ohms $\pm 10\%$, $\frac{1}{4}w$	DCB-1831
R123	Res., comp., 1,200 ohms $\pm 10\%$, $\frac{1}{4}w$	DCB-1221
R124	Res., comp., 22 megohms $\pm 10\%$, $\frac{1}{4}w$	DCB-2261
R201	Same as R101	
R202	Same as R102	
R203	Not assigned	
thru		
R205		
R206	Same as R106	
R207	Not assigned	
R208	Same as R108	
R209	Same as R109	
R210,	Not assigned	
R211		
R212	Same as R112	
R213	Same as R54	
R214	Same as R114	
R215	Not assigned	
thru		
R218		
R219	Same as R119	
R220	Same as R120	
R221	Same as R121	
R222	Not assigned	
R223	Res., comp., 1,000 ohms $\pm 10\%$, $\frac{1}{4}w$	DCB-1021

MODEL LPT-7202-FM (Cont.)

CIRC. DESIG.	DESCRIPTION	LAMBDA NO.
R224	Same as R124	
R301	Same as R101	
R302	Same as R102	
R303	Not assigned	
thru		
R305		
R306	Same as R106	
R307	Not assigned	
R308	Same as R108	
R309	Same as R109	
R310,	Not assigned	
R311		
R312	Same as R112	
R313	Same as R54	
R314	Same as R114	
R315	Not assigned	
thru		
R318		
R319	Same as R119	
R320	Same as R120	
R321	Same as R121	
R322	Not assigned	
R323	Same as R223	
R324	Same as R124	
S1	Switch, SPST	FDA-11-040
S2	Thermostat	FKA-137-014
T1*	Transformer	ABA-LPT-1A
XF1,	Fuseholder	HRM-00-009
XF2		

* On units with serial no. prefix A, T1 is ABA-LPT-1.

PARTS FOR "V" OPTION

On model LPT-7202-FM with suffix "V" capacitor C7, fuse F1, and transformer T1 change; and a resistor R46 is added in series with DS1. Part no. changes for C7, F1, R46, and T1 are listed here.

C7	Cap., paper, 0.01 mf ± 10%, 1000 vdc	CAL-10-021
F1	Fuse, 3A, 3AB, SLO-BLO	FFG-03-000
R46	Res., comp., 120,000 ohms ± 10%, ½w	DEB-1241
T1	Transformer	ABA-LPT-1G

PARTS FOR OVERVOLTAGE

PROTECTOR ACCESSORY MODEL

LHOV-4

C1	Cap., mylar, 0.01 mf ± 20%, 80 vdc	CGL-10-008
Q1	Transistor, NPN	FBN-L102
Q2	Transistor, PNP	FBN-L114
R1	Res., var., ww or cermet, 10,000 ohms ± 10%, ¼ w	DNT-10-045
R2	Res., film, 560 ohms + 2%, ½w	DCR-56-002
R3	Res., film, 200 ohms + 5%, ½w	DCR-20-010
R4	Res., thermistor, 425 ohms ± 5%, 1¼w	DKR-43-004
R5,	Res., comp., 1,200 ohms	DEB-1221
R6	+ 10%, ½w	
R7	Res., comp., 33 ohms ± 5%, ¼w	DCB-3305

PARTS FOR OVERVOLTAGE
PROTECTOR ACCESSORY MODEL

LHOV-4 (Cont.)

CIRC. DESIG.	DESCRIPTION	LAMBDA NO.
R8	Res., comp., 15,000 + 10%, ½w	DEB-1531
R9	Res., comp., 22 ohms + 10%, ½w	DEB-2201
R10	Same as R5	
SCR1	Rectifier, silicon controlled	FBP-00-009

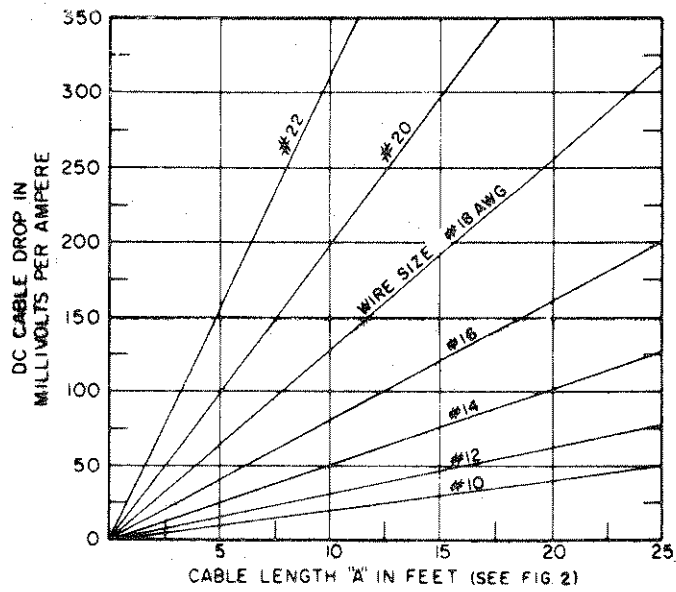

Figure 1. Cable Connection Chart

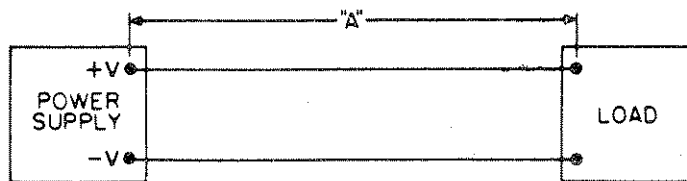
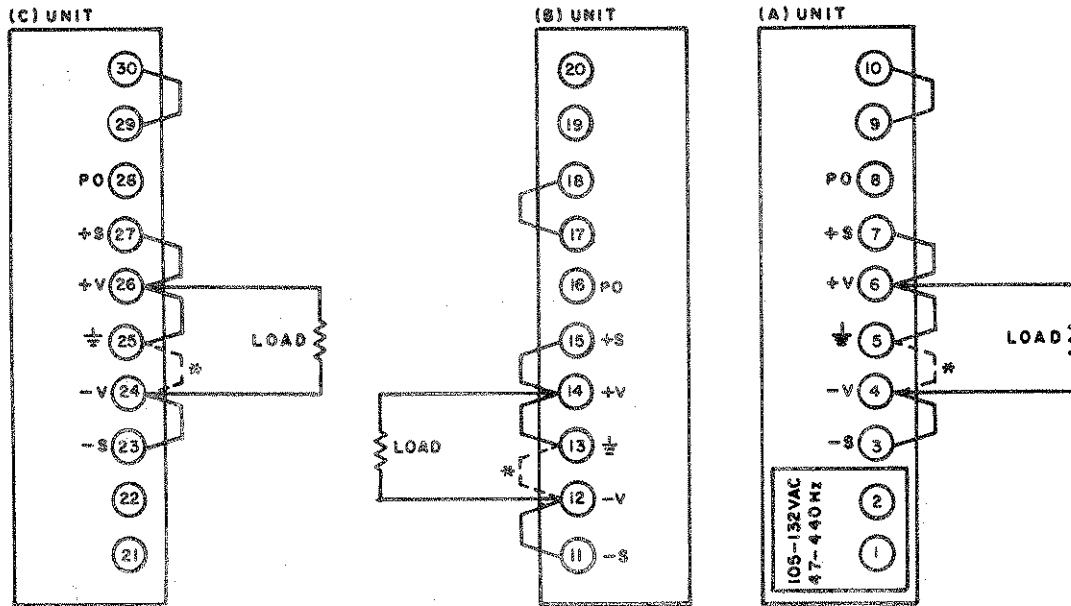
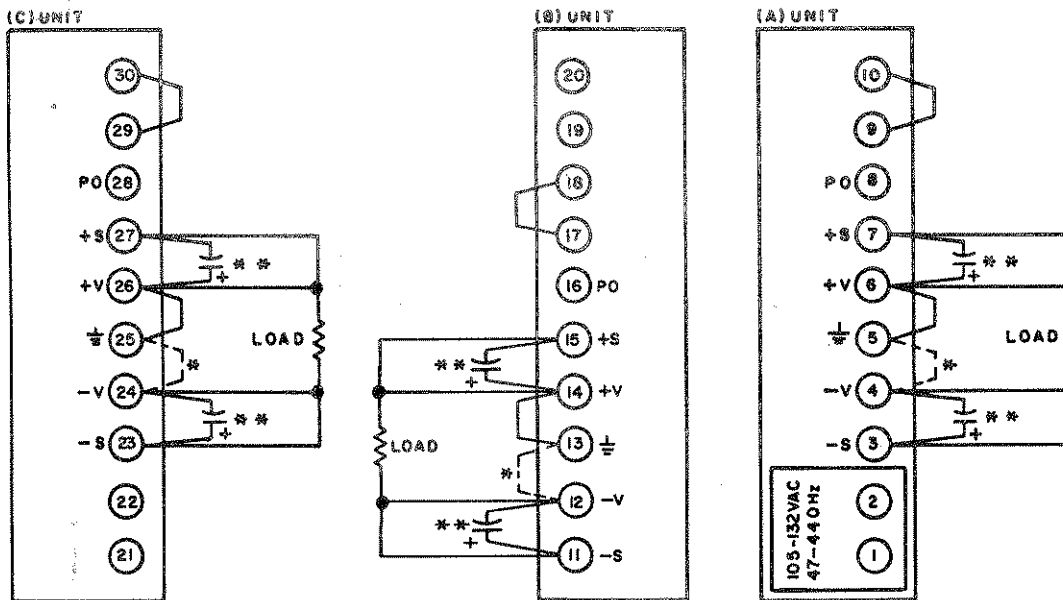

Figure 2. Cable Length "A" in Feet.



NOTE:
 * FOR NEGATIVE GROUND DISCONNECT JUMPERS FROM TERMINALS 5-6, 13-14, 25-26 AND RECONNECT TO TERMINALS 4-5, 12-13, 24-25.

Figure 3. Local Sensing Connection.



NOTE:
 * FOR NEGATIVE GROUND DISCONNECT JUMPERS FROM TERMINALS 5-6, 13-14, 25-26 AND RECONNECT TO TERMINALS 4-5, 12-13, 24-25.
 ** 2MF, 35V, ELECT. CAPACITOR MAY BE REQUIRED TO ELIMINATE NOISE PICK UP.

Figure 4. Remote Sensing Connection.

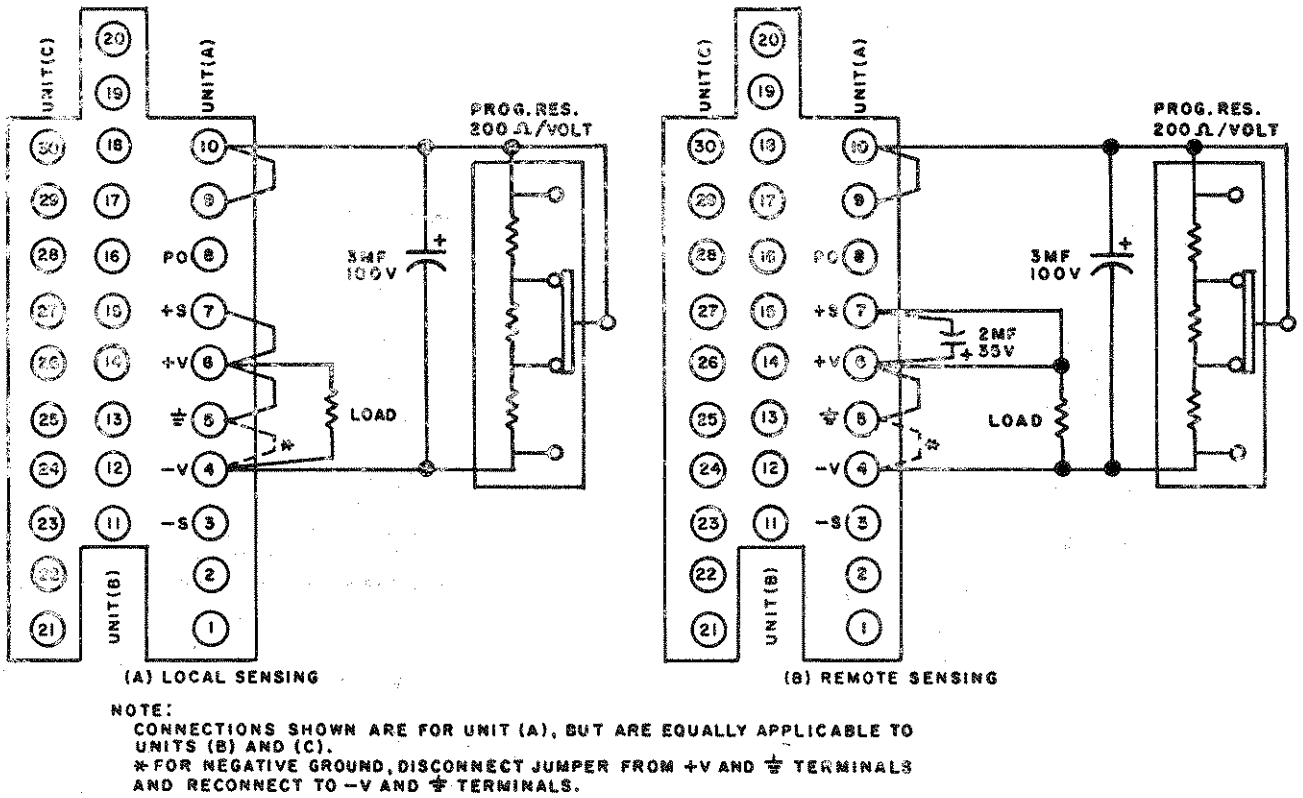

Figure 5. Programmed Voltage, With External Resistor.

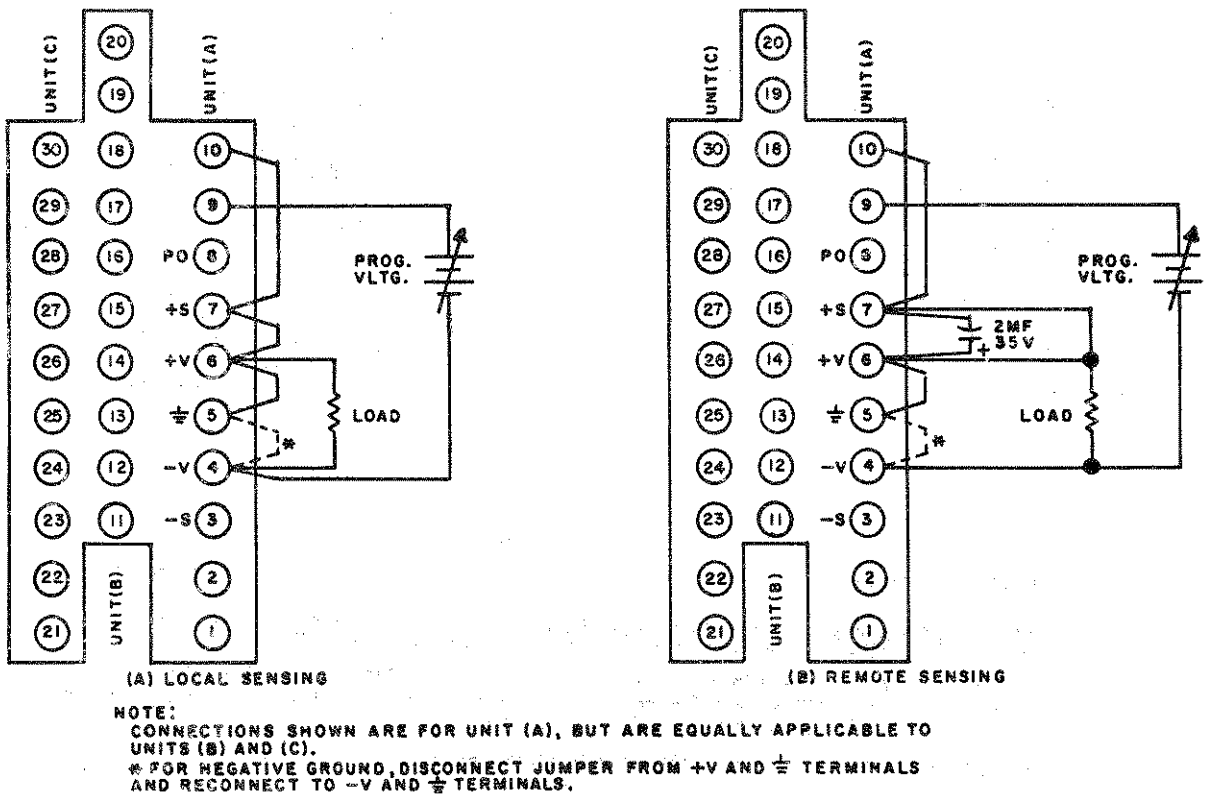
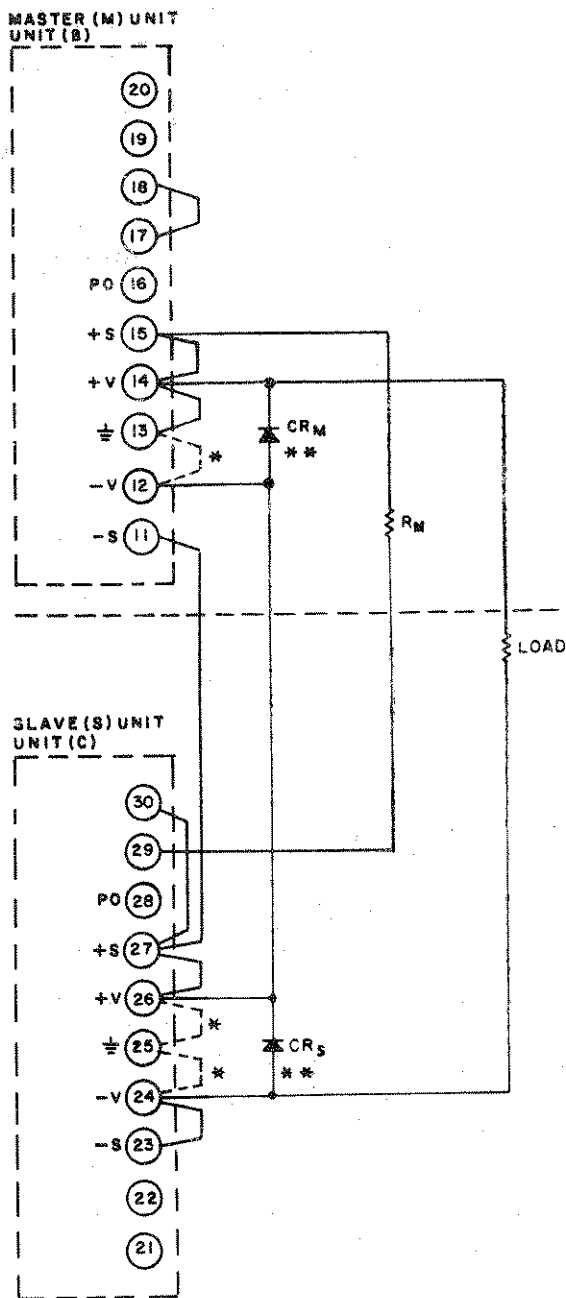
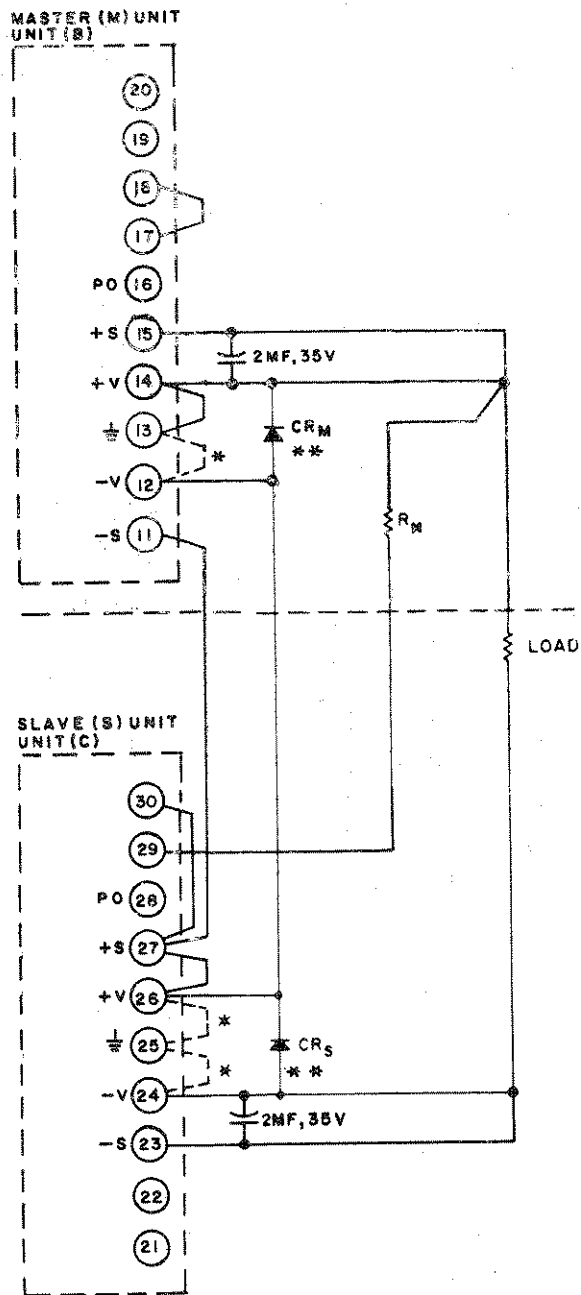

Figure 6. Programmed Voltage, With External Programming Voltage Source.



(A) LOCAL SENSING



(B) REMOTE SENSING

NOTE:

CONNECTION SHOWN IS FOR SERIES OPERATION OF (B) AND (C) UNITS. THIS CONNECTION MAY ALSO BE USED FOR THE (A) UNITS OF TWO LPT-7202-FM POWER SUPPLIES.

* MAKE ONLY ONE GROUND CONNECTION FOR THE SERIES COMBINATION; TO CHANGE GROUND AS SHOWN, REMOVE JUMPER FROM TERMINALS +V AND \oplus ON (M) UNIT AND CONNECT ANY ONE OF THE OTHER JUMPERS AS SHOWN IN DOTTED LINE.

** CR_M AND CR_S ARE NOT REQUIRED FOR SERIES OPERATION OF UNITS (B) AND (C).

Figure 7. Series Connection.

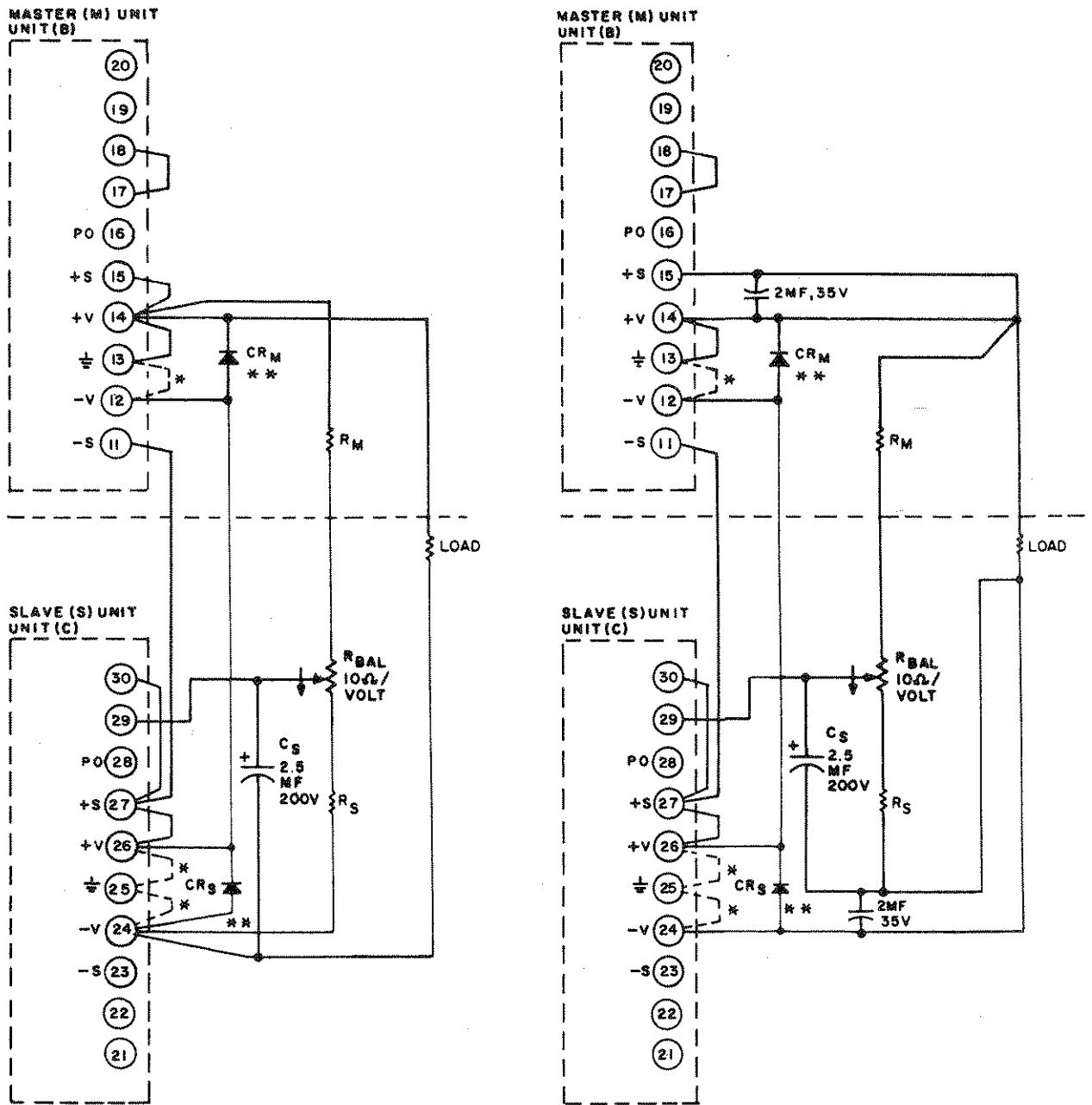

(A) LOCAL SENSING

(B) REMOTE SENSING

NOTE:
CONNECTION SHOWN IS FOR SERIES OPERATION OF (B) AND (C) UNITS. THIS CONNECTION MAY ALSO BE USED FOR THE (A) UNITS OF TWO LPT-7202-FM POWER SUPPLIES.

* MAKE ONLY ONE GROUND CONNECTION FOR THE SERIES COMBINATION; TO CHANGE GROUND AS SHOWN, REMOVE JUMPER FROM TERMINALS +V AND $\bar{\phi}$ ON (M) UNIT AND CONNECT ANY ONE OF THE OTHER JUMPERS AS SHOWN IN DOTTED LINE.

** CR_M AND CR_S ARE NOT REQUIRED FOR SERIES OPERATION OF UNITS (B) AND (C).

Figure 8. Alternate Series Connection.

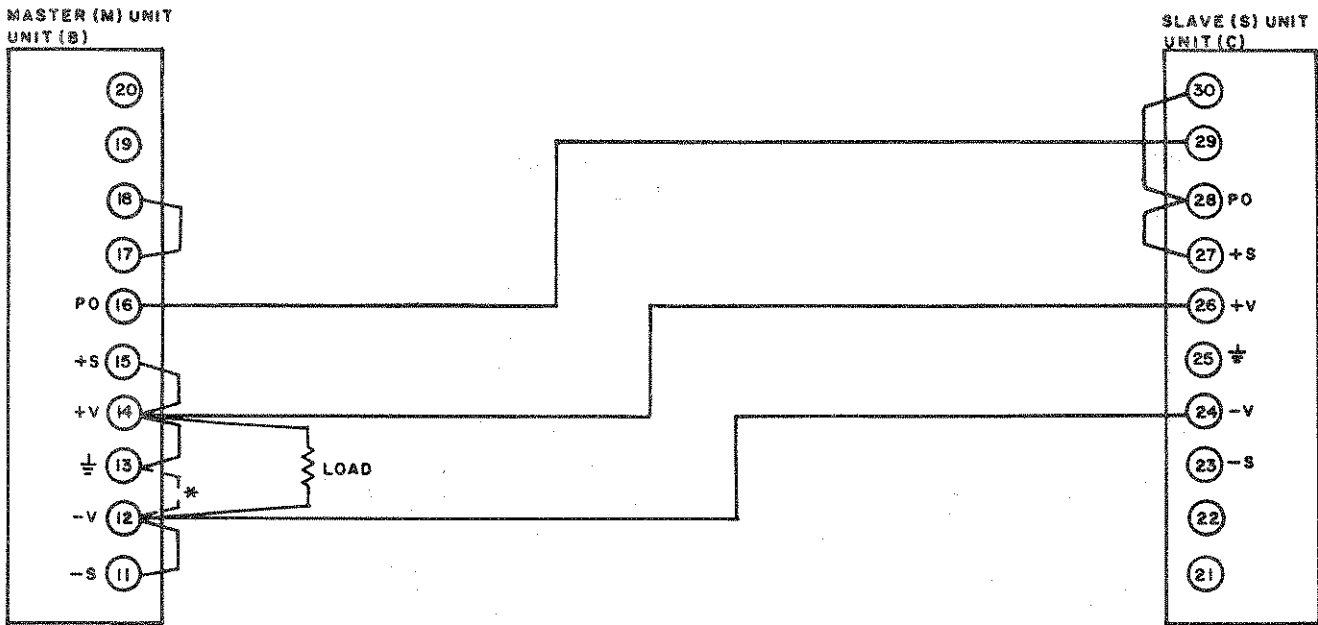

(A) LOCAL SENSING

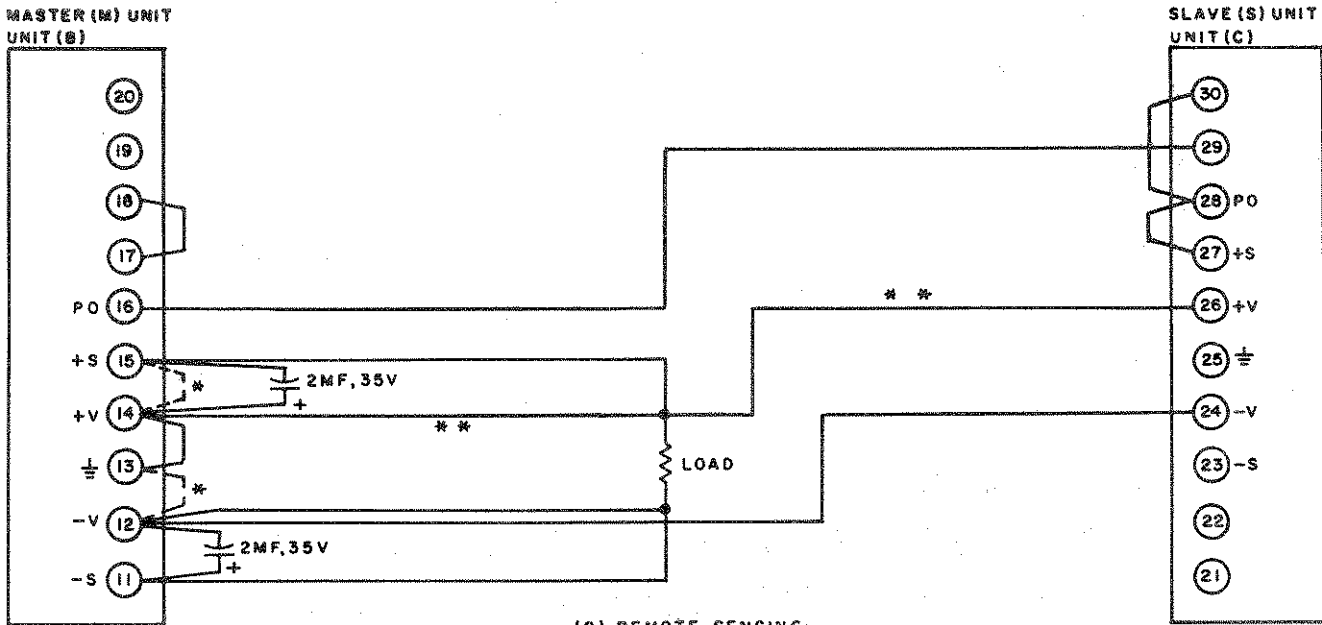

(B) REMOTE SENSING

NOTE:
 CONNECTIONS SHOWN ARE FOR PARALLEL OPERATION OF (B) AND (C) UNITS. THIS CONNECTION MAY ALSO BE USED FOR THE (A) UNITS OF TWO LPT-7202-FM POWER SUPPLIES.
 * FOR NEGATIVE GROUND, DISCONNECT JUMPER FROM +V AND \perp TERMINALS AND RECONNECT TO -V AND \perp TERMINALS.
 ** LEAD LENGTHS MUST BE EQUAL.

Figure 9. Parallel Connection.

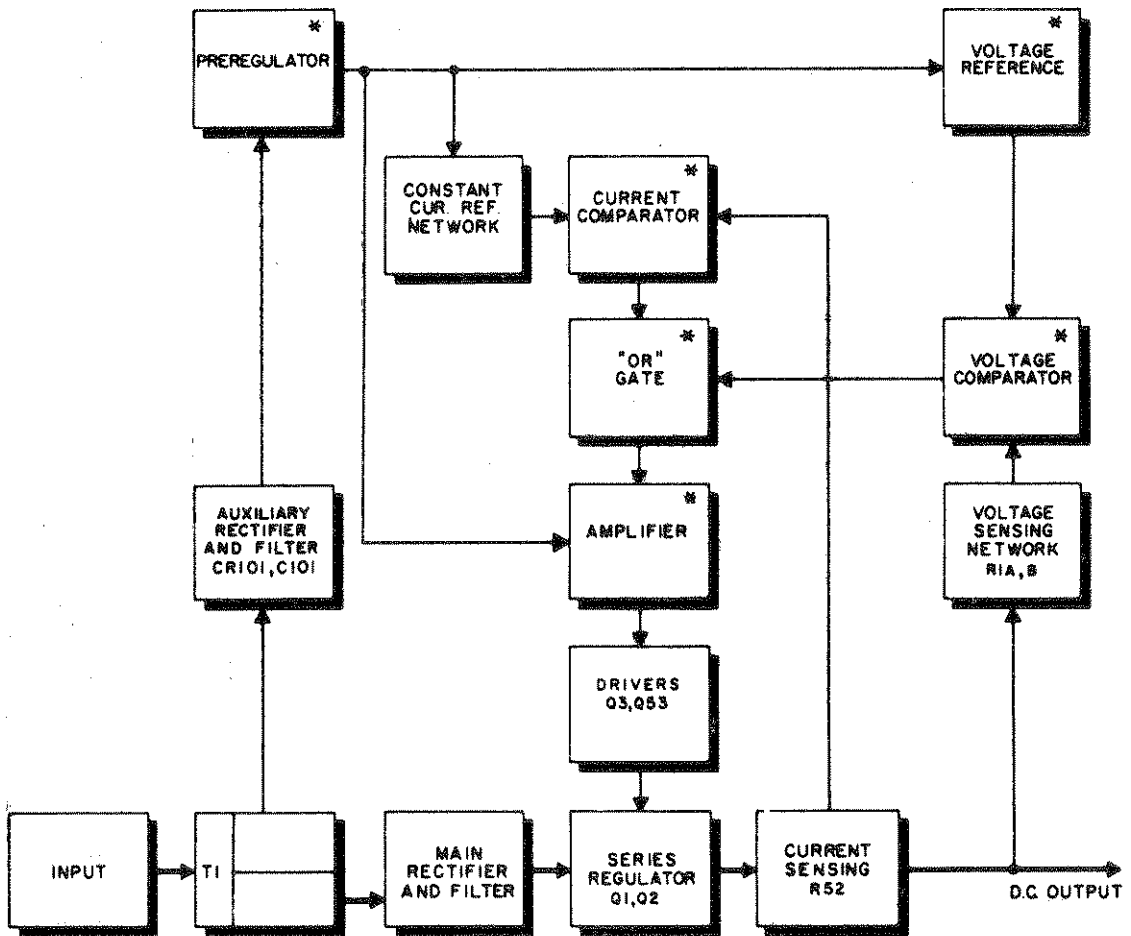

* THIS CIRCUIT ELEMENT IS LOCATED IN IC101.
 DIAGRAM SHOWN REFERS TO CIRCUIT DESIGNATIONS OF UNIT (A), HOWEVER IT IS EQUALLY APPLICABLE TO UNITS (B) AND (C) WHICH HAVE SIMILAR COMPONENTS.

Figure 10. Typical Block Diagram.

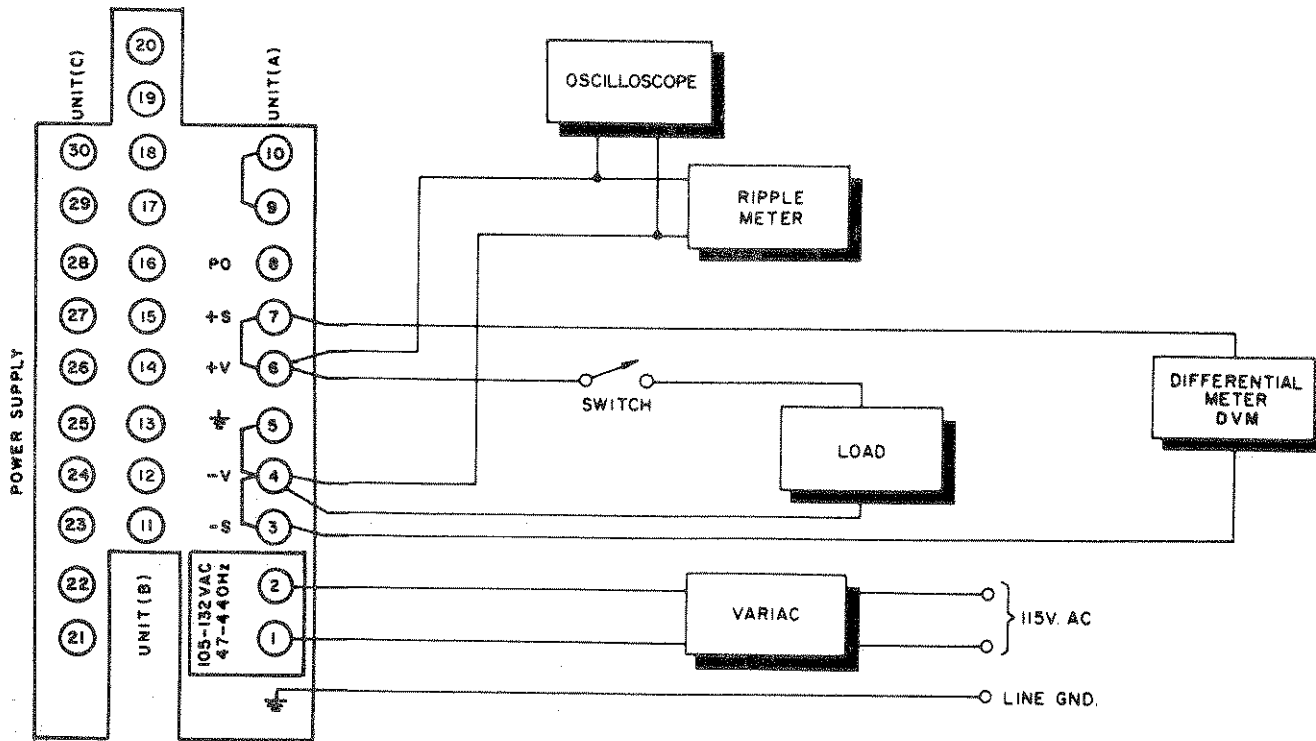

NOTES

1. REGULATION AND RIPPLE CHECK METERS MUST NOT BE GROUNDED THROUGH THREE-WIRE LINE CORD TO GROUND.
2. PERFORM CHECKS WITH LOCAL SENSING CONNECTIONS ONLY.
3. CONNECTIONS SHOWN ARE FOR UNIT (A), BUT ARE EQUALLY APPLICABLE TO UNITS (B) AND (C). AC INPUT ALWAYS CONNECTS TO TERMINALS 1 AND 2.

Figure 11. Test Connections For Constant Voltage Performance Checks.

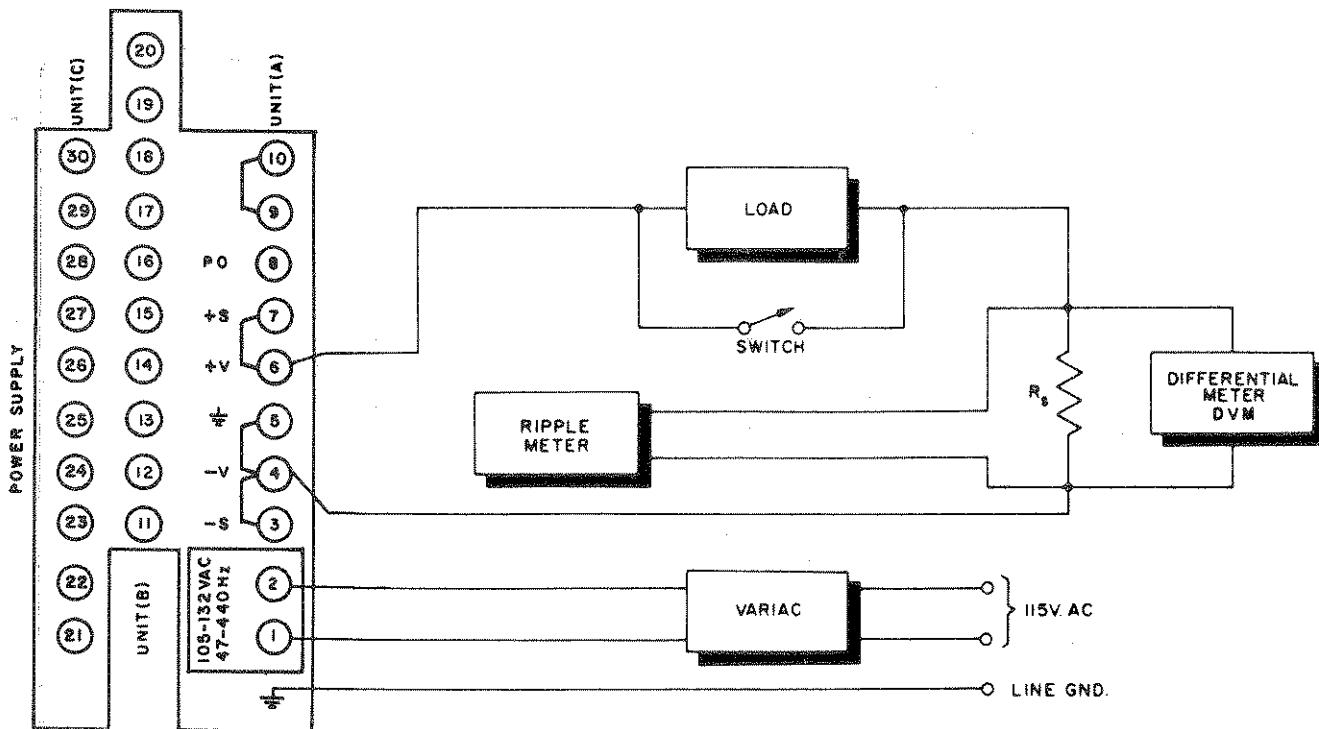

NOTES:

1. REGULATION AND RIPPLE CHECK METERS MUST NOT BE GROUNDED THROUGH THREE-WIRE LINE CORD TO GROUND.
2. PERFORM CHECKS WITH LOCAL SENSING CONNECTIONS ONLY.
3. CONNECTIONS SHOWN ARE FOR UNIT (A), BUT ARE EQUALLY APPLICABLE TO UNITS (B) AND (C). AC INPUT ALWAYS CONNECTS TO TERMINALS 1 AND 2.

Figure 12. Test Connections For Constant Current Performance Checks.

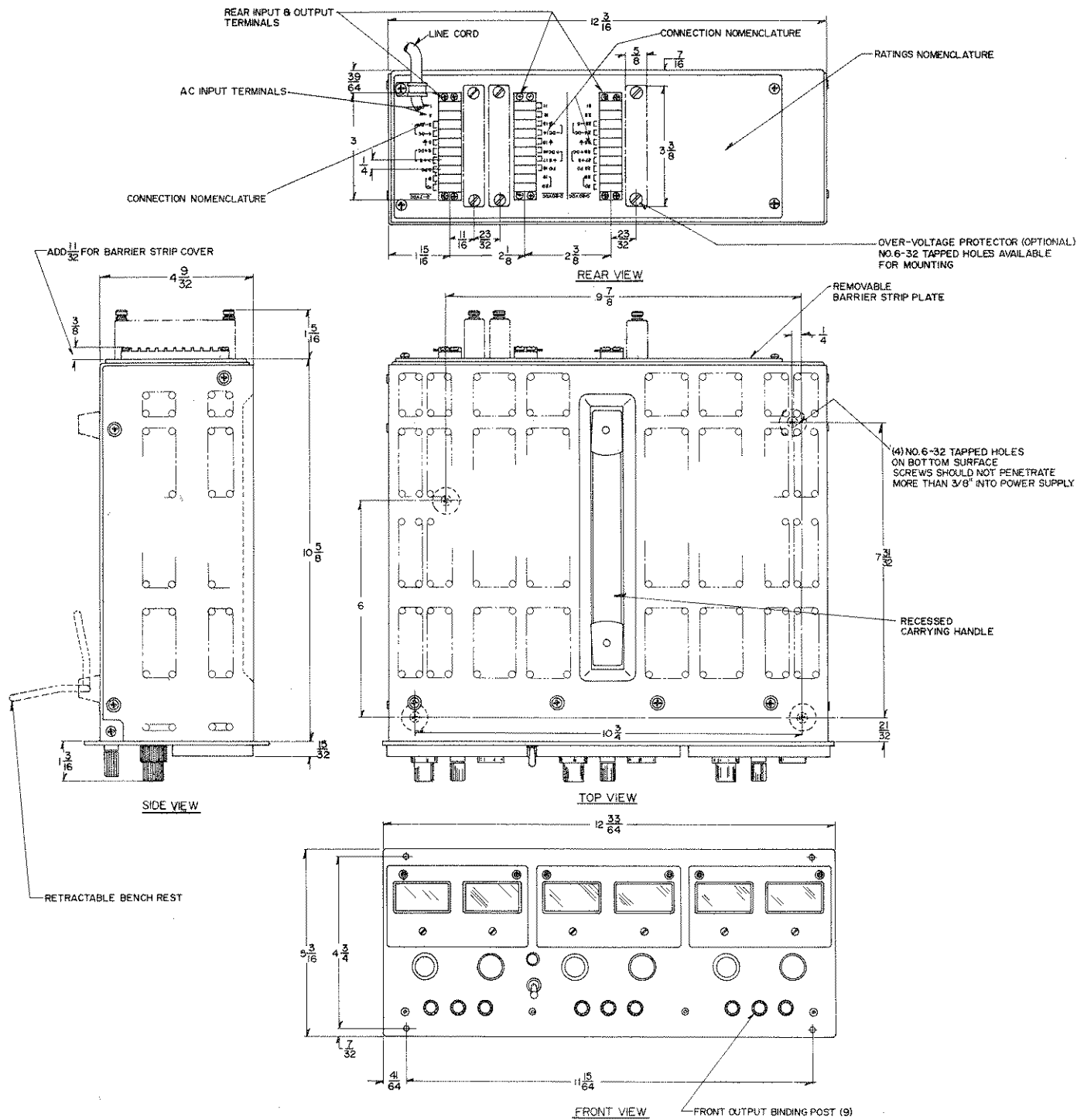
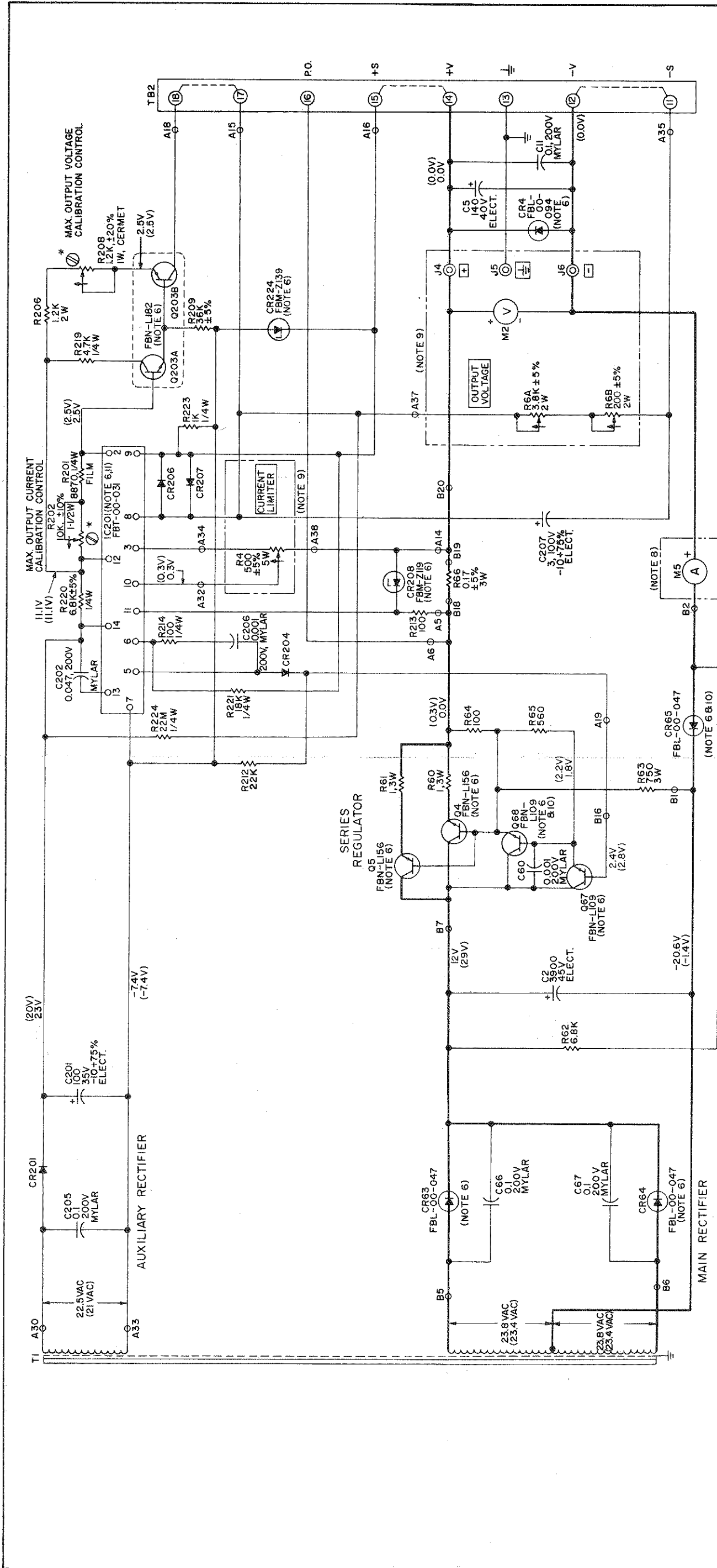

Figure 13. Outline Drawing



- NOTES
- RESISTORS ARE 1/2W COMP. WITH VALUES IN OHMS UNLESS OTHERWISE NOTED. CAPACITOR VALUES ARE IN MICROFARDS.
 - RESISTOR WATTAGE 1/2 WATT; RESISTORS ABOVE 1 WATT ARE WIRE WOUND UNLESS OTHERWISE NOTED.
 - RESISTOR TOLERANCES; COMPOSITION ±10%; WIRE WOUND ±3%; FILM ±1%, UNLESS OTHERWISE NOTED.
 - CAPACITOR TOLERANCES; ELECTROLYTIC -10%, +100%; MYLAR ±10%; UNLESS OTHERWISE NOTED.
 - SYMBOLS:
 - ↓ INDICATES CLOCKWISE ROTATION OF SHAFT.
 - ⇕ INDICATES CONNECTION TO CHASSIS.
 - ⊗ INDICATES ADJUSTMENT OR CALIBRATION CONTROL.
 - INDICATES ACTUAL UNIT MARKING.
 - * SEE INSTRUCTION MANUAL.

- LAMBDA PT. NO. FBL-00-096; USE IN 4002 DIODE FOR REPLACEMENT UNLESS OTHERWISE NOTED.
- INDICATES TERMINAL ON PRINTED WIRING BOARD.
- DESIGNATIONS ARE LAMBDA PART NUMBERS FOR OPERATION AT 47-53HZ, DERATE CURRENT 10% FOR OPERATION AT 65-440 HZ, CONSULT FACTORY.
- CONDITIONS FOR CIRCUIT POINT MEASUREMENTS, INPUT: 230V AC, 60 HZ ARE TYPICAL VALUES AND ARE UNLESS OTHERWISE NOTED. DC MEASUREMENTS TAKEN WITH 20,000 OHMS/V VOLTMETER BETWEEN TS (TERMINAL 7) & INDICATED POINTS UNLESS OTHERWISE NOTED.
 - A. CONSTANT VOLTAGE
 - B. READ NOS. NOT IN PARENTHESIS
 - C. OUTPUT: MAX RATED VOLTAGE, ZERO CURRENT.
 - D. READ NOS. IN PARENTHESIS
 - E. OUTPUT: 0 VOLTS, MAX RATED CURRENT (SHORT CIRCUIT)

- INDICATES FRONT PANEL MOUNTED COMPONENT.
- WHEN REPLACING CR65 OR Q68, RETAIN RADIATOR AND INSTALL WITH NEW PART.
- IC 201 WAS FBT-00-034 ON UNITS WITH SERIAL NO. PREFIXES A B B.

UNIT B
SCHEMATIC DIAGRAM
REGULATED POWER SUPPLY
MODEL
LPT-7202-FM
O-20 VDC OUTPUT

FOR WIRING OF POWER SUPPLY TO LOAD REFER TO SUPPLY-TO-LOAD WIRING DIAGRAMS.
DOTTED CONNECTIONS SHOWN ON TBI INDICATE JUMPERS IN PLACE FOR LOCAL SENSING CONNECTION.

THIS SCHEMATIC APPLIES TO UNITS BEARING SERIAL NO. PREFIXES A-C

LAMBDA
ELECTRONICS
MELVILLE, NEW YORK
DIVISION OF Veeco INSTRUMENTS INC.

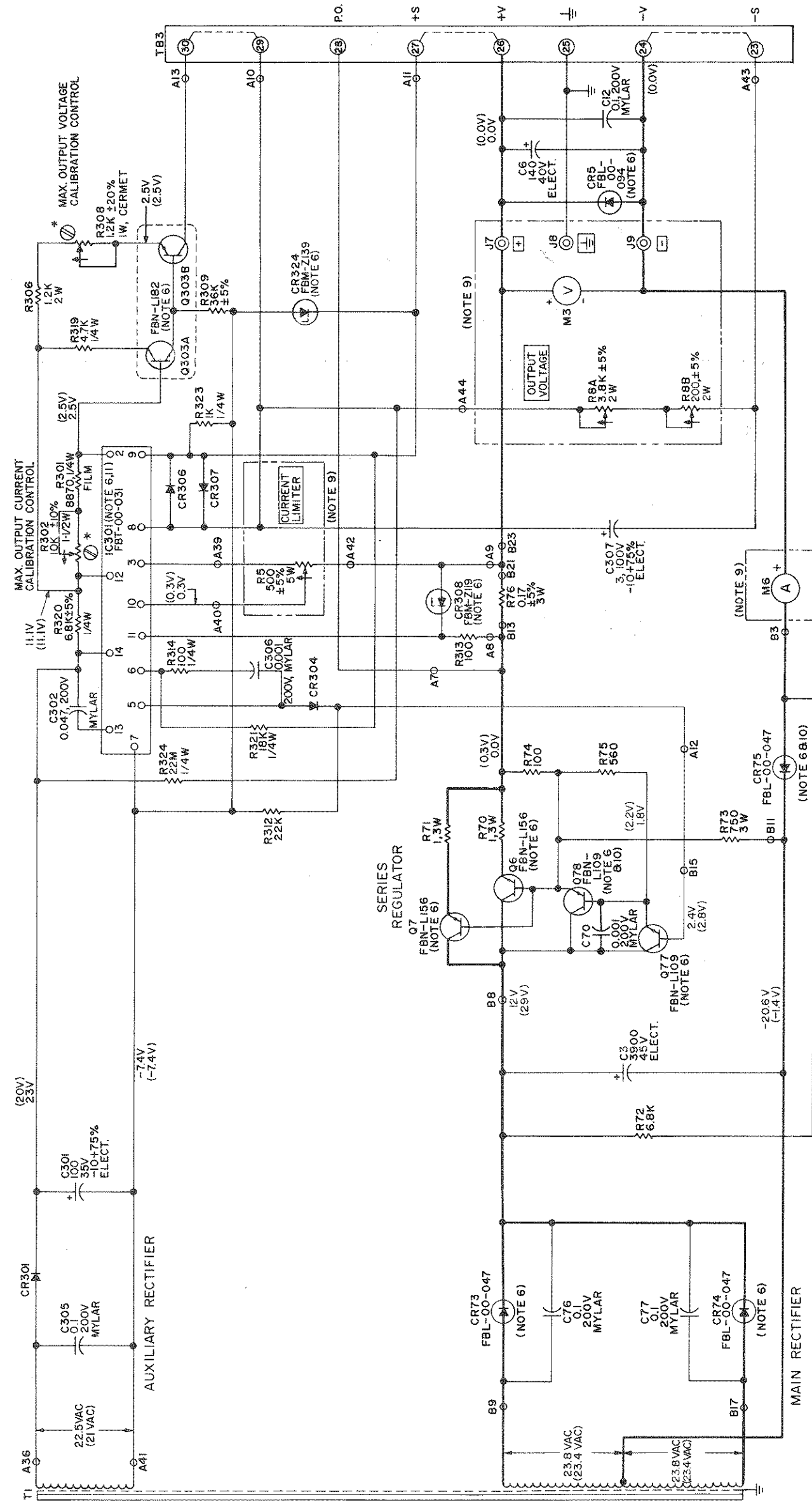

- NOTES
- RESISTORS ARE 1/2W COMP. WITH VALUES IN OHMS UNLESS OTHERWISE NOTED. CAPACITOR VALUES ARE IN MICROFARDS.
 - RESISTOR WATTAGE 1/2 WATT; RESISTORS ABOVE 1 WATT ARE WIREWOUND UNLESS OTHERWISE NOTED.
 - RESISTOR TOLERANCES; COMPOSITION $\pm 10\%$; WIREWOUND $\pm 3\%$; FILM $\pm 1\%$; UNLESS OTHERWISE NOTED.
 - CAPACITOR TOLERANCES: ELECTROLYTIC -10% , $+100\%$; MYLAR $\pm 10\%$; UNLESS OTHERWISE NOTED.
 - SYMBOLS:
 - ↓ INDICATES CLOCKWISE ROTATION OF SHAFT.
 - ⊕ INDICATES CONNECTION TO CHASSIS.
 - ⊖ INDICATES ADJUSTMENT OR CALIBRATION CONTROL.
 - ⊗ INDICATES ACTUAL UNIT MARKING.
 - * SEE INSTRUCTION MANUAL.

- LAMBDA PT. NO. FBL-00-096; USE IN 4002 DIODE FOR REPLACEMENT UNLESS OTHERWISE NOTED.
- INDICATES TERMINAL ON PRINTED WIRING BOARD.
- DESIGNATIONS ARE LAMBDA PART NUMBERS
- FOR OPERATION AT 47-53 Hz, DERATE CURRENT 10% . FOR OPERATION AT 63-440 Hz, CONSULT FACTORY.
- DC MEASUREMENTS ARE TAKEN WITH 20,000 OHMS/V UNLESS OTHERWISE NOTED.
- CONDITIONS FOR CIRCUIT POINT MEASUREMENTS, CV AND CC
 - A. CONSTANT VOLTAGE.
 - B. READ NOS. NOT IN PARENTHESIS.
 - C. OUTPUT: MAX. RATED VOLTAGE, ZERO CURRENT.
 - D. READ NOS. IN PARENTHESIS.
 - E. OUTPUT: 0 VOLTS, MAX. RATED CURRENT (SHORT CIRCUIT)

- INDICATES FRONT PANEL MOUNTED COMPONENT.
- WHEN REPLACING CR75 OR Q78, RETAIN RADIATOR AND INSTALL WITH NEW PART.
- IC 301 WAS FBT-00-034 ON UNITS WITH SERIAL NO. PREFIXES A & B.

FOR WIRING OF POWER SUPPLY TO LOAD REFER TO SUPPLY-TO-LOAD WIRING DIAGRAMS. DOTTED CONNECTIONS SHOWN ON TBI INDICATE JUMPERS IN PLACE FOR LOCAL SENSING CONNECTION.

UNIT C
SCHEMATIC DIAGRAM
REGULATED POWER SUPPLY
MODEL
LPT-7202-FM
0-20 VDC OUTPUT

LAMBDA
ELECTRONICS
MELVILLE, NEW YORK
DIVISION OF **Veeco** INSTRUMENTS INC.

THIS SCHEMATIC APPLIES TO UNITS BEARING SERIAL NO. PREFIXES A-C

