

OPERATOR'S MANUAL

BOP (M) (D) 100W, 200W, 400W BIPOLAR POWER SUPPLY

100W: BOP 20-5, BOP 50-2, BOP 100-1

200W: BOP 20-10, BOP 36-6, BOP 50-4, BOP 72-3, BOP 100-2, BOP 200-1

400W: BOP 20-20, BOP 36-12, BOP 50-8, BOP 72-6, BOP 100-4

KEPCO INC.
An ISO 9001 Company.

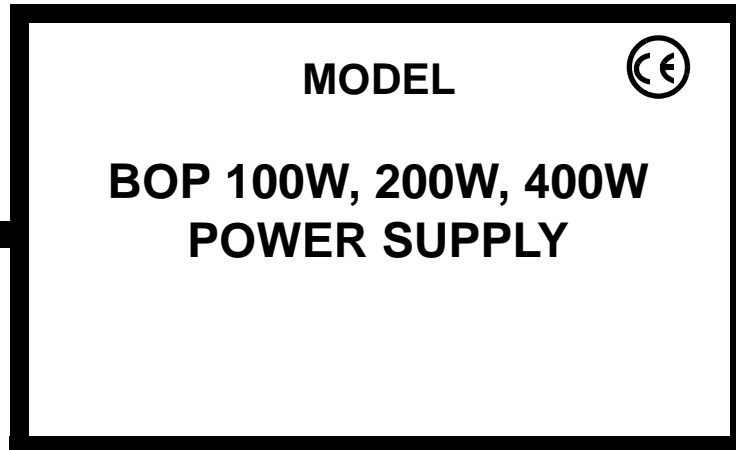

IMPORTANT NOTES:

- 1) This manual is valid for the following Model and associated serial numbers:

MODEL	SERIAL NO.	REV. NO.
-------	------------	----------

- 2) A Change Page may be included at the end of the manual. All applicable changes and revision number changes are documented with reference to the equipment serial numbers. Before using this Instruction Manual, check your equipment serial number to identify your model. If in doubt, contact your nearest Kepco Representative, or the Kepco Documentation Office in New York, (718) 461-7000, requesting the correct revision for your particular model and serial number.
- 3) The contents of this manual are protected by copyright. Reproduction of any part can be made only with the specific written permission of Kepco, Inc.

Data subject to change without notice.

©2011, KEPSCO, INC.
P/N 243-1308-r2



KEPCO, INC. • 131-38 SANFORD AVENUE • FLUSHING, NY. 11355 U.S.A. • TEL (718) 461-7000 • FAX (718) 767-1102
email: hq@kepcopower.com • World Wide Web: <http://www.kepcopower.com>



INSTRUCTION MANUAL CORRECTION

**KEPCO MODELS:
BOP 100W, BOP 200W, BOP 400W**

LOAD REACTANCE, PARAGRAPH 1-10D, add the following:

There are two means of eliminating oscillation in the current loop operating with moderate inductive loads and moderate voltage and current:

1. Add capacitance in parallel with the output (inductive load). The value of capacitor can be from 0.1 uF to 1.0 uF depending on the value of the load inductance.
2. Add a series-connected resistor capacitor network in parallel with the output (inductive load). The value of resistor should be in the range of 100 to 500 Ohms and the value of capacitor should be 0.1 uF to 0.5 uF, depending on the load inductance value.

Both options are recommended when the BOP is used with very low frequency output into inductive loads.

NOTE: BOP 200W and 400W units may be converted to ML units in order to eliminate oscillation when dealing with a large range of inductive load values. This upgrade must be accomplished at the Kepco factory in Flushing New York and includes component changes and re-calibration of the unit. Please contact Kepco Sales for price and delivery schedule regarding this upgrade.

When driving heavy inductive loads with high currents, it is possible for the BOP and the load to be damaged by an A-C input power loss which prevents the load's stored energy from being dissipated inside the BOP. To avoid possible damage observe the following:

- Use UPS to supply the BOP.
- Set BOP output current and/or voltage to zero and turn off the BOP after the output current actually reaches a zero value.
- Use properly rated (voltage and current) bipolar transorbs or a properly rated bipolar crowbar element connected directly at the output of the BOP. An alternative is an A-C Normally Closed Contactor connected directly at the output of the BOP. These options may also be combined.

AFTER PAR. 3-3 B) LOAD CONNECTION (I) and PAR. 3-3 C) LOAD CONNECTION (II) add the following:

Load connections to the BOP power supply are achieved via the OUTPUT and COMMON terminals located on either the front or the rear panel, **but not both**. Sense connections must be made from the same location (front or rear panel) as the output and common connections.

AFTER PAR. 3-3 D) A-C GROUND add the following:

The GROUND terminal is connected to CHASSIS of the unit and to the local EARTH-GROUND potential through the A-C power line cord. It can be used a) as a monitoring reference point, b) as a grounding point for the output of the unit, and c) for doubling the a-c power cord EARTH-GROUND connection if necessary by providing a separate connection to the local EARTH-GROUND point.

CAUTION: NEVER CONNECT THE BOP OUTPUT TERMINAL (OR THE LOAD TERMINAL TIED TO THE OUTPUT TERMINAL) TO EARTH-GROUND. OTHERWISE, IF THE CONTROLLING DEVICE IS GROUNDED, THE BOP CAN BE DAMAGED BY THE OUTPUT LIMIT CURRENT FLOWING INSIDE THE BOP ALONG THE PROGRAMMING SIGNAL RETURN PATH.

CAUTION: DO NOT CONNECT BOTH THE LOAD AND THE PROGRAMMING DEVICE RETURN (COMMON) TO EARTH-GROUND POTENTIAL AND DO NOT USE THE PROGRAMMING RETURN TERMINAL AS A TAP POINT FOR THE LOAD RETURN. OTHERWISE, IF THE COMMON POWER CONNECTION BETWEEN THE BOP AND THE LOAD IS LOST, THE BOP CAN BE DAMAGED BY OUTPUT CURRENT FLOWING INSIDE THE BOP ALONG THE PROGRAMMING SIGNAL RETURN PATH.

CAUTION: DO NOT USE THE PROGRAMMING RETURN TERMINAL AS A TAP POINT FOR THE LOAD RETURN BECAUSE THE BOP CAN BE DAMAGED BY OUTPUT CURRENT FLOWING INSIDE THE BOP ALONG THE PROGRAMMING SIGNAL RETURN PATH.

AFTER PAR. 3-3 E) D-C (SIGNAL) GROUND add the following:

The GROUNDING NETWORK terminal is tied to GROUND (CHASSIS) terminal through a series capacitor-resistor network. Connecting the GROUNDING NETWORK terminal to the COMMON terminal reduces common noise current flowing through the load and, if a BIT card is installed, it ensures that the dynamic swing of the output does not affect the digital section.

AFTER PAR. 3-3 J) EXTERNAL LEADS add the following:

K) EXTERNAL VOLTAGE MONITOR. Use signal E_O Monitor Output at pin 20 of the PC12 programming connector (see Figure 4-5) for external voltage monitoring. Caution should be exercised in handling this signal: use a series 5K resistor in combination with a high impedance monitoring device, or an external high impedance buffer between the BOP and the monitoring device. This signal is buffered by OPAMP IC23 (see Figure 6-4) which functions as a repeater for the signal coming from the RN3 matched pair divider connected at the output. There is no overvoltage protection. This stage is protected against short-circuit by the intrinsic protection of the OPAMP generating this signal. This signal is used by the BIT card if it is installed.

L) EXTERNAL CURRENT MONITOR. Use signal I_O Sensing Output at pin 10 of the PC12 programming connector (see Figure 4-5) for external current monitoring. This signal is not buffered. Use a series 5K resistor in combination with a high impedance monitoring device, or an external high impedance buffer between the BOP and the monitoring device. **CAUTION: An accidental short-circuit at this terminal while the unit is in Current mode or Current limit mode will damage the BOP power stage.** There is no overvoltage protection. This stage is protected against short-circuit by the intrinsic protection of the OPAMP generating this signal. This signal is used by the BIT card if it is installed.

DIGITAL CONTROL OF BOP POWER SUPPLIES, PARAGRAPH 3-46 add the following:

The SN and SNR Programmers and the BIT 488 cards described in this manual are older methods of controlling BOP power supplies via digital means. Although these products still function as described, the recommended method of digital control is now the use of Kepco's BIT 4886 16-bit plug-in card with resolution of $1/2^{16}$. This plug-in card provides talk-listen support for the IEEE 488.2 bus using SCPI commands. The BIT 4886 card allows a BOP to communicate as a stand-alone instrument, directly on the GPIB. The BIT 4886 card also allows the BOP to be programmed over the RS232C bus using either SCPI or CILL commands via either an RS232-C terminal, or from a PC using a terminal emulation program with a baud rate of 9600, no parity, eight data bits and one stop bit. The downloadable BIT 4886 driver supports digital calibration (no manual pots) and multiple control and read-back ranges, For more information refer to: www.kepcopower.com/bit.htm.

Declaration of Conformity

Application of Council directives: **73/23/EEC (LVD)**
93/68/EEC (CE mark)

Standard to which Conformity is declared:

EN61010-1:2001 (Safety requirements for electrical equipment for measurement, control and laboratory use - Part 1)

Manufacturer's Name and Address: **KEPCO INC.**
131-38 SANFORD AVENUE
FLUSHING, N.Y. 11355 USA

Importer's Name and Address:

REPRESENTATIVE COPY

Type of Equipment: **Component Power Supply**

Model No.: *[PRODUCT MODEL NUMBER]*

Year of Manufacture:

I, the undersigned, declare that the product specified above, when used in conjunction with the conditions of conformance set forth in the product instruction manual, complies with the requirements of the Low Voltage Directive 73/23/EEC, which forms the basis for application of the CE Mark to this product.

Place: **KEPCO Inc.**
131-38 Sanford Ave.
Flushing, N.Y.11352 USA

Saul Kupferberg
(Full Name)

Date: _____

VP OF SALES
(position)

Conditions of Conformance

When this product is used in applications governed by the requirements of the EEC, the following restrictions and conditions apply:

1. For European applications, requiring compliance to the Low Voltage Directive, 73/23/EEC, this power supply is considered a component product, designed for "built in" applications. Because it is incomplete in construction, the end product enclosure must provide for compliance to any remaining electrical safety requirements and act as a fire enclosure. (EN61010-1:2001, Cl. 6, Cl. 7, Cl.8, and Cl. 9)
2. This power supply is designed for stationary installation, with mains power applied via a detachable power supply cord or via direct wiring to the source power terminal block.
3. This power supply is considered a Class 1 (earthed) product, and as such depends upon proper connection to protective earth for safety from electric shock. (EN61010-1 Cl. 6.5.4)
4. This power supply is intended for use as part of equipment meant for test, measurement and laboratory use, and is designed to operate from single phase, three wire power systems. This equipment must be installed within a suitably wired equipment rack, utilizing a three wire (grounded) mains connection. See wiring section of this manual for complete electrical wiring instructions. (EN61010-1 Cl. 6.5.4 and Cl.6.10.1)
5. This power supply has secondary output circuits that are considered hazardous, and which exceed 240 VA at a potential of 2V or more.
6. The output wiring terminals of this power supply has not been evaluated for field wiring and, therefore, must be properly configured by the end product manufacturer prior to use.
7. This power supply employs a supplementary circuit protector in the form of a circuit breaker mounted on the front panel. This circuit breaker protects the power supply itself from damage in the event of a fault condition. For complete circuit protection of the end product, as well as the building wiring, it is required that a primary circuit protection device be fitted to the branch circuit wiring. (EN61010-1:2001, Cl. 9.5)
8. Hazardous voltages are present within this power supply during normal operation. All operator adjustments to the product are made via externally accessible switches, controls and signal lines as specified within the product operating instructions. There are no user or operator serviceable parts within the product enclosure. Refer all servicing to qualified and trained Kepco service technicians.

SAFETY INSTRUCTIONS

1. Installation, Operation and Service Precautions

This product is designed for use in accordance with EN 61010-1 and UL 3101 for Installation Category 2, Pollution Degree 2. Hazardous voltages are present within this product during normal operation. The product should never be operated with the cover removed unless equivalent protection of the operator from accidental contact with hazardous internal voltages is provided:



There are no operator serviceable parts or adjustments within the product enclosure. Refer all servicing to trained service technician.



Source power must be removed from the product prior to performing any servicing.



This product is factory-wired for the nominal a-c mains voltage indicated on the rating nameplate located adjacent to the source power connection on the product's rear panel. To reconfigure the product input for other nominal mains voltages as listed herein, the product must be modified by a trained service technician.

2. Grounding

This product is a Class 1 device which utilizes protective earthing to ensure operator safety.



The PROTECTIVE EARTHING CONDUCTOR TERMINAL must be properly connected prior to application of source power to the product (see instructions on installation herein) in order to ensure safety from electric shock.



PROTECTIVE EARTHING CONDUCTOR TERMINAL - This symbol indicates the point on the product to which the protective earthing conductor must be attached.



EARTH (GROUND) TERMINAL - This symbol is used to indicate a point which is connected to the PROTECTIVE EARTHING TERMINAL. The component installer/ assembler must ensure that this point is connected to the PROTECTIVE EARTHING TERMINAL.

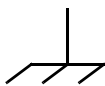

CHASSIS TERMINAL - This symbol indicates frame (chassis) connection, which is supplied as a point of convenience for performance purposes (see instructions on grounding herein). This is not to be confused with the protective earthing point, and may not be used in place of it.

3. Electric Shock Hazards

This product outputs hazardous voltage and energy levels as a function of normal operation. Operators must be trained in its use and exercise caution as well as common sense during use to prevent accidental shock.



This symbol appears adjacent to any external terminals at which hazardous voltage levels as high as 500V d-c may exist in the course of normal or single fault conditions.



This symbol appears adjacent to any external terminals at which hazardous voltage levels in excess of 500V d-c may exist in the course of normal or single fault conditions.

TABLE OF CONTENTS

PARAGRAPH	PAGE
SECTION I—INTRODUCTION	
1-1 Scope of Manual.....	1-1
1-3 General Information.....	1-1
1-8 Electrical Specifications, General.....	1-1
1-9 Electrical Specifications, Performance.....	1-2
1-10 Miscellaneous Features.....	1-4
1-11 Mechanical Specifications.....	1-7/1-8
1-12 Accessories, Supplied.....	1-7/1-8
1-13 Accessories, Not Supplied.....	1-7/1-8
SECTION II—INSTALLATION	
2-1 Unpacking and Inspection.....	2-1
2-3 Terminations.....	2-1
2-4 A-C Input Requirements.....	2-4
2-6 Cooling.....	2-4
2-8 Preliminary Check-out.....	2-4
2-10 Installation of 3/4 Rack BOP Models.....	2-5
2-12 Installation of Full-Rack BOP Models.....	2-5
SECTION III—OPERATION	
3-1 Introduction.....	3-1
3-5 BOP Operation with Local (Front Panel) Output Control.....	3-7
3-10 BOP Operation with Remote Control of the Voltage Control Channel.....	3-7
3-17 Remote Output Voltage Control by means of a d-c Signal Voltage.....	3-9
3-22 The BOP as an Amplifier.....	3-10
3-28 BOP Operation with Remote Control of the Current Control Channel.....	3-13
3-31 Remote Control of the BOP Current Limit.....	3-17
3-34 Remote Control of the BOP Voltage Limit.....	3-19
3-36 SERIES and PARALLEL Connection of BOP Power Supplies.....	3-21
3-46 Digital Control of BOP Power Supplies.....	3-25
3-83 The Circuit Breaker Control Circuit.....	3-30
3-85 The Indicator and Flag Logic Circuits.....	3-30
3-87 Internal Adjustments and Calibrations.....	3-33

LIST OF ILLUSTRATIONS

FIGURE	PAGE
1-1A Kepco Bipolar Operational Power Supply (¾ Rack BOP).....	v
1-1B Kepco Bipolar Operational Power Supply (Full-Rack BOP).....	vi
1-2 BOP Output Characteristic.....	1-4
1-3 BOP Output Wave Form.....	1-4
1-4 Mechanical Outline Drawing, BOP.....	1-9/1-10
2-1 Location of Internal Calibration Controls.....	2-1
2-2 BOP Terminations and Controls.....	2-2
2-3 A-C Source Voltage Selection.....	2-4
2-4 Slide Installation of the Full-Rack Size BOP.....	2-6
SIMPLIFIED APPLICATION AND TEST SET-UP DIAGRAMS	
3-1A BOP Voltage Control Channel.....	3-2
3-1B BOP Current Control Channel.....	3-2
3-1C BOP (±) Voltage Limit Circuits.....	3-3
3-1D BOP (±) Current Limit Circuits.....	3-3
LOAD CONNECTIONS TO THE BOP	
3-2A Load Connection at the Rear, Without Error Sensing.....	3-5
3-2B Load Connection at the Front, Without Error Sensing.....	3-5
3-3A Load Connection at the Rear, With Error Sensing.....	3-6
3-3B Load Connection at the Front, With Error Sensing.....	3-6
APPLICATIONS, VOLTAGE CONTROL CHANNEL	
3-4 Remote Potentiometer Control of the BOP Output Voltage.....	3-8
3-5 Remote d-c Output Voltage Control by Means of a Two-Terminal Resistance.....	3-8
3-6 Digital Control of the BOP d-c Output Voltage.....	3-9
3-7 BOP d-c Output Voltage Control with a High Impedance (±) 1 Volt Signal Source.....	3-10
3-8 Graphs of Possible Input/Output Wave Shapes.....	3-11
3-9 Basic Programming Circuit for Use of the BOP as a Bipolar Amplifier (Voltage Mode).....	3-12
3-10 Programming Circuit for driving the BOP Output Voltage with a (±) 1 Volt Signal.....	3-12
3-11 Programming Circuit for driving the BOP Output Voltage with a High Impedance Source, using the Non-Inverting Input of PRE-AMP "A".....	3-13
APPLICATIONS, CURRENT CONTROL CHANNEL	
3-12 Local (Front Panel) Control of the BOP Output Current with the (Built-in) Current Control.....	3-13
3-13 Remote Potentiometer Control of the BOP Output Current.....	3-14
3-14 Remote Output Current Control by means of a Two-Terminal Resistance.....	3-14
3-15 Digital Control of the BOP Output Current.....	3-15
3-16 BOP Output Current Control with a High Impedance (±) 1 Volt Signal Source.....	3-15
3-17 Basic Programming Circuit for use of the BOP as a Bipolar, Current Stabilized Amplifier.....	3-16
3-18 Programming Circuit for driving the BOP Output Current with a Bipolar (±) 1 Volt Signal Source.....	3-16
3-19 Programming Circuit for driving the BOP Output Current with a High Impedance Source.....	3-17

APPLICATIONS, CURRENT LIMIT CIRCUITS

3-20	Local (Front Panel) Control of the BOP Current Limit Circuit	3-17
3-21	Symmetrical Remote Control of the BOP Current Limit Circuit.....	3-18
3-22	Independent Remote Control of the BOP (+) I_o and (-) I_o Limit	3-18

APPLICATIONS, VOLTAGE LIMIT CIRCUITS

3-23	Local (Front Panel) Control of the BOP Voltage Limit Circuit.....	3-19
3-24	Symmetrical Remote Control of the BOP Voltage Limit Circuit	3-19
3-25	Independent Remote Control of the (+) E_o and (-) E_o Limit	3-20

SERIES AND PARALLEL CONNECTIONS OF BOP SUPPLIES

3-26	Master/Slave Series Connection of two BOP Power Supplies.....	3-21
3-27	Master/Slave Parallel Connection of two BOP Power Supplies	3-23

SIMPLIFIED DIAGRAMS, OF BOP CIRCUIT SECTIONS

3-28	Circuit Breaker Control Circuit.....	3-31
3-29	Indicator Light and Flag Logic Circuit.....	3-32
3-30	Opto-Coupler Linearization	3-33
3-31	Cover Removal and PC Board Disassembly, BOP	3-34
3-32	Component Location, Control Ass'y. (A1)	3-35
3-33	Component Location, Driver Ass'y. (A3), All Except BOP 200-1M, BOP200-1D.....	3-36
3-34	Component Location, Driver Ass'y. (A3), BOP 200-1M, BOP200-1D Only.....	3-36
3-35	Simplified Schematic Diagram, BOP Series.....	3-37

LIST OF TABLES

1-1	Output Range and Impedance.....	1-2
1-2	Output Effects, Offsets and Reference Specifications	1-2
1-3	Dynamic Specifications, BOP Series	1-3
2-1	Internal Calibration Controls and their Functions.....	2-1
2-2	BOP Terminations and Controls	2-3

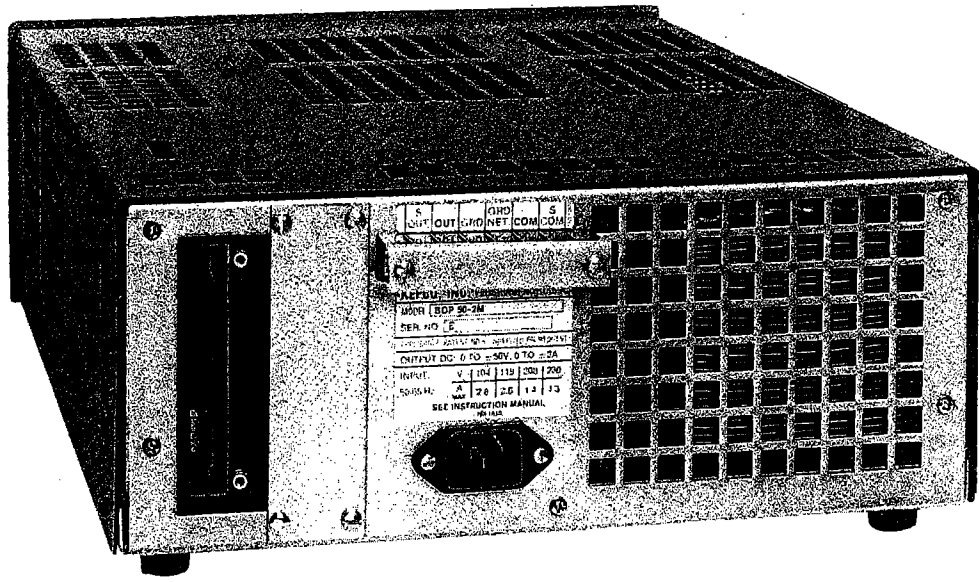
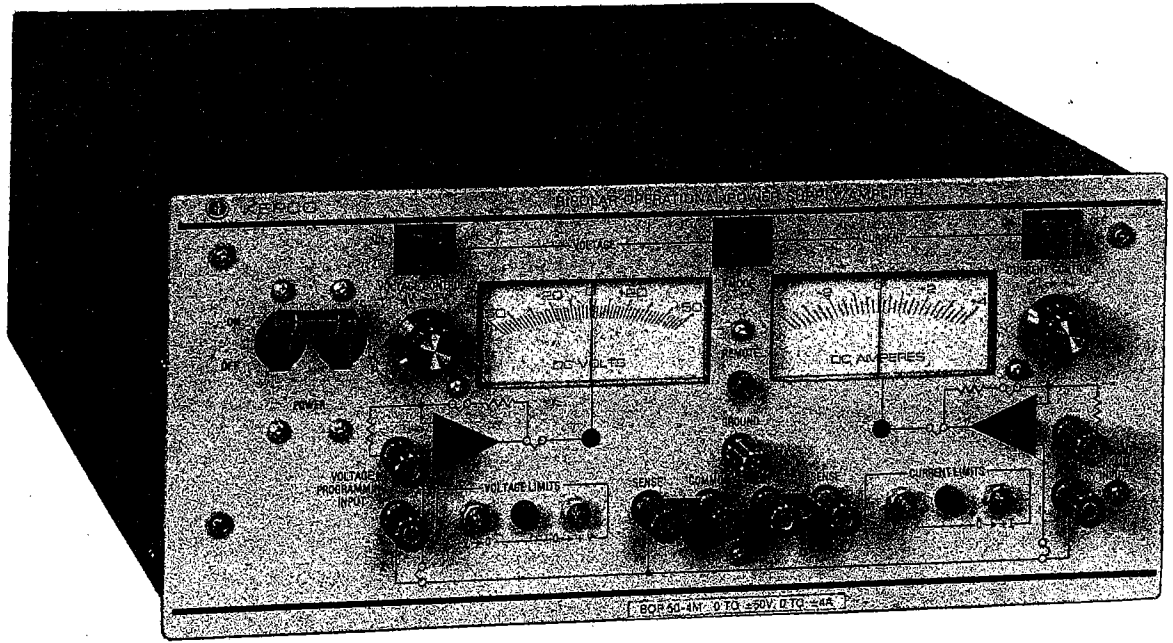

FIG. 1-1A KEPCO BIPOLAR OPERATIONAL POWER SUPPLY (¼ RACK BOP)

SECTION I — INTRODUCTION

1-1 SCOPE OF MANUAL

1-2 This manual contains instructions for the installation and operation of the BOP series of Bipolar, operational power supplies, manufactured by Kepco Inc., Flushing, New York, U.S.A.

1-3 GENERAL DESCRIPTION

1-4 The Kepco series BOP Bipolar Power Supplies are fully dissipative, linear stabilizers for laboratory and systems applications. The BOP is an all solid-state design, featuring IC operational amplifiers in the control circuit section and silicon power transistors mounted on special fan-cooled heat sinks in the complementary power stage.

1-5 The BOP has two bipolar control channels (voltage or current mode), selectable and individually controllable either from their front panel controls, or by remote signals. Each of the principal control channels is protected by bipolar limit circuits. In these limit circuits the positive and negative current or voltage limit points can be manually set or remotely programmed simultaneously or individually. Automatic crossover between each principal control channel and its associated limit channel is provided.

1-6 All control and limit channels are connected to the complementary output stage via an "EXCLUSIVE OR" gate, so that only one channel is in control of the BOP output at any one time. The BOP output can be programmed over its full output range by a ± 10 volt signal applied to either one of the inputs to the voltage or the current channel. The limit control channels can be remotely controlled by a 0 to + 10 volt signal applied to their respective inputs. Two uncommitted preamplifiers, with both, inverting and non-inverting inputs available at the rear programming connector, can scale any programming source to the required input levels. Zero adjustments for both amplifiers are provided.

1-7 The BOP is a fast programmable power supply with considerable bandwidth and thereby sensitive to reactive loads. The dynamic specifications, given in Table 1-3, are valid for resistive loads only.

1-8 ELECTRICAL SPECIFICATIONS, GENERAL

A) INPUT SOURCE REQUIREMENTS: 95 to 113V a-c or 105 to 125V a-c or 190 to 226V a-c or 210 to 250V a-c, 50 to 65 Hz, selectable (refer to Section II, FIG. 2-3). The primary circuit is protected by a circuit breaker, effective at all input voltages. Input current and power are listed in the table below.

B) OPERATING TEMPERATURE RANGE: 0°C to +55°C.

C) STORAGE TEMPERATURE RANGE: - 40°C to + 85°C.

D) COOLING: By built-in, sealed bearing fans, exhausting to the rear of the BOP.

E) ISOLATION FROM GROUND: The BOP circuitry, its output and programming terminals have no d-c connection to the chassis. The COMMON terminal of the BOP can be operated up to 500 volts (d-c or peak) off a-c ground. The common mode current (leakage from output to ground) is less than 50 μ A (rms) or 5 mA (p-p) at 115V a-c power input, 60 Hz.

MODEL	OUTPUT POWER	MAX. INPUT CURRENT	MAX. INPUT POWER	PACKAGE
BOP 20-5M	100W	2.9A	270W	3/4 Rack
BOP 50-2M	100W	2.9A	270W	3/4 Rack
BOP 100-1M	100W	2.9A	270W	3/4 Rack
BOP 20-10M	200W	5.5A	540W	3/4 Rack
BOP 36-6M	200W	5.1A	490W	3/4 Rack
BOP 50-4M	200W	4.8A	450W	3/4 Rack
BOP 72-3M	200W	5.1A	470W	3/4 Rack
BOP 100-2M	200W	4.8A	450W	3/4 Rack
BOP 200-1M	200W	5.5A	450W	Full Rack
BOP 20-20M	400W	11.2A	1115W	Full Rack
BOP 36-12M	400W	10.7A	1050W	Full Rack
BOP 50-8M	400W	9.6A	1000W	Full Rack
BOP 72-6M	400W	10.9A	1085W	Full Rack
BOP 100-4M	400W	9.2A	885W	Full Rack

Approximate maximum input current and power at 125V a-c, 60Hz.

1-9 ELECTRICAL SPECIFICATIONS, PERFORMANCE

A) OUTPUT RANGES: See Table 1-1

MODEL	d-c OUTPUT RANGE		CLOSED LOOP GAIN		OUTPUT IMPEDANCE			
	E_o max.	I_o max.	VOLTAGE CHANNEL G_V (V/V)	CURRENT CHANNEL G_I (A/V)	VOLTAGE MODE		CURRENT MODE	
					SERIES R	SERIES L	SHUNT R	SHUNT C
100 WATT								
BOP 20-5M	± 20V	± 5A	2.0	0.5	80μΩ	20μH	40kΩ	0.05μF
BOP 50-2M	± 50V	± 2A	5.0	0.2	0.5mΩ	100μH	50kΩ	0.05μF
BOP 100-1M	±100V	± 1A	10.0	0.1	2.0mΩ	200μH	100kΩ	0.05μF
200 WATT								
BOP 20-10M	± 20V	±10A	2.0	1.0	40μΩ	40μH	20kΩ	0.05μF
BOP 36-6M	± 36V	± 6A	3.6	0.6	120μΩ	20μH	36kΩ	0.03μF
BOP 50-4M	± 50V	± 4A	5.0	0.4	0.25mΩ	50μH	50kΩ	0.02μF
BOP 72-3M	± 72V	± 3A	7.2	0.3	0.48mΩ	60μH	72kΩ	0.05μF
BOP 100-2M	±100V	± 2A	10.0	0.2	1.0mΩ	200μH	100kΩ	0.03μF
BOP 200-1M ⁽¹⁾	±200V	± 1A	20.0	0.1	4.0mΩ	1.2mH	200kΩ	0.03μF
400 WATT								
BOP 20-20M	± 20V	±20A	2.0	2.0	20μΩ	10μH	20kΩ	0.5μF
BOP 36-12M	± 36V	±12A	3.6	1.2	60μΩ	50μH	36kΩ	0.4μF
BOP 50-8M	± 50V	± 8A	5.0	0.8	125μΩ	100μH	50kΩ	0.15μF
BOP 72-6M	± 72V	± 6A	7.2	0.6	240μΩ	200μH	72kΩ	0.1μF
BOP 100-4M	±100V	± 4A	10.0	0.4	500μΩ	200μH	100kΩ	0.1μF

(1) Same size as 400W models

TABLE 1-1 OUTPUT RANGE AND OUTPUT IMPEDANCE

B) OUTPUT EFFECTS: See Table 1-2.

STATIC SPECIFICATIONS

INFLUENCE QUANTITY	OUTPUT EFFECTS ⁽¹⁾				PREAMPLIFIER ⁽⁵⁾ OFFSETS		REFERENCE ± 10V
	VOLTAGE MODE TYPICAL	MAXIMUM	CURRENT MODE TYPICAL	MAXIMUM	ΔE_{Io}	ΔI_o	
SOURCE VOLTAGE (min-max):	< 0.0005%	0.001%	< 0.002%	0.005%	< 5μV	< 1nA	< 0.0005%
LOAD (No Load-full load):	< 0.001%	0.002%	< 0.5mA	1mA	—	—	< 0.0005%
TIME (8-hour drift):	< 0.005%	0.01%	< 0.01%	0.02%	< 20μV	< 1nA	< 0.005%
TEMPERATURE, per °C:	< 0.005%	0.01%	< 0.01%	0.02%	< 20μV	< 1nA	< 0.005%
RIPPLE and NOISE: ⁽²⁾	rms	< 1mV	3mV ⁽⁴⁾	< 0.01%	0.03%	—	—
	p-p ⁽³⁾	< 10mV	30mV ⁽⁴⁾	< 0.1%	0.3%	—	—

(1) Output effects, expressed as a percentage, are referred to the maximum rated output voltage or current.

(2) Measured with the common terminal grounded so that the common mode current does not flow through the load.

(3) Peak-to-peak ripple is measured over a 20 Hz to 10 MHz bandwidth.

(4) For BOP 200-1M the maximum ripple and noise is 5mV rms and 50mV p-p.

(5) To permit calculation of the effect of non-standard control current (less than the normal 1 mA) or non-standard gain ratios.

TABLE 1-2 OUTPUT EFFECTS, OFFSETS AND REFERENCE SPECIFICATIONS.

- C) The BOP **output effects**, in response to the tabulated variations in the INFLUENCE QUANTITIES, are given in Table 1-2 for the built-in input and feedback resistor values of the voltage and current channel preamplifiers. The tabulated OFFSET VALUES (see Table 1-2) may be used to calculate the BOP **output effects** if the BOP voltage or current channel is remotely programmed and different values for the feedback resistors (R_f) and the input resistors (R_i) are used. In this case, the tabulated preamplifiers offsets and the values of the feedback and input resistors are combined in an "Error Equation", which represents the "Worst Case" output effect for the application at hand:

$$\text{VOLTAGE MODE: } \Delta E_o = G_v [\pm \Delta E_{io} (1 + R_f/R_i) \pm \Delta I_{io} R_f \pm \Delta E_{ref}]$$

$$\text{CURRENT MODE: } \Delta I_o = G_i [\pm \Delta E_{io} (1 + R_f/R_i) \pm \Delta I_{io} R_f \pm \Delta E_{ref}]$$

Where: ΔI_o = Total Output Current Change.
 G_v = Closed Loop Gain, Voltage Mode, (see Table 1-1).
 G_i = Closed Loop Gain, Current Mode, (see Table 1-1).
 ΔE_o = Total Output Voltage Change.
 ΔE_{ref} = Change in the Voltage Reference.
 ΔE_{io} = Change in Offset Voltage.
 ΔI_{io} = Change in Offset Current.
 R_f = External Feedback Resistor.
 R_i = External Input Resistor.

NOTE: Variations in the value of the feedback and input resistors are considered secondary effects in the Error Equation. See Section IV of this manual for the derivation of the Error Equation.

- E) PEAK POWER: $\pm (E_o \text{ max}) (I_o \text{ max})$, Where: $E_o \text{ max.}$ = Maximum rated BOP output voltage.
 $I_o \text{ max.}$ = Maximum rated BOP output current.
- F) DYNAMICS: The typical dynamic responses of the BOP output are tabulated in Table 1-3 in both the time domain (Output response to a step program) and in the frequency domain (bandwidth) for large and small signals.

MODEL	BANDWIDTH (D-C to f _{3dB}) kHz (minimum) Mode		RISE & FALL TIME 10% -90% µsec (maximum) Mode		LARGE SIGNAL FREQUENCY (min) RESPONSE, kHz Mode		SLEWING RATE (minimum) Mode		RECOVERY STEP LOAD µsec (maximum) Mode	
	V	I	V	I	V	I	V	I	V	I
100 WATT										
BOP 20-5M	18	12	20	30	17	13	5V/µsec	0.15A/µsec	25	10
BOP 50-2M	18	12	20	30	17	13	5V/µsec	0.15A/µsec	25	10
BOP 100-1M	18	11	17	22	18	11	11V/µsec	70mA/µsec	40	25
200 WATT										
BOP 20-10M	18	6	20	60	17	7	2V/µsec	0.4A/µsec	80	20
BOP 36-6M	16	13	20	27	15	14	3V/µsec	0.5A/µsec	50	35
BOP 50-4M	23	14	14	25	15	11	4.5V/µsec	0.25A/µsec	40	30
BOP 72-3M	20	15	18	26	17	12	10V/µsec	0.15A/µsec	30	30
BOP 100-2M	22	15	18	26	17	12	10V/µsec	0.15A/µsec	30	30
BOP 200-1M	4.0	2.5	110	150	4.0	2.5	5V/µsec	15mA/µsec	150	120
400 WATT										
BOP 20-20M	9.5	10	35	35	8	10	1V/µsec	1.25A/µsec	100	75
BOP 36-12M	20	10	16	30	19	10	4V/µsec	0.75A/µsec	50	30
BOP 50-8M	24	10	14	35	24	11	7.5V/µsec	0.5A/µsec	40	30
BOP 72-6M	19	9.5	18	40	20	11	9V/µsec	0.4A/µsec	50	20
BOP 100-4M	18	14	22	30	16	10	10V/µsec	0.25A/µsec	40	30

TABLE 1-3 DYNAMIC SPECIFICATIONS, BOP 100W, BOP 200W AND BOP 400W MODELS

1-10 MISCELLANEOUS FEATURES

- A) **OUTPUT RANGE:** The BOP can be locally (front panel) adjusted, or remotely programmed, from (-)100% to (+)100% of its specified d-c voltage and current range. The Class A bipolar output stage permits operation as either a SOURCE or a SINK. (See FIG. 1-2).

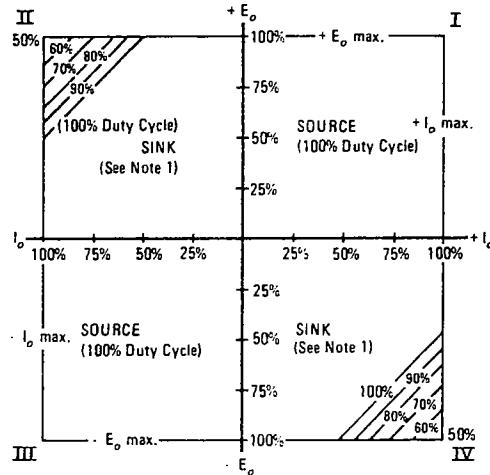

FIG. 1-2 BOP OUTPUT CHARACTERISTIC

NOTE: The values for $\pm E_o \text{ max}$ and $\pm I_o \text{ max}$ are listed in the model table.

NOTE: The duty cycle of the BOP operating in the SINK mode must be derated as shown on the graph.

Note: The BOP is operating as a SOURCE if the direction of its output voltage is *the same* as the direction of its output current. The BOP is operating as a SINK if the direction of its output voltage is *opposite* that of its output current. An illustrative case is shown in FIG. 1-3, where the BOP is programmed to deliver a sine wave output and where the load produces a phase shift between the output voltage and current.

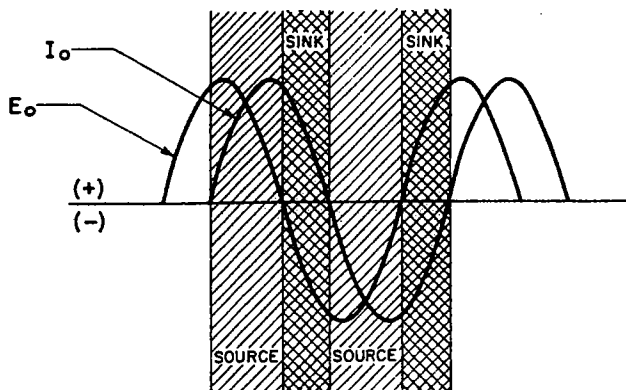

FIG. 1-3 BOP OUTPUT WAVE FORM WITH PHASE SHIFT

B) REAR PROGRAMMING CONNECTORS (See Table 2-2, items 22 and 23)

- 1) The external rear programming connector, called "PC-12" throughout this manual, is an unwired 50-pin edge connector, providing access to all circuit features. The BOP is delivered with one(1) PC-12 connector, with jumpers wired for local (front-panel) operation. Spare connectors may be purchased from Kepco under the model number "PC-12" for the unwired connector and "PC-15" for a connector wired for local operation. The pin-out for the rear programming connector or (PC-12) is shown below.

PIN	FUNCTION	DESCRIPTION	
1	CURRENT LIMIT BIAS	Section III, paragraph 3-31	
3	VOLTAGE LIMIT BIAS	Section III, paragraph 3-34	
11		Section III, paragraph 3-11 for example	
9			
5			
7			
15		Section III, paragraph 3-28 for example	
13			
2			
4			
6	+ E _o LIMIT INPUT	Section III, paragraph 3-34	
8	+ I _o LIMIT INPUT	Section III, paragraph 3-31	
32	- E _o LIMIT INPUT	Section III, paragraph 3-34	
34	- I _o LIMIT INPUT	Section III, paragraph 3-31	
10	CURRENT SENSING AMP. OUTPUT	Analog output voltage (0 to ±10V, 1mA max.) proportional to the prevailing BOP output current for remote metering or monitoring.	
20	VOLTAGE MONITOR AMP. OUTPUT	Analog output voltage (0 to ±10V, 1 mA max.) proportional to the prevailing BOP output voltage.	
21,43, 44,45,46	NOT USED		
12,14	RESERVED (NOT TO BE USED)		
16,18	CURRENT MODE COMPENSATING TERMINALS	Section I, paragraph 1-10D	
26,36	TURN-OFF SIGNAL OUTPUT	Section III, paragraph 3-83	
24	CKT BREAKER CONTROL	Section III, paragraph 3-83	
41	NON-ISOLATED TURN-OFF SIGNAL INPUT	Section III, paragraph 3-83	
47/48, 49/50	OPTICALLY ISOLATED TURN-OFF SIGNAL INPUT	Section III, paragraph 3-83	
17	VOLTAGE COMPARISON AMP. INPUT	An analog input voltage of 0 to ±10V will produce 0 to ± full output voltage or current.	
19	CURRENT COMPARISON AMP. INPUT		
22	- 10V REFERENCE VOLTAGE, 4mA MAX.	Section III, paragraph 3-11 for example	
28	+ 10V REFERENCE VOLTAGE, 4mA, MAX.		
23 25 27 29 31 33	} SENSING COMMON	-----	
30		VOLTAGE MODE COMMAND	Section I, paragraph 1-10L
35		LOCAL/REMOTE OUTPUT FLAG	Section III, paragraph 3-85 Built in TTL logic supply, 5V @ 40mA max.
37		+ 5V	
38		I _o LIMIT FLAG	Section III, paragraph 3-85
39		E _o LIMIT FLAG	Section III, paragraph 3-85
40	E _o MODE FLAG	Section III, paragraph 3-85	
42	I _o MODE FLAG	Section III, paragraph 3-85	

- 2) **AUXILIARY (OPTIONAL) PROGRAMMING CONNECTOR.**
For standard BOP models, the space for this connector is covered. If the BOP contains accessory cards for digital programming, the cover is removed and access to the interface card is provided. The method of termination depends on the interface model. Refer to Section III, paragraphs 3-46 through 3-82.
- 3) Remote turn-off of the BOP by a contact closure, or by an optically isolated input signal.
- 4) Circuit breaker shut down prevention circuit.
- 5) **REFERENCES:** Two reference/bias sources ($\pm 10V$ at 4 mA MAX.) are provided for control and biasing purposes. These reference sources are available at the rear programming connector (with reference to the "COMMON" terminal). Their specifications are tabulated in Table 1-2.
- C) **OFFSET NULLING:** Controls are provided to zero the initial offsets (E_{i0} , I_{i0}) of the voltage and current control preamplifiers and the **MAIN AMPLIFIERS.**
- D) **LOAD REACTANCE:** To realize the full high speed potential of the BOP, the load characteristics should be mainly resistive. Load capacitance and inductance up to 0.2 μF and 0.5 mHy respectively can be tolerated without performance deterioration. The BOP phase-gain versus frequency characteristic is determined by the corner frequency of the response curve (f_{-3dB} breakpoint), as indicated in the Dynamic Specification Table (Table 1-3), and the Closed Loop Gain (G_V -Voltage Mode, G_I -Current Mode), as shown in Table 1-1
At unity gain crossover frequency, there is a substantial phase margin which assures stability into resistive loads. Additional phase shift is introduced, however, by reactive loads (RC-in voltage mode, RL-in current mode), which will reduce the phase margin at the unity gain crossover frequency and will cause peaking in the BOP's dynamic response.
If the load's corner frequency is below the BOP's, the system will be stable, but the frequency response will be governed by the load. When operating with inductive loads greater than 0.5 mHenry in the Current Mode, a compensating capacitor may be required across the Current Comparison Amplifier. Two terminals have been provided for this purposes at the Rear Programming Connector (PC-12, pins 16,18).
- E) **SERIES OR PARALLEL OPERATION:** See Section III of this manual.
- F) **VOLTAGE CONTROL CHANNEL:** (Refer to Section III - FIG. 3-1A). The **BIPOLAR VOLTAGE AMPLIFIER**, with a fixed gain (See Table 1-1 for gain value) is connected, via the **MODE** switch, to the (unity gain) **VOLTAGE PREAMPLIFIER**. If the **VOLTAGE CONTROL** switch is "on", the BOP output voltage can be locally controlled by means of the (front panel) (\pm) 10 volts bias source, from (-) 100% (through zero) to (+) 100% of the rated value. The **VOLTAGE PREAMPLIFIER** is provided with a **ZERO** control and all its terminals are available at the rear programming connector for remote control of the output voltage. Control methods are described in Section III of this manual.
- G) **MODE SWITCH:** The BOP is equipped with a front panel mounted **MODE SWITCH**, which selects bipolar voltage or bipolar current control. See paragraph 1-10L for remote **MODE** control.
- H) **CURRENT CONTROL CHANNEL** (Refer to Section III-FIG. 3-1B). The **BIPOLAR CURRENT AMPLIFIER**, with a fixed gain (see Table 1-1 for gain value), is connected via the **MODE** switch to the (unity gain) **CURRENT PREAMPLIFIER**. If the **CURRENT CONTROL** switch is "on", the BOP output current can be locally (front panel) controlled (by means of the ± 10 volt bias source) from (-)100% (through zero) to (+)100% of the rated value. The **CURRENT PREAMPLIFIER** is provided with a **ZERO** control and all its terminals are available at the rear programming connector for remote control of the output current. Control methods are described in Section III of this manual.
- J) **BOUNDING:** (Refer to Section III - FIG. 3-1C & D). The BOP has four output voltage/current limiting circuits (-) E_o LIMIT, (+) E_o LIMIT, (-) I_o LIMIT, (+) I_o LIMIT for overvoltage/overcurrent protection in either operating mode. All limiting circuits can be screwdriver adjusted by means of four front panel controls. In addition, all four limits can be remotely controlled by means of 0 to 10 volt d-c control voltages. The four limits may be programmed independently or the (\pm) voltage and (\pm) current limits can be controlled in pairs. The adjustable/programmable limit controls are backed-up by front panel-adjustable limit circuits which define the four boundaries [(\pm) E_o MAX and (\pm) I_o MAX.] of the BOP, and provide protection against accidental overprogramming of the adjustable limits.

1-10 J) (Cont'd)

The four boundary quantities ($\pm E_o$ MAX. and ($\pm I_o$ MAX. as applied to the LIMIT CHANNEL, are actually about 10% greater than the **rated** values E_o MAX. and I_o MAX. for each BOP model. Similarly, the quantities E_o ZERO and I_o ZERO are not really "zero", but approximately 0.2% of the **rated** E_o MAX. and I_o MAX. values for each BOP model. (See graph below).

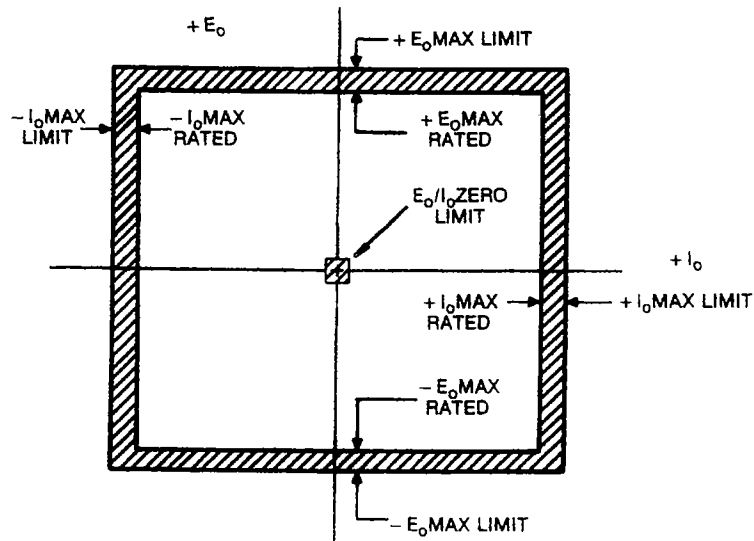

- K) **MODE LIGHTS:** Four (4) front panel (LED type) indicator lamps monitor the prevailing operating mode of the BOP. For each operating condition (VOLTAGE MODE, CURRENT MODE, $\pm E_o$ LIMIT, $\pm I_o$ LIMIT) the corresponding indicator lamp energizes. Simultaneous TTL flags available on the REAR PROGRAMMING CONNECTOR. See paragraph 1-10B.
- L) **REMOTE OPERATING MODE SELECTION.** The operating mode of the BOP, normally selected by means of a manual switch on the front panel, may be remotely selected by a remote switch or TTL logic levels. Proceed as follows:
 - 1) Wire the REMOTE/LOCAL FLAG line on the REAR PROGRAMMING CONNECTOR (PC-12, term. 35) to SENSING COMMON. This will cause the front-panel REMOTE LED to light and the front panel MODE switch will be disabled. ALL OTHER FRONT PANEL CONTROLS WILL STILL BE FUNCTIONAL.
 - 2) The operating mode of the BOP may now be controlled by means of terminal 30 on PC-12. With an open terminal (or logic HIGH), the BOP will operate in the Voltage Mode. Returning terminal 30 to SENSING COMMON (or logic LOW) will change the operating mode to Current Mode.
- M) **STANDARDS:** BOP models are designed and tested in accordance with NEMA Standard for Stabilized Power Supplies, d-c output, Publication No. PY-1-1972.

1-11 **MECHANICAL SPECIFICATIONS**

- A) **DIMENSIONS:** See "Mechanical Outline Drawing". FIG. 1-4.
- B) **FINISH:** See "Mechanical Outline Drawing". FIG. 1-4.
- C) **FRONT PANEL METERS:** Two (2) "zero center" meters, monitoring the \pm d-c output voltage and the \pm d-c output current, are provided; 2½ inches wide, recessed; Accuracy, $\pm 2\%$ full scale.
- D) **SHIPPING WEIGHT:** ¼-RACK BOP MODELS: 51 lbs., 23 Kg, unpacked.
FULL RACK BOP MODELS: 75 lbs., 34 Kg, unpacked.

1-12 **ACCESSORIES, SUPPLIED**

- A) **REAR PROGRAMMING CONNECTOR,** Kepco Model PC-12, 50-terminal printed circuit connector for all rear programming connections and flag-signal outputs, wired for local (front panel) control of the BOP output. This connector may be ordered wired under Kepco Model PC-15 and unwired as the Model PC-12.
- B) **(FULL-RACK BOP MODELS ONLY) MOUNTING FLANGES,** for installation of the BOP into a standard (19 inch) equipment rack. A PAIR INCLUDED WITH EACH BOP.
- C) **(FULL-RACK BOP MODELS ONLY) SIDE COVER PLATES,** for bench top use, designed to finish the two sides of the instrument when the rack mounting-ears are not installed. A PAIR INCLUDED WITH EACH BOP.

1-13 **ACCESSORIES, NOT SUPPLIED**

- A) **REAR PROGRAMMING CONNECTOR,** Kepco Model PC-12, unwired.
- B) **RACK ADAPTER,** Kepco Model RA-24; for ¼-rack BOP models and one Kepco ¼-rack model. Filler panel available to cover the empty slot if ¼-rack model is not installed.
- C) **RACK ADAPTER,** Kepco Model RA-37; for ¾-rack BOP models and one Kepco ¼-rack model. Filler panel available to cover empty slot if ¼-rack model is not installed.

SECTION 2 - INSTALLATION

2.1 UNPACKING AND INSPECTION

This instrument has been thoroughly inspected and tested prior to packing and is ready for operation. After carefully unpacking, inspect for shipping damage before attempting to operate. Perform the preliminary operation check as outlined in Paragraph 2-8. If any indication of damage is found, file an immediate claim with the responsible transport service.

2.2 TERMINATIONS

- A) FRONT PANEL: Refer to FIG. 2-2A and Table 2-2.
- B) REAR: Refer to FIG. 2-2B and Table 2-2.
- C) INTERNAL CALIBRATION CONTROLS: Refer to FIG. 2-1 and Table 2-1.

TABLE 2-1 INTERNAL CALIBRATION CONTROLS.

REFERENCE DESIGNATION	CONTROL NAME	PURPOSE	ADJUSTMENT PROCEDURE
R15A ⁽¹⁾	OPTOCOUPLER LINEARITY	LC301 Optocoupler Linearization	Sect. III, Par. 3-87C
R31, 32	(±)10V CAL.	Reference Voltage Calibration	Sect. III, Par. 3-87A
R41	PREAMP "A" ZERO	Uncommitted Amplifier "A" Zero Adjustment	Sect. III, Par. 3-19
R42	PREAMP "B" ZERO	Uncommitted Amplifier "B" Zero Adjustment	Sect. III, Par. 3-30
R50	AMMETER ZERO	Sensing Amp. Offset Adjustment	Sect. III, Par. 3-87B
R81	E _O COMP AMP ZERO	Voltage Channel Zero Adjustment	Sect. III, Par. 3-16
R83	I _O COMP AMP ZERO	Current Channel Zero Adjustment	Sect. III, Par. 3-30
R316 ⁽²⁾ (R314 on BOP 200-1) ⁽²⁾	I _O CAL.	Full Scale Output Current Calibration	Sect. III, Par. 3-87D

NOTES: ⁽¹⁾ R15A for Model BOP 200-1M only.
⁽²⁾ R316 (R314 on BOP 200-1M) applies only to the following Model Revision Numbers (or higher):

BOP 20-5M: REV. 4	BOP 20-10M: REV. 20	BOP 20-20M: REV. 17	BOP 36-6M: REV. 20
BOP 36-12M: REV. 16	BOP 50-2M: REV. 23	BOP 50-4M: REV. 15	BOP 50-8M: REV. 13
BOP 72-3M: REV. 12	BOP 72-6M: REV. 15	BOP 100-1M: REV. 26	BOP 100-2M: REV. 17
BOP 100-4M: REV. 16	BOP 200-1M: REV. 10		

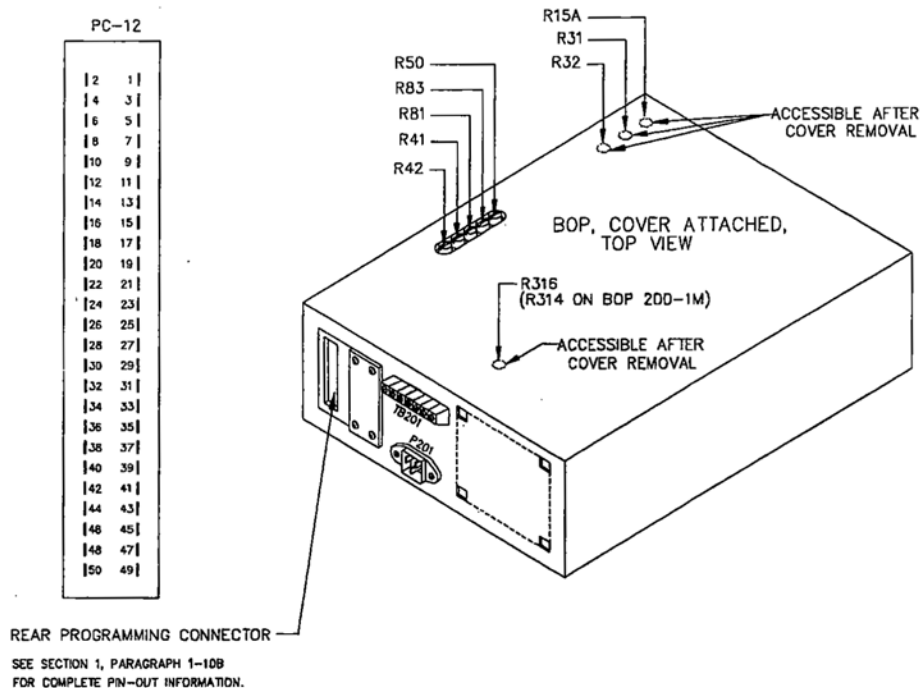
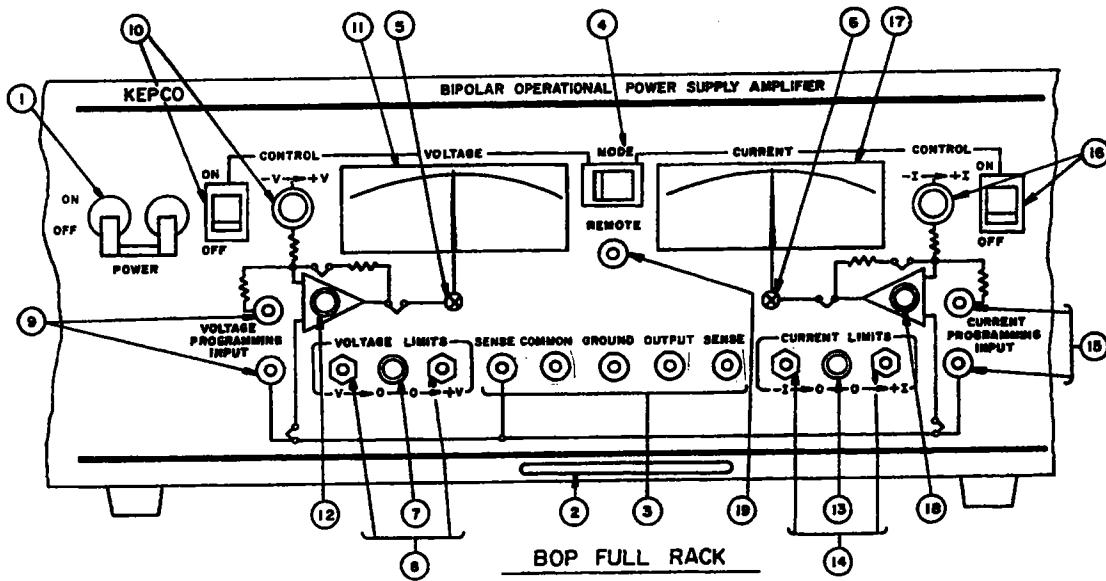
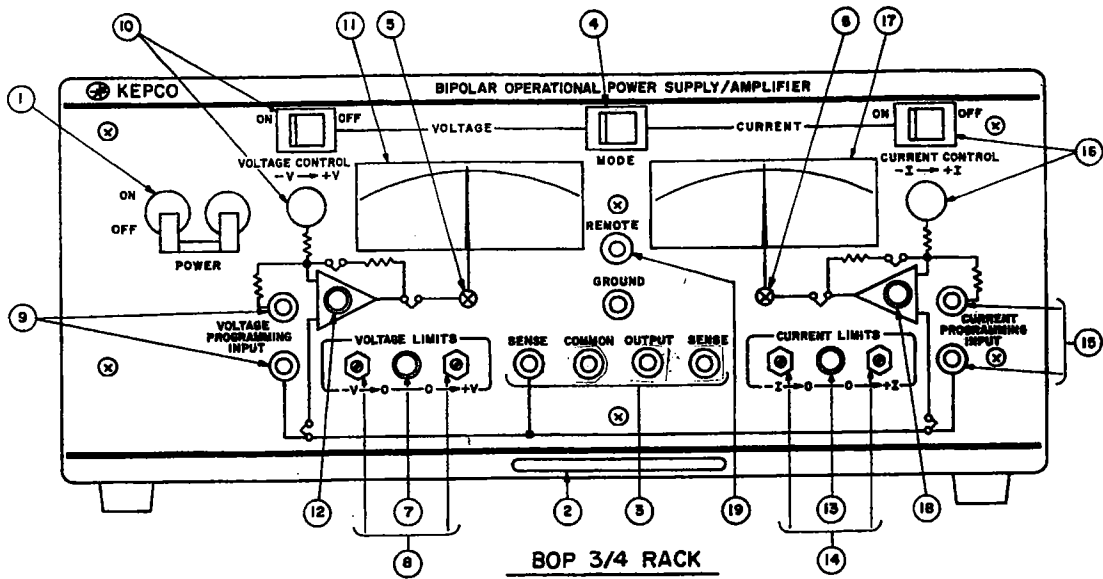
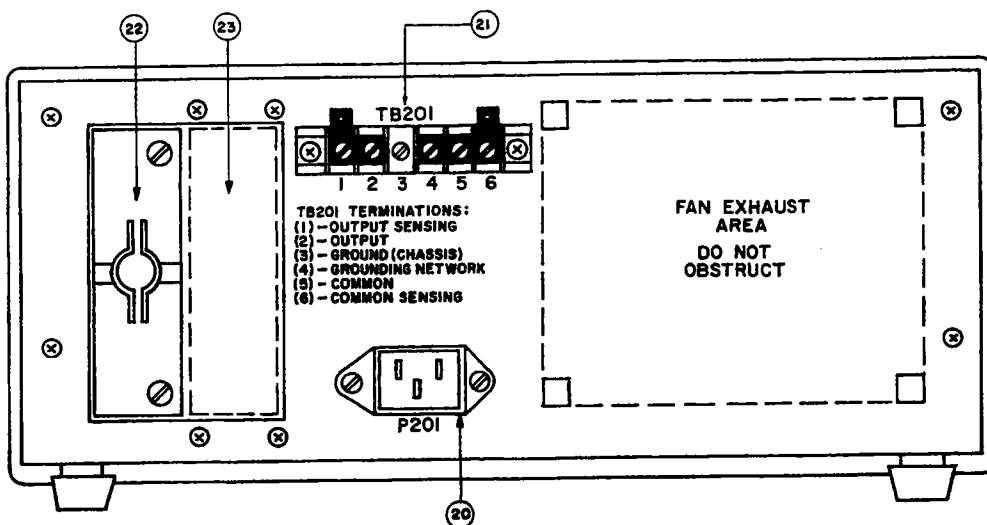

FIGURE 2-1. LOCATION OF INTERNAL CALIBRATION CONTROLS



A) BOP FRONT TERMINATIONS AND CONTROLS



B) BOP REAR TERMINATIONS AND CONTROLS

NO. (FRONT)	NAME OF CONTROL OR TERMINATION	FUNCTION
1	A-C POWER	A-C CIRCUIT BREAKER/POWER SWITCH.
2	N.A.	UNIT NAME PLATE
3	± OUTPUT COMMON, GROUND	OUTPUT AND SENSING TERMINALS WITH CHASSIS GROUND (PARALLEL WITH REAR BARRIER STRIP TERMINALS).
4	MODE	OPERATING MODE SELECTOR SWITCH FOR "VOLTAGE" OR "CURRENT" MODE.
5	N.A.	MECHANICAL VOLTMETER ZERO ADJUSTMENT.
6	N.A.	MECHANICAL CURRENT METER ZERO ADJUSTMENT.
7	VOLTAGE LIMIT	LED LAMP, INDICATING VOLTAGE LIMIT OPERATION.
8	± VOLTAGE LIMIT	CONTROLS FOR MANUAL ADJUSTMENT OF THE (±) VOLTAGE LIMITS.
9	INPUT	PROGRAMMING INPUT TERMINALS FOR VOLTAGE CONTROL CHANNEL.
10	VOLTAGE CONTROL	"ON-OFF" SWITCH AND VOLTAGE CONTROL, FOR MANUAL ADJUST- MENT OF THE BOP D-C OUTPUT VOLTAGE (WITH SWITCH "ON").
11	E _o METER	D-C OUTPUT VOLTMETER (READS ALSO AVERAGE A-C SIGNALS).
12	E _o MODE	LED LAMP, INDICATING VOLTAGE MODE OPERATION.
13	CURRENT LIMIT	LED LAMP, INDICATING CURRENT LIMITING OPERATION.
14	± CURRENT LIMIT	CONTROLS FOR MANUAL ADJUSTMENT OF THE (±) CURRENT LIMITS.
15	INPUT	PROGRAMMING INPUT TERMINALS FOR CURRENT CONTROL CHANNEL.
16	CURRENT CONTROL	"ON-OFF" SWITCH AND CURRENT CONTROL, FOR MANUAL ADJUST- MENT OF THE BOP D-C OUTPUT CURRENT (WITH SWITCH "ON").
17	I _o METER	D-C OUTPUT CURRENT METER (READS ALSO AVERAGE A-C SIGNALS).
18	I _o MODE	LED LAMP, INDICATING CURRENT MODE OPERATION.
19	REMOTE/LOCAL	LED LAMP, INDICATING BOP UNDER REMOTE CONTROL WHEN LIT.
NO. (REAR)		
20	P201	A-C POWER INPUT JACK. ACCEPTS 3-WIRE LINE CORD (SUPPLIED).
21	REAR TERMINALS (TB201)	REAR BARRIER STRIP WITH OUTPUT, SENSING AND GROUND TERMINALS.
22	PC-12	REAR PROGRAMMING CONNECTOR.
23	PC-12 FOR BIT-500 CARD OR SNQ CABLE FOR BIT 488 CARD, OR 20-WIRE FLAT CABLE FOR PCA X-3 IF USED WITH TLD 488-16.	AUXILIARY (OPTIONAL) PROGRAMMING CONNECTOR.

TABLE 2-2 BOP TERMINATIONS AND CONTROLS

NOTE: Numbers correspond to those shown in FIG. 2-2.

2-4 A-C INPUT REQUIREMENTS

2-5 This power supply is normally supplied for operation on a single phase, nominal 115V a-c line. For operation on other a-c source voltages, refer to FIG. 2-3. Check your prevailing nominal source voltage and change the links on the barrier strip of T201 according to the table provided in FIG. 2-3. The circuit breaker (CB101) remains equally effective at all input voltages.

A-C SOURCE	CONNECT LINKS
104V	(3)—(4), (7)—(8)
115V	(4)—(5), (6)—(7)
208V	(2)—(3), (8)—(9)
230V	(5)—(6)

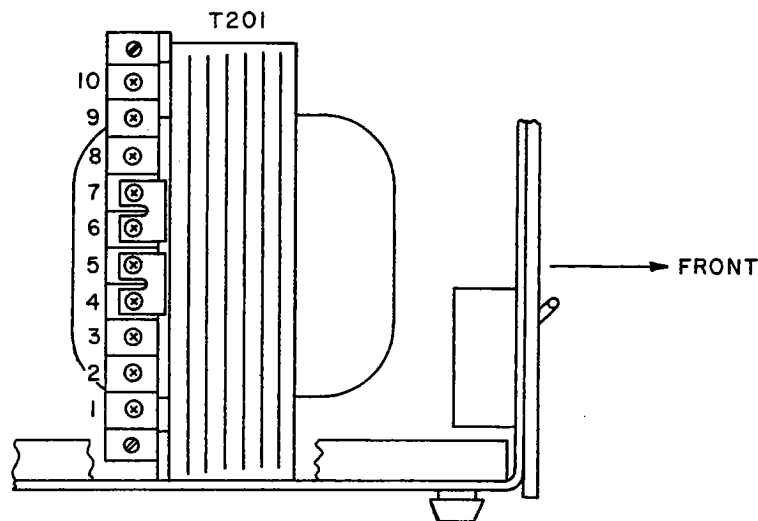

FIG. 2-3 A-C SOURCE VOLTAGE SELECTION.

2-6 COOLING

2-7 The components in the BOP power supply rely on forced air cooling for the maintenance of their operating temperature. SIDE PANEL OPENINGS AND THE TOP OF THE CASE MUST BE KEPT CLEAR FROM ALL OBSTRUCTIONS TO ENSURE AIR CIRCULATION. Periodic cleaning of the interior of the power supply is recommended. **If the BOP is rack-mounted or installed into confined spaces, care must be taken that the ambient temperature (the temperature immediately surrounding the power supply) does not rise above 55°C (≈ 157°F).**

2-8 PRELIMINARY CHECKOUT

NOTE: THE REAR PROGRAMMING CONNECTOR (PC-12) MUST BE ATTACHED TO THE BOP AND MUST BE WIRED AS SHOWN ON THE SIMPLIFIED SCHEMATIC DIAGRAM, FIGURE 3-35, SECTION III.

2-9 A simple operating check after unpacking and before permanent installation, is advisable to ascertain whether the BOP has suffered damage in shipment. Refer to FIG. 2-2 and Table 2-2 FOR THE LOCATION AND DESIGNATION OF THE OPERATING CONTROLS AND TERMINALS. Proceed as follows:

- Connect the BOP to a 115V a-c source, or refer to paragraph 2-4 for conversion to other a-c input voltages if required.
- Note:** The rear sensing links must be attached to the rear barrier strip (TB201) of the BOP as shown in FIG. 2-2 and the rear connector (PC-12) must be attached, wired for LOCAL CONTROL, and secured.
- Set the BOP front panel controls as follows (refer to FIG. 2-2). The controls will be identified here and in the following manual text with the nomenclature used in Table 2-2 and identifying numbers used in FIG. 2-2):
 - MODE switch (4), set to VOLTAGE.
 - VOLTAGE CONTROL (10), set SWITCH to "ON", VOLTAGE CONTROL to its extreme counterclockwise position.
 - A-C CIRCUIT BREAKER/POWER SWITCH (1) to "ON".
- The "E₀ MODE" Lamp (12) will be "on".

- E) Turn the VOLTAGE CONTROL (10) clockwise through its range, while observing the front panel VOLTMETER (11). The BOP output voltage should smoothly respond, from the maximum negative output voltage, over zero, to the maximum positive output voltage of the BOP. Turn A-C CIRCUIT BREAKER/POWER SWITCH (1) "off".
- F) Connect a short circuit between the (\pm) OUTPUT and the COMMON front panel output terminal (3). Set the BOP front panel controls as follows:
 - 1) MODE SWITCH (4), set to "CURRENT".
 - 2) CURRENT CONTROL (16), set SWITCH to "ON", CURRENT CONTROL to its maximum counterclockwise position.
 - 3) A-C CIRCUIT BREAKER/POWER SWITCH (1) to "ON".
- G) The "I_o MODE" Lamp (18) will be "on".
- H) Turn the CURRENT CONTROL (16) clockwise through its range, while observing the front panel AM-METER (17). The BOP output current should smoothly respond, from the maximum negative output current, over zero, to the maximum positive output current of the BOP. Turn A-C CIRCUIT BREAKER/POWER SWITCH (1) "off". Remove the short circuit from the output terminals. THIS CONCLUDES THE PRELIMINARY CHECK-OUT OF THE BOP.

2-10 INSTALLATION FOR $\frac{3}{4}$ RACK BOP MODELS

- 2-11 These BOP models may be bench operated or installed in the RA-24 or RA-37 Rack Adaptors, as listed in Section I, Paragraph 1-13. Installation instructions are provided with the respective rack-adaptor models. For rack-mounting, or mounting onto any flat surface, the (4) bottom aluminum feet of the BOP must be removed. Four (4) plastic mounting inserts are provided on the bottom of the BOP chassis. See Section I, FIG. 1-4, "Mechanical Outline Drawing".

NOTE: FOR ALL INSTALLATIONS INTO CONFINED SPACES, CARE MUST BE TAKEN THAT THE TEMPERATURE IMMEDIATELY SURROUNDING THE UNIT DOES NOT EXCEED THE MAXIMUM SPECIFIED AMBIENT TEMPERATURE (55°C).

2-12 INSTALLATION OF FULL-RACK BOP MODELS (Refer to Section I, Fig. 1-4 and to FIG. 2-4).

- 2-13 Full-rack BOP models are delivered with the FIXED ANGLE BRACKETS and the CHASSIS SIDE SUPPORT BARS installed. For bench operation, both of these components may be removed. The full-rack BOP unit may be installed into standard (19 inch) equipment racks, or onto any other flat surface. For installation, the four (4) bottom aluminum feet must be removed. If chassis slides are not used, the BOP may be installed onto any flat surface by means of the provided plastic mounting inserts on the bottom of the BOP chassis.

2-14 SLIDE INSTALLATION. The CHASSIS SLIDE SUPPORT BARS of the BOP are pre-drilled to accept JONATHAN SERIES 110 QD slides. The following slide models can be accommodated:

MODEL	MOUNTING HOLES USED				
	A	B	C	D	E
110 QD-20-2	X	X	0	X	DR
110 QD-22-2	X	0	X	0	X
110 QD-24-2	X	0	X	0	DR

KEY: X = HOLE USED, 0 = HOLE NOT USED, DR HOLE MUST BE DRILLED INTO CHASSIS PART OF SLIDE, EACH SIDE 0.199 DIA., 16 1/4" FROM "A" HOLE.

2-15 PROCEDURE (Refer to FIG. 2-4):

- 1) REMOVE SCREWS "A" through "E" from left and right CHASSIS SLIDE SUPPORT BARS. (Do not discard).
- 2) Determine the required hole-pattern for the selected slide model from the table.
- 3) Drill the "E" hole into both, left and right chassis section of slide if required.
- 4) Mount the chassis section of the slide to the left and right side of the BOP, as shown in FIG. 2-4. Use the same 10-32 x 1/2" Mounting Screws which you removed in step (1).

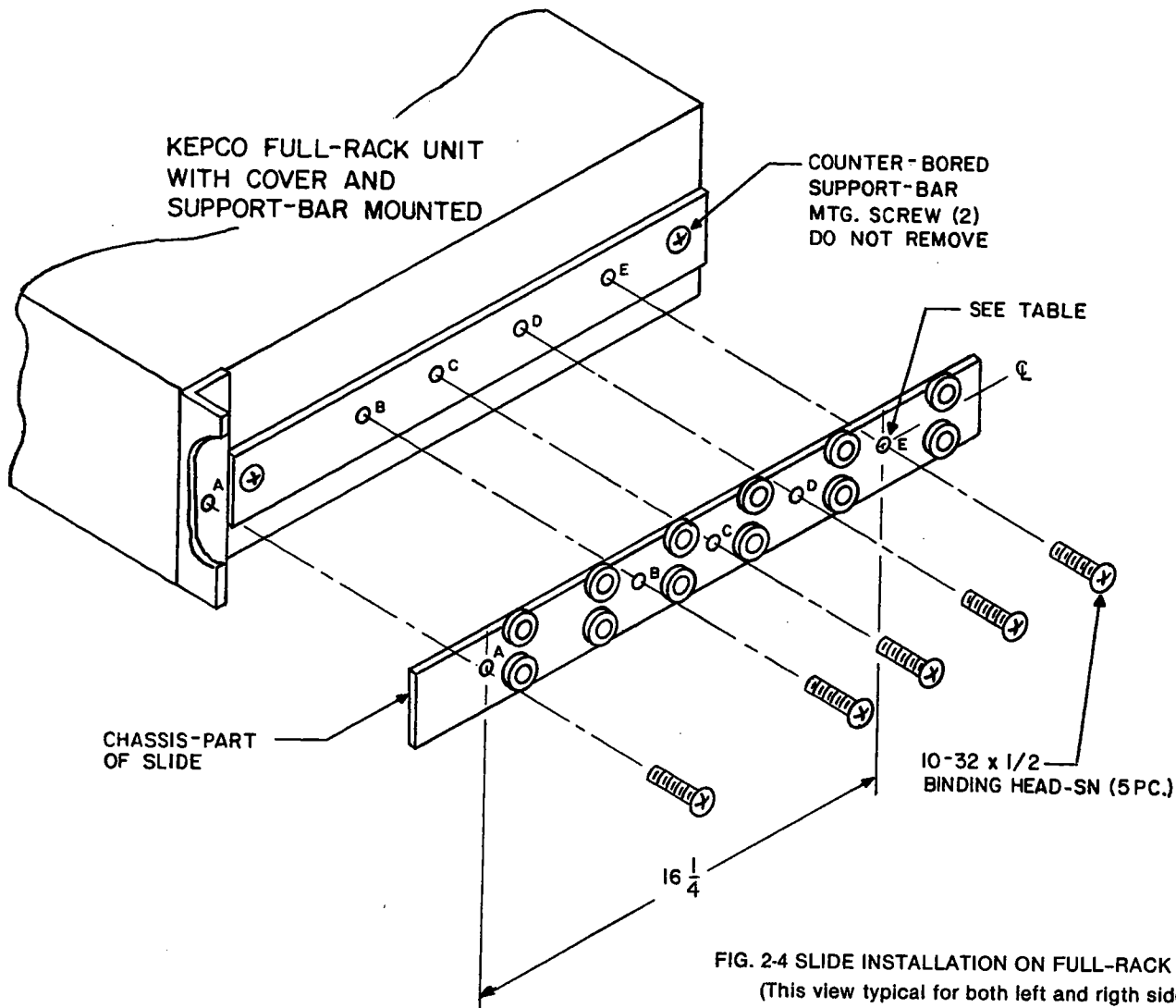

NOTE: If slide installation (as described above) is not desired, other means of supporting the unit in the rear must be provided (additional rear brackets or a solid platform, for example) since the front angle brackets alone are not sufficient to support the full weight of the unit.

SECTION III—OPERATION

3-1 INTRODUCTION

- 3-2 BOP BIPOLAR OPERATIONAL POWER SUPPLIES can be used in a great variety of applications. As a PRECISION VOLTAGE or CURRENT SOURCE, the BOP output can be controlled locally by means of the front panel bipolar VOLTAGE and CURRENT controls or remotely by means of resistance or by voltage signals. Independently adjustable or remotely programmable limit circuits for both output voltage and output current protect a sensitive load from any overvoltage or overcurrent. As a BIPOLAR AMPLIFIER, the BOP output responds for example to such input signals as sine, square or triangular waves. A (\pm) 10 volt input signal will program the BOP output (voltage or current) through its rated output ranges. Built-in preamplifiers, for the voltage, as well as the current channel of the BOP, permit amplification of the control signals to the required amplitude and provide the interface with high as well as low impedance signal sources.
- 3-3 Detailed examples of the more popular applications are described in the following paragraphs. Before actual operation, however, the following general comments on the operation of the BOP should be carefully considered:

SAFETY PRECAUTIONS

- 1) Exercise care in making all connections to and from the BOP terminals. REMOVE A-C POWER FROM THE BOP BEFORE MAKING ANY CONNECTIONS.
- 2) Wires and/or cables, connected from the BOP terminals to external components or programming devices must be properly insulated and securely terminated on both sides to make accidental touch impossible. DO NOT USE BANANA PLUGS WITH EXPOSED SCREWS OR OTHER EXPOSED METAL PARTS AT THE FRONT PANEL OUTPUT TERMINALS!
- 3) The BOP chassis and cover must be safety-grounded to a reliable a-c source ground. A safety-ground may be established by using a grounded a-c power outlet or, if the latter is not available, by means of a separate wire, from the provided "ground" terminal to a reliable a-c source ground point.
- 4) THE COMMON OUTPUT TERMINAL OF THE BOP SHOULD BE SIGNAL GROUNDED. If for any reason, grounding of the output is not possible, additional precautions must be taken to make any access to the isolated output impossible.

- A) DIAGRAMS. Application and test set up diagrams on the following pages show the symbolic and simplified representation of the BOP circuitry in four (4) separate diagrams, as indicated in FIG. 3-1. The diagrams represent the four programmable circuits of the BOP.

FIG. 3-1A: Voltage Control Channel.

FIG. 3-1B: Current Control Channel.

FIG. 3-1C: (\pm) E_o Limit Circuits.

FIG. 3-1D: (\pm) I_o Limit Circuits.

The **complete** simplified diagram is represented in the fold-out page at the end of Section IV. THE FOUR CIRCUITS CAN BE PROGRAMMED SEPARATELY AS DESCRIBED IN THE EXAMPLES IN THIS SECTION, OR THEY CAN BE USED SIMULTANEOUSLY AS THE APPLICATION REQUIRES, WITH THE EXCEPTION OF THE TWO (2) MAIN BIPOLAR VOLTAGE AND CURRENT CHANNELS WHICH ARE MANUALLY SELECTED BY THE FRONT PANEL MODE SWITCH OR REMOTELY BY TTL SIGNALS AND CANNOT BE OPERATED SIMULTANEOUSLY.

The numbered terminals in the diagrams correspond to the connector terminals on the REAR PROGRAMMING CONNECTOR. The terminal designated **C** corresponds to pin numbers 23,25,27,29,31 or 33 on PC-12.

NOTE: BOP's have front and rear output terminals. Only the front terminals are shown on all subsequent simplified diagrams.

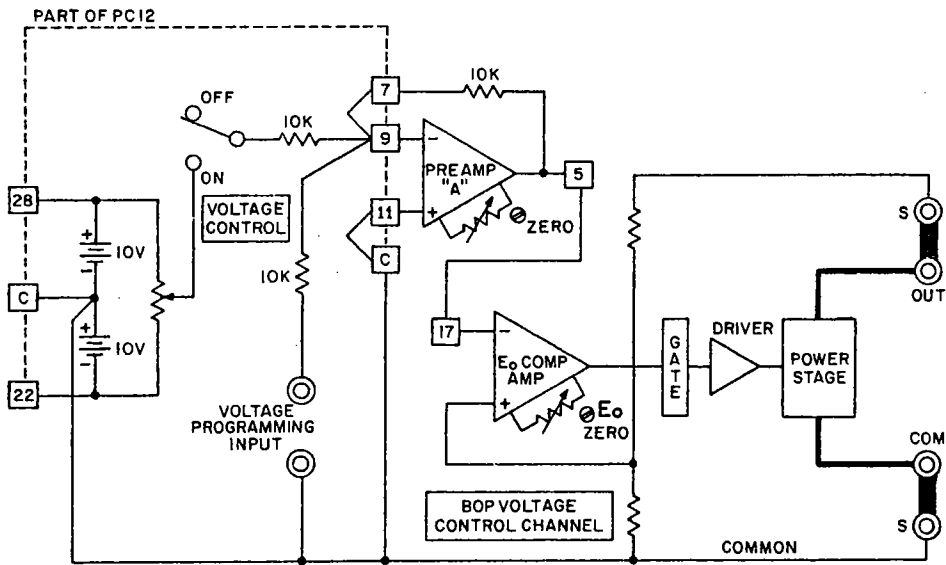

FIG. 3-1A BOP VOLTAGE CONTROL CHANNEL
 NOTE: Mode Switch position: "VOLTAGE".

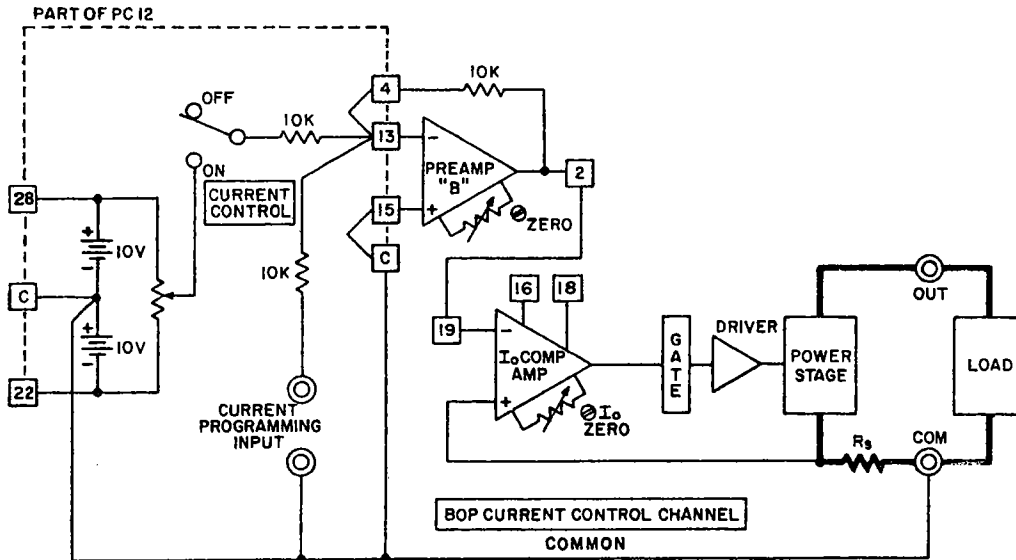

FIG. 3-1B BOP CURRENT CONTROL CHANNEL
 NOTES: 1) Mode Switch position: "CURRENT".
 2) For inductive loads in excess of 0.5 mHy, the BOP output response may be optimized by placing a capacitor across terminals 16 and 18 of the I_o COMP. AMP.

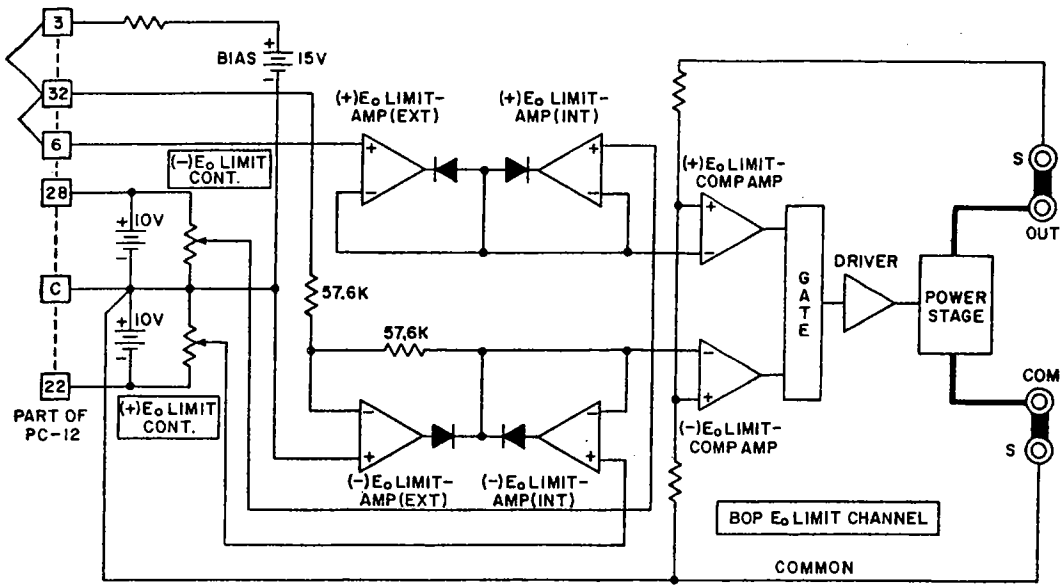

FIG. 3-1C BOP (±) VOLTAGE LIMITING CIRCUIT

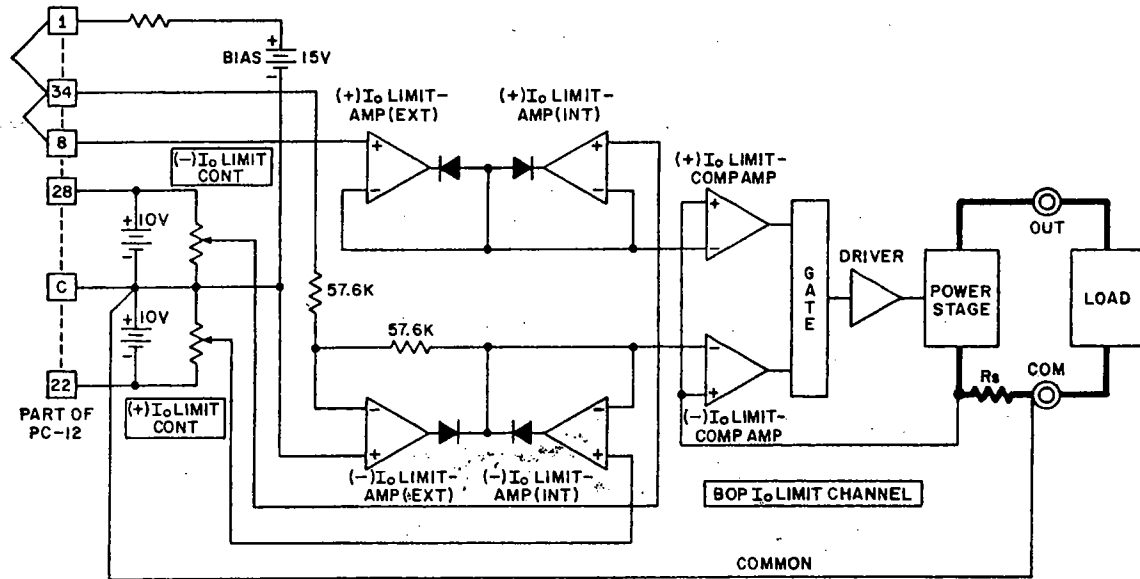

FIG. 3-1D BOP (±) CURRENT LIMITING CIRCUIT

- B) **LOAD CONNECTION (I).** The basic interconnections between the BOP and the load are shown in FIG.'s 3-2A and 3-2B. The load wire size for the 2-wire connection shown should be as large as practicable to keep the series resistance and inductance low. In addition, the load wire pair should be tightly twisted, to reduce possible "pick-up" from stray magnetic fields. The basic 2-wire connection is useful where the voltage drop in the load wires is of minor consequence, as for example, operation into a constant load or in a constant current operating mode.
- C) **LOAD CONNECTION (II).** The recommended load connection for all applications requiring minimum load effect across a remote load is shown in FIG. 3-3A and 3-3B. A twisted, shielded pair of wires (No. 20 AWG minimum) are connected from the BOP sensing terminals to the load. This "remote error sensing" technique will compensate for load wire voltage drops up to 0.5 volts per wire.
NOTE: OBSERVE POLARITIES: THE COMMON SENSING WIRE MUST GO TO THE "COMMON" LOAD WIRE, THE (\pm) OUT SENSING WIRE MUST GO TO THE "(\pm) OUT" LOAD WIRE.
- D) **A-C GROUND.** (Refer to FIG.'s 3-2, 3-3). The metal cases of electronic equipment which is operated from the a-c power line must be kept at ground potential at all times. If the 3-wire line cord with 3-prong safety plug (supplied with this equipment) is used in combination with a properly grounded a-c power outlet, this is taken care of automatically. If an adapter for a non-grounded outlet is used, however, the case must be grounded separately. A separate "GROUND" terminal is provided for this purpose on the front panel as well as on the rear of the BOP. (See Section II, FIG. 2-2).
- E) **D-C (SIGNAL) GROUND.** (Refer to FIG.'s 3-2, 3-3). Specified ripple and noise figures for operational power supplies are valid only with the COMMON side of the output/load circuit returned to a common ground point (refer to Section I, Table 1-2). The COMMON terminal of the BOP output is shown grounded in FIG.'s 3-2A through 3-3B, since it is "common" to both, internal reference source and any external signal source. If the application requires, the COMMON of the BOP may be floated up to 500V d-c off ground. In this case, however, the common mode current (specified in Section I, Paragraph 1-8E, will flow through the impedance of whatever circuit is placed between COMMON and ground and will give rise to a common mode voltage. The signal ground point in the BOP/load circuit must consist of a single point only, to which all input source grounds, shields and load grounds are connected. Multiple signal grounds in the BOP output/load circuit may cause "ground-loop" problems, since noise signals develop across the impedances between the multiple ground points. The exact physical location of the "best" single ground point must be carefully selected for minimum ripple/noise output.
- F) **EXTERNAL PROGRAMMING RESISTORS.** External programming resistors should be high-quality units, with low-temperature coefficients. Resistors should be selected carefully, since in most applications, the limitations for stability and drift are due, not to the BOP, but to the programming resistors. Selection criteria for resistors are:
- 1) TEMPERATURE COEFFICIENT
 - 2) LEAKAGE (IN VALUES ABOVE 100K OHM)
 - 3) HUMIDITY EFFECTS
 - 4) DRIFT WITH TIME
 - 5) SELF-HEATING (POWER DISSIPATION)
 - 6) TOLERANCE.
- G) For variable resistors (potentiometers or rheostats) similar selection criteria apply. In addition, such specifications as listed below should be carefully considered if the application requires:
- 1) END RESISTANCE
 - 2) LINEARITY
 - 3) CAPACITIVE AND INDUCTIVE EFFECTS
- H) **ACTIVE PROGRAMMING SOURCES.** External programming sources (Signal Generators, etc.,) or reference sources should have temperature coefficients and drift specifications comparable to (or better than) the BOP Power Supply. CAUTION: A-C source-operated programming sources must have their output isolated from the case.

- J) **EXTERNAL LEADS.** Shielded (preferably twisted) lead pairs are recommended for all input connections to the BOP control channels. The shield should be connected (single-ended) to the chosen signal ground point. Shielded leads should be held as short as practicable. Output leads must be voltage rated at least for the maximum BOP output voltage.

NOTE: FRONT SENSING LINKS MUST BE REMOVED. REAR SENSING LINKS MUST BE CONNECTED AS SHOWN.

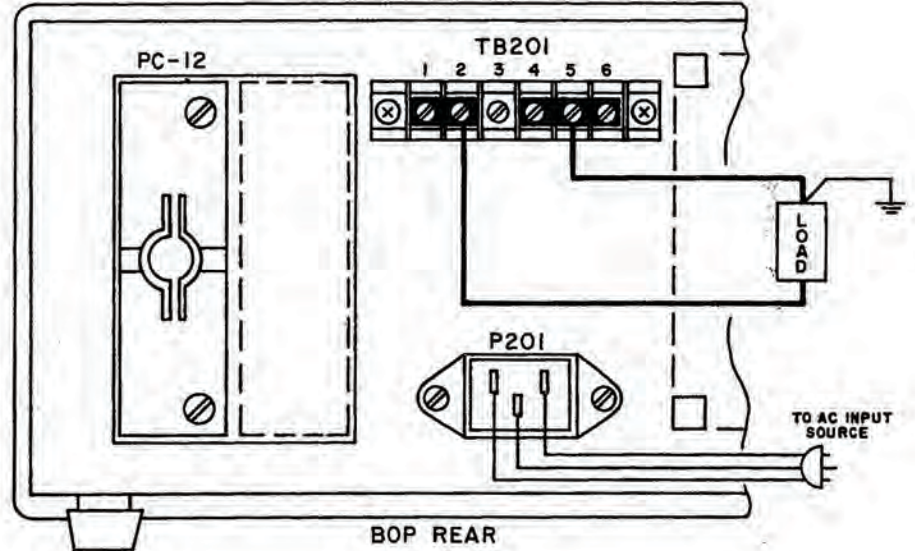

FIG. 3-2A LOAD CONNECTION AT THE REAR, WITHOUT ERROR SENSING.

NOTE: REAR SENSING LINKS MUST BE REMOVED. FRONT SENSING LINKS MUST BE CONNECTED AS SHOWN.

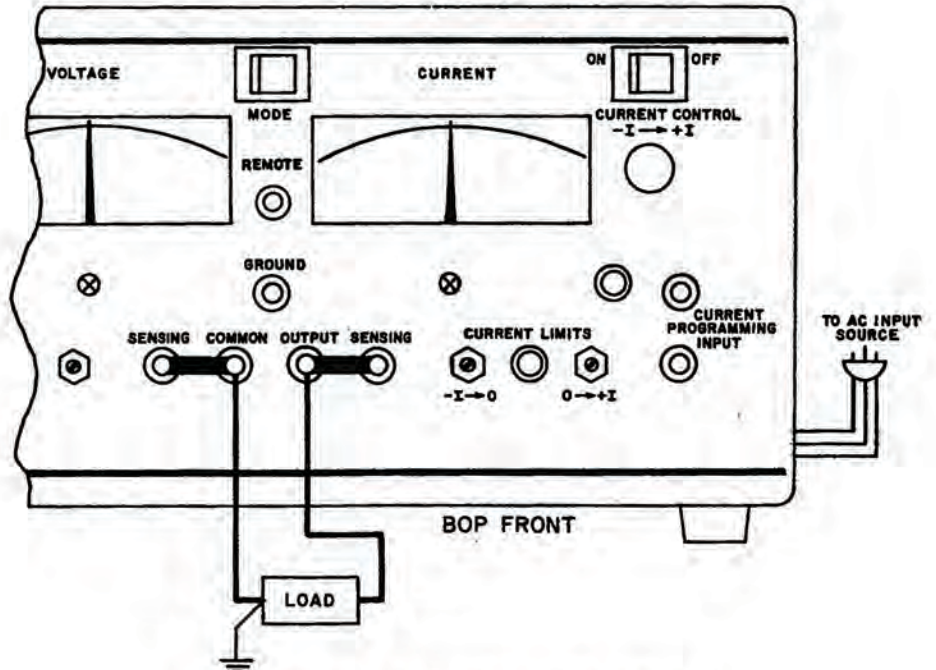

FIG. 3-2B LOAD CONNECTION AT THE FRONT, WITHOUT ERROR SENSING.

NOTE 1) FRONT AND REAR SENSING LINKS MUST BE REMOVED.

NOTE 2) FOR APPLICATIONS REQUIRING VERY LONG CONNECTIONS TO THE LOAD, ADDITIONAL EXTERNAL CAPACITORS (C_x IN FIG.'S 3-3A AND 3-3B) SHOULD BE CONNECTED AS SHOWN, TO COMPENSATE FOR THE LEAD INDUCTANCE OF THE CONNECTING WIRES.

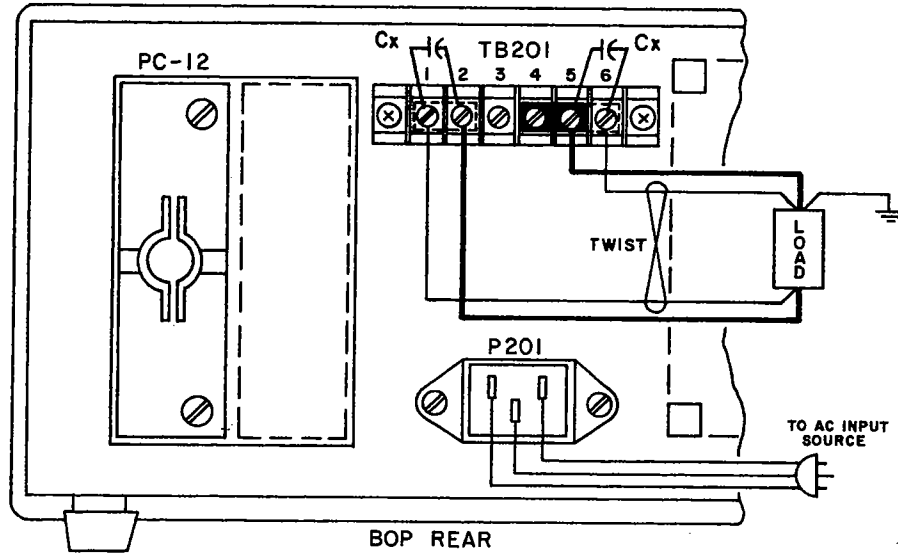

FIG. 3-3A LOAD CONNECTION AT THE REAR, WITH ERROR SENSING.

NOTE 3) FOR APPLICATIONS REQUIRING MANUALLY SWITCHED OR RELAY DRIVEN OUTPUT CONNECTIONS, EXTERNAL RESISTORS MUST BE CONNECTED AS SHOWN. ALL CONNECTIONS SHOULD BE MADE AND BROKEN SIMULTANEOUSLY.

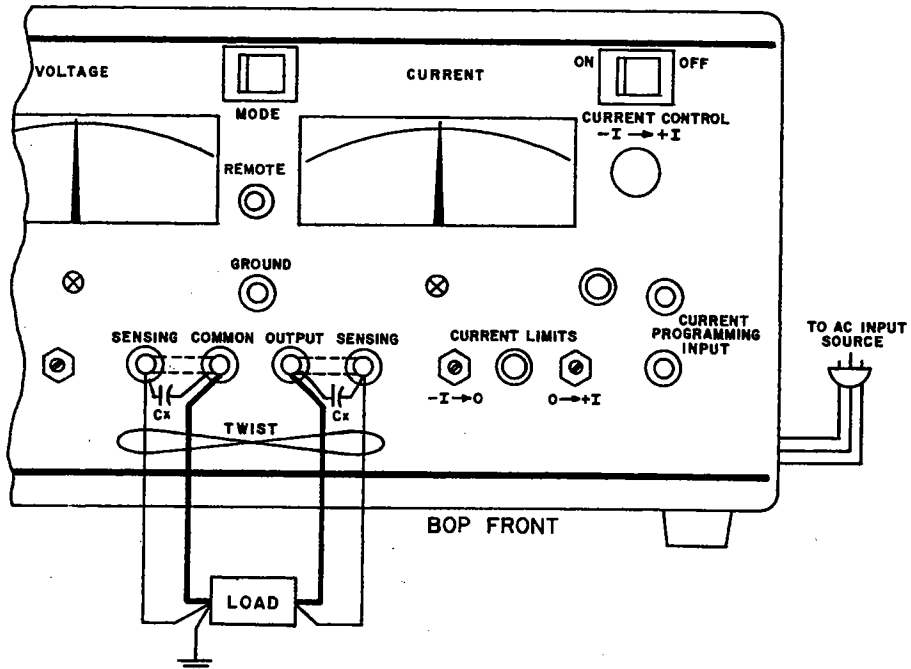
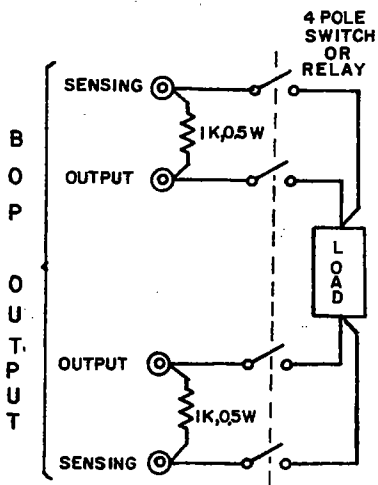

FIG. 3-3B LOAD CONNECTION AT THE FRONT, WITH ERROR SENSING.

3-4 BEFORE USING THE BOP IN ANY APPLICATION, PLEASE REFER TO SECTION II TO GET ACQUAINTED WITH THE OPERATING CONTROLS AND THE A-C POWER REQUIREMENTS. REFER TO THIS SECTION (SECTION III) FOR INFORMATION ON LOAD CONNECTIONS AND GROUNDING.

3-5 BOP OPERATION WITH LOCAL (FRONT PANEL) OUTPUT CONTROL

3-6 VOLTAGE MODE OPERATION WITH CURRENT LIMITING. The BOP may be used as a stabilized (d-c) source of positive or negative voltage with output current limiting (for either polarity) pre-selected for the application at hand.

3-7 PROCEDURE (Refer to Paragraph 3-4)

- 1) Determine the output voltage and current requirements of your load. Set the BOP MODE switch to the VOLTAGE position and the VOLTAGE CONTROL SWITCH to "ON".
- 2) With the BOP A-C CIRCUIT BREAKER/POWER SWITCH "off", connect a short circuit across the output terminals. Turn the BOP "on" again.
- 3) Adjust the I_o LIMIT CONTROLS for both polarities as required, monitoring the OUTPUT CURRENT METER for the correct limiting value. Proceed as follows: Turn VOLTAGE CONTROL fully counterclockwise. Adjust the "(-) I_o LIMIT CONTROL". Turn VOLTAGE CONTROL fully clockwise. Adjust the "(+) I_o LIMIT CONTROL". Turn the VOLTAGE CONTROL to the center of its range. Turn the A-C POWER switch "off" and remove the short circuit from the output and reconnect the load.
- 4) Turn the A-C CIRCUIT BREAKER/POWER SWITCH "on", and adjust the VOLTAGE CONTROL to the desired output voltage.

NOTE: If the output current exceeds the pre-adjusted value at any time the VOLTAGE MODE LIGHT will go out and the $(\pm) I_o$ LIMIT LIGHT will go on. After the cause of the overcurrent is eliminated, the indicator lights will return to their initial status.

3-8 CURRENT MODE OPERATION WITH VOLTAGE LIMITING. The BOP may be used as a stabilized d-c source of positive or negative current, with output voltage limiting (for either polarity), pre-selected for the application at hand.

3-9 PROCEDURE (please refer to Paragraph 3-4)

- 1) Determine the output voltage and current requirement of your load. Set the BOP MODE SWITCH to the CURRENT position and the CURRENT CONTROL switch to "ON".
- 2) With the BOP A-C CIRCUIT BREAKER/POWER SWITCH "off", disconnect the load. Turn the BOP "on" again.
- 3) Adjust the E_o LIMIT CONTROLS for both polarities as required, monitoring the OUTPUT VOLTAGE METER for the voltage limiting value. Proceed as follows: Turn CURRENT CONTROL fully counterclockwise. Adjust the "(-) E_o LIMIT CONTROL". Turn CURRENT CONTROL fully clockwise. Adjust the "(+) E_o LIMIT CONTROL". Turn the CURRENT CONTROL to the center of its range. Turn the A-C POWER switch "off" and reconnect the load.
- 4) Turn the BOP "on" again, and adjust the operating current by means of the CURRENT CONTROL to the value required.

NOTE: If the output voltage exceeds the pre-adjusted value at any time the CURRENT MODE LIGHT will go out and the $(\pm) E_o$ LIMIT LIGHT will go on. After the cause of the overvoltage is eliminated, the indicator lights will return to their initial status.

3-10 BOP OPERATION WITH REMOTE CONTROL OF THE VOLTAGE CONTROL CHANNEL.

3-11 REMOTE D-C OUTPUT VOLTAGE CONTROL BY RESISTANCE. As seen in FIG. 3-4, and as described in a previous paragraph (Paragraph 3-6) the BOP d-c output potential can be controlled within its specified range by means of the VOLTAGE CONTROL, with the VOLTAGE CONTROL SWITCH in the ON position. PREAMP "A" with the built-in feedback and input resistors, has a gain of one and the fixed gain of all BOP models is designed so that a d-c input signal of zero to $(\pm)10$ volt will control the BOP output through its specified range. In the local (front panel) control mode, the d-c control potential is applied via the VOLTAGE CONTROL. In the remote control mode, a similar control circuit, located external to the BOP is substituted for the internal control elements.

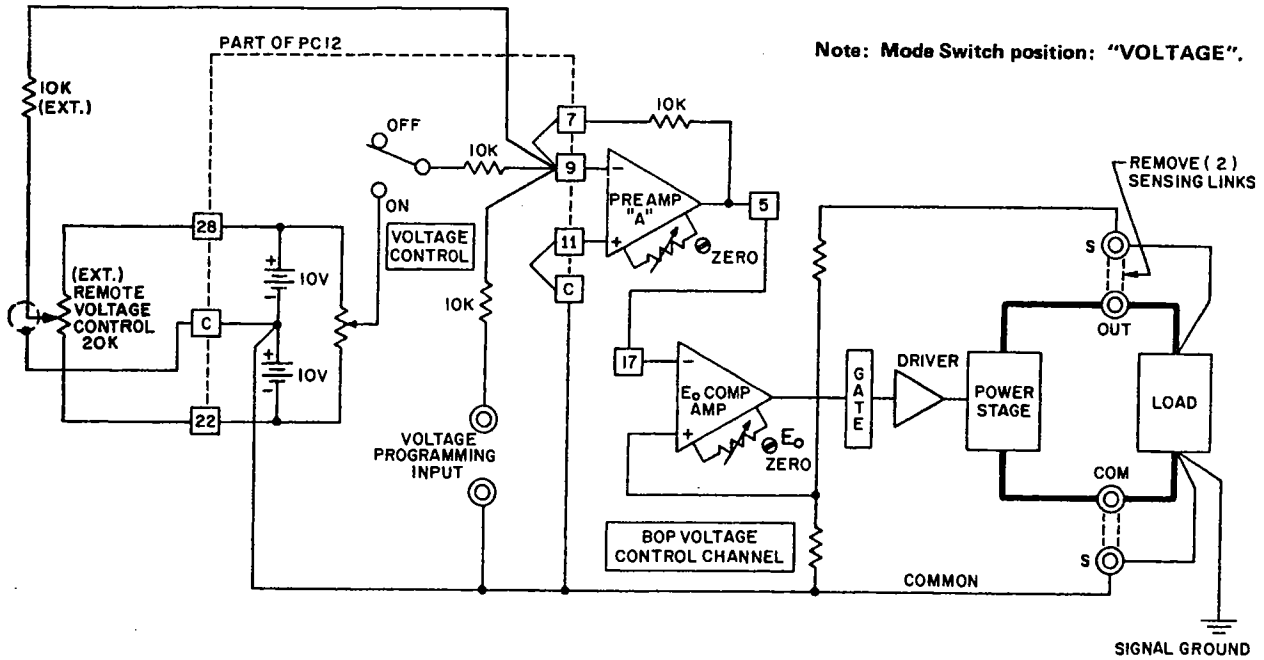

FIG. 3-4 REMOTE POTENTIOMETER CONTROL OF THE BOP D-C OUTPUT VOLTAGE

3-12 As shown in FIG. 3-4, this control method can readily be performed remotely, by setting the VOLTAGE CONTROL SWITCH to the OFF position and connecting an external REMOTE VOLTAGE CONTROL as indicated in FIG. 3-4.

3-13 Two-terminal resistance control of the d-c voltage (for example, by means of a Decade Box) can be exercised as shown in FIG. 3-5.

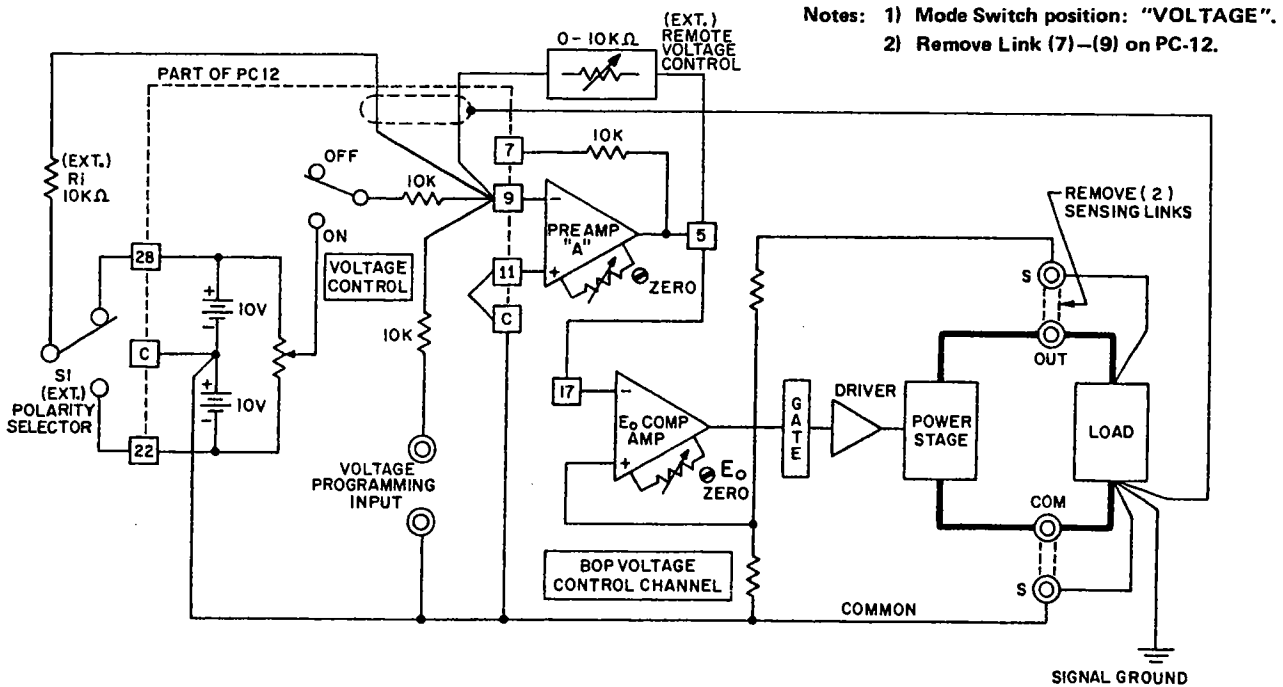

FIG. 3-5 REMOTE D-C OUTPUT VOLTAGE CONTROL BY MEANS OF A TWO-TERMINAL RESISTANCE (DECADE).

3-14 The external switch (S1), connected across the (\pm) reference voltage is used to pre-select either positive or negative output, by setting it to the applicable reference voltage polarity.

3-15 PREAMP "A" functions here as an inverter. Its output can be expressed by the equation:

$$E_{O(\text{PREAMP "A"})} = -E_{\text{ref}} (R_f/R_i). \quad R_f = \text{Decade Resistor.}$$

$$R_i = \text{Ext. Input Resistor}$$

Since $E_{\text{ref}} = (\pm)10$ volts and the gain ratio R_f/R_i is variable from zero to one, its output ($E_{O\text{-PREAMP "A"}}$) will vary linearly from zero to (\pm)10 volts with the change in the decade resistance (R_f). As a consequence, the BOP output voltage will also vary linearly with the change in decade resistance.

3-16 This programming system can be calibrated very accurately by setting the REMOTE VOLTAGE CONTROL (Decade) to zero and adjusting zero output volts at the BOP E_O ZERO control, monitoring at the BOP output with a digital voltmeter. The maximum output voltage is calibrated by making all or part of R_i a rheostat and adjusting it, with the REMOTE VOLTAGE CONTROL at maximum resistance, to the maximum BOP output voltage.

3-17 **REMOTE OUTPUT VOLTAGE CONTROL BY MEANS OF D-C SIGNAL VOLTAGE.** The BOP d-c output voltage can be controlled directly by a (\pm)10V d-c signal, applied to the front panel VOLTAGE PROGRAMMING INPUT terminals. An interesting example of this application is the BOP output voltage control with a Kepco SN Digital Programmer for example. The digital input to the SN programmer can be provided by a computer, or manually by means of a keyboard. The analog output from the SN is from zero to ± 10 volts and constitutes the input program for the BOP.

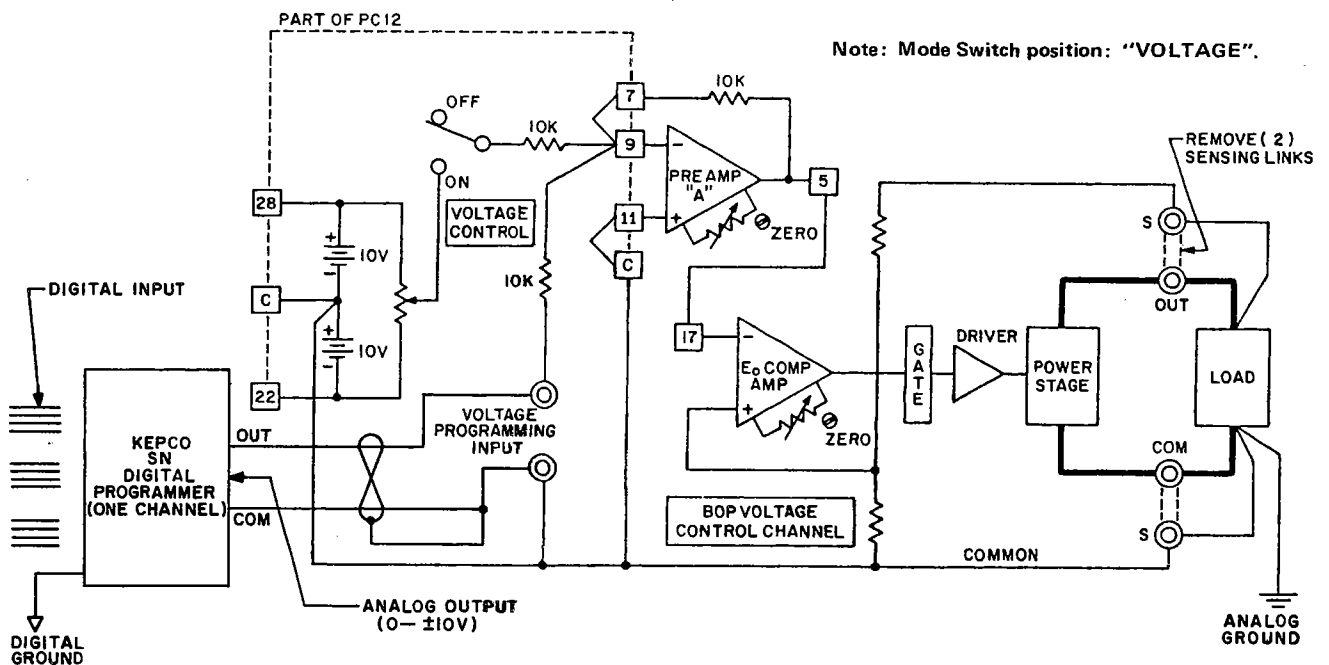

FIG. 3-6 DIGITAL CONTROL OF THE BOP D-C OUTPUT VOLTAGE.

3-18 The connections between the SN Programmer and the BOP are illustrated in FIG. 3-6. This programming system provides a resolution of 12-bits with a linearity of (\pm) $\frac{1}{2}$ LSB (0.0122%). The digital and the power supply grounds are isolated (optical isolation) to 1000 volts. Calibration of the system is performed with the provided controls on the SN Programmer. See paragraphs 3-46 through 3-82 for a description of available Kepco Digital Programming devices suitable for use with the BOP.

3-19 Since all terminals of PREAMP "A" are available at the REAR PROGRAMMING CONNECTOR, d-c output voltage control can be exercised in many other ways. PREAMP "A" can be treated as an uncommitted operational amplifier, with its applicable transfer-functions. Its *initial* offsets can be zeroed with the provided control, while the offset *variations* are specified in Section I of this manual (refer to Table 1-2). The basic principle of d-c output voltage control of the BOP is that a control voltage of (\pm)10 volts at 1 mA at the VOLTAGE PROGRAMMING INPUT (with the built-in feedback/input resistors) will produce the full d-c output voltage swing of the BOP. If the selected control signal does not have the required amplitude or if the required control current cannot be supplied, the PREAMP "A" configuration can be altered to provide the proper interface for the application.

3-20 If, for example, the BOP d-c output is to be controlled by means of a bipolar, 1 volt, high impedance source, it can be connected to the BOP as shown in FIG. 3-7.

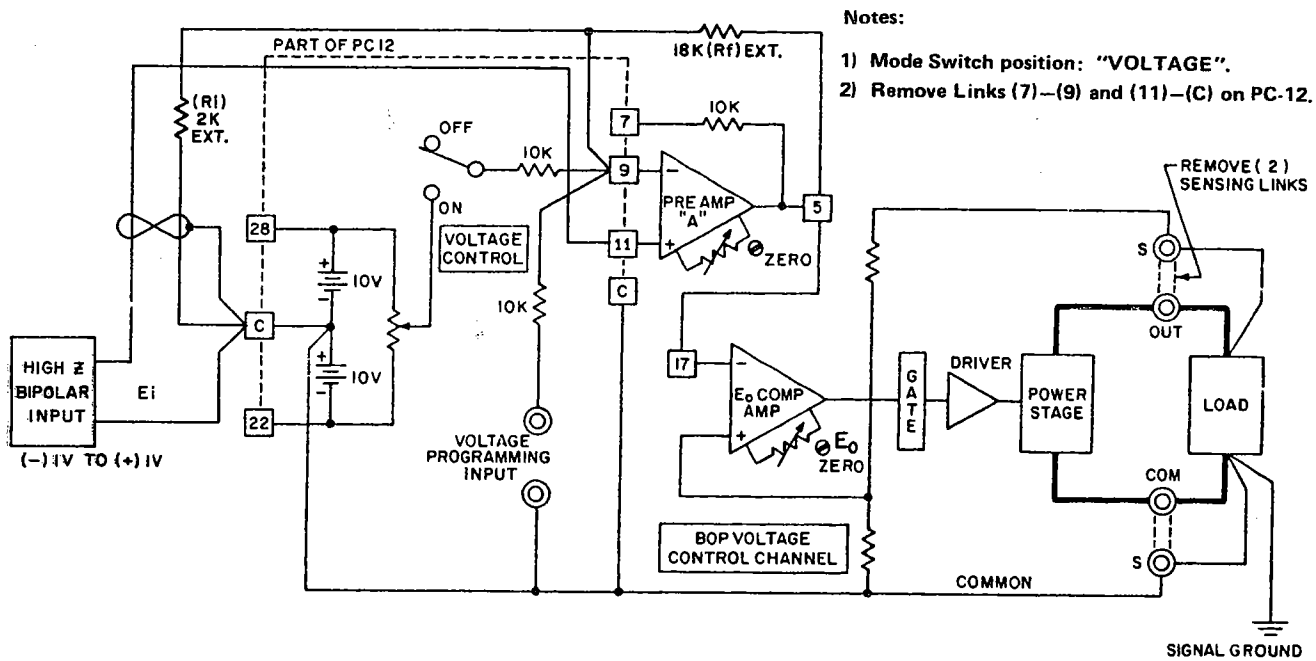

FIG. 3-7 BOP D-C OUTPUT VOLTAGE CONTROL WITH A HIGH IMPEDANCE. (\pm) 1V SIGNAL SOURCE.

3-21 As seen in FIG. 3-7, the original input feedback components of PREAMP "A" have been bypassed and are replaced by external resistors (small, metal film or wire-wound type resistors may be used and connected directly to the REAR PROGRAMMING CONNECTOR terminals as shown). PREAMP "A" is used in the non-inverting configuration. Its output voltage (the necessary BOP control voltage) is given by:

$$E_o (\text{PREAMP "A"}) = E_i \frac{R_f + R_i}{R_i} \quad \text{or} \quad E_o (\text{PREAMP "A"}) = \frac{18\text{K ohm} + 2\text{K ohm}}{2\text{K ohm}} = (\pm) 10\text{V}$$

Consequently, as the BIPOLAR INPUT VOLTAGE (E_i) is controlled from (-) 1V over zero to (+) 1V, the BOP output voltage will follow over its specified range. Calibration of the system can be performed at the programming source, or the PREAMP "A" ZERO control can be used for the low end, while the feedback resistor ($R_f = 18\text{K ohm}$) can be trimmed to calibrate the high end of the range.

3-22 THE BOP AS AN AMPLIFIER

3-23 If, instead of the previously used d-c control signal, an a-c signal voltage is applied to the E_o PROGRAM INPUT, the BOP functions as a bipolar amplifier. As an amplifier, the BOP voltage gain is set on each BOP model so that (as before with the d-c control signal) a bipolar a-c input signal with an amplitude of 0V to 20V (peak-to-peak) will drive the BOP output through its specified (\pm) output voltage range. All other dynamic specifications are given in Section I, Table 1-3.

3-24 The BOP can be used to amplify, sum or scale a variety of waveshapes, some of which are illustrated in FIG. 3-8. All input signals are shown 180° out of phase with their corresponding output waveshapes. The latter can be readily produced in phase (i.e. with the output wave taking the same direction as the input signal) by addressing the non-inverting input of PREAMP "A" instead of the front panel E_o PROGRAM INPUT (Inverting).

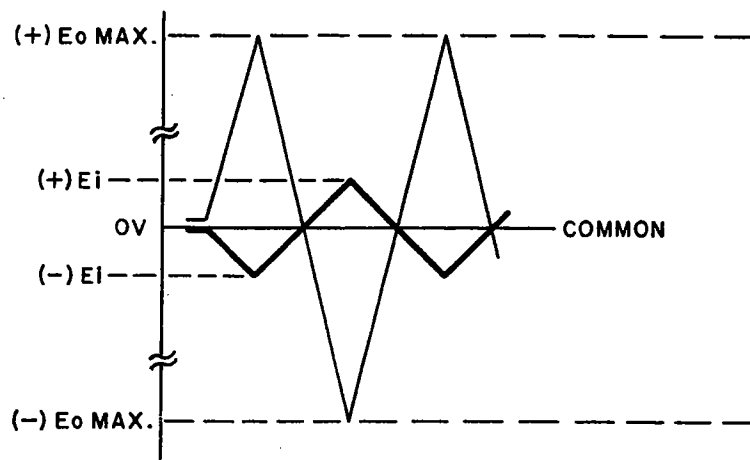
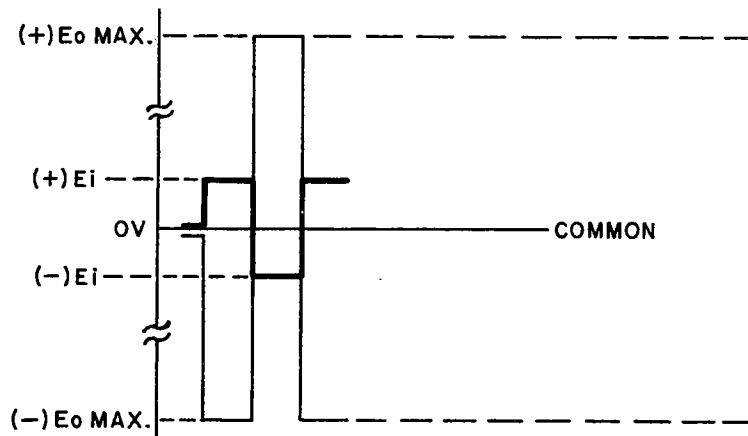
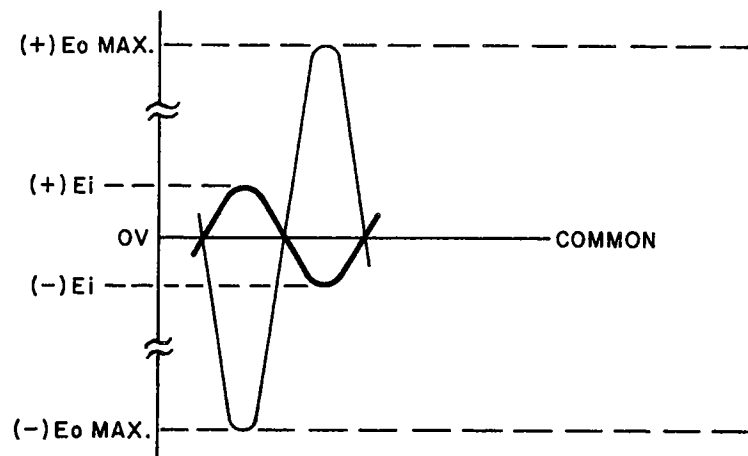

FIG. 3-8 GRAPHS OF POSSIBLE BOP INPUT/OUTPUT WAVE-SHAPES

3-25 The basic programming circuit with which the wave forms shown in FIG. 3-8 can be produced is shown in FIG. 3-9. Since all input signals in FIG. 3-8 are shown with a ± 10 volts amplitude, the basic programming circuit in FIG. 3-9 must be modified if the external signal source cannot produce 10 volts and if the full BOP output voltage swing is required.

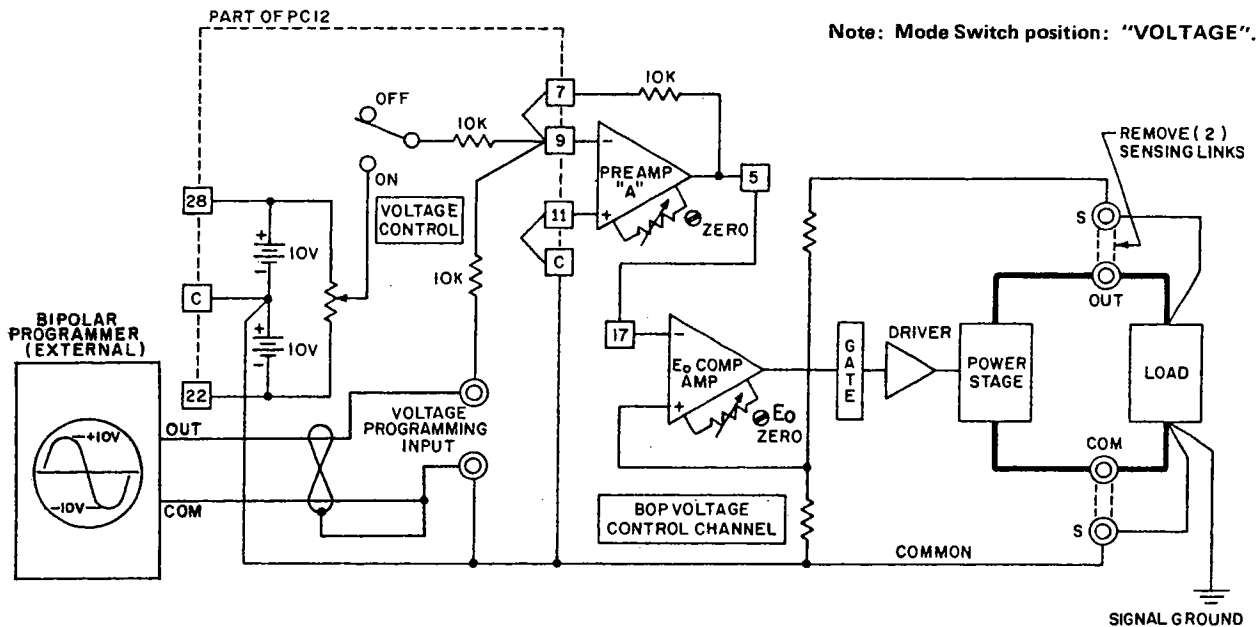

FIG. 3-9 BASIC PROGRAMMING CIRCUIT FOR USE OF THE BOP AS A BIPOLAR AMPLIFIER (VOLTAGE MODE)

3-26 If the EXT. PROGRAMMING SOURCE does not have sufficient amplitude to drive the BOP over its full output range, the gain of PREAMP "A" must be changed from the built-in value (one) to suit the application. To calculate the required components for the new gain requirement, the output equation for PREAMP "A" in the inverting configuration is used:

$$E_{o(\text{PREAMP "A"})} = -E_i (R_f/R_i)$$

where E_o (PREAMP "A") = $\pm 10V$, and the values of R_f and R_i depend on the available amplitude of the programming source. If, for example, a ± 1 volt source is available, the ratio R_f/R_i must be 10, and the two resistor values can be $10K$ and $100K$ respectively. The built-in resistor ($R_i = 10K$) can be retained, and only R_f must be replaced with a $100K$ metal film ($\frac{1}{2}$ watt) unit. The necessary connections are illustrated in FIG. 3-10. Gain control (1 to 10) can be exercised by making R_f a rheostat instead of a fixed resistor.

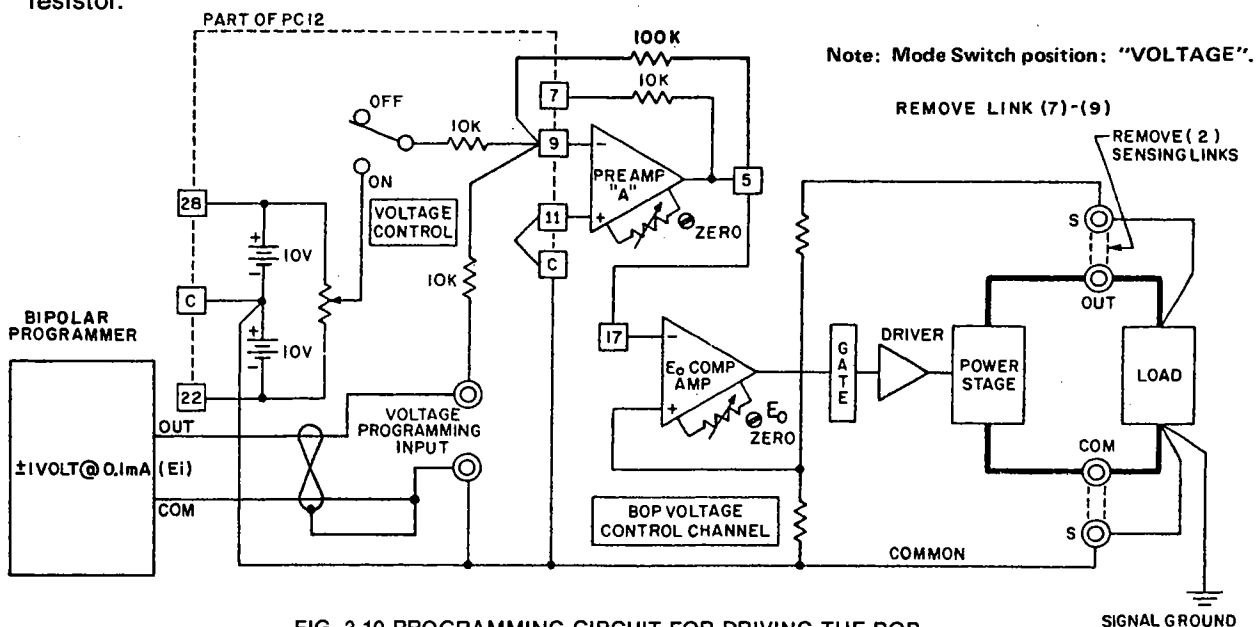

FIG. 3-10 PROGRAMMING CIRCUIT FOR DRIVING THE BOP OUTPUT VOLTAGE WITH A BIPOLAR ($\pm 1V$) SIGNAL

3-27 The non-inverting input of PREAMP "A" is used for applications where the external programming source has a high impedance and/or cannot supply the necessary drive current, or where a positive going output swing is desired for a positive going input signal. The necessary connections are illustrated in FIG. 3-11 for a PREAMP "A" gain of unity (with the built-in value for R_i retained and a short across R_f), although other gain configurations can be chosen, according to the output equation for the non-inverting configuration:

$$E_o \text{ (PREAMP "A")} = \frac{R_f + R_i}{R_i}$$

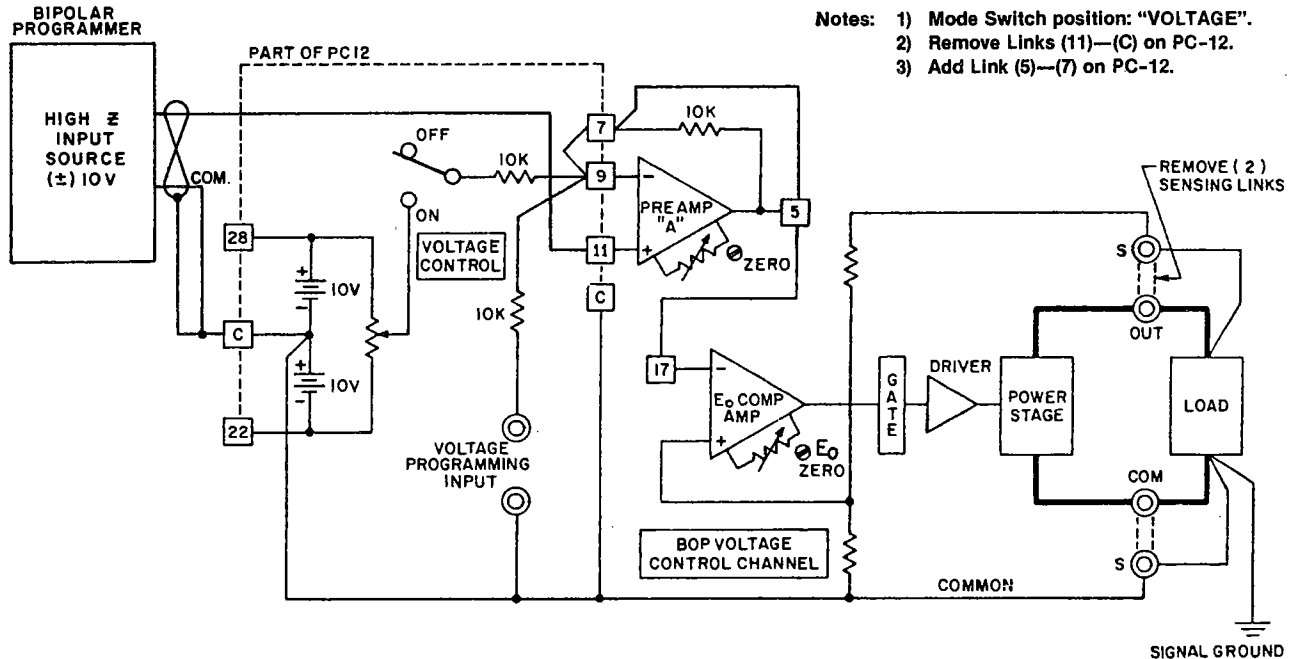

FIG. 3-11 PROGRAMMING CIRCUIT FOR DRIVING THE BOP OUTPUT VOLTAGE WITH A HIGH-IMPEDANCE SOURCE, USING THE NON-INVERTING INPUT OF PREAMP "A".

3-28 BOP OPERATION WITH REMOTE CONTROL OF THE CURRENT CONTROL CHANNEL

3-29 GENERAL: In the local (front panel) control mode, the BOP output current can be controlled by means of the CURRENT CONTROL, with the CURRENT CONTROL SWITCH closed, and the MODE SWITCH in the "CURRENT" position, over the full output range. The control potential (zero to $(\pm)10V$) is applied via PREAMP "B", operating with unity gain, to the I_o COMP. AMP which drives the POWER STAGE with a fixed gain as listed in Section I, Table 1-1. A d-c control signal from zero to $(\pm)10$ volts will, therefore, control the BOP output current through its specified range (refer to FIG. 3-12).

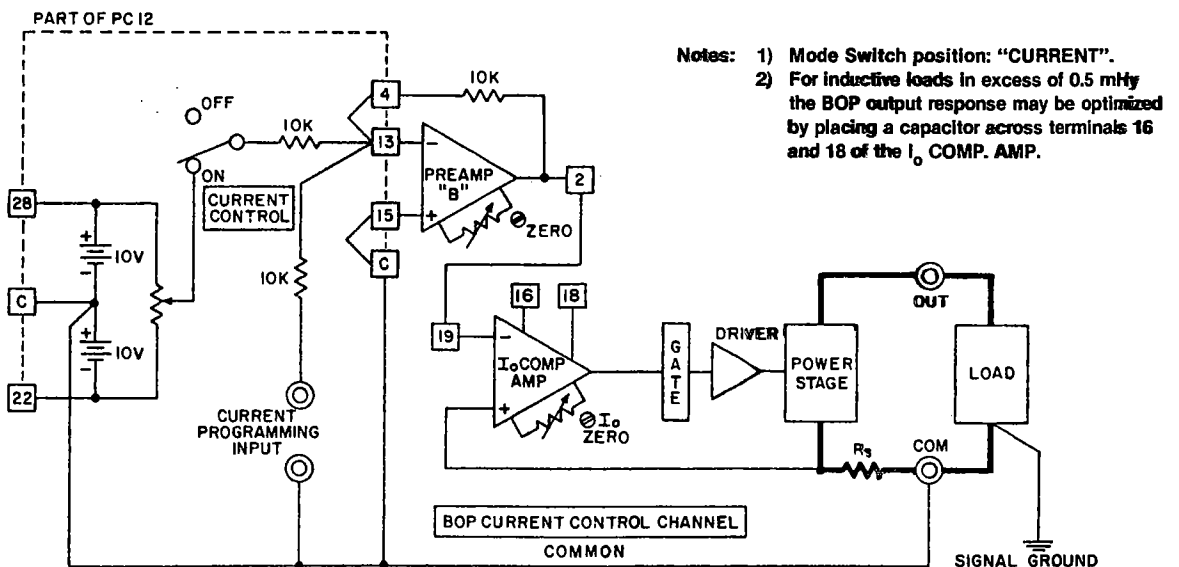

FIG. 3-12 LOCAL (FRONT PANEL) CONTROL OF THE BOP OUTPUT CURRENT WITH THE BIPOLAR CURRENT CONTROL

3-30 REMOTE CONTROL OF THE BOP CURRENT CHANNEL. Since the input signal requirements for the control of the BOP output current are the same as for programming the output voltage, and since the control circuitry of the current channel is almost identical to that of the voltage channel, all programming circuit descriptions for programming the output voltage of the BOP can be applied to current programming. The current programming circuits are illustrated in the following diagrams. Any comments, specifically applicable to current channel programming are noted on the diagrams. **NOTE:** Adjust the "zero" output current point by means of the built-in ZERO control of PREAMP "B" or that of the I_o COMP. AMP.

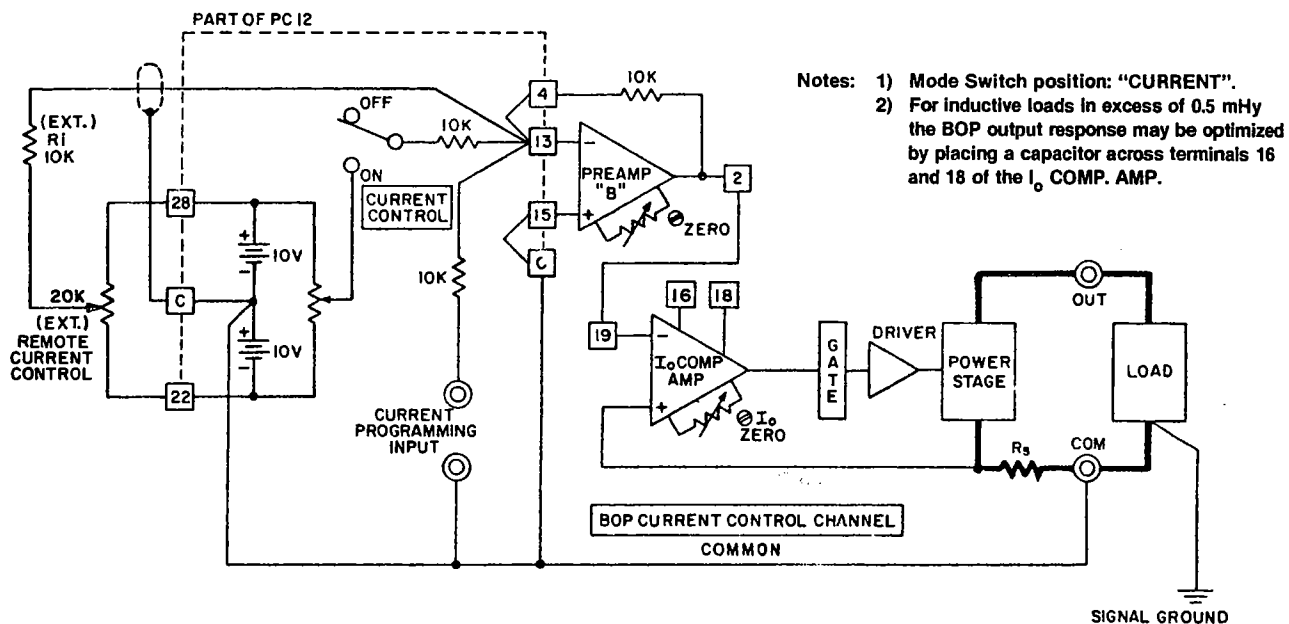

FIG. 3-13 REMOTE POTENTIOMETER CONTROL OF THE BOP OUTPUT CURRENT

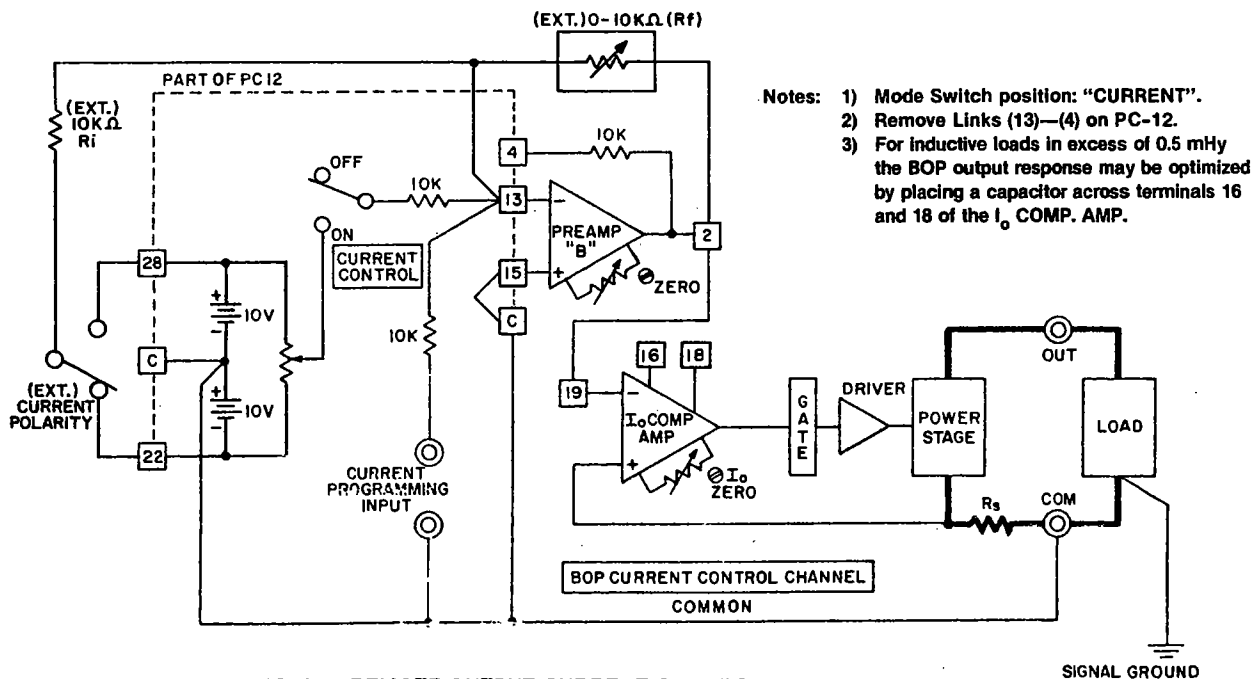

FIG. 3-14 REMOTE OUTPUT CURRENT CONTROL BY MEANS OF A TWO-TERMINAL RESISTANCE.

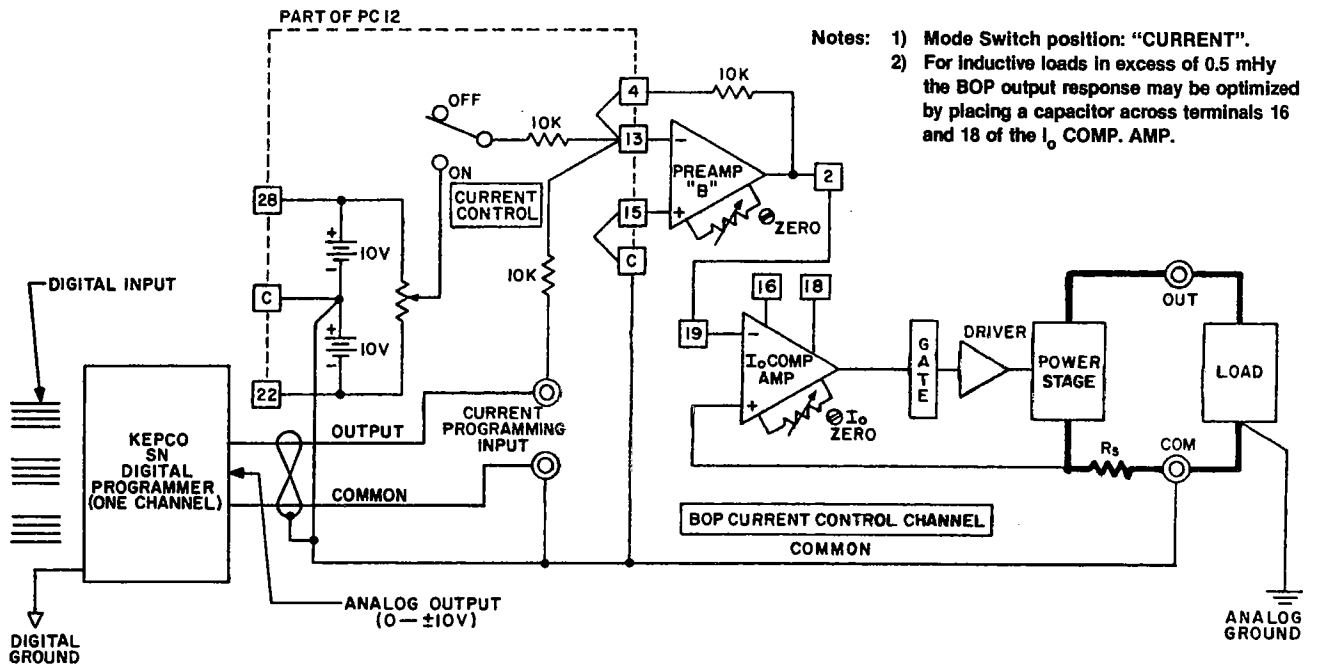

FIG. 3-15 DIGITAL CONTROL OF THE BOP OUTPUT CURRENT

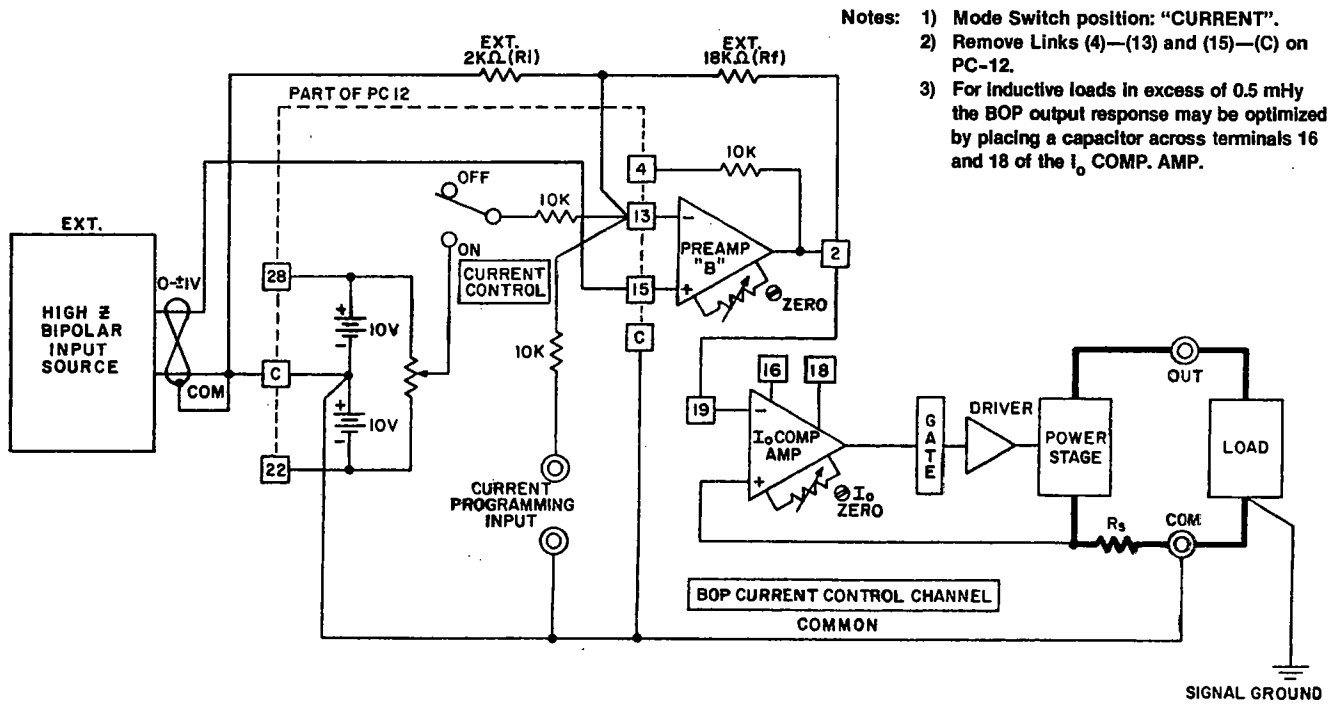

FIG. 3-16 BOP OUTPUT CURRENT CONTROL WITH A HIGH IMPEDANCE (\pm)1 VOLT SIGNAL SOURCE

NOTE: The non-inverting input of the Pre-amplifier is used to prevent loading of the input source.

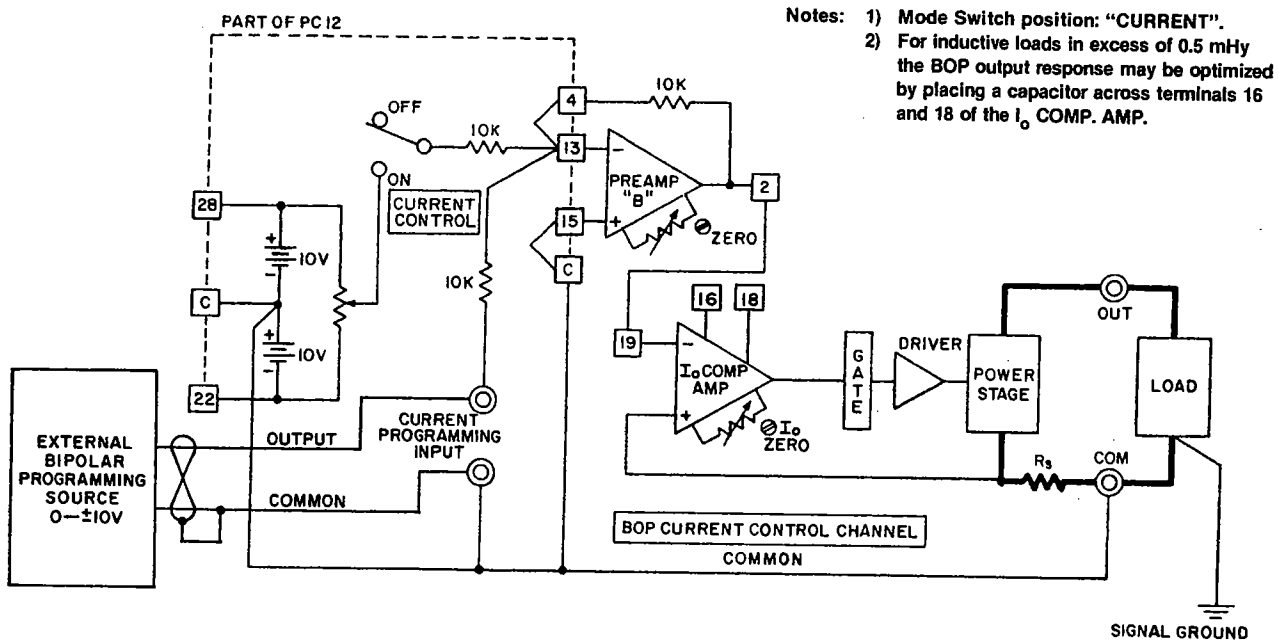

FIG. 3-17 BASIC PROGRAMMING CIRCUIT FOR USE OF THE BOP AS A BIPOLAR CURRENT-STABILIZED AMPLIFIER.

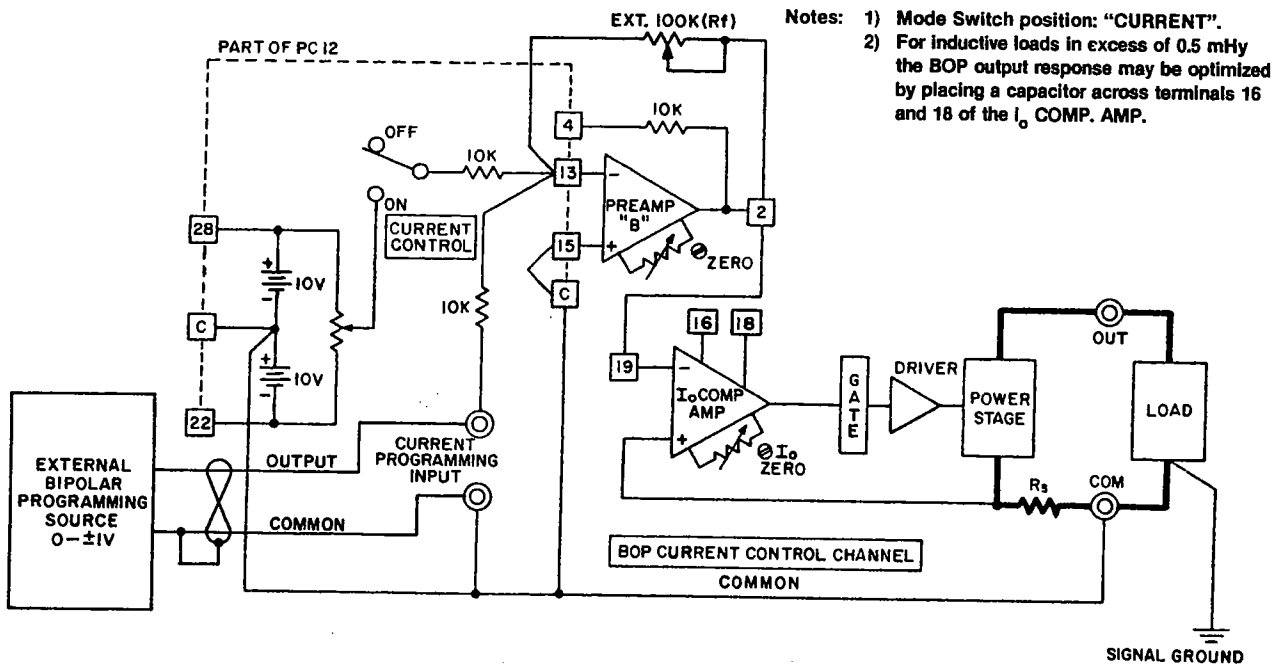

FIG. 3-18 PROGRAMMING CIRCUIT FOR DRIVING THE BOP OUTPUT CURRENT WITH A BIPOLAR SIGNAL LESS THAN $\pm 10V$ (EXAMPLE SHOWN: $\pm 1V$ SOURCE)

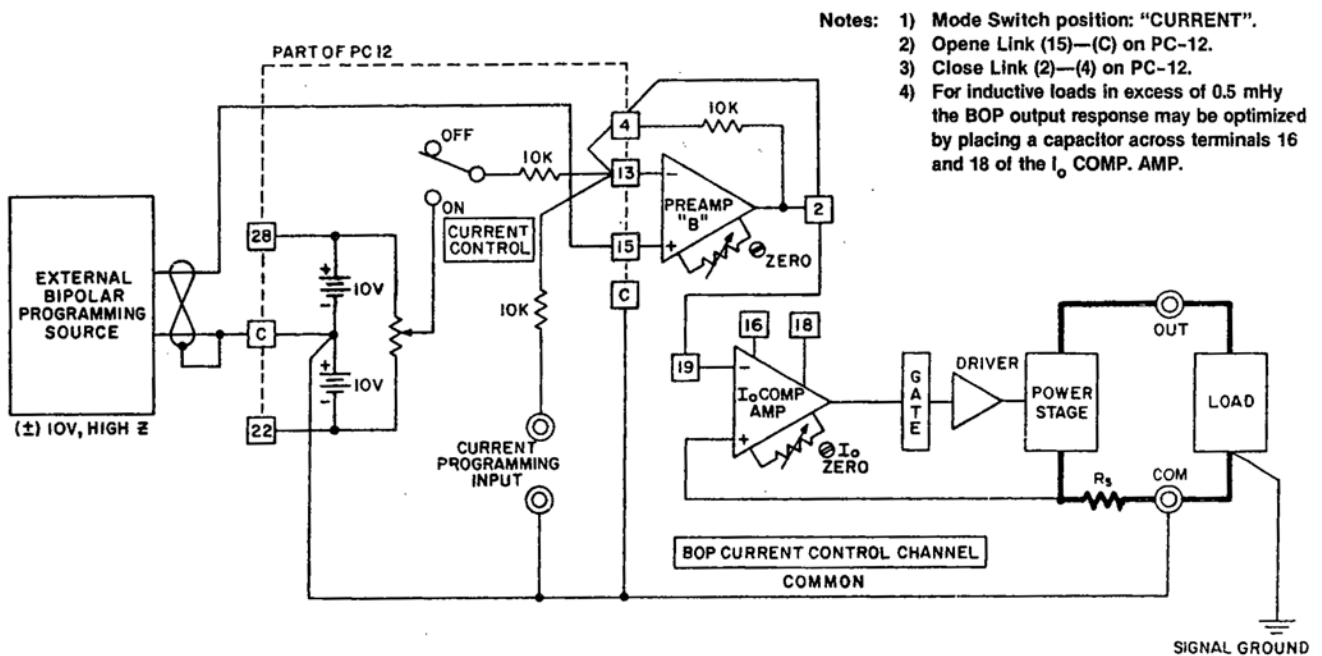

FIG. 3-19 PROGRAMMING CIRCUIT FOR DRIVING THE BOP OUTPUT CURRENT WITH A HIGH IMPEDANCE SOURCE

3-31 REMOTE CONTROL OF THE BOP CURRENT LIMIT (Refer to FIG. 3-35.)

3-32 The output current is sensed by the current sensing resistor (R_s). The voltage drop across R_s is proportional to the output current value, and is amplified by a current sensing amplifier (not shown in FIG. 3-20) and is applied at the input to the (-) I_o LIMIT COMPARISON AMPLIFIER and to the (+) I_o LIMIT COMPARISON AMPLIFIER. In the local (front panel) control mode, as well as in the external control mode, a 0 to 10 volt signal, applied at the inverting inputs of the $\pm I_o$ LIMIT COMPARISON AMPLIFIERS, will control the current limit point over the entire output current range of each BOP model. For the internal (front panel) control mode, the control signal is derived across both 10 volt reference sources, applied by means of the $\pm I_o$ LIMIT controls to the internal $\pm I_o$ LIMIT AMPLIFIERS (both connected as 1:1 voltage followers) and directed to the respective inputs of the $\pm I_o$ LIMIT COMPARISON AMPLIFIERS. In the internal control mode, both $\pm I_o$ LIMIT AMPLIFIERS (EXT) are biased "off" by means of the 15V BIAS source.

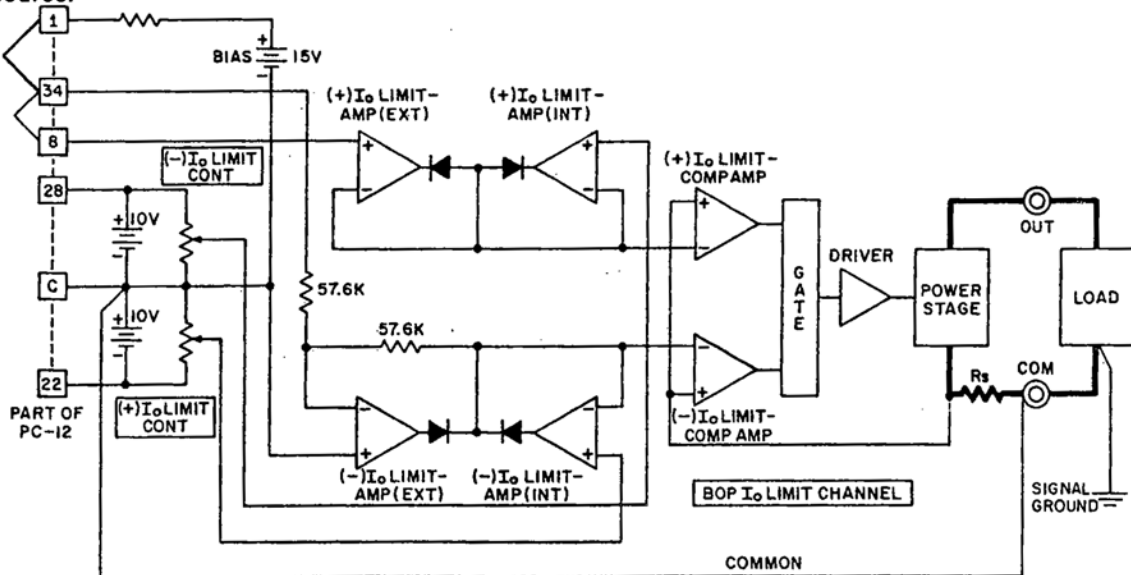

FIG. 3-20 LOCAL (FRONT PANEL) CONTROL OF THE BOP CURRENT LIMIT CIRCUIT

3-33 In the external control mode, the $\pm I_o$ LIMIT AMPLIFIERS (EXT) are disconnected from the 15V BIAS source (jumper 1-8 removed) and external 0-10V control signal is applied to terminals 8 and 34, with reference to COMMON. This control signal will program both, the negative as well as the positive current limit simultaneously and symmetrically over the BOP output current range (See FIG. 3-21). If individual control of the \pm current limits is desired, the jumper 8-34 must be removed and separate control sources must be connected, 0-10 volts to pin 8 for the (+) I_o limit, and 0-10 volts to pin 34 for the (-) I_o limit, both with reference to COMMON (See Fig. 3-22).

NOTE: The front panel $\pm I_o$ LIMIT controls serve as a back-up when external current limit programming is used. The controls should be set to a value slightly larger than the external current limits that are to be programmed.

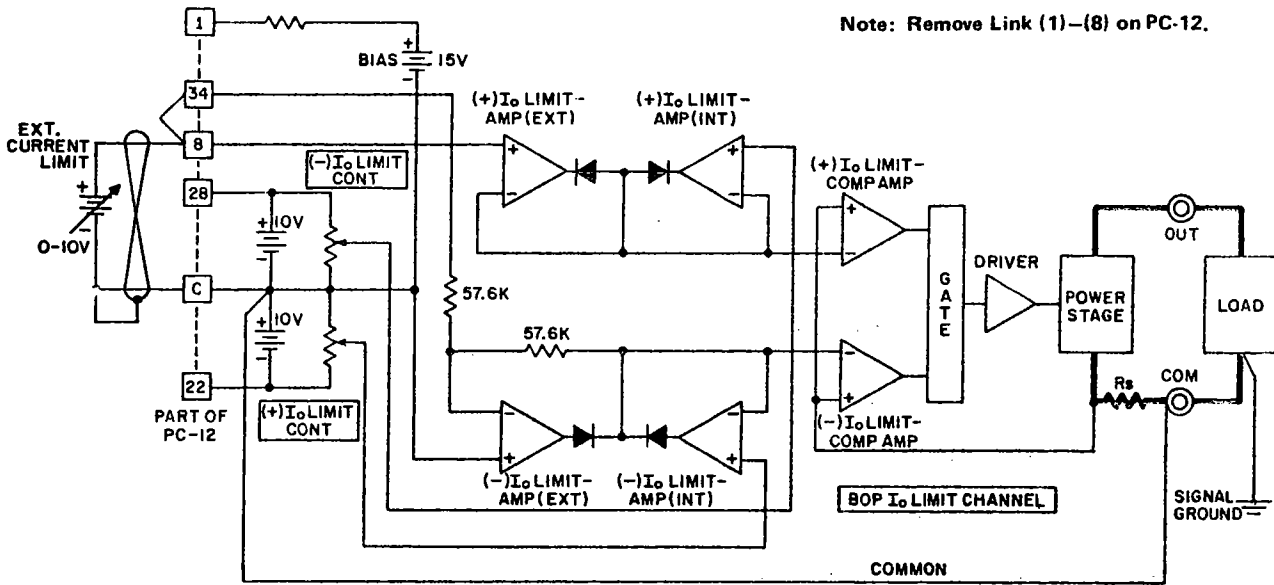

FIG. 3-21 SYMMETRICAL REMOTE CONTROL OF THE BOP CURRENT LIMITS

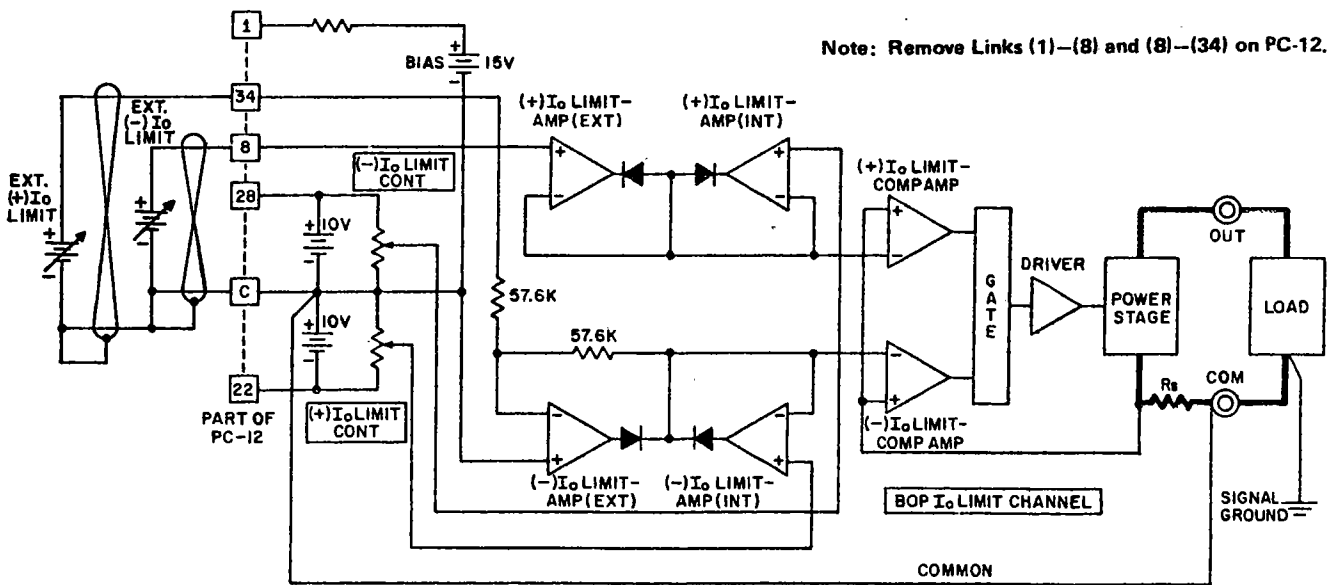

FIG. 3-22 INDEPENDENT REMOTE CONTROL OF THE BOP (+) I_o AND (-) I_o LIMITS

3-34 REMOTE CONTROL OF THE BOP VOLTAGE LIMIT

3-35 The BOP E_o LIMIT CIRCUIT in the local (front panel) control mode is shown in FIG. 3-23. The circuit functions in a similar manner as the I_o LIMIT CIRCUIT described previously (refer to Paragraph 3-31), except that the voltage limit feedback is derived by means of a voltage divider across the BOP output. The \pm voltage limit can be remotely controlled symmetrically with a 0 to 10V d-c source, or the (+) and (-) voltage limit can be controlled independently by individual 0 to 10V d-c sources. The necessary circuit connections are illustrated in FIG.'s 3-24 and 3-25.

NOTE: The front panel VOLTAGE LIMIT CONTROLS serve as a "back-up" when remote controlling the voltage limits on the BOP. The front panel VOLTAGE LIMIT CONTROLS should be set to their maximum positions if full range remote control of the BOP voltage limit is desired.

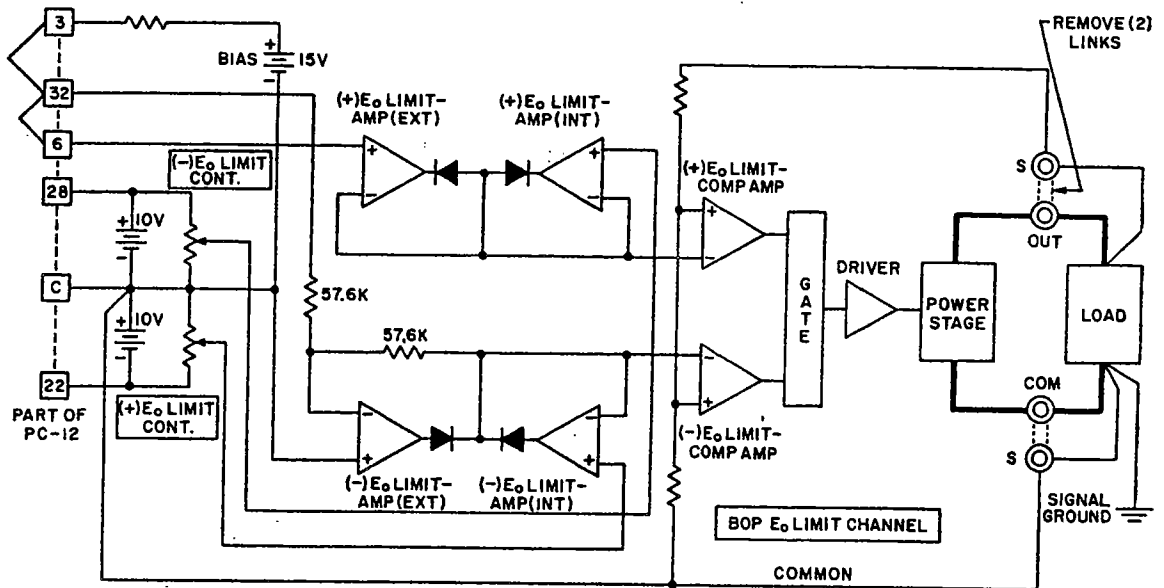

FIG. 3-23 LOCAL (FRONT PANEL) CONTROL OF THE BOP VOLTAGE LIMIT CIRCUITS

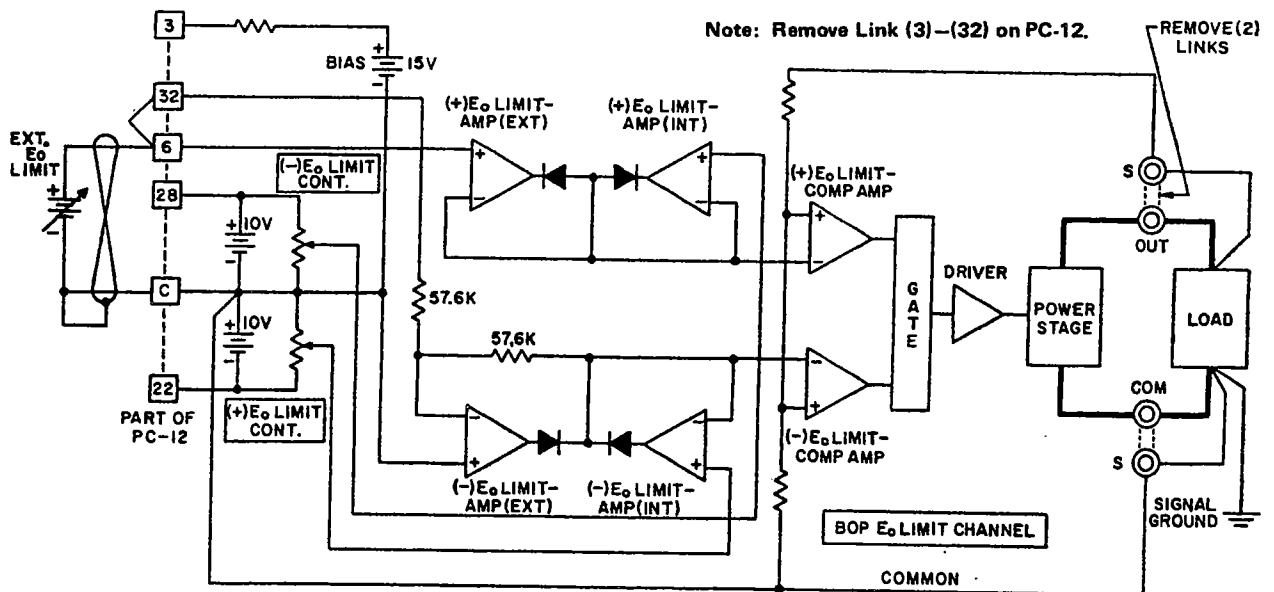

FIG. 3-24 SYMMETRICAL REMOTE CONTROL OF THE BOP VOLTAGE LIMIT CIRCUITS

Note: Remove Links (3)-(32) and (6)-(32) on PC-12.

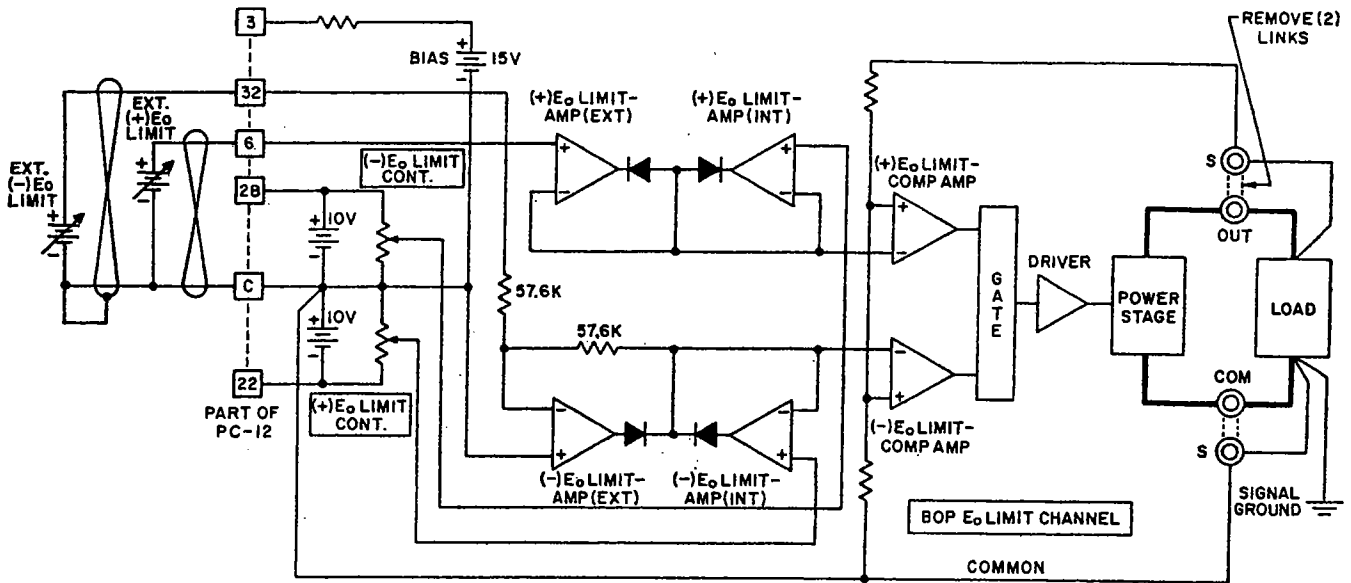

FIG. 3-25 INDEPENDENT REMOTE CONTROL OF THE BOP
(+) E_o AND (-) E_o VOLTAGE LIMIT CIRCUITS

3-36 SERIES AND PARALLEL CONNECTION OF BOP POWER SUPPLIES.

3-37 GENERAL. Voltage sources, such as batteries, cells or stabilized d-c power supplies can be readily series-connected, but normally, they can not be paralleled. Even minute differences in their terminal potential would cause large, damaging circulating currents. By complementary reasoning, current sources can easily be paralleled, but not series-connected. Fortunately, with practical stabilized power supplies these difficulties can be overcome in various ways.

3-38 There are two basic methods which are commonly used for the series or parallel connection of stabilized d-c power supplies. The first method is the "AUTOMATIC" series or parallel connection by which the power supply outputs are simply connected together, in series or parallel, as required. The individual supplies can now be adjusted to the load requirements. The "AUTOMATIC" method presents no problems as long as it is confined to SERIES connection with voltage sources, or to PARALLEL connection with current sources. As far as the BOP is concerned, the only thing to remember is to place the MODE switch into its proper position:

AUTO-SERIES CONNECTION: All BOP MODE SWITCHES TO "VOLTAGE"

AUTO-PARALLEL CONNECTION: All BOP MODE SWITCHES TO "CURRENT".

3-39 The second method for series or parallel connection of two or more units is the "MASTER/SLAVE" configuration, by which a designated MASTER supply controls the output of one or more SLAVE units. This control method permits control of the common output by a single unit - the MASTER. Since this method presents the least problems for either series or parallel connections and since it is readily implemented with BOP power supplies, it is the recommended method for this kind of operation and will be fully described below.

3-40 MASTER/SLAVE SERIES CONNECTION OF TWO BOP SUPPLIES, PROCEDURE:

- 1) Connect the BOP supplies as shown in FIG. 3-26. Set the MODE switches and the VOLTAGE CONTROL switches as directed in the set-up diagram, FIG. 3-26. Load-wire size should be as large as practicable and load-wire pairs should be twisted to keep the d-c resistance, as well as the inductance as low as possible. Use shielded cable for connecting the coupling resistor (R_T). Connect shield to common ground. Either the positive, or the negative output side of the system can be grounded.
- 2) Both BOP power supplies should be connected to the power line using a common circuit breaker. Alternatively, the BOP Circuit-Breaker Control Circuit, as described in Section IV, paragraph 4-25 can be used to interconnect both BOP's in such a way, that if one of them should fail, the other one is automatically shut down also.
- 3) The coupling resistor (R_T) should be either a wire-wound or a metal film unit with a low temperature coefficient. It is calculated by:

$$R_T \text{ (Kohms)} = E_{OM} \text{ (MAX) Volts} - 10 \text{ Volts,}$$

where E_{OM} (MAX.) is the rated maximum output voltage of the BOP MASTER supply. This value of R_T will be able to drive the BOP SLAVE unit to its (\pm) maximum output voltage, as the BOP MASTER is controlled through its range.

- 4) Following the set-up procedures as described above, turn BOP's "on" and commence operation. The system as shown in the set-up diagram (FIG. 3-26) operates in the Voltage Mode, since the MASTER MODE switch is in "VOLTAGE" position. For operation in the Current Mode, transfer the MASTER MODE switch to "CURRENT".

3-41 MASTER/SLAVE PARALLEL CONNECTION OF TWO BOP SUPPLIES, PROCEDURE:

- 1) Connect the BOP supplies as shown in FIG. 3-27. Set the MODE switches and the VOLTAGE and CURRENT CONTROL switches as directed in the set-up Diagram, FIG. 3-27. Load-wire size should be as large as practicable and load-wire pairs should be twisted to keep the d-c resistance, as well as the inductance, as low as possible. Use shielded cable for the drive signal connection between the BOP's. Connect the shield to common ground. Either the positive or the negative output side of the system can be grounded.
- 2) Both BOP power supplies should be connected to the power line using a common circuit breaker. Alternatively, the BOP Circuit-Breaker Control Circuit, as described in Section IV, paragraph 4-25 can be used to interconnect both BOP's in such a way, that if one of them should fail, the other one is automatically shut down also.
- 3) Following the set-up procedure as described above, turn BOP's "on" and commence operation. The system as shown in the set-up diagram (FIG. 3-27) operates in the Voltage Mode, since the MASTER MODE switch is in "VOLTAGE" position. For operation in the current mode, transfer the MASTER MODE switch to "CURRENT".

3-42 MASTER/SLAVE SERIES OR PARALLEL CONNECTIONS FOR MORE THAN TWO BOP POWER SUPPLIES.

The concept of series connecting or paralleling two BOP power supplies can be extended to include interconnection of more than two BOP units. The limitations applying to the series-connection is the isolation limit of the BOP itself (500V), while that of the parallel connection is the load-wire size required for larger and larger loads.

- 3-43 To extend the concept of series connection to more than two BOP units, refer to FIG. 3-26. The BOP unit now designated the SLAVE becomes the new MASTER for the next BOP unit to be added and so on, up to the desired number of BOP's in series. Simply place the BOP outputs in series and connect a further coupling resistor (R_T) from the *present* SLAVE, terminal [C] to the *new* SLAVE, front panel VOLTAGE PROGRAMMING INPUT. Place the MODE switch on the BOP added to the series combination to VOLTAGE and the VOLTAGE CONTROL switch OFF.
- 3-44 To add more BOP units to the parallel system shown in FIG. 3-27, simply place the output leads of the unit to be added in parallel to the load. Set its MODE switch to CURRENT and its CURRENT CONTROL switch to OFF. Now connect another shielded cable from the BOP designated MASTER in FIG. 3-27, terminal [10] on PC-12, to the new BOP to be added, PC-12 terminal [19].
- 3-45 All series/parallel systems of BOP power supplies should be interconnected via the BOP Circuit Breaker Control Circuit, as described in Section IV, paragraph 3-83. This failure detection loop will shut down *all* BOP units in a series or parallel system if one of them fails.

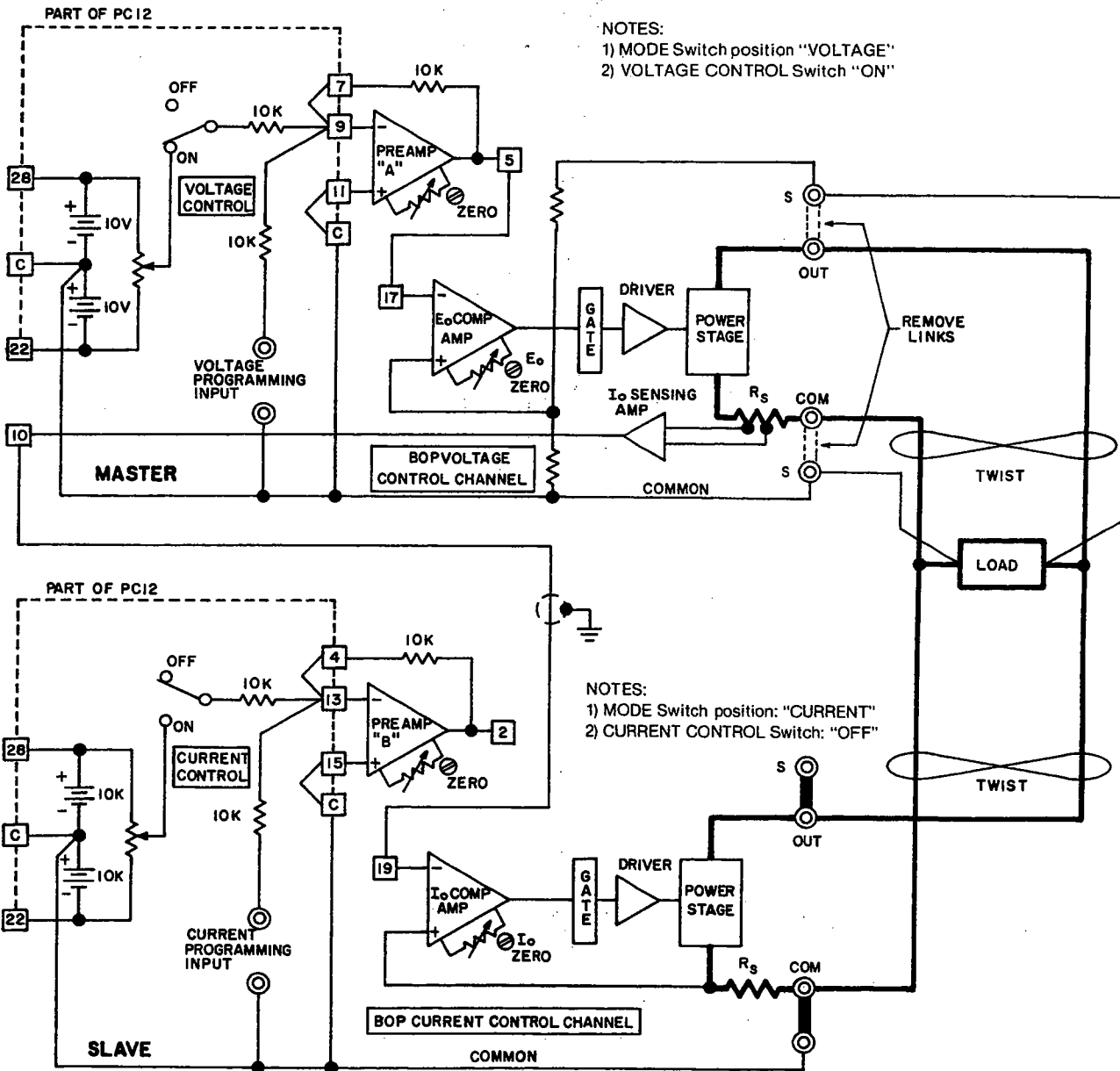

FIG. 3-27 MASTER/SLAVE PARALLEL CONNECTION OF TWO BOP POWER SUPPLIES

3-46 DIGITAL CONTROL OF BOP POWER SUPPLIES.

- 3-47 The output of the BOP power supply, that is, the output voltage and the output current limit, with the BOP in the Voltage Mode of operation, or the output current and the output voltage limit with the BOP in the Current Mode of operation, may be digitally controlled by means of a Kepco Digital Programmer. Kepco Digital Programmers accept data from serial or parallel data buses and convert this data to an analog output voltage which, in turn, controls the output parameters of the connected BOP power supply.
- 3-48 The following paragraphs present a brief overview of the available Kepco programming interfaces. Each of these devices is delivered with its own instruction manual, which provides the necessary details for operation, programming and maintenance.
- 3-49 Common features of all Kepco programming interfaces include optical isolation of digital input and analog output, dual, selectable output ranges of 0 to 1V or 0 to 10V, and output polarity control, making them suitable for unipolar or bipolar power supply programming.
- 3-50 Since the output of all Kepco Digital Programmers is a linear, analog voltage of either 0 to 1V, or 0 to 10V, depending on the range selected, all programming examples in this section (Section III) which show an external programming source may be used for digitally programming the BOP power supply. Although the given examples show single function applications only, simultaneous programming of several output functions, such as voltage control with current limit or current control with voltage limit may be performed with all digital programmers having more than one output channel.

3-51 KEPCO DIGITAL PROGRAMMERS.

3-52 The SN GROUP consists of the following models:

	MODEL SN 488-				MODEL SN 500-			
	121	122	031	032	121	122	031	032
CHANNELS	1	2	1	2	1	2	1	2
INPUT DATA CODE	ASCII/HEX		ASCII/BCD		ASCII/HEX		ASCII/BCD	
RESOLUTION	12 bit		3 DIGIT		12 bit		3 DIGIT	
OUTPUT	0-1V or 0-10V		0-1V or 0-10V		0-1V or 0-10V		0-1V or 0-10V	

3-53 SN 488 SINGLE OR DUAL CHANNEL DIGITAL PROGRAMMERS

3-54 The Kepco SN 488 Programmers were designed to operate on the GPIB (IEEE 488) bus. Once addressed by the controller with their unique, presettable address code and placed in the Data Mode, they accept a sub-set of the 7-bit ASCII code ("0" through "9", "A" through "F") having the following data format and sequence: NCVVV (ASCII)

Byte 1 — N = Channel Select, "1" or "2".

Byte 2 — C = Control Character: C = "0" Pos. Out, High Range

Byte 3 — VVV = Output Volts C = "1" Neg. Out, High Range

Byte 4 — as a percentage of full C = "2" Pos. Out, Low Range

Byte 5 — scale C = "3" Neg. Out, Low Range

3-55 Data transfer is byte-serial. The output voltage bytes (3 to 5) may be encoded in hexadecimal notation (000 to FFF) for models SN 488-121 and SN 488-122 and in BCD notation (000 to 999) for SN 488-031 and SN 488-032. The data transfer time is approximately 60µsec.

3-56 SN 500 SINGLE OR DUAL CHANNEL DIGITAL PROGRAMMERS

3-57 The Kepco SN 500 programmers were designed to operate on bit parallel data buses. The SN 500 accepts either positive or negative logic (selectable) on its input port. The SN 500 programmer is terminated with a 50-pin edge connector with pin-outs as shown below (See paragraph 3-59). The magnitude field input data may be BCD for SN 500-021 and SN 500-022 or BINARY for SN 500-121 and SN 500-122.

3-58 Data transfer is bit-parallel and is controlled by the STROBE pulse and the internally created BUSY signal following each STROBE (externally applied, 2 μ sec min.). Data transfer time is approximately 35 μ sec., although the data lines are free for other purposes, following the 2 μ sec. STROBE.

3-59 INPUT/OUTPUT CONNECTOR, PIN-OUT.

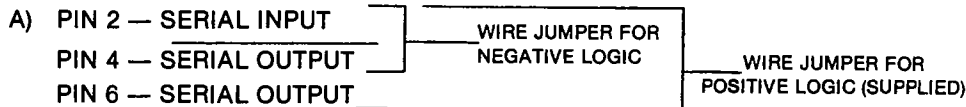

Pins 2, 4 and 6 serve to select either POSITIVE LOGIC (L = 0, H = 1) by placing the jumper from pin 2 to pin 6, or NEGATIVE LOGIC (L = 1, H = 0) by placing the jumper from pin 2 to pin 4. The SERIAL INPUT may also be used for other purposes and may be synchronized by means of the SHIFT CLOCK output.

- B) PIN 8 — RANGE, CHANNEL 1 L = HIGH RANGE (0-10V) H = LOW RANGE (0-1V)
 PIN 10 — POLARITY, CHANNEL 1 L = POSITIVE OUTPUT H = NEGATIVE OUTPUT
 PIN 12 — RANGE, CHANNEL 2 L = HIGH RANGE (0-10V) H = LOW RANGE (0-1V)
 PIN 14 — POLARITY, CHANNEL 2 L = POSITIVE OUTPUT H = NEGATIVE OUTPUT

All four RANGE and POLARITY selection terminations have been provided for manual preselection of range and polarities on both channels. If RANGE and POLARITY are machine controlled, only pins 8 and 10 are needed, since a CHANNEL SELECTOR command is required to preselect each channel.

NOTE: Pin 12 should be connected to pin 8 while pin 14 should be connected to pin 10. If, however, the application calls for fixed polarity and range, the appropriate pins can be hardwire according to the requirements.

C) MAGNITUDE FIELD, DATA INPUT PINS:

PINS:	16	18	20	22	24	26	28	30	32	34	36	38
BITS:	12	11	10	9	8	7	6	5	4	3	2	1
	MSB											LSB
DECADE	10^{-1}				10^{-2}				10^{-3}			
BCD	8	4	2	1	8	4	2	1	8	4	2	1

- D) PIN 40 D-C LOGIC SUPPLY OUTPUT, 5V at 20mA maximum. May be used to connect pull-up resistors for establishing pre-wired logic states or to drive external logic within the given rating.
- E) PIN 42—STROBE. The negative going edge of the strobe signal (H-L) enables the loading of the Temporary Storage Registers with the data presented on the data pins. *The minimum duration of STROBE must be 2 μ sec.*
- F) PIN 44—BUSY (H = BUSY, L = NOT BUSY). This output delivers a status signal to the bus. On the first clock transition (H-L), following the STROBE signal, the BUSY line goes high (H) and remains high until the first clock transition (H-L) following data transfer (approximately 35 μ sec.), indicating the SN 500 is ready to accept new data.
- G) PIN 46—CHANNEL SELECT (H = CHANNEL 1, L = CHANNEL 2).
- H) PIN 48—SHIFT CLOCK. This output is used to synchronize the external SERIAL INPUT, if used.
- J) PIN 50—SHIELD (CHASSIS). Chassis and Case connection of the SN 500.
- K) PINS 1 thru 49 (Odd No.'s): LOGIC GROUND and LOGIC SUPPLY COMMON.

3-60 THE SNR PROGRAMMING SYSTEM

- 3-61 The Kepco SNR 488 Programming System consists of a full-rack housing with built-in interface card for the GPIB (IEEE 488) bus and several optional plug-in cards, each able to control 2 channels with a common connection.
- 3-62 The Model SNR 488-8 housing can accommodate eight (8) plug-in cards, while Model SN 488-4 seats four (4) cards and in addition has room for either two Kepco quarter-rack or one half-rack size power supply. Each housing is connected to the bus via a single cable, which serves all plug-in cards. Each SNR housing has a device address selector switch, while individual cards addresses are handled by means of the input command string to the SNR and a presetable address selector switch for each card.
- 3-63 SNR 488 programmers, when connected to the bus, addressed by the controller with their unique, presetable address code and placed in the data mode, accept a sub-set of the 7-bit ASCII code ("0" through "9", "A" through "F" and "="), having the following data format and sequence: N = CVVVIII, each symbol representing an ASCII character, for a total of 9 bytes:

Byte 1 — N = Address Byte, card address

Byte 2 — "Equal" sign, delimiter

Byte 3 — Control Character C: determines RANGE and POLARITY for both, CHANNEL A and CHANNEL B
Coded with ASCII characters "0" through "F", see SNR-488 Instruction Manual

Byte 4 }
Byte 5 } VVV = Output Quantity, Channel A
Byte 6 }

Byte 7 }
Byte 8 } III = Output Quantity, Channel B
Byte 9 }

- 3-64 Data transfer on the GPIB (IEEE 488) is byte-serial. The output quantity bytes (VVV and III) are encoded in hexadecimal notation for Model SN 488-B cards and in BCD notation for Model SN 488-D cards. Encoding ranges are 000 to FFF and 000 to 999 respectively. Data transfer time is approximately 60 μ sec.

3-65 THE BIT PROGRAMMING CARDS

- 3-66 These cards are inserted into an existing slot in the BOP series of Kepco power supplies. They convert the BOP into a stand-alone, digitally programmable power source. The card may be field-installed by the user, or the BOP may be ordered with the BIT card factory installed.
- 3-67 There are four (4) BIT models available. Two (2) of them, Models BIT 488-B and BIT 488-D are for operation of the BOP on the GPIB (IEEE 488) bus. The other two (2), Models BIT 500-B and BIT 500-D are for operation of the BOP on parallel data buses. Each BIT card controls the BOP's main channel and limit channel. Depending on the BOP's operating mode selection, either Output Voltage and Current Limit (Voltage Mode) or Output Current and Voltage Limit (Current Mode) can be controlled simultaneously.

3-68 THE BIT 488 DUAL CHANNEL DIGITAL PROGRAMMING CARDS.

- 3-69 The BIT 488 programming cards were designed to operate on the GPIB (IEEE 488) bus. Once addressed by the bus controller with their unique, presetable address code, they are placed in the Data Mode and accept a subset of the 7-bit ASCII code ("0" through "F").
- 3-70 The BIT 488 card requires the following data format and sequence: CMMMLL (ASCII).

Byte 1 — Control Character: C - determines BIT output range, polarity and BOP operating mode.
ASCII DIGITS "0" through "7". See BIT 488 Instruction Manual

Byte 2 } Main Channel
Byte 3 } Output
Byte 4 }
Byte 5 } Limit Channel
Byte 6 } Output

- 3-71 Data transfer is byte-serial. The Main channel field (MMM) may be encoded in hexadecimal notation (000 to FFF) for BIT 488-B models or in BCD notation (000 to 999) for BIT 488-D models. Data transfer time is approximately 60 μ sec.

3-72 THE BIT 500 DUAL CHANNEL DIGITAL PROGRAMMING CARDS. The BIT 500 programming cards were designed to operate on bit-parallel data buses. These cards expect either positive or negative logic (selectable) at their input port. Once installed in the BOP, they are terminated by a 50-pin edge connector with pin-outs as shown in paragraph 3-74. The magnitude field for the MAIN CHANNEL and for the LIMIT CHANNEL is to be binary encoded for Model BIT 500-B and BCD encoded for Model BIT 500-D.

3-73 Data transfer is bit-parallel and is controlled by the externally applied STROBE pulse (2 μ sec. min) and the internally created BUSY signal, following each strobe. Data transfer time is approximately 35 μ sec., although the data lines are free for other purposes, following the 2 μ sec. STROBE.

3-74 INPUT/OUTPUT CONNECTOR, PIN-OUT FOR BIT 500.

NOTE: All input commands are with reference to LOGIC GROUND.

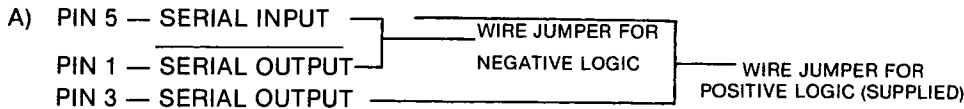

Pins 1, 3 and 5 serve to select either POSITIVE LOGIC (L = 0, H = 1) by placing the jumper from pin 5 to pin 3, or NEGATIVE LOGIC (L = 1, H = 0), by placing the jumper from pin 5 to pin 1. The selection of POSITIVE or NEGATIVE logic applies only to DATA, POLARITY and RANGE signals.

B) Pin 17—Control (LOC/REM), H = REMOTE, L = LOCAL. Selects either local (FRONT PANEL) or remote (BUS) control of the BOP.

NOTE: THIS PIN MUST BE HIGH (H) FOR REMOTE, (BUS) CONTROL OF THE BOP.

C) Pin 15—MODE (V/I), H = CURRENT Mode, L = VOLTAGE Mode. Determines BOP operating mode. Designates the Main Channel to Voltage Control, Limit Channel to Current Limit Control.

D) Pin 13—RANGE (HI/LO), H = Low Range (0-1V), L = High Range (0-10V). Selects Main Channel output range.

E) Pin 11—POLARITY (+/-), H = Negative, L = Positive, Selects Main Channel output polarity with reference to ANALOG GROUND.

F) Pin 9 d-c LOGIC SUPPLY OUTPUT, 5V at 20 mA maximum. May be used to connect pull-up resistors for establishing pre-wired logic states or to drive external logic within the given ratings.

G) Pin 7— $\overline{\text{STROBE}}$. The negative going edge signal (H-L) enables the loading of the Temporary Storage Registers with the data presented on the data pins. The minimum duration of $\overline{\text{STROBE}}$ must be 2 μ sec.

H) Pin 47—BUSY (H = busy, L = not busy). This output delivers a status signal to the bus. On the first clock transition (H-L), following the $\overline{\text{STROBE}}$ signal, the BUSY line goes high (H) and remains high until the first clock transition (H-L), following data transfer (approximately 50 μ sec.), indicating the BIT 500 is ready to accept new data.

J) Pin 49—SHIELD (CHASSIS). Chassis and Case connection of the BIT 500.

K) Pins 37,39,41,43,45 LOGIC GROUND, COMMON, 5V LOGIC SUPPLY.

L) MAGNITUDE FIELD, MAIN CHANNEL

PINS:	2	4	6	8	10	12	14	16	18	20	22	24
BITS: (BIT 500-B)	12	11	10	9	8	7	6	5	4	3	2	1
	MSB											LSB
DECADE (BIT 500-D)	10^{-1}				10^{-2}				10^{-3}			
BCD	8	4	2	1	8	4	2	1	8	4	2	1

M) MAGNITUDE FIELD, LIMIT CHANNEL

PINS:	34	36	38	40	42	44	46	48
BITS: (BIT 500-B)	8	7	6	5	4	3	2	1
	MSB							LSB
DECADE (BIT 500-D)	10^{-1}				10^{-2}			
BCD	8	4	2	1	8	4	2	1

3-75 THE KEPSCO MODEL TLD 488-16 INTERACTIVE DIGITAL PROGRAMMER.

- 3-76 The Kepco Model TLD 488-16 was designed to operate on the GPIB (IEEE 488) bus as a LISTENER/TALKER. It is configured as a standard rack card-cage, containing a micro-computer with bus interface, status monitor for catastrophic error reporting via a discrete line to the controller and an on-board parallel peripheral interface for optional load isolation relays.
- 3-77 The Kepco TLD 488-16 accepts up to four plug-in programming boards, either the Kepco Model TL 488-4A for Kepco ATE power supplies, or the TL 488-4B for Kepco BOP power supplies, or a mixture of these two models. Each board can control up to four (4) power supplies, so that a maximum of sixteen (16) power supplies may be digitally programmed via the TLD output ports, using only a single GPIB bus connection.
- 3-78 When using TL 488-4B programming cards for BOP power supplies, each BOP must be equipped with an optional Kepco interface card, Model PCA X-3, which is installed inside the BOP. When using TL 488-4A programming cards for ATE power supplies, each ATE is connected to the TLD 488-16 via a unique interface connector, Model PCA X-X, model number depending on ATE model designation. These PCA devices have the function of informing the TLD about the parameters of the connected power supplies.
- 3-79 Communications between the TLD 488-16 and the system controller in the COMMAND mode follow the GPIB (IEEE 488) protocol, with the TLD 488-16 implementing the following functions:

GPIB FUNCTION	SUBSET SYMBOL	COMMENTS
Source handshake	SH1	—
Acceptor handshake	AH1	—
Talker	T6	Basic talker, serial poll, unaddress if MLA
Listener	L4	Basic listener unaddress if MTA
Service request	SR1	—
Device clear	DC1	—

- 3-80 Communications between the TLD 488-16 and the system controller in the DATA mode, use elements of the CONTROL INTERFACE INTERMEDIATE LANGUAGE (CIIL). The statement syntax and operation codes of CIIL are encoded using the 7-bit ASCII character set and are briefly described below⁽¹⁾.

1) FNC - function op-code

SYNTAX: FNC DCS :CHnn

This operator, with the operands DCS and :CHnn is used at the start of each set-up sequence. The "DCS" operand is a CIIL "noun" and describes the type of device being set-up (DCS = d-c source, power supply). The :CHnn operand is used in the set-up of all devices and indicates the port or channel number of the TLD 488-16 in our case.

2) SET - set-up code

SYNTAX: SET VOLT (value nnn)

The SET command string is used to specify a characteristic of the device "DCS" specified in the FNC command string. The first operand (VOLT) indicating that characteristic. Possible operands for this field when programming the TLD 488-16 are: VOLT, CURR, VLTL, CURL. The second operand (value) which may be encoded in ASCII integer, decimal or scientific notation.

3) STA - status op-code

SYNTAX: STA

This op-code command the device to report its current operating status. It should be sent by the system controller after each set-up command string. There are no operands associated with this op-code.

4) RST - reset op-code

SYNTAX: RST DCS :CHnn

The RST command string resets the device at :CHnn to zero and opens the relays if used.

⁽¹⁾ For more details, refer to the TLD 488-16 OPERATOR'S MANUAL.

3-81 CIL TRANSMISSION FORMAT.

3-82 The sequence of commands which address a specific power supply at port 0, set its voltage to 10V, its current limit to 2A and its subsequent reset is illustrated below:

```
TRANSMISSION 1: FNC sp DCS sp :CH00 sp          (set-up)
                  SET sp VOLT sp 10 sp
                  SET sp CURL sp 2 cr lf
TRANSMISSION 2: STA cr lf                        (STATUS CHECK)
TRANSMISSION 3: RST sp DCS sp :CH00 cr lf      (shut-down)
```

NOTE 1: *sp = ASCII (space or blank), cr = ASCII (carriage return) lf = ASCII (line feed).*

NOTE 2: *The individual CIL statements of transmission 1 are shown on separate lines for readability only. In actuality they are concatenated into a single ASCII string.*

3-83 **THE CIRCUIT BREAKER CONTROL CIRCUIT (REFER TO FIG. 3-28).** The BOP is protected by the dual-coil CIRCUIT BREAKER/ON-OFF SWITCH (CB101). The current sensing coil of CB101 is connected in series with the primary winding of T201, thus detecting overcurrents reflected into the primary circuit and subsequently tripping the circuit breaker. The voltage sensing coil of CB101 is connected in series with an SCR (CR4) across the DRIVER COLLECTOR SUPPLY. If the SCR is triggered "on", the voltage sensing coil is energized and trips the circuit breaker. The SCR (CR4) can be triggered in several ways as described in paragraphs 3-83A thru 3-83D.

- A) On a-c line power loss or interruption, Q1 will lose its turn-on bias first, due to the small time-constant provided in its base circuit (not shown in simplified block diagram). As a result, Q2 is turned "on", energizing the diode in the optical isolator (LC-1) and providing a turn-on signal for the SCR (CR4).
- B) In the event of an excessive heat rise on the POWER STAGE ASS'Y (A4), the thermal switch (S401) will close, energizing the diode in the optical isolator (LC-1) and providing thus the turn-on signal for the SCR (CR4).
- C) In the event of an external, isolated turn-off signal (which, for example, in system applications, could originate from a companion BOP), the diode in the second optical isolator (LC-2) is energized. The resulting signal energizes in from the diode in the first optical isolator (LC-1) thus providing for SCR turn-on.
- D) A manual, non-isolated turn-off is provided which, when implemented with an external switch contact as shown in FIG. 3-28, will energize the diode in the first opto coupler (LC-1), thus providing the SCR turn-on.

3-84 If it is not desired to trip the circuit breaker (CB101) on a-c line power loss, it can be prevented by a jumper wire or an external switch across Pins 24 and 25 on PC-12. In this manner, Q1 is inhibited from providing a turn-on signal for Q2, thus avoiding triggering the SCR and tripping the circuit breaker.

3-85 **THE INDICATOR AND FLAG LOGIC CIRCUIT (SEE FIG. 3-29).** Digital Logic Circuits (IC15, IC16, IC17) are used in the BOP to drive the LED front panel lamps which indicate the prevailing operating mode:

E _o LIMIT MODE	(DS101)
I _o LIMIT MODE	(DS102)
E _o MODE	(DS103)
I _o MODE	(DS104)
REMOTE	(DS105)

Together with these visual front panel indicators, TTL-compatible status flags are provided at the rear programming connector (PC-12) for the above BOP operating modes. All status flags available on PC-12 indicate a logic "0" if the BOP is operating in the indicated operating mode, and a logic "1" if it is not.

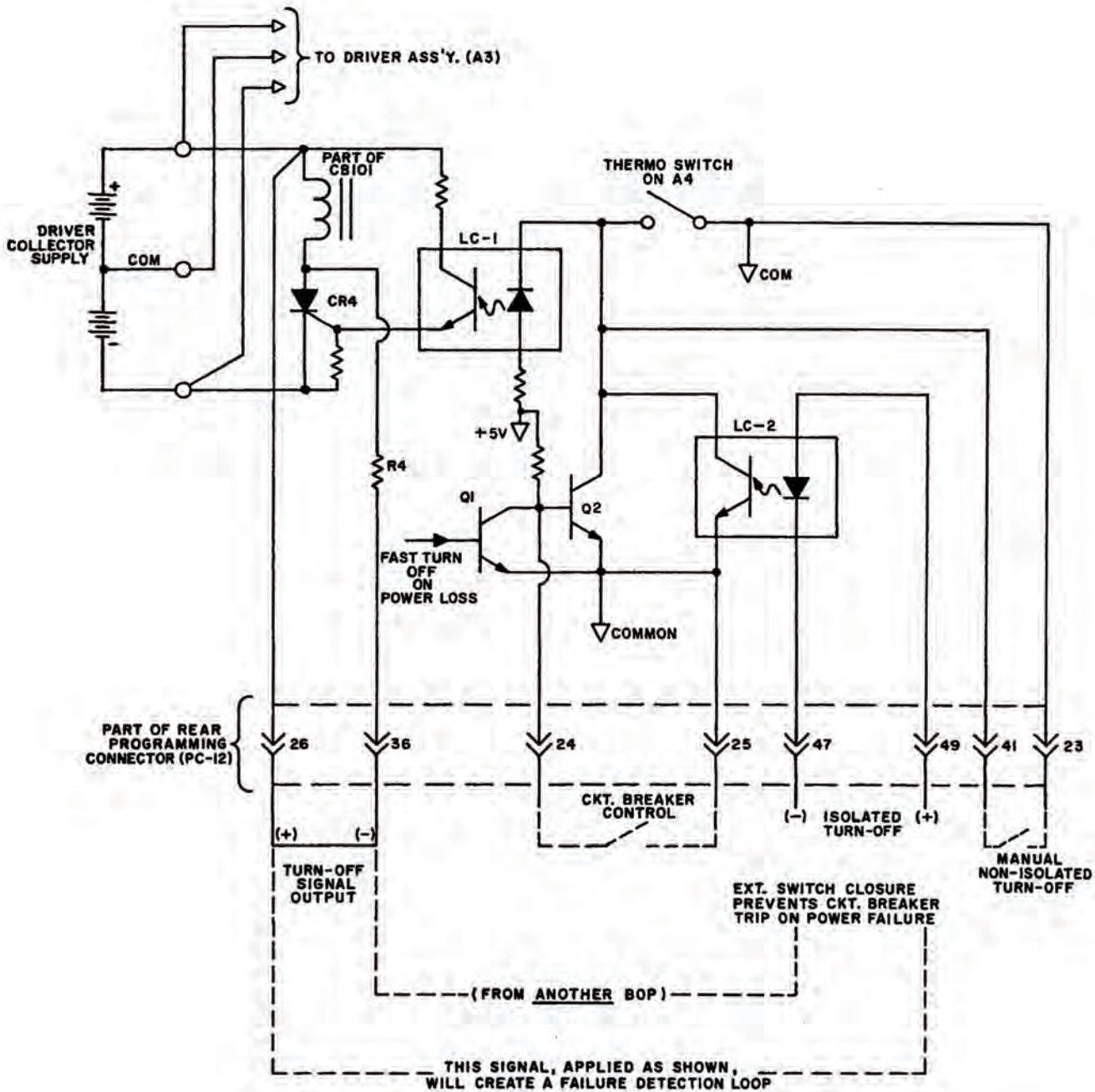

FIG. 3-28 CIRCUIT BREAKER CONTROL CIRCUIT, SIMPLIFIED DIAGRAM.

3-86 The logic status indicated in FIG. 3-29 are valid for the BOP operating in the voltage mode (E_0 MODE) and not driven by the GPIB INTERFACE. If the GPIB interface is connected, control of the BOP output may be assumed by the external controller, once the "REMOTE" command is applied via J204/P5 Pin 6. At this time, the REMOTE/LOCAL FLAG (PC-12 pin 35) will go to "0", the REMOTE front panel lamp goes on and the front panel MODE SWITCH (S103) is no longer functional. All other front panel LED indicators will function as in the local control mode.

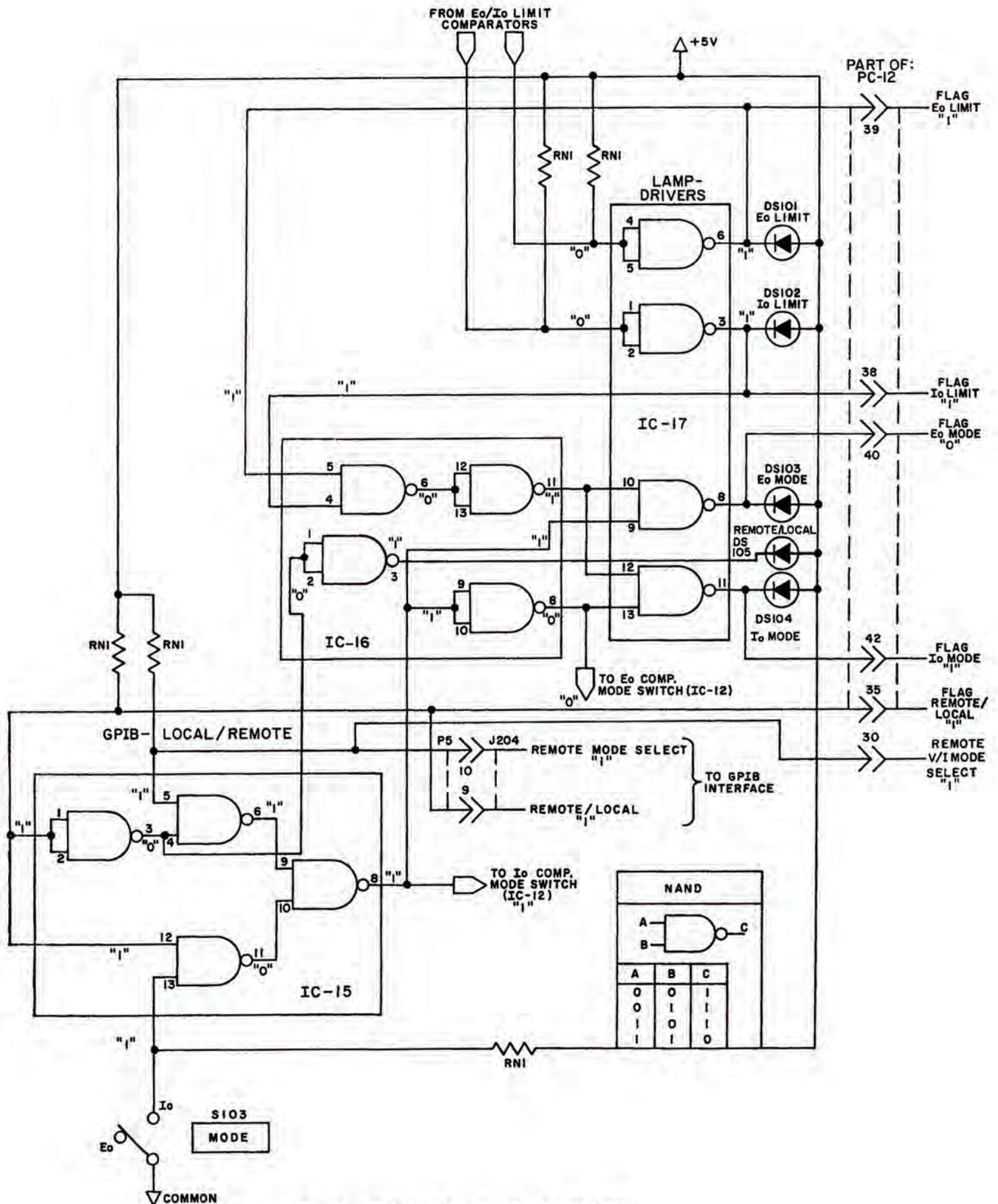

FIG. 3-29 INDICATOR LIGHT AND FLAG LOGIC. CONDITIONS SHOWN: Eo MODE, GPIB "LOCAL".

3-87 INTERNAL ADJUSTMENTS AND CALIBRATIONS

The location of all internal controls is illustrated in Section II, FIG. 2-1. The use of the zeroing controls for the BOP output voltage and current has been described in Section III. The adjustment for the remaining controls is described below. See FIG. 3-31 for disassembly.

Note: These controls are factory calibrated. Re-calibration is necessary only if components, related to the circuitry involving these controls have to be replaced.

- A) ADJUSTMENT OF THE (\pm) 10 VOLT CALIBRATION CONTROLS (R31,32)
 - 1) Connect a precision digital voltmeter to the REAR PROGRAMMING CONNECTOR (PC-12) from COMMON to pin 22 (- 10 volt) and subsequently to pin 28 (+ 10 volt).
 - 2) Turn the BOP "on" and locate the calibrating controls (see Section II, FIG. 2-1).
 - 3) Adjust control to exactly 10 volts as read out on the digital voltmeter.
- B) ADJUSTMENT OF THE AMMETER ZERO CONTROL (R50)
 - 1) Without a load connected to the BOP output, connect a digital voltmeter to the REAR PROGRAMMING CONNECTOR (PC-12) from COMMON to pin 10.
 - 2) Turn the BOP "on" and locate the AMMETER ZERO control (R50, see Section II, FIG. 2-1).
 - 3) Adjust control to exactly zero volts as read out on the digital voltmeter.
- C) ADJUSTMENT OF OPTOCOUPLER LINEARIZATION CONTROL (ONLY IN MODEL BOP 200-1M).
 - 1) Remove the BOP cover.
 - 2) Connect a resistive load to the output. Set load to produce the rated maximum output current.
 - 3) Attach an oscilloscope probe to test point, located on A1 control board (See Section III, FIG. 3-32). (Oscilloscope common should be connected to output common of the unit. Select 1V/Division or 2V/Division sensitivity on the oscilloscope.
 - 4) Set BOP to Voltage Mode with voltage control switch on "off" position (See Section II, FIG. 2-2).
 - 5) Using the Voltage Programming Input terminals, program the unit by using a triangular voltage source (Function Generator) producing a 20V p-p, 250 Hz triangular wave. Observe the output signal on the scope, and adjust R15A Linearization control (See Section II, FIG. 2-1) until the non-linearity in the ramps of the triangular wave disappears (See FIG. 3-30).

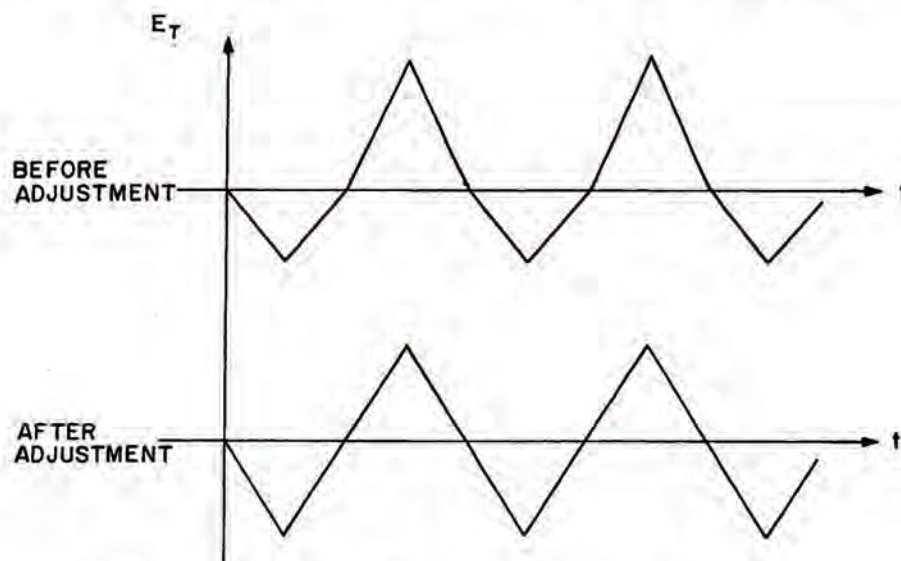
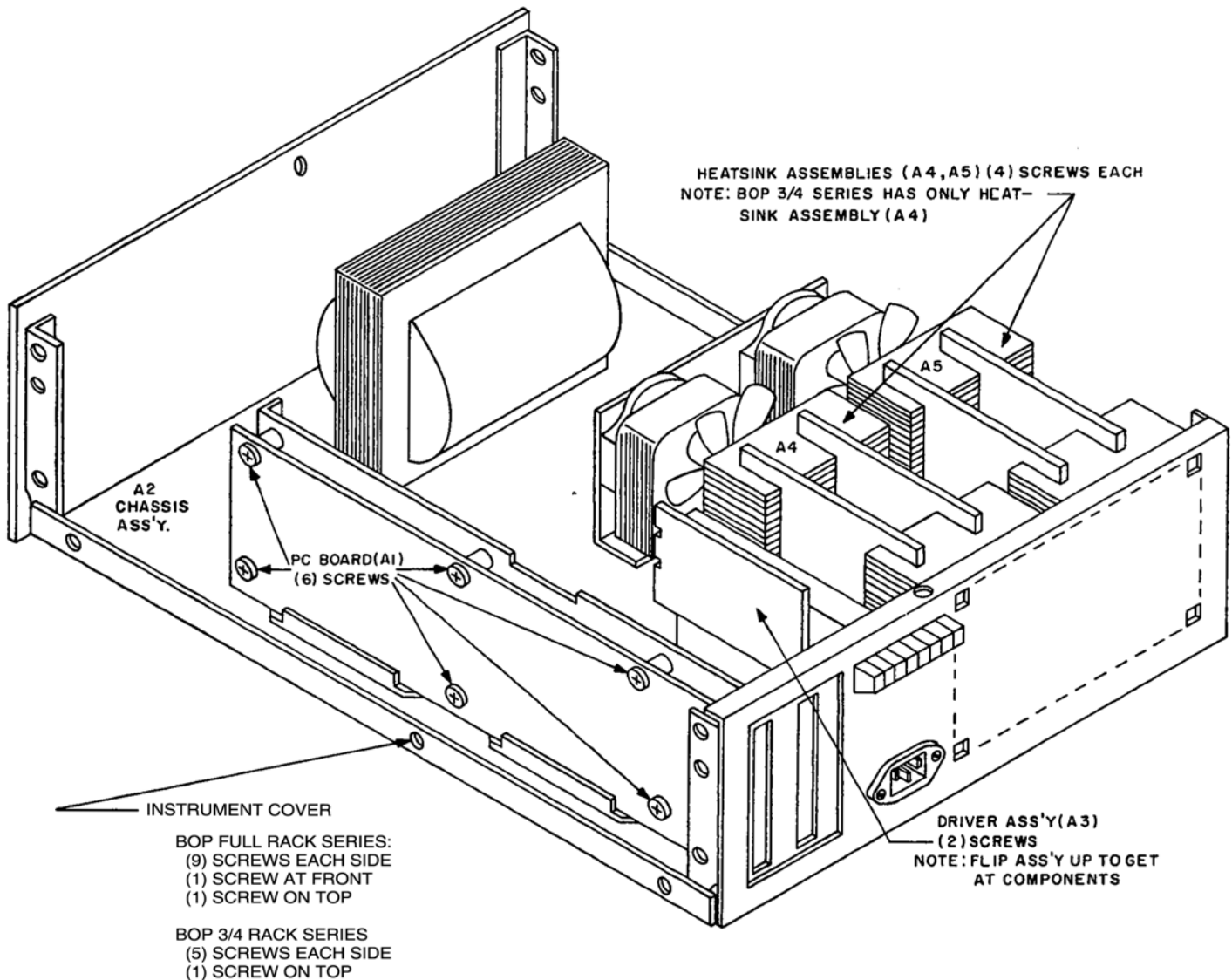

FIG. 3-30 OPTOCOUPLER LINEARIZATION IN MODEL BOP 200-1M.
(NOTE: THE TRIANGULAR WAVE DOES NOT HAVE TO SHOW ZERO VOLT D-C AVERAGE).

D) ADJUSTMENT OF THE I_O OUTPUT CURRENT (Applies only to Models specified in Table 2-1, Note 2.)

- 1) Remove the BOP cover.
- 2) Connect a precision ammeter in series with a temperature-compensated shunt resistor to the output of the power supply.
- 3) Set BOP MODE switch for current mode operation (see Fig. 2-2).
- 4) Set BOP voltage and current control switches to "OFF" position (see Fig. 2-2).
- 5) Using the CURRENT PROGRAMMING INPUT terminals, program the unit by using an accurate and precise DC voltage source. Set DC programming source to 10V (full scale output current.)
- 6) Turn BOP power supply "ON."
- 7) Adjust R316 (except on BOP 200-1M, adjust R314) (located on A3 assembly, see Figs. 3-31 and 3-33 for location) until current reading displayed on precision ammeter exactly matches the BOP rated output current (e.g. for a BOP 50-4M, adjust for exactly 4A.)



NOTE: BOP FULL-RACK MODEL SHOWN, FOR 3/4 RACK BOP MODELS, SEE SPECIAL REFERENCES IN DISASSEMBLY NOTES ON FIG. 3-31.

FIG 3-31 DISASSEMBLY, BOP SERIES.

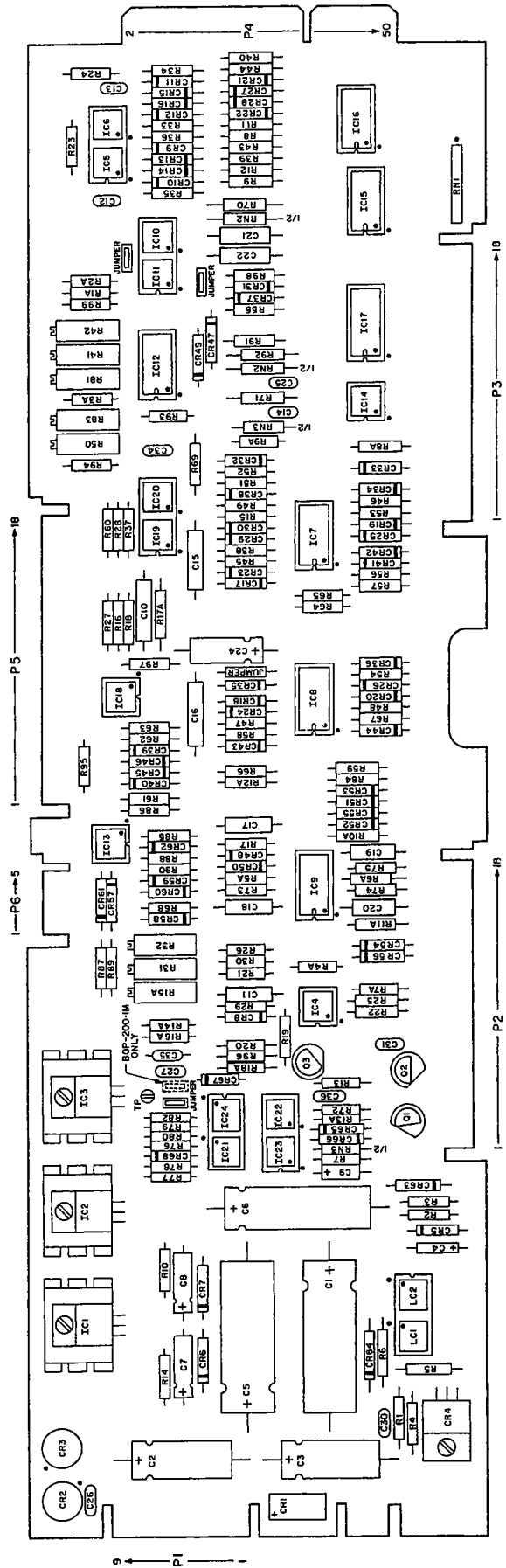

NOTE: NOT ALL COMPONENTS USED IN ALL MODELS.
SEE PARTS LIST.

FIG 3-32 COMPONENT LOCATION, CONTROL ASSEMBLY (A1).

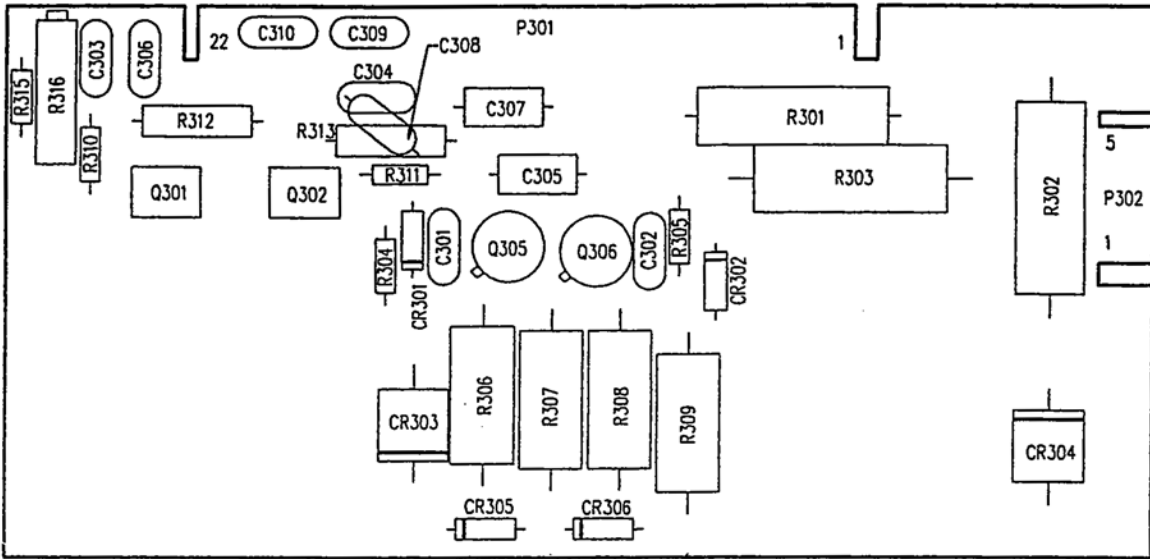

AM19469

NOTE: NOT ALL COMPONENTS USED IN ALL MODELS.

FIGURE 3-33 COMPONENT LOCATION, DRIVER ASS'Y (A3), ALL EXCEPT BOP 200-1M, BOP 200-1D

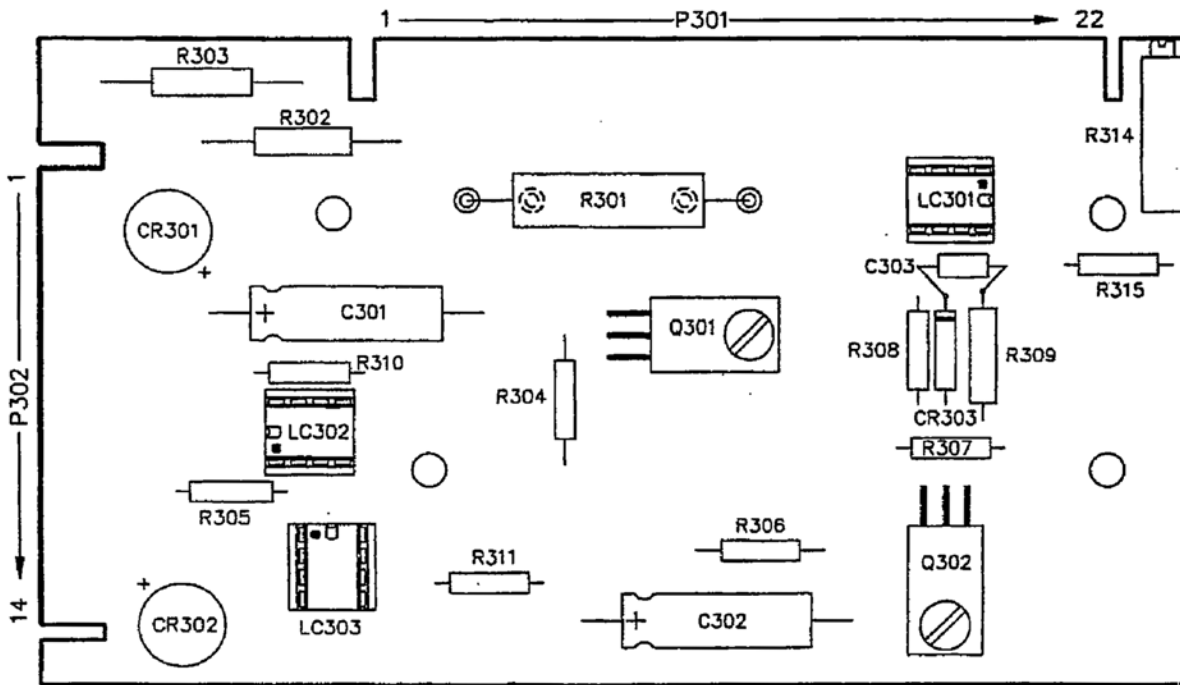

M19602

FIGURE 3-34 COMPONENT LOCATION, DRIVER ASS'Y (A3), BOP 200-1M, BOP 200-1D ONLY

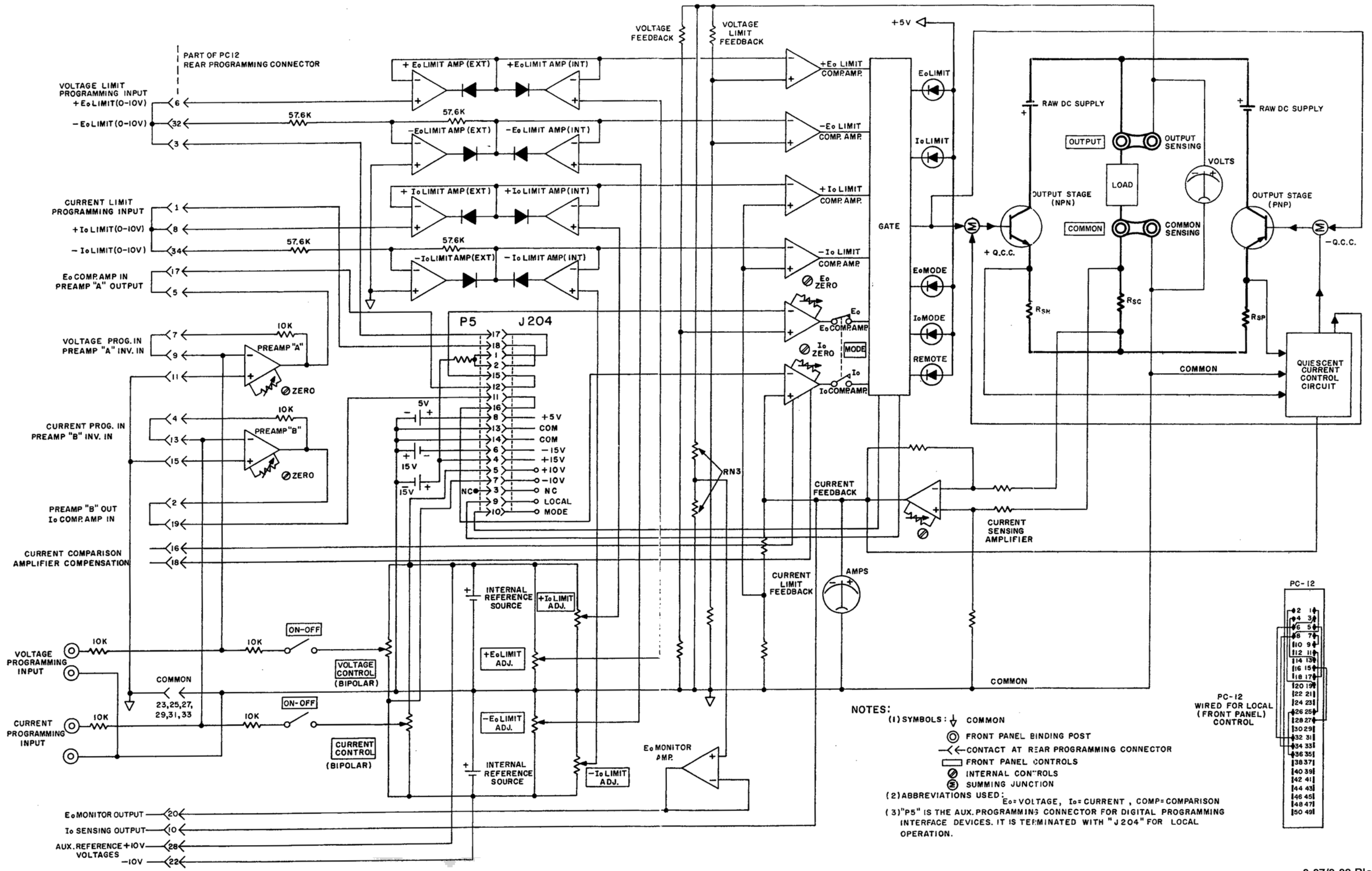

NOTES:

(1) SYMBOLS:
 ↓ COMMON
 ⊙ FRONT PANEL BINDING POST
 ← CONTACT AT REAR PROGRAMMING CONNECTOR
 □ FRONT PANEL CONTROLS
 ⊗ INTERNAL CONTROLS
 ⊕ SUMMING JUNCTION

(2) ABBREVIATIONS USED: E_o=VOLTAGE, I_o=CURRENT, COMP=COMPARISON

(3) "P5" IS THE AUX. PROGRAMMING CONNECTOR FOR DIGITAL PROGRAMMING INTERFACE DEVICES. IT IS TERMINATED WITH "J204" FOR LOCAL OPERATION.

PC-12 WIRING FOR LOCAL (FRONT PANEL) CONTROL

92	1
94	3
96	5
98	7
100	9
102	11
104	13
106	15
108	17
110	19
112	21
114	23
116	25
118	27
120	29
122	31
124	33
126	35
128	37
130	39
132	41
134	43
136	45
138	47
140	49

FIG. 3-35 SIMPLIFIED SCHEMATIC DIAGRAM, BOP SERIES.

